

Public Comment Period

There shall be a public comment period for each meeting with actionable items on the agenda, with the exception of teacher disciplinary hearings. Comments shall be limited to topics listed on the agenda and matters that are germane to the school board's jurisdiction.

The total public comment period shall be for no more than three (3) minutes. If an individual wishes to address the Board, he/she shall sign up on the form provided before the beginning of the board meeting to request time to speak. Each speaker shall be given no more than (3) minutes. Delegations must select only one individual to speak on their behalf unless otherwise determined by the Board.

Board Policy 1.609 Appeals to and Appearances Before the Board

WASHINGTON COUNTY BOARD OF EDUCATION

May 7, 2026

6:00 PM

Central Office

- I. Call to Order**
- II. Boones Creek Elementary Students**
- III. Daniel Boone High and David Crockett High Students - Teaching As A Profession**
- IV. Consideration of Meeting Agenda**
- V. Public Comment**
- VI. Approval of Meeting Minutes**
 - April 2, 2026**
 - April 8, 2026**
 - April 28, 2026**
- VII. Announcements**
 - A. May 4, 2026; 7:00 p.m.**
 - Daniel Boone High CTE Banquet**
 - Brinkley Center**
 - B. May 7, 2026; 9:00 a.m.**
 - County Commission Budget Committee**
 - C. May 8, 2026; 6:00 p.m.**
 - Asbury Graduation; Daniel Boone High School gymnasium**
 - D. May 11, 2026; 6:00 p.m.**
 - Teacher of the Year Banquet; Grace Meadows**
 - E. May 14, 2026; 7:00 p.m.**
 - David Crockett High CTE Banquet**
 - Carnegie Hotel Ballroom**

- F. **May 16, 2026**
 - David Crockett High Graduation; 9:00 a.m.**
 - Daniel Boone High Graduation; 1:00 p.m.**
 - ETSU Mini-Dome**
- G. **May 21, 2026**
 - Last Student Day (Abbreviated)**
- VIII. **Superintendent's Report**
 - A. **Student Board Member, Tyler Ball, David Crockett High School**
 - B. **Enrollment Report**
 - C. **Personnel Report**
 - D. **Maintenance Report**
 - E. **Grant Report**
 - F. **Monthly Financials**
 - G. **Day Field Trips**
 - H. **Other**
- IX. **Consideration of Consent Agenda**
 - A. **Approval of Purchase Orders**
 - 1. **Purchase Order 7378; SHI, Somerset, NJ; BusRight Suite License with Modules; Effective 5/1/26-6/30/26; Sourcewell Contract #121923-SHI;\$22,247.20; Line Item 72250388**
 - 2. **Purchase Order 7790; Benchmark Education Company LLC, New Rochelle,NY; Decodable Readers Theater Kits; District-wide; Grades 3-5 (10 ea); Funded by Tutoring Innovation Grant; \$10,486.00; Line Item 141E 71100 429 000 00000 011**
 - 3. **Purchase Order 7845; Trane Inc., Kingsport,TN; OMNIA Cooperative Pricing - Racine #3341; HVAC Units (2); \$37,508.00; Line Item 72620336**
 - 4. **Purchase Order 7862; Presentation Solutions; Buckner, KY; Banner Supplies; Grandview Elementary; BuyBoard Contract #76025; Funded by ISM Grant; \$17,954.60; Line Item 141E 71300 429 000 00000 002**
 - 5. **Purchase Order 7894; Advance Auto, Johnson City, TN; Propane Transfer 20x75 Evacuation System; Transportation Department; \$11,710.67; Line Item 72710453**
 - 6. **Purchase Order 7921; Benchmark Education Company, New Rochelle, NY; Rising Readers Club Teacher Set; Grade 1-3; Summer Programs; \$11,497.15; Funded by Summer School Grant**
 - 7. **Purchase Order 7922; Teacher Created Materials, Huntington Beach, CA; Take Home Literacy Backpacks for K-8; Summer Programs; \$29,337.19; Funded by Summer School Grant**
 - B. **Approval of Fee Waivers (Annual Agenda Item)**
 - Review Policy 6.709 Student Fees and Fines**
 - C. **Approval of SY26-67 Meal Prices (No Change)**
 - D. **Approval of Overnight Trip Requests**
 - 1. **David Crockett High School**
 - May 31st-June 6th, 2026**

Atlanta, GA
11th-12th Grade Electrical, Graphic Arts-Skills USA
Duration: 7 days

2. **David Crockett High School**
May 8th-9th, 2026
Hardin Valley, TN
TSSAA State Sectional Track Meet- Gr 9-12
Duration: 2 days
3. **David Crockett High School**
May 18th-23rd, 2026
Murfreesboro, TN
Baseball, Softball, and Soccer TSSAA State Tournaments
9-12 Grade Athletes
Duration: 6 days
4. **David Crockett High School**
June 5th-7th, 2026
High Point University, NC
9th-12th Grade Basketball Boys
Duration: 3 days
5. **Daniel Boone High School**
Dec 10-12th, 2026
Knightstown, Indiana-Hoosier Gym
Boys Basketball Team
Duration: 2 Days
6. **Daniel Boone High School**
June 1st-6th, 2026
Atlanta, GA
12th Grade Students National Skills USA Convention
Duration: 5 Days
7. **Daniel Boone High School**
June 2nd-3rd, 2026
Knoxville, TN
Girls Basketball Grades 9-12th
Duration: 2 Days
8. **Daniel Boone High School**
June 16th-21st, 2026
Indianapolis, Indiana
HOSA Competition Grades 10-12th
Duration: 6 days
9. **Daniel Boone High School**
June 11th-13th, 2026
Nashville, TN
Girls Basketball Grades 9th-12th
Duration: 3 Days

10. **Daniel Boone High School**
June 13th-16th, 2026
Orlando, FL
10-12th Grade Yearbook
Duration: 3 Days
 11. **Daniel Boone High School**
Dec. 26th-31st, 2026
Panama City, FL
Boys Basketball Team
Duration: 6 days
 12. **Daniel Boone High School**
June 5th-7th, 2026
Murfreesboro, TN MTSU
Basketball Camp
Duration: 3 days
- X. **Discussions/Presentations**
- A. **Approval to name the David Crockett High School gymnasium in memory of Hobart Powell**
 - B. **Five (5) Year Education Capital Projects Fund Plan FY27-FY31**
 - C. **Recommendation for 2025 TISA Outcome Base Funds**
 - D. **Approval of GEAR Up Grant and Stipends**
 - E. **Approval of Summer Learning Camp Grant FY26**
 - F. **Purchase Orders**
 1. **School Nutrition Requisition Number 1430260309; Gordon Food Service, Chicago, IL; Add On Gordons Non Food; \$90,000.00; Line Item 143E 73100-421**
 2. **School Nutrition Requisition Number 1430260310; Gordon Food Service, Chicago, IL; Add On Gordons Food; \$200,000.00; Line Item 143E 73100-422**
 3. **Purchase Order 7924; Benchmark Education, New Rochelle, NY; Steps to Advance Student Consumables & Digital; Materials for Summer Programs; \$43,173.42; Funded by Summer School Grant; Line Item determined when grant is finalized.**
 - G. **Approval of RFP for Beverage Provider**
 - H. **Awarding of bid for kitchen flooring at West View Elementary and Sulphur Springs Elementary; Line Item 143E 73100-710**
 - I. **Awarding of bid for intercoms at David Crockett High and West View Elementary; Line Item 141E 71100-708**
 - J. **Approval of Policies**
 1.
 - 1.804 Alcohol & Drugs in the Workplace**
 - 2.400 Revenues**
 - 4.302 Field Trips, Excursions, Competitions**
 - 5.1151 Telework During Emergencies**
 - 5.114 Personnel Records**
 - 5.200 Separation Practices for Tenured Teachers**

- 5.201 Separation Practices for Non-Tenured Teachers**
- 5.202 Separation Practices for Non-Certified Employees**
- 5.302 Sick Leave**
- 5.400 Personnel Health Examinations/Communicable Diseases**
- 5.403 Drug and Alcohol Testing for Employees**
- 5.606 Political Activities**
- 5.608 Tutoring for Pay**
- 5.800 Director of Schools**
- 6.411 Student Wellness**

K. Additional Overnight Trip

- 1. Sulphur Springs Elementary**
June 7-10th, 2026
Gatlinburg, TN
Varsity Dance Camp 6-8th Gr.
Duration: 4 Days

XI. Adjournment

WASHINGTON COUNTY BOARD OF EDUCATION

April 8, 2026; 4:00 PM; Central Office

Those present were Chairman Annette Buchanan, Vice-Chair David Hammond, Eric Barnes, Whitney Riddle, Mike Masters, Keith Ervin, Vince Walters, Chad Fleenor, Gregg Huddlestone, and Superintendent Jerry Boyd.

I. CALL TO ORDER

II. Public Comment

III. Discussion and possible action regarding Keith Ervin's comment.

Chad Fleenor made motion to censure Mr. Keith Ervin. Whitney Riddle seconded the motion which carried on roll call vote:

- Eric Barnes: *yes*
- Keith Ervin: *abstain (with conflict)*
- Chad Fleenor: *yes*
- David Hammond: *yes*
- Gregg Huddlestone: *yes*
- Mike Masters: *yes*
- Whitney Riddle: *yes*
- Vince Walters: *yes*
- Annette Buchanan: *yes*

IV. Convene to workshop for the FY27 Budget

V. FY27 Budget

The Board viewed a spreadsheet with the active budget next to a budget draft for FY27 that included Step Only with \$2,095.00 Teacher Increase to meet State 50k minimum salary Requirement. They also viewed options outlaying salary increases for certified, classified and and coaching supplement modifications. Also included was need for additional Special Educational Teachers. Following board suggestions, the Board will have a special called meeting for FY27 budget prior to the workshop on April 28th. The Board will look at a budget draft with a \$1.00 per raise for classified, 3% for system management, 25% coaching supplement.

VI. ADJOURNMENT

WASHINGTON COUNTY BOARD OF EDUCATION

April 2, 2026; 6:00 PM; Central Office

Those present were Chairman Annette Buchanan, Vice-Chair David Hammond, Eric Barnes, Whitney Riddle, Mike Masters, Keith Ervin, Vince Walters, Chad Fleenor, Gregg Huddleston, and Superintendent Jerry Boyd.

I. Call to Order

Mr. Fleenor led a prayer followed by the pledge to the flag, led by Hannah Campbell.

II. West View Elementary Students

The students had recently performed Willy Wonka and the Chocolate Factory. They gave a short presentation from the play.

III. Daniel Boone High Girls Basketball Team

III. Presentation from BrightRidge

BrightRidge presented a check for the school systems participation in their solar farm.

V. Recognition of Tenured Personnel

Personnel who were granted tenure status received a certificate of accomplishment.

VI. Consideration of Meeting Agenda

Chad Fleenor moved for approval of the meeting agenda, as amended, ad I. FY27 budget draft. Whitney Riddle seconded the motion which carried on roll call vote:

- Eric Barnes: *yes*
- Keith Ervin: *yes*
- Chad Fleenor: *yes*
- David Hammond: *yes*
- Gregg Huddleston: *yes*
- Mike Masters: *yes*
- Whitney Riddle: *yes*
- Vince Walters: *yes*
- Annette Buchanan: *yes*

VII. Public Comment

VIII. Approval of Meeting Minutes

A.

March 10, 2026

March 24, 2026

Gregg Huddleston moved for approval of the meeting minutes. Whitney Riddle seconded the motion which carried on roll call vote:

- Eric Barnes: *yes*
- Keith Ervin: *yes*
- Chad Fleenor: *yes*
- David Hammond: *yes*
- Gregg Huddleston: *yes*
- Mike Masters: *yes*
- Whitney Riddle: *yes*
- Vince Walters: *yes*
- Annette Buchanan: *yes*

IX. Announcements

A. April 2, 2026; 2:00 p.m.
County Commission HEW Committee

B. April 3, 2026
Good Friday
District Offices Closed/No School
April 4, 2026
Easter
April 5, 2026
Easter Monday
District Offices Closed/No School

C. April 8, 2026; 9:00 a.m.
County Budget Committee

D. April 14, 2026; 5:30 p.m.
Joint Meeting of the Board of Education and County Commission

E. April 27, 2026; 6:00 p.m.
County Commission Meeting

F. April 28, 2026; 6:00 p.m.
Monthly Board Workshop

G. April 30, 2026; 7:00 p.m.
Daniel Boone High and David Crockett High Top Ten % Banquet
Brinkley Center

H. May 4, 2026; 7:00 p.m.
CTE Banquet; Daniel Boone High and David Crockett High
Brinkley Center

I. May 8, 2026; 6:00 p.m.
Asbury Graduation
Daniel Boone High Gymnasium

J. May 11, 2026; 6:00 p.m.
Teacher of the Year Banquet
Grace Meadows Farm

K. May 16, 2026; Graduations; ETSU Mini-Dome
David Crockett High; 9:00 a.m.
Daniel Boone High; 1:00 p.m.

L. May 21, 2026
Last Student Day

X. Superintendent's Report

A. Student Board Member Hannah Campbell, David Crockett High School

B. Enrollment Report

C. Maintenance Report

D. Monthly Financials

E. Grant Report

F. Personnel Report

G. Day Trips

H. Other

XI. Consideration of Consent Agenda

David Hammond moved for approval of the consent agenda. Eric Barnes seconded the motion which carried on roll call vote:

- Eric Barnes: *yes*
- Keith Ervin: *yes*
- Chad Fleenor: *yes*
- David Hammond: *yes*
- Gregg Huddlestone: *yes*
- Mike Masters: *yes*
- Whitney Riddle: *yes*
- Vince Walters: *yes*
- Annette Buchanan: *yes*

A. Request for New Clubs

1. Ridgeview Elementary Dance Club

2. Boones Creek Elementary Dance Club

B. Purchase Orders

1. Dietary Requisition No 1430260255; Pepsi Cola Company; Add On Order for 2026; \$15,000.00; Line Item 143E 73100 422
2. Purchase Order 7648; College Board; Pre AP Courses; Daniel Boone High and David Crockett High; Not to exceed \$20,000.00; Line Item 141E 71100-449
3. Purchase Order 7548; B&H, New York, NY; Wacom Display Tablets (15); David Crockett High; CTE Digital Arts; Funded by ISM Grant; \$14,885.00 (\$959 ea); Line Item 141E 71300-730-000-00000-002
4. Purchase Order 7018; College Board; AP Exams for Daniel Boone High and David Crockett High; Price Modification from prior Board approval 12/4/25 for \$44,000); Not to exceed \$50,000.00; Line item 141E 72130-322
5. Purchase Order 7463; The Stage Depot, Ladera Ranch, CA; Stage System; Lamar Elementary; Funded by ISM Grant; \$24,999.00; Line Item 141E 71300 730 000 00000 002
6. Purchase Order 7577; Leonard Truck Outfitters, Johnson City, TN; Shelving Kits and Ladder Rack for 2 Vans (Installation Included); Maintenance Department; \$24,178.00; Line Item 141E 72710 729
7. Purchase Order 35917; Solution Tree, Bloomington, IN; Professional Development (3 Days); Jonesborough Elementary; \$21,300.00; Line Item 142E 722100 524 100

C. Request to Release Bids

1. Request to release bids for intercoms at West View Elementary and David Crockett High
2. RFP for Beverage Provider
3. Release Bids for Kitchen Floor Replacement at West View Elementary and Sulphur Springs Elementary

D. Request to Purchase 625 Chromebooks (\$288,543.75); 330 Access Points (\$211,092.75); Funded by County Educational Capital Fund

XII. Discussions/Presentations

A. Envelope Machine Request

Chad Fleenor moved for approval to purchase the envelope machine. David Hammond seconded the motion which carried on roll call vote:

- Eric Barnes: *yes*
- Keith Ervin: *yes*
- Chad Fleenor: *yes*
- David Hammond: *yes*
- Gregg Huddleston: *yes*

- Mike Masters: *yes*
- Whitney Riddle: *yes*
- Vince Walters: *yes*
- Annette Buchanan: *yes*

B. Trash Compactors for Daniel Boone High, David Crockett High, and Grandview Elementary

Chad Fleenor move for approval of the Trash Compactors for Daniel Boone High, David Crockett High, and Grandview Elementary. Vince Walters seconded the motion which carried on roll call vote:

- Eric Barnes: *yes*
- Keith Ervin: *yes*
- Chad Fleenor: *yes*
- David Hammond: *yes*
- Gregg Huddleston: *yes*
- Mike Masters: *yes*
- Whitney Riddle: *yes*
- Vince Walters: *yes*
- Annette Buchanan: *yes*

C. Purchase Orders

1. Purchase Order 29003; BSN Sports; Daniel Boone High; Middle School Football Uniforms; Not to Exceed \$11,000.00; Line Item 145L 620

Chad Fleenor Purchase Order 29003; BSN Sports; Daniel Boone High; Middle School Football Uniforms; Not to Exceed \$11,000.00; Line Item 145L 620. David Hammond seconded the motion which carried on roll call vote:

- Eric Barnes: *yes*
- Keith Ervin: *yes*
- Chad Fleenor: *yes*
- David Hammond: *yes*
- Gregg Huddleston: *yes*
- Mike Masters: *yes*
- Whitney Riddle: *yes*
- Vince Walters: *yes*
- Annette Buchanan: *yes*

2. Purchase Order 7718; Amitrace, Norcross, GA; VidPod Turnkey Video Podcast; Sole Source; Lamar Elementary; Funded by ISM Grant; \$15,990.00; Line Item 141E 71100 722 000 00000 002

Vince Walters Purchase Order 7718; Amitrace, Norcross, GA; VidPod Turnkey Video Podcast; Sole Source; Lamar Elementary; Funded by ISM Grant; \$15,990.00; Line Item 141E 71100 722 000 00000 002. Whitney Riddle seconded the motion which carried on roll call vote:

- Eric Barnes: *yes*
- Keith Ervin: *yes*
- Chad Fleenor: *yes*
- David Hammond: *yes*
- Gregg Huddlestone: *yes*
- Mike Masters: *yes*
- Whitney Riddle: *yes*
- Vince Walters: *yes*
- Annette Buchanan: *yes*

3. Purchase Order 7783; Gallopade Textbooks; TN 26-27 GAP Renewal Grades 3-4; \$56,336.09; Line Item 141E 71100-449

Chad Fleenor Purchase Order 7783; Gallopade Textbooks; TN 26-27 GAP Renewal Grades 3-4; \$56,336.09; Line Item 141E 71100-449;7782. Whitney Riddle seconded the motion which carried on roll call vote:

- Eric Barnes: *yes*
- Keith Ervin: *yes*
- Chad Fleenor: *yes*
- David Hammond: *yes*
- Gregg Huddlestone: *yes*
- Mike Masters: *yes*
- Whitney Riddle: *yes*
- Vince Walters: *yes*
- Annette Buchanan: *yes*

4. Purchase Order 7782; SAVAAS Learning Company, Paramus, NJ; Additional High School Biology Foundations Workbooks; \$33,288; Line Item 141E 71100 449

5. Purchase Order 7652; Presentation Solutions, Buckner, KY; BuyBoard Contract #76025; Color Pro Banner Maker Supplies; Lamar Elementary; \$19,058.61; Funded by ISM Grant; Line Item 141E 71300 429 000 00000 002

Chad Fleenor Purchase Order 7652; Presentation Solutions, Buckner, KY; BuyBoard Contract #76025; Color Pro Banner Maker Supplies; Lamar Elementary; \$19,058.61; Funded by ISM

Grant; Line Item 141E 71300 429 000 00000 002;7761;7720;7764;7754. Vince Walters seconded the motion which carried on roll call vote:

- Eric Barnes: *yes*
- Keith Ervin: *yes*
- Chad Fleenor: *yes*
- David Hammond: *yes*
- Gregg Huddlestone: *yes*
- Mike Masters: *yes*
- Whitney Riddle: *yes*
- Vince Walters: *yes*
- Annette Buchanan: *yes*

6. Purchase Order 7788; Benchmark Education; Renewal (3 yrs) SY 26-27,27-28,28-29; \$427,360.20; Line Item 141E 71100 449

7. Purchase Order 7785; Magma Math; Renewal (Year 2) SY27-28; \$76,720.00; Line Item 141E 71100 449

Chad Fleenor 7788;7785. Gregg Huddlestone seconded the motion which carried on roll call vote:

- Eric Barnes: *yes*
- Keith Ervin: *yes*
- Chad Fleenobr: *yes*
- David Hammond: *yes*
- Gregg Huddlestone: *yes*
- Mike Masters: *yes*
- Whitney Riddle: *yes*
- Vince Walters: *yes*
- Annette Buchanan: *yes*

8. Purchase Order 7784; Code HS Online Classroom; Computer Science; High Schools; 7/1/26-6/30/27; \$22,225.00; Line Item 141E 71100 449

Chad Fleenor Purchase Order 7784; Code HS Online Classroom; Computer Science; High Schools; 7/1/26-6/30/27; \$22,225.00; Line Item 141E 71100 449. Whitney Riddle seconded the motion which carried on roll call vote:

- Eric Barnes: *yes*
- Keith Ervin: *yes*
- Chad Fleenor: *yes*
- David Hammond: *yes*
- Gregg Huddlestone: *yes*
- Mike Masters: *yes*

- Whitney Riddle: *yes*
- Vince Walters: *yes*
- Annette Buchanan: *yes*

9. Purchase Order 7761: Applied Academic Labs, West Point, GA; Heat Press; Boones Creek Elementary; Funded by ISM Grant; \$14,686.00; Line Item 141E 71300 429 000 00000 002

10. Purchase Order 7720; Inspire Business Interiors, Johnson City, TN; David Crockett High School; Furniture for the Digital Arts Classroom; Funded by ISM Grant; \$42,571.59; Line Item 141E71100 722000 00000 002

11. Purchase Order 7764; Presentation Solutions; BuyBoard Contract 76025; Ridgeview Elementary; Poster Maker Supplies; Funded by ISM Grant; \$16, 999.46; Line Item 141E 71300 429 000 00000 002

D. Review of bids for kitchen equipment at Gray Elementary and South Central Elementary; Line Item 143E 73100-710

Chad Fleenor low bid from TriMark USA, LLLC, \$80,943.88. Vince Walters seconded the motion which carried on roll call vote:

- Eric Barnes: *yes*
- Keith Ervin: *yes*
- Chad Fleenor: *yes*
- David Hammond: *yes*
- Gregg Huddleston: *yes*
- Mike Masters: *yes*
- Whitney Riddle: *yes*
- Vince Walters: *yes*
- Annette Buchanan: *yes*

E. Discuss the process to develop a formal plan of action for potential PreK-5 and 6-8 schools reconfigurations.

Chad Fleenor move forward with the planning stages and gain input from stakeholders. Vince Walters seconded the motion which carried on roll call vote:

- Eric Barnes: *yes*
- Keith Ervin: *yes*
- Chad Fleenor: *yes*
- David Hammond: *yes*
- Gregg Huddleston: *yes*
- Mike Masters: *yes*
- Whitney Riddle: *yes*
- Vince Walters: *yes*

- Annette Buchanan: *yes*

F. Consideration of Board Resolution Opposing School Vouchers

Gregg Huddlestone Board Resolution Opposing School Vouchers. Vince Walters seconded the motion which carried on roll call vote:

- Eric Barnes: *yes*
- Keith Ervin: *yes*
- Chad Fleenor: *yes*
- David Hammond: *yes*
- Gregg Huddlestone: *yes*
- Mike Masters: *yes*
- Whitney Riddle: *yes*
- Vince Walters: *yes*
- Annette Buchanan: *yes*

G. Policy 1.609 Appeals to and Appearances Before the Board - 1st and 2nd Reading

Chad Fleenor Policy 1.609 Appeals to and Appearances Before the Board - waive 1st and pass on 2nd Reading. David Hammond seconded the motion which carried on roll call vote:

- Eric Barnes: *yes*
- Keith Ervin: *yes*
- Chad Fleenor: *yes*
- David Hammond: *yes*
- Gregg Huddlestone: *yes*
- Mike Masters: *yes*
- Whitney Riddle: *yes*
- Vince Walters: *yes*
- Annette Buchanan: *yes*

H. Overnight Trip Requests

Vince Walters overnight trips, as presented. Chad Fleenor seconded the motion which carried on roll call vote:

- Eric Barnes: *yes*
- Keith Ervin: *yes*
- Chad Fleenor: *yes*
- David Hammond: *yes*
- Gregg Huddlestone: *yes*
- Mike Masters: *yes*

- Whitney Riddle: *yes*
- Vince Walters: *yes*
- Annette Buchanan: *yes*

1. David Crockett High School

July 5th-10th, 2026

Washington, DC

FCCLA 9th-12th Grades

Duration: 5 Days

2. David Crockett High School

April 20th-23rd, 2026

Franklin, TN

Residential and Commercial Construction Gr.10-12th

Duration: 3 Days

XII. FY27 Budget

A meeting was set for 4:00 p.m. on April 8th for the FY27 General Purpose Budget.

XIII. Adjournment

WASHINGTON COUNTY BOARD OF EDUCATION

April 28, 2026; 6:00 PM; Central Office

Those present were Vice-Chair David Hammond, Eric Barnes, Whitney Riddle, Mike Masters, Vince Walters, Chad Fleenor, Gregg Huddlestone, and Superintendent Jerry Boyd. Chairman Annette Buchanan and Board member Keith Ervin were absent.

I. Call to Order for Called Meeting

II. Public Comment

No public comment.

III. FY27 Budget

Chad Fleenor moved to adopt the FY27 General Fund budget that includes a \$2,095.00 Teacher Increase to meet State 50k minimum salary Requirement, and increase of 3% to System Management Staff, \$1.00 Per Hour Increase Classified Staff, 25% Coaching Supplement Modification, with additional 3 Special Educational Teachers. The BOE requests \$3.885M in additional funding from the County Commission, this is in addition to increasing the Property Budget by \$250K and increasing the Sales Tax Revenue by \$1M. Vince Walters seconded the motion which carried on roll call vote:

- Annette Buchanan: *absent*
- Keith Ervin: *absent*
- Eric Barnes: *yes*
- Chad Fleenor: *yes*
- David Hammond: *yes*
- Gregg Huddlestone: *yes*
- Mike Masters: *yes*
- Whitney Riddle: *yes*
- Vince Walters: *yes*

IV. Adjourn and Convene to the Workshop

The Board reviewed the items below to be considered at the May 7th board meeting.

V. Academics

A. Personalized Learning through Edelements

Karen Norton, Daniel Boone High School

James White, David Crockett High School

The teachers shared their experience with Personalized Learning through Edelements.

B. Summer School Programs - Cindy Hayes

Ms. Hayes provided an overview of the programs that will be offered this summer.

VI. Business/Finance

A. Monthly Financials

The Board reviewed the monthly financials.

B. GEAR Up Grant

The Board reviewed the GEAR Up Grant as well as the stipends associated with the grants. The stipend is part of leadership in partnership with the GEAR Up program. The grant and stipends will be on the agenda for consideration.

C. Purchase Orders

1. Purchase Order 7378; SHI, Somerset, NJ; BusRight Suite License with Modules; Effective 5/1/26-6/30/26; Sourcewell Contract #121923-SHI;\$22,247.20; Line Item 72250388

2. Purchase Order 7790; Benchmark Education Company LLC, New Rochelle,NY; Decodable Readers Theater Kits; District-wide; Grades 3-5 (10 ea); Funded by Tutoring Innovation Grant; \$10,486.00; Line Item 141E 71100 429 000 00000 011

3. Purchase Order 7845; Trane Inc., Kingsport,TN; OMNIA Cooperative Pricing - Racine #3341; HVAC Units (2); \$37,508.00; Line Item 72620336

4. Purchase Order 7862; Presentation Solutions; Buckner, KY; Banner Supplies; Grandview Elementary; BuyBoard Contract #76025; Funded by ISM Grant; \$17,954.60; Line Item 141E 71300 429 000 00000 002

5. Purchase Order 7894; Advance Auto, Johnson City, TN; Propane Transfer 20x75 Evacuation System; Transportation Department; \$11,710.67; Line Item 72710453

6. Purchase Order 7921; Benchmark Education Company, New Rochelle, NY; Rising Readers Club Teacher Set; Grade 1-3; Summer Programs; \$11,497.15; Funded by Summer School Grant

7. Purchase Order 7922; Teacher Created Materials, Huntington Beach, CA; Take Home Literacy Backpacks for K-8; Summer Programs; \$29, 337.19; Funded by Summer School Grant

D. Approval of Fee Waivers (Annual Agenda Item)

Review Policy 6.709 Student Fees and Fines

VII. Recommendation for 2025 TISA Outcome Base Funds

The Board reviewed using the funds for purchasing classroom furniture for the high schools.

VIII. Operations

A. Request to name the David Crockett High School gymnasium in memory of Hobart Powell

The request will be on the May 7th agenda for approval.

B. SY 26-27 Meal Prices

Meal prices will remain the same for SY26-27.

C. Review quote to concrete bus garage and maintenance lots

D. Review of RFP for Beverage Provider

E. Review of bids for kitchen flooring at West View Elementary and Sulphur Springs Elementary; Line Item 143E 73100-710

F. Review of bids for intercoms at David Crockett High and West View Elementary; Line Item 141E 71100-708

G. Renovation of old Jonesborough Elementary School

The Board will continue discussions in September.

IX. Policy Updates

The following policies will be on the May 7th agenda for approval.

A.

1.804 Alcohol & Drugs in the Workplace

2.400 Revenues

4.302 Field Trips, Excursions, Competitions

5.1151 Telework During Emergencies

5.114 Personnel Records

5.200 Separation Practices for Tenured Teachers

5.201 Separation Practices for Non-Tenured Teachers

5.202 Separation Practices for Non-Certified Employees

5.302 Sick Leave

5.400 Personnel Health Examinations/Communicable Diseases

5.403 Drug and Alcohol Testing for Employees

5.606 Political Activities

5.608 Tutoring for Pay

5.800 Director of Schools

6.411 Student Wellness

X. Student Supports

XI. Superintendent

A. Overnight Trip Requests

1. David Crockett High School

May 31st-June 6th, 2026

Atlanta, GA

11th-12th Grade Electrical, Graphic Arts-Skills USA

Duration: 7 days

2. David Crockett High School

May 8th-9th, 2026

Hardin Valley, TN

TSSAA State Sectional Track Meet- Gr 9-12

Duration: 2 days

3. David Crockett High School

May 18th-23rd, 2026

Murfreesboro, TN

Baseball, Softball, and Soccer TSSAA State Tournaments

9-12 Grade Athletes

Duration: 6 days

4. David Crockett High School

June 5th-7th, 2026

High Point University, NC

9th-12th Grade Basketball Boys

Duration: 3 days

5. Daniel Boone High School

Dec 10-12th, 2026

Knightstown, Indiana-Hoosier Gym

Boys Basketball Team

Duration: 2 Days

6. Daniel Boone High School

June 1st-6th, 2026

Atlanta, GA

12th Grade Students National Skills USA Convention

Duration: 5 Days

7. Daniel Boone High School

June 2nd-3rd, 2026

Knoxville, TN

Girls Basketball Grades 9-12th

Duration: 2 Days

8. Daniel Boone High School

June 16th-21st, 2026

Indianapolis, Indiana

HOSA Competition Grades 10-12th

Duration: 6 days

9. Daniel Boone High School

June 11th-13th, 2026

Nashville, TN

Girls Basketball Grades 9th-12th

Duration: 3 Days

10. Daniel Boone High School

June 13th-16th, 2026

Orlando, FL

10-12th Grade Yearbook

Duration: 3 Days

11. Daniel Boone High School

Dec. 26th-31st, 2026

Panama City, FL

Boys Basketball Team

Duration: 6 days

12. Daniel Boone High School

June 5th-7th, 2026

Murfreesboro, TN MTSU

Basketball Camp

Duration: 3 days

XII. Adjournment

School	-2	-1	0	1	2	3	4	5	6	7	8	9	10	11	12	Total
Boones Creek Elementary School	17	16	85	84	110	84	93	79	102	77	78					825
Daniel Boone High School												279	270	270	223	1042
David Crockett High School												272	276	264	192	1004
Fall Branch Elementary School			20	17	32	19	22	35	26	24	21					216
Gray Elementary School	19		47	53	54	50	60	51	60	59	55					508
Grandview Elementary School	17	14	46	67	59	67	57	70	51	54	61					563
Jonesborough Elementary School	35	1	75	92	112	99	114	109	84	91	90					902
Lamar Elementary School	19		45	44	44	49	46	32	39	40	42					400
Ridgeview Elementary School	16		44	60	62	88	76	75	64	86	96					667
South Central Elementary School			14	11	20	15	22	26	17	11	16					152
Sulphur Springs Elementary School	16		33	37	35	34	44	34	51	38	44					366
University School			18	21	22	18	23	48	52	49	52	83	83	82	81	632
West View Elementary School			19	25	25	24	28	32	42	28	35					258
Tennessee Virtual Learning Academy												3	9	13	6	31
Washington County Special Ed Service School	3	21	3	3	1		2	1								34
Total	142	52	449	514	576	547	587	592	588	557	590	637	638	629	502	7600

Full District - <https://app.espace.cool/Woms/PublicAnalytic/Index?guid=dde5295c-df1a-474a-b823-4a8bd9b65d97>

Asbury - <https://app.espace.cool/Woms/PublicAnalytic/Index?guid=e61a4c0a-ed39-485a-befd-bc76b00a5b2b>

BCE - <https://app.espace.cool/Woms/PublicAnalytic/Index?guid=e9a185b1-26b1-409c-a97a-bf1bf13816ad>

DBHS - <https://app.espace.cool/Woms/PublicAnalytic/Index?guid=91dfdef2-bff7-43b4-a04e-16dc73a3500a>

DCHS - <https://app.espace.cool/Woms/PublicAnalytic/Index?guid=7cc09814-5753-44ee-bbea-8c233512630a>

CO - <https://app.espace.cool/Woms/PublicAnalytic/Index?guid=14237d1d-34fc-481f-a224-404f9f6d6a5c>

FBES - <https://app.espace.cool/Woms/PublicAnalytic/Index?guid=7bc55f59-47d1-4b33-a1fb-96a42b3e4968>

GVES - <https://app.espace.cool/Woms/PublicAnalytic/Index?guid=0b061f31-9847-4a14-afd8-35b2f25897bb>

GES - <https://app.espace.cool/Woms/PublicAnalytic/Index?guid=3567a5e2-e75a-41d2-af94-2871ce93f10a>

JES - <https://app.espace.cool/Woms/PublicAnalytic/Index?guid=e9233523-ef22-4440-a3ca-753bb4dad5d>

LES - <https://app.espace.cool/Woms/PublicAnalytic/Index?guid=3e2eb3b6-42f5-4932-aafc-596fc3581fa0>

Midway - <https://app.espace.cool/Woms/PublicAnalytic/Index?guid=557087e0-5f3e-4951-a538-efa094a7de7b>

RVES - <https://app.espace.cool/Woms/PublicAnalytic/Index?guid=e445ed82-298f-47fc-9f1c-12d68795ffd1>

SCES - <https://app.espace.cool/Woms/PublicAnalytic/Index?guid=19182fea-4f76-4570-8038-5ee9ec8aa93e>

SSES - <https://app.espace.cool/Woms/PublicAnalytic/Index?guid=be7abc19-2a4f-4d34-a9d9-5f3b7ac0dcd4>

WVES - <https://app.espace.cool/Woms/PublicAnalytic/Index?guid=c66a8c57-f4d8-47c3-a1f6-05c18bb47ccf>

Bus Garage - <https://app.espace.cool/Woms/PublicAnalytic/Index?guid=3f6c86d7-c52e-45fe-aff-4ffda625fd7>

Intent to Apply/Research	Grants Writer/Manager's Report	May 2026					
Tennessee Council for Career and Technical Education (TCCTE)	No announcement as of today. For Professional Development to a National Conference for Health Science Teachers in the district. Requesting \$11,656.94						
Toshiba America Foundation	No announcement as of today. DCHS Teacher submitted Toshiba grant for \$9,000 for a portable welding equipment.						
Project Diabetes forecasted	Would like WCG to reapply for Project Diabetes for pickleball courts.	This past grant cycle they did not award any school systems but only governments and nonprofits	Update: this grant will open back up in year 2028				
BJA FY 25 Student, Teachers, and Officers Preventing (STOP) School Violence Grant	This grant award has not been announced.						
USDA Equipment Grant	Forecasted to be available for school cafeteria equipment.						
Working with First Tennessee Development District and WCEDC	Continue the partnership process in implementing the logistics of the daycare and as a partner, following the guidelines of the grant award guidelines.						
Dollar General Foundation	This grant has been submitted. Summer Reading Grant for Book Bus Requesting \$3,000. Submitted and award announcement will be May 8, 2026.						
Dollar General Foundation	This grant has been submitted. Youth Literacy Grant is upto \$5,000. Will be working with Academic Specialist for RTI2 materials for districtwide support. Grant opens March 6, 2026. One other school was also working on this grant.						
Perkins V Reserve	Currently working on this grant application with CTE Director. Grant is upto \$50,000. Must focus on 4 pillars of the CTE program. Redirecting grant strategy, will be focusing on Advising and Industry Credentials.						
Google.org AI Ecosystems Application	Have not been notified of the award being announced. In collaboration between Operations and Academics grant was submitted for a 80% Google to 20% WCS match for a partnership with PlayLab. This partnership will provide training and software. Approximately a value of \$26,480 or more depending on finalized service agreement if awarded.						

National Education Association	No award announcement as of today. Lamar teacher is applying for the NEA Professional Development grant (\$2500) to receive Orton-Gillingham Training to support intervention program.
Lottery for Education Afterschool Program	In partnership with Coalition 4 Kids, they will be the lead applicant for our remaining schools to support afterschool programs. Coalition 4 Kids goal is to provide the afterschool programs throughout the school system.
Grants Awarded	
Governor's Early Literacy Program	Donation of 200 books for the Bookmobile.
Grants Managed	
VW grant middle and heavy duty vehicle	VW STATE GRANT is awarded. Washington County Schools is the fiscal agent for reimbursement requests for this state award. Grant award \$309,171.00 the balance would need to be funded by district funds. 1st quarterly report finished.
Ballad Health	\$1,000 award for David Crockett High School to provide Digital Printing equipment, supplies, and other materials to create promotional items in supporting Suicide Awareness Program. The equipment will make items such as T-Shirts and will create financial sustainability for future Suicide Awareness Programs.
TN Civics Grant (2 awards)	SSES and Gray Elementary Schools are applying for \$5,000 each to provide professional development, student educational experience, and foundation materials and other civics driven learning platforms. This grant will help in providing evidence in the application for the School Governor's Civics Seal. Both schools have been awarded in February, 2026. Students will be going on educational experiences to Andrew Jackson Museum and East Tennessee Historical Museum. They will receive classroom civic related materials and teachers will receive professional development with a scholar with detail discussion of the Declaration of Independent
TDOE Advancing Mental Health Pilot	Coordinated School Health was awarded \$5,000 to support Youth Mental Health First Aid Training for nurses and counselors. Participating Personnel will have training and will attend a conference.
United Way East TN Highlands	United Way of East Tennessee Highlands, sponsored a book drive for area book buses, we are one of 4 districts whose book bus is sponsored.

TN Tutoring Grant	Academic Department was awarded \$81,600 to provide tutoring support for students in K-8. They will be managing their award. This grant will pay stipends for tutors and other supporting supplies/materials. This grant is a bridge from our previous TN All Corps tutoring program. Same rules apply high-dosage small-ratio programming.				
Gear Up grant - ETSU	In partnership with ETSU Trio: working on contracts.	7 year grant: Goal is to start program in January, 2026. GEAR UP team includes Kelli Hauldren, Cindy Hayes, Twana McKinney, and Billy Stepp.	To provide 4 GEAR UP coordinators to work district-wide with 7th grade cohort through 1st year post-secondary.	A state-specific initiative that operates under the national Gaining Early Awareness and Readiness for Undergraduate Programs (GEAR UP) federal grant, which aims to increase the number of low-income students prepared for and succeeding in postsecondary education.	
ISM Grant	PLEASE NOTE: ISM funds has helped to support middle school CTE/STEM teachers and one high school CTE teacher. This grant ends in JUNE, 2026. Sustainability for the program to continue will start July 2026, if the School Board chooses to keep this positions. University School capital project will continue into next school year and will close their grant in 2027.			Help CTE Director update FY 26 ISM application and monthly payroll calculation and reimbursement requests	This year teachers are 25% match funded Note: schools involved in this grant were awarded (allocated FY2023) BCE \$500,000, DB \$1,000,000, DC \$1,000,000, FB \$200,000, GV \$500,000, Gray \$500,000, JES \$500,000, RV \$500,000, SC \$200,000, SS \$500,000, University \$1,000,000, WV \$500,000
TN Economic Community Development (ECD) Three Star Grant	PLEASE NOTE: these grants are only good for two (2) years from the start of the award. The funds must be used within the two year allocation of the award.	WCEDC was awarded \$250,000 for construction costs related to improvements for a childcare facility. Washington County Economic Development partnered with WCS to place a new community childcare facility. The partners do plan on having a play area for the children to play outside.		Still working on contract language agreement.	August 26, 2025
The public daycare center grants' MOUs are being drafted. The TVA Workforce Invest Grant has been awarded to the team for \$250,000. The Education Invest grant was awarded \$250,000.			WCS in partnership with Economic Development, City of Johnson City, and First Tennessee Development District.		
Public School Security Grant	Allocation:	\$162,221.01	Funding will support fencing, access controls, and barriers for walkways, signs and locking mechanisms for doors. Doors have been purchased and fencing has been bidded out and decided. Remaining funds are allocated and will be expended when the security equipment for school vestibule is installed.		
Lottery for Education Afterschool Program	\$75,000	Year 6 of the LEAPS program at South Central Elementary, I am program coordinator for the grant. This is the final year of this LEAPS grant cohort	In-Person monitoring was successful. Students who have met participation grant requirements will become photojournalists for one day at Bright Zoo.	Provide all necessary documentation into Department of Human Services Child Care Provider Portal to renew the SCES LEAPS site for continuing service	Help with any grant related to personnel, data reporting, purchases, and deliver orientation meetings, and attend meetings with the state department.
Comprehensive School Mental Health System pilot	The Comprehensive School Mental Health Implementation Pilot will equip participating districts and their respective schools with the tools and resources necessary to amplify existing mental health infrastructure.		The Comprehensive School Mental Health Implementation Pilot aims to strengthen and enhance mental health in schools by integrating systems, programs, and resources. Participating districts will receive personalized training, technical support, and resources that will enhance existing infrastructure to meet the needs of students, staff, and the school community.		
Book Bus	Assisting in the collaboration between the Book Bus and the Districtwide Family Resource Program. Initiating a pilot program by combining opportunities of receiving resources under the Family Resource Program and their partners (potential grants) and books by provided by grants and donations by using the Book Bus as a mobile hub throughout Washington County Communities.		Receive Books from Scholastic through GELF.		The Book bus will visit the school that will be hosting summer camp 9 times.

Revenue and Expense Summaries for March2026 for the 141, 142, & 143 Funds

141-Fund Revenues

- Revenue for March 2026 was \$9,065,962 compared to \$7,978,311 March 2025. This is an increase of \$1,087,649
 - The main key variations from last March are listed below.
 - 40110 Current Property Tax was an increase of \$360,835 which mostly due to timing of Trustee collections.
 - 40210 Local Options Sales Tax was an increase of \$121,442
 - 46510 TISA was an increase of \$186,990.00.
 - 46515 & 46980 was an increase of \$643,533 due to timing of state grant reimbursements.
 - 46596 was an increase of \$57,499 due to the timing of Paid Parental Leave reimbursement.
 - You can evaluate the Rural Option Sales Tax impact from the prior formula change to both the Washington County Schools and Johnson City Schools on document (4-A_Washington County Rural Option Sales Tax_March2026).

141-Fund Expenses

- Expenses for March 2026 are coming in at \$8,344,284.23. This is \$491,833.46 more than March 2025.
 - Major variances from March 2025
 - Overall salary and benefit expenses were \$169,987.33 more than March 2025.
 - 72610-328 for Janitorial Services were \$147,193.42 more than last March due to an invoice not being received in March 2025.
 - 76100-707 was \$44,500 more that March 2025 due to SSES Cafeteria improvements.
- You can also reference a report that gives some additional details this month on BOE Connected titled as (1-D_Summary_141_Payables Detail March2026).

142-Federal Fund

- The Federal Projects fund saw \$552,087 of flow through revenues in March 2026. The breakdown of the reimbursements are listed below.
- The current breakdown of revenue/reimbursements received are listed below:
 - Consolidated/Title Grants accounted for 54%
 - SPED grants accounted for 40%
 - All other grants accounted for 6%
- You can also reference a report that gives some additional details this month on BOE Connect titled as (2-A_Summary_142_Payables Detail March2026).

143-Dietary Fund (From the Trustee's Report-Unreconciled)

- Revenue for March 2026 came in at \$421,638 which is \$19K less than March 2025.
- Expenses came in around \$267K which is around \$154K less than March 2025.
- The unreconciled Dietary Fund balance for March 2026 off the Trustee's Revenue Report is just over \$1.706 Million.
 - Dietary experienced an increase of around \$154K in fund balance for March 2026 from the prior month.
 - In comparison to March 2025, the Dietary Fund balance has decreased by around \$53K, this is off the Trustee report which is an unreconciled report.
 - We will need to keep watch on this closely as we get close to the \$750K minimum fund balance threshold.

Account Level		2025-26	2024-25	2025-26	March	2024-25	2025-26	FYTD	2025-26	2025-26			
Fnd	Acct	Obj	Prj	Description	Revised Budget	March	March	Variance	FYTD Activit	FYTD Activit	Variance	Uncollected Reve	FY % Coll
141	40110	000	000	CURRENT PROPERTY TAX	13,552,792	1,040,130	1,400,965	360,835	13,621,243	13,840,049	218,806	-287,257	102.12
141	40120	000	000	TRUSTEE'S COLLECTIONS - PRIOR	98,228	23,314	66,404	43,090	80,829	322,997	242,169	-224,769	328.82
141	40125	000	000	CLK/MASTER COLLECTIONS-PRIOR	644	0	0	0	0	94	94	550	14.61
141	40130	000	000	CIRCUIT CLERK/CLERK & MASTER C	61,916	7,506	12,029	4,523	44,552	63,204	18,652	-1,288	102.08
141	40140	000	000	INTEREST AND PENALTY	61,707	13,082	19,615	6,533	44,971	69,686	24,715	-7,979	112.93
141	40162	000	000	PAYMENTS IN LIEU OF TAXES - LO	216,227	0	0	0	605	0	-605	216,227	0.00
141	40163	000	000	PAYMENTS IN LIEU OF TAXES - OT	25,410	31	3,384	3,353	14,385	6,751	-7,634	18,659	26.57
141	40210	000	000	LOCAL OPTION SALES TAX	21,000,000	1,638,744	1,760,186	121,442	16,757,185	17,450,501	693,315	3,549,499	83.10
141	40270	000	000	BUSINESS TAX	578,402	10,769	12,505	1,735	127,489	129,719	2,230	448,683	22.43
141	40275	000	000	MIXED DRINK TAX	3,542	2	0	-2	7,937	19	-7,918	3,523	0.54
141	40320	000	000	BANK EXCISE TAX	109,398	68,814	71,221	2,407	68,814	71,221	2,407	38,177	65.10
141	41110	000	000	MARRIAGE LICENSE	1,727	62	70	8	1,232	1,067	-165	660	61.78
141	43517	000	000	TUITION - OTHER	129,980	13,525	10,400	-3,125	105,165	98,050	-7,115	31,930	75.43
141	43581	000	000	COMMUNITY SERVICE FEES - CHILD	665,548	81,614	54,957	-26,657	529,656	447,684	-81,973	217,864	67.27
141	44120	000	000	RENT ON BUILDINGS	2,830	0	0	0	1,750	1,064	-686	1,766	37.60
141	44130	000	000	SALE OF MATERIALS AND SUPPLIES	1,914	291	0	-291	1,771	1,449	-322	465	75.68
141	44520	000	000	INSURANCE RECOVERY	74,207	0	0	0	0	0	0	74,207	0.00
141	44530	000	000	SALE OF EQUIPMENT	55,228	0	0	0	42,615	0	-42,615	55,228	0.00
141	44570	000	000	CONTRIBUTIONS & GIFTS	202,268	49,305	4,811	-44,494	251,241	47,646	-203,595	154,622	23.56
141	44990	000	000	OTHER LOCAL REVENUES - TAGS	393	72	-18,670	-18,742	341	319	-21	74	81.18
141	44991	000	000	OTHER LOCAL REVENUE	87,799	2,076	19,494	17,418	60,262	56,273	-3,989	31,526	64.09
141	44992	000	000	OTHER LOCAL REV- ROYALTIES/CO	33,608	5,041	2,283	-2,758	28,328	21,230	-7,098	12,378	63.17
141	45550	000	000	CLERK & MASTER	0	0	0	0	0	-10,812	-10,812	10,812	0.00
141	46510	000	000	TISA	51,611,398	4,899,384	5,086,374	186,990	39,943,608	41,464,994	1,521,386	10,146,404	80.34
141	46515	000	000	EARLY CHILDHOOD EDUCATION	247,352	39,232	247,352	208,119	199,201	277,535	78,334	-30,183	112.20
141	46515	000	000	ST SPED SPEC ED PRESCH REVENUE	133,260	0	38,967	38,967	0	38,967	38,967	94,293	29.24
141	46550	000	000	DRIVER EDUCATION	32,737	0	0	0	0	0	0	32,737	0.00
141	46590	000	000	OTHER STATE EDUCATION FUNDS	761,614	0	5,301	5,301	0	1,428,179	1,428,179	-666,565	187.52
141	46596	000	000	PAID PARENTAL LEAVE	0	0	57,499	57,499	0	58,319	58,319	-58,319	0.00
141	46610	000	000	CAREER LADDER PROGRAM	52,713	0	0	0	29,354	22,676	-6,678	30,037	43.02
141	46790	000	000	OTHER VOCATIONAL	2,864,979	0	45,556	45,556	996,898	520,560	-476,338	2,344,419	18.17
141	46851	000	000	STATE REVENUE SHARING - T.V.A.	1,353,820	0	0	0	668,572	747,577	79,005	606,243	55.22
141	46980	000	000	OTHER STATE GRANTS	935,951	14,086	149,500	135,414	173,672	251,457	77,785	684,494	26.87
141	47141	000	000	TITLE I GRANTS TO LOCAL EDUCAT	1,624	0	0	0	1,624	0	-1,624	1,624	0.00
141	47146	000	000	ENGLISH LANGUAGE AQU. GRANTS	8,093	0	0	0	0	0	0	8,093	0.00
141	47640	000	000	ROTC REIMBURSEMENT	181,443	0	15,159	15,159	114,724	129,224	14,500	52,219	71.22
141	48990	000	000	OTHER	1,756,448	71,231	600	-70,631	417,570	38,050	-379,520	1,718,398	2.17
141	49700	000	000	INSURANCE RECOVERY	17,821	0	0	0	17,821	45,170	27,348	-27,349	253.46
141	49800	000	000	OPERATING TRANSFERS	100,000	0	0	0	889,464	0	-889,464	100,000	0.00

Account Level		2025-26	2024-25	2025-26	March	2024-25	2025-26	FYTD	2025-26	2025-26			
<u>Fnd</u>	<u>Acct</u>	<u>Obj</u>	<u>Prj</u>	<u>Description</u>	<u>Revised Budget</u>	<u>March</u>	<u>March</u>	<u>Variance</u>	<u>FYTD Activit</u>	<u>FYTD Activit</u>	<u>Variance</u>	<u>Uncollected Reve</u>	<u>FY % Coll</u>
				Grand Revenue Totals	97,023,021	7,978,311	9,065,962	1,087,649	75,242,879	77,640,919	2,398,039	19,382,102	80.02

Number of Accounts: 39

***** End of report *****

	A	B	C	D	E	F	G	H	I	J	K	L	M	N
1	SALES TAX TRACKING													
2	141R 40210													
3														
4	YEAR	TOTAL	July	August	September	October	November	December	January	February	March	April	May	June
5														
6	1995-96	7,964,549.95	611,536.43	650,039.30	596,451.81	626,656.64	665,950.77	645,367.17	793,944.02	872,382.08	581,914.60	553,125.28	700,497.25	666,684.60
7	1996-97	8,336,657.30	668,621.91	695,781.06	645,426.90	665,996.66	712,853.08	700,269.94	714,674.24	917,676.40	636,923.88	635,082.70	639,073.10	704,277.43
8	1997-98	9,028,886.69	721,817.32	780,093.18	704,916.44	717,825.19	798,852.97	747,016.98	760,728.85	1,024,051.84	649,227.26	638,150.71	787,948.69	698,257.26
9	1998-99	9,418,336.41	729,516.21	780,343.86	758,281.99	769,388.96	789,685.47	793,285.27	808,672.84	1,049,009.40	669,997.81	685,164.29	785,149.89	799,840.42
10	1999-00	9,925,491.78	761,578.86	848,424.57	757,359.52	832,656.56	798,763.84	812,346.45	826,725.33	1,142,546.37	711,564.82	750,908.81	878,078.63	804,538.02
11	2000-01	10,302,344.61	804,204.89	905,337.72	804,216.35	854,382.25	909,453.32	794,725.07	882,257.31	1,178,919.01	758,048.36	742,368.32	860,763.60	807,668.41
12	2001-02	10,532,891.37	808,555.26	866,353.62	796,577.42	828,852.58	889,601.40	870,074.31	872,050.60	1,199,611.30	768,580.66	790,051.97	938,373.85	904,208.40
13	2002-03	10,638,027.23	906,277.17	974,296.94	882,472.09	811,952.60	891,857.89	850,620.49	926,239.19	1,186,561.52	763,464.89	727,893.01	896,976.99	819,414.45
14	2003-04	11,067,961.48	852,744.87	931,182.77	884,455.76	904,582.89	939,687.81	883,319.35	949,214.33	1,224,464.85	796,000.63	798,184.90	971,370.65	932,752.67
15	2004-05	12,141,242.02	959,427.54	1,003,502.83	961,878.30	960,187.49	981,448.59	962,577.75	1,007,923.70	1,354,489.51	869,026.19	1,061,329.31	1,043,956.65	975,494.16
16	2005-06	12,336,585.09	955,565.19	1,032,019.38	1,019,556.16	1,105,255.87	1,019,172.70	995,288.52	1,052,343.46	1,443,274.33	811,741.53	876,236.72	1,048,459.42	977,671.81
17	2006-07	12,847,409.98	1,026,100.62	1,085,657.40	1,035,122.60	1,044,487.23	1,102,319.02	1,016,987.55	980,057.85	1,443,529.82	1,018,080.51	955,096.95	1,130,190.78	1,009,779.65
18	2007-08	13,475,705.49	1,079,389.94	1,164,602.82	1,112,875.15	1,123,975.96	1,128,221.21	1,082,375.90	1,170,203.04	1,480,368.07	934,432.24	1,003,760.54	1,131,648.39	1,063,852.23
19	2008-09	13,118,209.41	1,121,283.53	1,163,968.03	1,069,948.56	1,109,937.70	1,119,035.49	1,083,890.72	1,091,466.64	1,441,865.04	858,933.82	992,382.26	1,070,456.28	995,041.34
20	2009-10	12,609,635.54	1,008,819.19	1,099,406.55	992,789.10	1,066,457.07	1,052,452.00	997,413.03	1,039,892.90	1,366,560.85	888,185.43	945,035.53	1,121,973.47	1,030,650.42
21	2010-11	13,050,988.91	1,054,228.59	1,128,189.89	1,037,584.63	1,056,839.88	1,086,389.24	1,054,070.16	1,094,354.84	1,429,909.64	867,910.25	1,009,209.95	1,143,124.29	1,089,177.55
22	2011-12	13,808,173.10	1,081,535.67	1,228,666.98	1,138,627.12	1,132,824.15	1,125,406.77	1,090,432.58	1,133,742.86	1,526,365.45	1,016,848.19	1,065,106.10	1,194,803.93	1,073,813.30
23	2012-13	13,530,626.40	1,137,511.17	1,176,802.38	1,071,451.21	1,148,396.78	1,150,162.91	1,096,243.83	1,142,826.70	1,516,667.47	785,969.43	1,037,806.81	1,169,086.53	1,097,701.18
24	2013-14	13,756,487.05	1,138,760.08	1,166,521.54	1,081,327.46	1,126,284.98	1,099,605.17	1,103,883.00	1,136,848.35	1,508,355.06	971,672.20	1,055,143.00	1,275,350.78	1,092,735.43
25	2014-15	14,057,315.44	1,142,752.51	1,227,623.79	1,131,340.43	1,189,344.14	1,190,743.05	1,134,318.63	1,199,396.63	1,588,182.32	889,370.36	1,008,340.90	1,211,709.73	1,144,192.95
26	2015-16	14,722,621.29	1,241,008.04	1,233,271.57	1,166,463.36	1,203,804.59	1,229,321.78	1,188,390.71	1,246,671.22	1,641,380.40	1,070,197.64	997,571.40	1,284,815.87	1,219,724.71
27	2016-17	14,747,100.82	1,183,242.43	1,271,727.15	1,176,910.43	1,236,255.66	1,252,584.64	1,203,060.65	1,234,360.41	1,672,699.50	977,436.65	1,033,968.30	1,288,153.30	1,216,701.70
28	2017-18	15,349,677.89	1,205,951.87	1,271,772.24	1,218,781.58	1,210,362.79	1,249,834.14	1,202,844.48	1,292,583.56	1,624,509.44	1,147,863.70	1,134,847.93	1,558,692.28	1,231,633.88
29	2018-19	15,494,923.37	1,278,018.86	1,291,098.17	1,228,129.70	1,291,319.95	1,284,627.33	1,285,032.84	1,328,654.02	1,591,314.78	1,249,696.22	1,156,902.45	1,353,122.68	1,157,006.37
30	2019-20	16,025,666.39	1,344,150.84	1,344,028.39	1,307,238.15	1,361,539.99	1,316,157.76	1,348,576.15	1,379,403.02	1,729,590.49	1,212,600.58	1,176,918.48	1,324,871.88	1,180,590.66
31	2020-21	18,656,288.63	1,395,726.34	1,499,518.71	1,411,794.82	1,382,621.85	1,465,357.10	1,472,356.92	1,510,857.41	1,869,107.00	1,464,509.00	1,610,321.46	1,840,466.32	1,733,651.70
32	2021-22	20,931,816.79	1,727,238.03	1,711,551.64	1,741,191.00	1,659,586.42	1,736,797.58	1,711,047.73	1,862,765.56	2,152,612.02	1,607,027.31	1,654,556.12	1,930,358.42	1,437,084.96
33	2022-23	22,857,494.37	1,898,693.27	1,921,027.35	1,828,958.80	1,803,789.27	1,926,053.40	\$ 1,878,522.95	1,931,396.64	2,269,090.00	1,801,473.36	1,668,098.37	1,966,856.01	1,963,534.95
34	2023-24	21,601,025.58	1,990,790.71	1,789,745.09	1,753,458.04	1,682,817.47	1,736,275.41	\$ 1,766,029.31	1,813,960.70	2,266,646.75	1,586,385.69	1,654,346.13	1,818,284.57	1,742,285.71
35	2024-25	22,244,594.11	1,824,507.00	1,833,757.00	1,830,075.87	1,824,105.97	1,769,380.11	\$ 1,954,793.00	1,897,212.04	2,184,610.00	1,638,744.00	1,634,652.00	1,942,460.00	1,910,297.12
36	2025-26	17,450,500.79	1,883,990.00	1,890,348.82	1,942,413.41	1,934,260.34	1,909,227.43	\$ 1,929,801.54	1,946,501.06	2,253,772.33	1,760,185.86			
37														
38		Prior Year-to-Date Comparison												
39	INC / (DEC)	693,315.80	59,483.00	56,591.82	112,337.54	110,154.37	139,847.32	(24,991.46)	49,289.02	69,162.33	121,441.86			
40														
41														
42														
43		Budgeted												
44														
45	% of FY26 Budget Collected		83.10%											
46	FY26 Budgeted Amount		21,000,000											
47														
48		TOTAL YTD %	July	August	September	October	November	December	January	February	March	April	May	June
49	2025-26	83.098%	8.971%	9.002%	9.250%	9.211%	9.092%	9.190%	9.269%	10.732%	8.382%			

EXPENSE NARRATIVE

MARCH, 2026

71100399 – OTHER CONTRACTED SERVICES

\$ 777,620.76 to ETSU University School ; January Revenue Sharing
22,727.28 for CSH School-Based Counselors

71100429 – 0009 – INSTRUCTIONAL SUPPLIES – JES – POOLED TISA FUNDS

\$ 4,000.00 for 500 Nearpod Instructional Suites

71100449 – TEXTBOOKS

\$ 2,636.40 to DCHS Graphics ; classroom materials printing

71100599 – 0008 – SCHOOL IMPROVEMENT FUNDS – GRAY

\$ 3,005.00 for miscellaneous in-school signage

71100722 – 002 – CTE ISM GRANT

\$ 2,742.97 for classroom equipment ; BCE
14,995.00 for classroom equipment ; Grandview
4,001.85 for classroom equipment ; Ridgeview

71300429 – 002 – CTE ISM GRANT SUPPLIES

\$ 2,935.98 for classroom supplies ; DBHS

71300471 – 002 – SOFTWARE – ISM GRANT

\$ 3,800.00 for classroom software ; Gray

71300730 – VOCATIONAL EQUIPMENT

\$ 6,210.77 for classroom equipment ; DBHS

71300730 – 002 – CTE ISM GRANT EQUIPMENT

\$ 7,774.89 for classroom equipment ; Ridgeview

5,245.05 for classroom equipment ; South Central

9,184.85 for classroom equipment ; Jonesborough Elementary

72120499 – OTHER SUPPLIES

\$ 8,264.80 for conference lodging

1,230.56 for conference expenses

72210524 – INSERVICE/STAFF DEVELOPMENT

\$ 1,424.32 for conference lodging

1,378.82 for conference expenses

2,750.00 for professional development fees

72220399 – OTHER CONTRACTED SERVICES

\$ 16,665.00 for Special Education OT/PT

72250350 – INTERNET CONNECTIVITY

\$ 5,139.00 for monthly access fee

72250399 – OTHER CONTRACTED SERVICES

\$ 8,211.03 for athletic tournaments management system annual renewal fee

72250499 – OTHER SUPPLIES

\$ 3,829.14 for six chromebooks and licenses ; system wide stock

4,679.75 for 20 Analog Radios ; system wide stock

6,723.56 for FSP Fusion Splicer ; system wide operations center

3,415.95 for outdoor security camera system ; Sulphur Springs

72310320 – DUES AND MEMBERSHIPS

\$ 8,271.00 to TSBA for Annual Membership

72610499 – OTHER SUPPLIES

\$ 5,599.30 for system wide ball field maintenance materials

72620335 – 0004 – BUILDING MAINTENANCE AND REPAIRS – BCE

\$ 7,335.00 for gymnasium floor maintenance

72620335 – 0007 – BUILDING MAINTENANCE AND REPAIRS – FALL BRANCH

\$ 4,116.00 for gymnasium floor maintenance

72620335 – 0013 – BUILDING MAINTENANCE AND REPAIRS – SULPHUR SPRINGS

\$ 20,260.40 for cafeteria flooring replacement

72620336 – 0007 – FALL BRANCH – MAINTENANCE & REPAIRS, EQUIPMENT

\$ 5,716.69 for gymnasium bleachers parts and repairs

72620499 – OTHER SUPPLIES

\$ 3,767.96 for electrical maintenance supplies

18,498.63 for HVAC maintenance supplies

17,687.27 for plumbing maintenance supplies

9,348.72 for grounds maintenance supplies

23,164.75 for general maintenance supplies

72620499 – 0013 – OTHER SUPPLIES – SULPHUR SPRINGS

\$ 21,417.91 for cafeteria tables and chairs

72620599 – OTHER CHARGES

\$ 9,113.31 for equipment rentals ; grounds department

72710330 – OPERATING LEASE PAYMENTS

\$ 2,981.09 for Ex-Mark mower leases

76100707 – BUILDING IMPROVEMENTS

\$ 44,500.00 for cafeteria tables and chairs ; Sulphur Springs

99100590 – TRANSFERS TO OTHER FUNDS

\$ 28,241.00 for EESI Loan Repayment # 46

		CHECK CHECK					
FND	ACCT	OBJ	PRJ	NUMBER	DATE	VENDOR	AMOUNT
141	72210	432	000	141236130	03/03/2026	BULK BOOK STORE	1,868.20
141	72320	399	000	141236131	03/03/2026	COMCAST	146.98
141	72320	399	000	141236131	03/03/2026	COMCAST	131.87
141	71100	499	000	141236132	03/03/2026	DCHS CHORAL MUSIC DE	2,000.00
141	72710	207	000	141236133	03/03/2026	DIRECT HEALTH CARE	400.00
141	72410	355	000	141236134	03/03/2026	KITE, JOSH	403.10
141	72510	355	000	141236135	03/03/2026	MASTERS, PAUL	33.35
141	72710	412	000	141236136	03/03/2026	MCPHERSON FLEETCARD	17,863.93 Diesel Fuel
141	72710	425	000	141236136	03/03/2026	MCPHERSON FLEETCARD	9,734.29 Gasoline
141	72320	355	000	141236137	03/03/2026	RIVERS, KIM	27.55
141	73300	599	000	141236138	03/03/2026	SEPANEK, NICOLE	66.00
141	71100	599	000	141236139	03/03/2026	SOLUTION TREE	2,384.00
141	71100	722	000	141236140	03/06/2026	AMAZON CAPITAL SERVI	2,742.97 BCE Classroom Equipment; CTE ISM
141	71100	722	000	141236140	03/06/2026	AMAZON CAPITAL SERVI	489.49
141	71300	429	000	141236140	03/06/2026	AMAZON CAPITAL SERVI	1,322.04
141	71300	429	000	141236140	03/06/2026	AMAZON CAPITAL SERVI	475.52
141	71300	429	000	141236140	03/06/2026	AMAZON CAPITAL SERVI	665.17
141	71300	429	000	141236140	03/06/2026	AMAZON CAPITAL SERVI	659.19
141	72210	432	000	141236140	03/06/2026	AMAZON CAPITAL SERVI	409.78
141	72210	432	000	141236140	03/06/2026	AMAZON CAPITAL SERVI	80.99
141	72210	432	000	141236140	03/06/2026	AMAZON CAPITAL SERVI	178.15
141	72210	432	000	141236140	03/06/2026	AMAZON CAPITAL SERVI	110.95
141	72210	432	000	141236140	03/06/2026	AMAZON CAPITAL SERVI	19.11
141	71100	429	000	141236140	03/06/2026	AMAZON CAPITAL SERVI	148.77
141	71100	429	000	141236140	03/06/2026	AMAZON CAPITAL SERVI	149.88
141	71100	429	000	141236140	03/06/2026	AMAZON CAPITAL SERVI	149.79
141	71100	429	000	141236140	03/06/2026	AMAZON CAPITAL SERVI	299.31
141	71100	429	000	141236140	03/06/2026	AMAZON CAPITAL SERVI	80.88
141	71100	429	000	141236140	03/06/2026	AMAZON CAPITAL SERVI	124.01
141	71100	429	000	141236140	03/06/2026	AMAZON CAPITAL SERVI	101.16
141	71100	429	000	141236140	03/06/2026	AMAZON CAPITAL SERVI	2,414.53
141	72130	499	000	141236140	03/06/2026	AMAZON CAPITAL SERVI	89.22
141	72130	499	000	141236140	03/06/2026	AMAZON CAPITAL SERVI	58.70
141	72130	499	000	141236140	03/06/2026	AMAZON CAPITAL SERVI	9.99
141	72130	499	000	141236140	03/06/2026	AMAZON CAPITAL SERVI	77.95
141	72120	599	000	141236140	03/06/2026	AMAZON CAPITAL SERVI	137.11
141	72120	599	000	141236140	03/06/2026	AMAZON CAPITAL SERVI	172.25
141	72120	599	000	141236140	03/06/2026	AMAZON CAPITAL SERVI	18.04
141	72710	424	000	141236140	03/06/2026	AMAZON CAPITAL SERVI	314.80
141	72710	453	000	141236140	03/06/2026	AMAZON CAPITAL SERVI	153.60
141	71200	429	000	141236140	03/06/2026	AMAZON CAPITAL SERVI	146.55
141	72620	499	000	141236141	03/06/2026	ANDY OXY CO INC	88.84
141	72710	424	000	141236142	03/06/2026	ATCO INTERNATIONAL	216.75
141	72510	355	000	141236143	03/06/2026	AYERS, TAMMY	40.60
141	72210	432	000	141236144	03/06/2026	BARNES & NOBLE INC	211.99
141	72120	355	000	141236145	03/06/2026	BEDERIAN, SHAWNA	132.68
141	72710	450	000	141236146	03/06/2026	BEST ONE TIRE	8,179.38 Tires for fleet vehicles
141	71100	499	000	141236147	03/06/2026	BIO RAD LABORATORIES	753.11
141	72510	355	000	141236148	03/06/2026	BLACK, CONNIE	45.68
141	72210	355	000	141236149	03/06/2026	BLANTON, SCOTT	357.43
141	72210	355	000	141236149	03/06/2026	BLANTON, SCOTT	309.58
141	72610	434	000	141236150	03/06/2026	BLOSSMAN GAS & APPLI	7,248.91
141	72610	434	000	141236150	03/06/2026	BLOSSMAN GAS & APPLI	1,984.88
141	72610	434	000	141236150	03/06/2026	BLOSSMAN GAS & APPLI	1,099.79
141	72710	442	000	141236150	03/06/2026	BLOSSMAN GAS & APPLI	7,722.79
141	72320	399	000	141236151	03/06/2026	BLUE RIDGE DOCUMENT	110.00

Propane

		CHECK CHECK					
FND	ACCT	OBJ	PRJ	NUMBER	DATE	VENDOR	AMOUNT
141	72710	453	000	141236152	03/06/2026	BRANHAM INDUSTRIAL L	47.76
141	72510	355	000	141236153	03/06/2026	BUXTON, MELISSA	104.40
141	72710	453	000	141236154	03/06/2026	CENTRAL STATES BUS S	1,086.96
141	72310	599	000	141236155	03/06/2026	CHAMBER OF COMMERCE	1,390.00
141	72510	355	000	141236156	03/06/2026	CHURCH, ANGELA	46.40
141	72620	499	000	141236157	03/06/2026	CLINE-HOLDER ELECTRI	2,210.46
141	72210	432	000	141236158	03/06/2026	COUGHLAN COMPANIES L	1,799.00
141	71100	499	000	141236159	03/06/2026	DANIEL BOONE HIGH SC	202.57
141	71100	499	000	141236160	03/06/2026	DAVID CROCKETT HIGH	108.52
141	72120	355	000	141236161	03/06/2026	DEBUSK, SYDNEE	287.83
141	72620	499	000	141236162	03/06/2026	DOWN TO EARTH	287.55
141	72620	499	000	141236162	03/06/2026	DOWN TO EARTH	63.00
141	72620	499	000	141236162	03/06/2026	DOWN TO EARTH	228.00
141	72620	499	000	141236162	03/06/2026	DOWN TO EARTH	273.00
141	72620	499	000	141236162	03/06/2026	DOWN TO EARTH	241.15
141	72620	499	000	141236162	03/06/2026	DOWN TO EARTH	379.50
141	72620	599	000	141236163	03/06/2026	EAST TENN RENT-ALLS	9,113.31
141	72620	499	000	141236164	03/06/2026	FENCO SUPPLY	46.20
141	72620	499	000	141236164	03/06/2026	FENCO SUPPLY	287.70
141	72620	499	000	141236164	03/06/2026	FENCO SUPPLY	110.53
141	72620	499	000	141236164	03/06/2026	FENCO SUPPLY	195.78
141	72620	499	000	141236164	03/06/2026	FENCO SUPPLY	25.97
141	72620	499	000	141236164	03/06/2026	FENCO SUPPLY	91.98
141	72620	499	000	141236164	03/06/2026	FENCO SUPPLY	552.81
141	72620	499	000	141236164	03/06/2026	FENCO SUPPLY	800.98
141	72620	499	000	141236164	03/06/2026	FENCO SUPPLY	454.31
141	72620	499	000	141236164	03/06/2026	FENCO SUPPLY	267.05
141	72620	499	000	141236164	03/06/2026	FENCO SUPPLY	149.28
141	72620	499	000	141236164	03/06/2026	FENCO SUPPLY	44.10
141	72610	399	000	141236166	03/06/2026	FLEENOR SECURITY SYS	39.99
141	72610	399	000	141236166	03/06/2026	FLEENOR SECURITY SYS	59.98
141	72610	399	000	141236166	03/06/2026	FLEENOR SECURITY SYS	84.99
141	72610	399	000	141236166	03/06/2026	FLEENOR SECURITY SYS	179.94
141	72610	399	000	141236166	03/06/2026	FLEENOR SECURITY SYS	84.99
141	72610	399	000	141236166	03/06/2026	FLEENOR SECURITY SYS	29.99
141	72610	399	000	141236166	03/06/2026	FLEENOR SECURITY SYS	25.00
141	72610	399	000	141236166	03/06/2026	FLEENOR SECURITY SYS	84.99
141	72610	399	000	141236166	03/06/2026	FLEENOR SECURITY SYS	37.01
141	72610	399	000	141236166	03/06/2026	FLEENOR SECURITY SYS	29.99
141	72610	399	000	141236166	03/06/2026	FLEENOR SECURITY SYS	222.50
141	72610	399	000	141236166	03/06/2026	FLEENOR SECURITY SYS	88.99
141	72210	432	000	141236167	03/06/2026	FOLLETT CONTENT SOLU	2,042.20
141	72210	432	000	141236167	03/06/2026	FOLLETT CONTENT SOLU	455.23
141	71100	599	000	141236168	03/06/2026	FOSTER SIGNS	3,005.00
141	72210	355	000	141236169	03/06/2026	FOUTCH, CHERIE	56.55
141	72810	599	000	141236170	03/06/2026	G & A SCREEN PRINTIN	498.20
141	72410	355	000	141236171	03/06/2026	GOOD, DANNY	488.65
141	72510	499	000	141236172	03/06/2026	GOVCONNECTION, INC	1,417.63
141	72110	355	000	141236173	03/06/2026	GRAY, SHANNON	121.08
141	72710	499	000	141236174	03/06/2026	GREENEVILLE OIL & PE	570.95
141	71300	429	000	141236175	03/06/2026	GRIMCO INC	110.07
141	72510	355	000	141236176	03/06/2026	HACKETT, BARBARA	76.13
141	72520	499	000	141236177	03/06/2026	IPROMOTEU	1,629.28
141	72620	499	000	141236178	03/06/2026	JD METALS	187.23
141	72510	355	000	141236179	03/06/2026	KILIAN, KIMBERLY	87.00
141	71300	429	000	141236180	03/06/2026	LAKESHORE LEARNING M	1,747.78

Equipment Rentals; Grounds

School Signs; Gray

		CHECK CHECK					
FND	ACCT	OBJ	PRJ	NUMBER	DATE	VENDOR	AMOUNT
141	72210	355	000	141236181	03/06/2026	LEWIS, TERESA	108.39
141	72610	599	000	141236182	03/06/2026	LYONS, KIM	52.20
141	72710	453	000	141236183	03/06/2026	MID-SOUTH BUS CENTER	1,616.87
141	71100	449	000	141236184	03/06/2026	MUSIC DOCTORS	692.53
141	71100	429	000	141236185	03/06/2026	ODP BUSINESS SOLUTIO	1,176.24
141	72710	425	000	141236186	03/06/2026	FARKER, TOD	65.00
141	71300	471	000	141236187	03/06/2026	PAXTON/PATTERSON	3,800.00
141	71300	429	000	141236188	03/06/2026	POCKET NURSE	52.98
141	71300	429	000	141236188	03/06/2026	POCKET NURSE	1,072.95
141	71100	429	000	141236189	03/06/2026	RENAISSANCE LEARNING	4,000.00
141	72210	355	000	141236190	03/06/2026	SAAM, SUSAN	3.77
141	72130	499	000	141236191	03/06/2026	SHOE CARNIVAL INC	69.98
141	72130	499	000	141236191	03/06/2026	SHOE CARNIVAL INC	761.87
141	72130	499	000	141236191	03/06/2026	SHOE CARNIVAL INC	129.96
141	72620	499	000	141236192	03/06/2026	SITE ONE LANDSCAPE S	4,931.17
141	72610	599	000	141236193	03/06/2026	SIX RIVERS MEDIA LLC	1,993.98
141	72710	599	000	141236193	03/06/2026	SIX RIVERS MEDIA LLC	946.00
141	71300	429	000	141236194	03/06/2026	SNAP-ON INDUSTRIAL	159.16
141	72610	399	000	141236195	03/06/2026	SOUTH EAST TN HAULIN	675.00
141	71300	499	000	141236196	03/06/2026	TCAT ELIZABETHTON	1,095.00
141	72610	599	000	141236197	03/06/2026	TENNESSEE B&E UNIT	450.00
141	72120	355	000	141236198	03/06/2026	TIPTON, CLANCI	87.00
141	72620	499	000	141236199	03/06/2026	TMS SOUTH	2,415.60
141	72610	454	000	141236200	03/06/2026	TOWN OF JONESBOROUGH	595.43
141	72610	454	000	141236200	03/06/2026	TOWN OF JONESBOROUGH	978.40
141	72610	454	000	141236200	03/06/2026	TOWN OF JONESBOROUGH	334.12
141	72610	454	000	141236200	03/06/2026	TOWN OF JONESBOROUGH	38.00
141	72610	454	000	141236200	03/06/2026	TOWN OF JONESBOROUGH	156.09
141	72610	454	000	141236200	03/06/2026	TOWN OF JONESBOROUGH	2,168.73
141	72620	499	000	141236201	03/06/2026	TRI CITY MOWER & SAW	507.41
141	72250	350	000	141236202	03/06/2026	UNITED DATA TECHNOLO	5,139.00
141	72320	307	000	141236203	03/06/2026	VERIZON WIRELESS	1,973.53
141	72250	499	000	141236203	03/06/2026	VERIZON WIRELESS	179.98
141	72610	399	000	141236204	03/06/2026	WATER SOLUTIONS ENGI	1,230.00
141	72610	410	000	141236205	03/06/2026	WEBB CHEMICAL & PAPE	19.44
141	72610	410	000	141236205	03/06/2026	WEBB CHEMICAL & PAPE	172.24
141	72610	410	000	141236205	03/06/2026	WEBB CHEMICAL & PAPE	86.24
141	72610	410	000	141236205	03/06/2026	WEBB CHEMICAL & PAPE	19.44
141	72610	410	000	141236205	03/06/2026	WEBB CHEMICAL & PAPE	251.02
141	72610	410	000	141236205	03/06/2026	WEBB CHEMICAL & PAPE	55.14
141	72610	410	000	141236205	03/06/2026	WEBB CHEMICAL & PAPE	427.51
141	72610	410	000	141236205	03/06/2026	WEBB CHEMICAL & PAPE	349.48
141	72610	410	000	141236205	03/06/2026	WEBB CHEMICAL & PAPE	1,911.60
141	72610	410	000	141236205	03/06/2026	WEBB CHEMICAL & PAPE	58.68
141	72610	410	000	141236205	03/06/2026	WEBB CHEMICAL & PAPE	172.30
141	72610	410	000	141236205	03/06/2026	WEBB CHEMICAL & PAPE	300.74
141	72610	410	000	141236205	03/06/2026	WEBB CHEMICAL & PAPE	1,487.11
141	72610	410	000	141236205	03/06/2026	WEBB CHEMICAL & PAPE	506.90
141	72610	410	000	141236205	03/06/2026	WEBB CHEMICAL & PAPE	257.10
141	72610	410	000	141236205	03/06/2026	WEBB CHEMICAL & PAPE	732.93
141	72210	355	000	141236207	03/06/2026	WOODS, BRANDON	47.13
141	72210	355	000	141236207	03/06/2026	WOODS, BRANDON	43.50
141	72210	355	000	141236207	03/06/2026	WOODS, BRANDON	145.00
141	72210	355	000	141236207	03/06/2026	WOODS, BRANDON	47.13
141	72210	355	000	141236207	03/06/2026	WOODS, BRANDON	138.33
141	72620	499	000	141236216	03/12/2026	ALUMINUM & GLASS SYS	45.88

Classroom Software; GRAY; CTE ISM

Nearpod Suites; JES TISA Pooled Funds

Grounds Maintenance Supplies

Internet Connectivity

		CHECK CHECK					
FND	ACCT	OBJ	PRJ	NUMBER	DATE	VENDOR	AMOUNT
141	72210	432	000	141236217	03/12/2026	AMAZON CAPITAL SERVI	127.27
141	72210	432	000	141236217	03/12/2026	AMAZON CAPITAL SERVI	21.99
141	72210	336	000	141236217	03/12/2026	AMAZON CAPITAL SERVI	1,477.12
141	71200	429	000	141236217	03/12/2026	AMAZON CAPITAL SERVI	181.90
141	71300	429	000	141236217	03/12/2026	AMAZON CAPITAL SERVI	32.16
141	72250	499	000	141236217	03/12/2026	AMAZON CAPITAL SERVI	412.10
141	72250	499	000	141236217	03/12/2026	AMAZON CAPITAL SERVI	211.84
141	72250	499	000	141236217	03/12/2026	AMAZON CAPITAL SERVI	43.98
141	71300	429	000	141236217	03/12/2026	AMAZON CAPITAL SERVI	1,500.57
141	71300	429	000	141236217	03/12/2026	AMAZON CAPITAL SERVI	98.28
141	71300	429	000	141236217	03/12/2026	AMAZON CAPITAL SERVI	1,581.73
141	71300	429	000	141236217	03/12/2026	AMAZON CAPITAL SERVI	788.65
141	71300	429	000	141236217	03/12/2026	AMAZON CAPITAL SERVI	1,753.92
141	71300	429	000	141236217	03/12/2026	AMAZON CAPITAL SERVI	807.38
141	71300	429	000	141236217	03/12/2026	AMAZON CAPITAL SERVI	1,835.65
141	71100	722	000	141236217	03/12/2026	AMAZON CAPITAL SERVI	2,036.97
141	71300	730	000	141236217	03/12/2026	AMAZON CAPITAL SERVI	695.00
141	71300	429	000	141236217	03/12/2026	AMAZON CAPITAL SERVI	501.94
141	71300	730	000	141236217	03/12/2026	AMAZON CAPITAL SERVI	788.99
141	71300	429	000	141236217	03/12/2026	AMAZON CAPITAL SERVI	383.63
141	71300	429	000	141236217	03/12/2026	AMAZON CAPITAL SERVI	589.27
141	71300	429	000	141236217	03/12/2026	AMAZON CAPITAL SERVI	549.80
141	71300	429	000	141236217	03/12/2026	AMAZON CAPITAL SERVI	908.39
141	71300	429	000	141236217	03/12/2026	AMAZON CAPITAL SERVI	980.35
141	71300	429	000	141236217	03/12/2026	AMAZON CAPITAL SERVI	983.22
141	71300	429	000	141236217	03/12/2026	AMAZON CAPITAL SERVI	19.15
141	71300	429	000	141236217	03/12/2026	AMAZON CAPITAL SERVI	1,326.44
141	71300	429	000	141236217	03/12/2026	AMAZON CAPITAL SERVI	379.97
141	71300	429	000	141236217	03/12/2026	AMAZON CAPITAL SERVI	1,009.72
141	72320	399	000	141236218	03/12/2026	AMERICAN BENEFIT ADM	200.00
141	72610	434	000	141236219	03/12/2026	ATMOS ENERGY	1,029.54
141	72610	434	000	141236219	03/12/2026	ATMOS ENERGY	701.66
141	72610	434	000	141236219	03/12/2026	ATMOS ENERGY	338.91
141	72610	434	000	141236219	03/12/2026	ATMOS ENERGY	1,179.47
141	72610	434	000	141236219	03/12/2026	ATMOS ENERGY	871.56
141	72610	434	000	141236219	03/12/2026	ATMOS ENERGY	5,780.27
141	72610	434	000	141236219	03/12/2026	ATMOS ENERGY	4,637.79
141	72120	499	000	141236220	03/12/2026	BANK CARD	8,264.80
141	72210	355	000	141236220	03/12/2026	BANK CARD	3,305.92
141	72130	524	000	141236220	03/12/2026	BANK CARD	1,520.10
141	72210	524	000	141236221	03/12/2026	BANKCARD	1,175.00
141	72710	599	000	141236221	03/12/2026	BANKCARD	410.00
141	72250	399	000	141236221	03/12/2026	BANKCARD	822.00
141	72520	355	000	141236221	03/12/2026	BANKCARD	725.15
141	72220	355	000	141236222	03/12/2026	BOWMAN, JEREMY	125.43
141	72320	307	000	141236223	03/12/2026	BRIGHTSPEED	27.99
141	71100	399	000	141236224	03/12/2026	CADAS INC	882.00
141	72210	355	000	141236225	03/12/2026	CALDERWOOD, TAMARA	89.18
141	72610	454	000	141236227	03/12/2026	CHUCKEY UTILITY DIST	356.82
141	72620	499	000	141236228	03/12/2026	CITY ELECTRIC SUPPLY	1,557.50
141	72610	454	000	141236229	03/12/2026	CITY OF KINGSPORT	327.62
141	72210	355	000	141236230	03/12/2026	COLLETTE, AMY	347.62
141	72230	355	000	141236231	03/12/2026	DBHS FFA	1,576.00
141	72710	599	000	141236232	03/12/2026	DIRECT HEALTH CARE	1,167.50
141	72620	499	000	141236233	03/12/2026	ELECTRO-MECH	766.00
141	72620	499	000	141236234	03/12/2026	FARRELL CALHOUN INC	534.21

Natural Gas
Conference Lodging
Conference Lodging

CHECK CHECK							
FND	ACCT	OBJ	PRJ	NUMBER	DATE	VENDOR	AMOUNT
141	72620	499	000	141236235	03/12/2026	FERGUSON ENTERPRISES	6,806.80 Plumbing mtnce Materials
141	72120	599	000	141236237	03/12/2026	FOOD CITY	283.14
141	72210	524	000	141236237	03/12/2026	FOOD CITY	190.35
141	72310	599	000	141236237	03/12/2026	FOOD CITY	176.41
141	71100	399	000	141236238	03/12/2026	FRONTIER HEALTH	22,727.28 CSH Counselors
141	72710	412	000	141236239	03/12/2026	GOOD, ETHAN	126.67
141	72220	399	000	141236240	03/12/2026	GRACE REHABILITATION	16,665.00 Sped OT/PT
141	72620	499	000	141236241	03/12/2026	GRAY STATION HARDWAR	263.73
141	72620	499	000	141236242	03/12/2026	HEELY-BROWN COMPANY	3,277.50 Mtnce Dept Roofing Materials
141	72210	355	000	141236243	03/12/2026	HOLLEY, PRESTON	229.10
141	72120	355	000	141236247	03/12/2026	JACKSON, KRISTEN	94.25
141	72220	355	000	141236248	03/12/2026	JOHNSON, AMY	73.23
141	72610	454	000	141236249	03/12/2026	JOHNSON CITY UTILITY	1,372.39
141	72610	454	000	141236249	03/12/2026	JOHNSON CITY UTILITY	10.54
141	71100	399	000	141236250	03/12/2026	LANGUAGE TRAINING CE	81.18
141	72210	355	000	141236251	03/12/2026	LEONARD, JILL	82.65
141	72620	499	000	141236252	03/12/2026	LOWE'S	7,443.11 Mtnce Dept Materials
141	71300	429	000	141236252	03/12/2026	LOWE'S	745.29
141	71300	429	000	141236252	03/12/2026	LOWE'S	1,817.97
141	72220	355	000	141236253	03/12/2026	LYONS, REBECCA	63.80
141	72220	355	000	141236254	03/12/2026	MARSHALL, EMILY	154.43
141	72620	499	000	141236255	03/12/2026	MEADE TRACTOR	377.62
141	72210	524	000	141236256	03/12/2026	NIET	2,750.00 Professional Development Res
141	72250	499	000	141236257	03/12/2026	ODP BUSINESS SOLUTIO	88.07
141	72250	499	000	141236257	03/12/2026	ODP BUSINESS SOLUTIO	715.64
141	72250	499	000	141236257	03/12/2026	ODP BUSINESS SOLUTIO	649.60
141	72250	499	000	141236257	03/12/2026	ODP BUSINESS SOLUTIO	273.82
141	72250	499	000	141236257	03/12/2026	ODP BUSINESS SOLUTIO	199.75
141	72250	499	000	141236257	03/12/2026	ODP BUSINESS SOLUTIO	528.88
141	72250	499	000	141236257	03/12/2026	ODP BUSINESS SOLUTIO	176.14
141	72210	355	000	141236258	03/12/2026	OGLE, JOSH	247.95
141	71100	299	000	141236259	03/12/2026	OMNI GROUP	250.00
141	72610	399	000	141236260	03/12/2026	PREMIER FIRE PROTECT	975.00
141	72250	499	000	141236261	03/12/2026	QUILL LLC	129.59
141	72320	435	000	141236261	03/12/2026	QUILL LLC	534.51
141	72320	435	000	141236261	03/12/2026	QUILL LLC	18.23
141	72320	435	000	141236261	03/12/2026	QUILL LLC	113.21
141	72120	399	000	141236262	03/12/2026	R.H.A.T. INC	175.00
141	72220	355	000	141236263	03/12/2026	REID, JANEY	50.75
141	71100	299	000	141236264	03/12/2026	RIDLEN, ANNA	135.00
141	72320	399	000	141236265	03/12/2026	ROBERT J. YOUNG COMP	1,499.25
141	72120	355	000	141236266	03/12/2026	SALYER, WENDI	337.70
141	72220	355	000	141236267	03/12/2026	SELF, LEA	218.59
141	72250	499	000	141236268	03/12/2026	SHIELDS ELECTRONICS	4,679.75 20 Radios; Tech Dept
141	71300	429	000	141236269	03/12/2026	SNAP-ON INDUSTRIAL	159.16
141	72220	355	000	141236270	03/12/2026	ST JOHN, SEBRENA	85.55
141	72320	435	000	141236272	03/12/2026	TENNESSEE OFFICE SUP	230.86
141	72620	499	000	141236273	03/12/2026	TMS SOUTH	414.02
141	72620	499	000	141236273	03/12/2026	TMS SOUTH	372.90
141	72220	355	000	141236274	03/12/2026	TRAINOR, THEVA	50.03
141	72620	499	000	141236275	03/12/2026	TRANE COMPANY	11,997.00 HVAC Mtnce Materials
141	72710	453	000	141236276	03/12/2026	TRUCK PRO	1,161.18
141	72320	307	000	141236277	03/12/2026	UNITED DATA TECHNOLO	147.86
141	72320	307	000	141236277	03/12/2026	UNITED DATA TECHNOLO	238.25
141	72320	307	000	141236277	03/12/2026	UNITED DATA TECHNOLO	347.13
141	72320	307	000	141236277	03/12/2026	UNITED DATA TECHNOLO	315.96

		CHECK CHECK							
FND	ACCT	OBJ	PRJ	NUMBER	DATE	VENDOR		AMOUNT	
141	72320	307	000	141236277	03/12/2026	UNITED DATA TECHNOLO		130.54	
141	72320	307	000	141236277	03/12/2026	UNITED DATA TECHNOLO		204.08	
141	72320	307	000	141236277	03/12/2026	UNITED DATA TECHNOLO		161.49	
141	72320	307	000	141236277	03/12/2026	UNITED DATA TECHNOLO		26.85	
141	72320	307	000	141236277	03/12/2026	UNITED DATA TECHNOLO		151.18	
141	72320	307	000	141236277	03/12/2026	UNITED DATA TECHNOLO		233.84	
141	72320	307	000	141236277	03/12/2026	UNITED DATA TECHNOLO		517.10	
141	72320	307	000	141236277	03/12/2026	UNITED DATA TECHNOLO		242.96	
141	72320	307	000	141236277	03/12/2026	UNITED DATA TECHNOLO		130.85	
141	72320	307	000	141236277	03/12/2026	UNITED DATA TECHNOLO		151.08	
141	72710	307	000	141236277	03/12/2026	UNITED DATA TECHNOLO		19.14	
141	72620	307	000	141236277	03/12/2026	UNITED DATA TECHNOLO		107.39	
141	72320	307	000	141236277	03/12/2026	UNITED DATA TECHNOLO		257.38	
141	72320	307	000	141236277	03/12/2026	UNITED DATA TECHNOLO		158.79	
141	73300	599	000	141236277	03/12/2026	UNITED DATA TECHNOLO		50.01	
141	72520	355	000	141236278	03/12/2026	UT CTR FOR CAREER DE		125.00	
141	72320	307	000	141236279	03/12/2026	VERIZON WIRELESS		43.61	
141	71300	429	000	141236280	03/12/2026	VEX ROBOTICS		1,118.74	
141	71300	429	000	141236280	03/12/2026	VEX ROBOTICS		2,379.26	
141	71300	730	000	141236280	03/12/2026	VEX ROBOTICS		1,459.98	
141	72120	355	000	141236281	03/12/2026	WAGNER, KELLY		74.68	
141	71300	429	000	141236283	03/12/2026	WESTEL GREENHOUSE, L		187.10	
141	72520	355	000	141236284	03/12/2026	WHITAKER, JERRY		45.11	
141	72220	355	000	141236285	03/12/2026	WOLFE, JACKI		129.05	
141	72210	524	000	141236285	03/12/2026	WOLFE, JACKI		200.00	
141	72210	524	000	141236285	03/12/2026	WOLFE, JACKI		398.75	
141	72210	524	000	141236285	03/12/2026	WOLFE, JACKI		245.07	
141	72210	355	000	141236286	03/12/2026	ZUEHLKE, JAN		145.00	
141	71100	599	000	141236291	03/13/2026	BLOOKET LLC		1,800.00	
141	72610	399	000	141236292	03/13/2026	BM SEPTIC TANK COMPA		400.00	
141	72210	355	000	141236293	03/13/2026	BOWDEN, MARY		69.02	
141	72320	399	000	141236294	03/13/2026	CAPTVEEVATION, INC		730.25	
141	72210	355	000	141236295	03/13/2026	CARR, MELINDA		143.55	
141	72610	599	000	141236296	03/13/2026	CINTAS		319.76	
141	72620	599	000	141236296	03/13/2026	CINTAS		1,688.22	
141	72710	599	000	141236296	03/13/2026	CINTAS		584.32	
141	72610	599	000	141236296	03/13/2026	CINTAS		404.64	
141	72610	599	000	141236296	03/13/2026	CINTAS		116.00	
141	72610	599	000	141236296	03/13/2026	CINTAS		290.92	
141	71100	449	000	141236297	03/13/2026	DCHS DIGITAL GRAPHIC		2,636.40	Classroom Materials Printing
141	71300	207	000	141236298	03/13/2026	ETSU		373.50	
141	71300	204	000	141236298	03/13/2026	ETSU		761.82	
141	71300	201	000	141236298	03/13/2026	ETSU		208.74	
141	71300	212	000	141236298	03/13/2026	ETSU		48.82	
141	71300	123	000	141236298	03/13/2026	ETSU		3,456.51	Reimburse Salaries; CTE ISM
141	71300	210	000	141236298	03/13/2026	ETSU		5.19	
141	72230	355	000	141236299	03/13/2026	HAULDREN, KELLI		110.20	
141	73300	355	000	141236300	03/13/2026	LANE, TINA		51.48	
141	72210	355	000	141236301	03/13/2026	LEONARD, JILL		33.35	
141	72620	499	000	141236302	03/13/2026	MARTIN MARIETTA MATE		414.64	
141	72210	355	000	141236303	03/13/2026	MILLER, JESSICA		86.28	
141	72620	499	000	141236304	03/13/2026	PIONEER ATHLETICS		1,645.68	
141	72210	355	000	141236305	03/13/2026	POORE, TAYLOR		46.40	
141	73300	355	000	141236306	03/13/2026	RICHARDSON, ABBY		39.88	
141	72620	499	000	141236308	03/13/2026	TMS SOUTH		1,072.91	
141	71100	399	000	141236309	03/13/2026	VILLAGE BEHAVIORAL H		315.00	

		CHECK CHECK					
FND	ACCT	OBJ	PRJ	NUMBER	DATE	VENDOR	AMOUNT
141	71100	399	000	141236309	03/13/2026	VILLAGE BEHAVIORAL H	882.00
141	72210	355	000	141236311	03/13/2026	WOODWARD, HANNAH	14.07
141	71100	299	000	141236314	03/17/2026	TASC	159.10
141	71100	299	000	141236315	03/18/2026	TASC	220.00
141	72710	453	000	141236316	03/19/2026	ADVANCE AUTO PARTS	2,772.89 <i>Vehicle Parts</i>
141	71300	429	000	141236317	03/19/2026	AIRGAS INC, SOUTH DI	29.05
141	72210	336	000	141236318	03/19/2026	AMAZON CAPITAL SERVI	283.62
141	72210	432	000	141236318	03/19/2026	AMAZON CAPITAL SERVI	1,592.61
141	72210	432	000	141236318	03/19/2026	AMAZON CAPITAL SERVI	33.99
141	72210	432	000	141236318	03/19/2026	AMAZON CAPITAL SERVI	795.24
141	72210	336	000	141236318	03/19/2026	AMAZON CAPITAL SERVI	29.99
141	72210	336	000	141236318	03/19/2026	AMAZON CAPITAL SERVI	39.40
141	72610	434	000	141236319	03/19/2026	ATMOS ENERGY	2,303.13
141	72210	524	000	141236320	03/19/2026	BANK CARD	249.32
141	72620	499	000	141236320	03/19/2026	BANK CARD	2,404.75
141	72130	524	000	141236320	03/19/2026	BANK CARD	358.00
141	72320	399	000	141236321	03/19/2026	BANKCARD	160.25
141	72710	599	000	141236321	03/19/2026	BANKCARD	188.58
141	72520	355	000	141236321	03/19/2026	BANKCARD	334.90
141	71100	599	000	141236322	03/19/2026	BLACKBURN, AMANDA	378.45
141	71100	599	000	141236322	03/19/2026	BLACKBURN, AMANDA	175.00
141	72620	336	000	141236323	03/19/2026	BLEACHERS & SEATS.CO	4,316.69
141	72620	336	000	141236323	03/19/2026	BLEACHERS & SEATS.CO	1,400.00
141	72610	415	000	141236324	03/19/2026	BRIGHT RIDGE	8,414.58
141	72610	415	000	141236324	03/19/2026	BRIGHT RIDGE	4,180.03
141	72610	415	000	141236324	03/19/2026	BRIGHT RIDGE	3,297.35
141	72610	415	000	141236324	03/19/2026	BRIGHT RIDGE	14,893.76
141	72610	415	000	141236324	03/19/2026	BRIGHT RIDGE	15,208.19
141	72610	415	000	141236324	03/19/2026	BRIGHT RIDGE	4,945.33
141	72610	415	000	141236324	03/19/2026	BRIGHT RIDGE	10,172.42
141	72610	415	000	141236324	03/19/2026	BRIGHT RIDGE	8,269.99
141	72610	415	000	141236324	03/19/2026	BRIGHT RIDGE	1,754.52
141	72610	415	000	141236324	03/19/2026	BRIGHT RIDGE	11,358.78
141	72610	415	000	141236324	03/19/2026	BRIGHT RIDGE	6,349.09
141	72610	415	000	141236324	03/19/2026	BRIGHT RIDGE	9,217.29
141	72610	415	000	141236324	03/19/2026	BRIGHT RIDGE	13,191.18
141	72610	415	000	141236324	03/19/2026	BRIGHT RIDGE	30,844.25
141	72610	415	000	141236324	03/19/2026	BRIGHT RIDGE	30,452.08
141	72610	415	000	141236324	03/19/2026	BRIGHT RIDGE	18,196.48
141	73400	599	000	141236325	03/19/2026	BRIGHT'S ZOO	231.00
141	73400	599	000	141236326	03/19/2026	BRIGHT'S ZOO	220.00
141	72220	355	000	141236327	03/19/2026	CAMPBELL, AMANDA	222.58
141	71100	499	000	141236328	03/19/2026	CAROLINA BIOLOGICAL	526.48
141	71100	499	000	141236328	03/19/2026	CAROLINA BIOLOGICAL	13.80
141	71100	499	000	141236328	03/19/2026	CAROLINA BIOLOGICAL	362.26
141	71100	499	000	141236328	03/19/2026	CAROLINA BIOLOGICAL	1,133.07
141	72220	355	000	141236329	03/19/2026	CHAPMAN, JOHANNA	222.58
141	72210	524	000	141236330	03/19/2026	CHRISTIAN, AARON	100.00
141	72210	524	000	141236330	03/19/2026	CHRISTIAN, AARON	435.00
141	72610	599	000	141236331	03/19/2026	CINTAS	804.68
141	72610	599	000	141236331	03/19/2026	CINTAS	130.60
141	72250	399	000	141236332	03/19/2026	CIVICPLUS LLC	8,211.03
141	71100	599	000	141236333	03/19/2026	CROWE, ASHLYN	175.00
141	72220	355	000	141236334	03/19/2026	DUNCAN, CYNTHIA	68.15
141	71300	730	000	141236335	03/19/2026	DYNAMISM INC	1,677.00
141	72110	355	000	141236336	03/19/2026	EMBASSY SUITES	643.06

> Fall Branch Bleachers Parts/Repairs

Athletic Tournament Management Renewal

		CHECK CHECK					
FND	ACCT	OBJ	PRJ	NUMBER	DATE	VENDOR	AMOUNT
141	72250	355	000	141236336	03/19/2026	EMBASSY SUITES	590.71
141	71300	429	000	141236337	03/19/2026	fbrc8	1,427.00
141	71300	730	000	141236337	03/19/2026	fbrc8	3,998.00
141	72610	399	000	141236338	03/19/2026	FLEENOR SECURITY SYS	29.99
141	71300	429	000	141236339	03/19/2026	GOVCONNECTION, INC	2,533.00
141	71300	429	000	141236339	03/19/2026	GOVCONNECTION, INC	-148.00
141	71300	730	000	141236339	03/19/2026	GOVCONNECTION, INC	9,184.85
141	71100	722	000	141236339	03/19/2026	GOVCONNECTION, INC	1,174.83
141	72250	499	000	141236339	03/19/2026	GOVCONNECTION, INC	3,021.06
141	72610	328	000	141236340	03/19/2026	HES FACILITIES	17,680.24
141	72610	328	000	141236340	03/19/2026	HES FACILITIES	11,512.72
141	72610	328	000	141236340	03/19/2026	HES FACILITIES	6,578.69
141	72610	328	000	141236340	03/19/2026	HES FACILITIES	10,690.38
141	72610	328	000	141236340	03/19/2026	HES FACILITIES	17,675.35
141	72610	328	000	141236340	03/19/2026	HES FACILITIES	9,868.03
141	72610	328	000	141236340	03/19/2026	HES FACILITIES	7,812.21
141	72610	328	000	141236340	03/19/2026	HES FACILITIES	8,223.37
141	72610	328	000	141236340	03/19/2026	HES FACILITIES	7,812.21
141	72610	328	000	141236340	03/19/2026	HES FACILITIES	18,913.75
141	72610	328	000	141236340	03/19/2026	HES FACILITIES	18,913.75
141	72610	328	000	141236340	03/19/2026	HES FACILITIES	11,512.72
141	71300	429	000	141236341	03/19/2026	J&P PARK ACQUISITION	564.37
141	71300	429	000	141236341	03/19/2026	J&P PARK ACQUISITION	280.30
141	71100	599	000	141236342	03/19/2026	JARRETT, RACHEL	175.00
141	72610	399	000	141236343	03/19/2026	JB DIRT WORKS	2,300.00
141	71100	399	000	141236344	03/19/2026	LANGUAGE TRAINING CE	212.50
141	72610	399	000	141236345	03/19/2026	LEO'S PEST CONTROL	795.00
141	71300	429	000	141236346	03/19/2026	MSC INDUSTRIAL SUPPL	997.49
141	72250	499	000	141236347	03/19/2026	ODP BUSINESS SOLUTIO	511.30
141	72250	499	000	141236347	03/19/2026	ODP BUSINESS SOLUTIO	382.19
141	72250	499	000	141236347	03/19/2026	ODP BUSINESS SOLUTIO	88.85
141	72250	499	000	141236347	03/19/2026	ODP BUSINESS SOLUTIO	88.07
141	72250	499	000	141236347	03/19/2026	ODP BUSINESS SOLUTIO	801.31
141	72250	499	000	141236347	03/19/2026	ODP BUSINESS SOLUTIO	118.04
141	72250	499	000	141236347	03/19/2026	ODP BUSINESS SOLUTIO	176.14
141	71300	429	000	141236348	03/19/2026	PENN STATE INDUSTRIE	565.55
141	72710	425	000	141236349	03/19/2026	PERCELL, DAVID	89.00
141	72320	348	000	141236350	03/19/2026	PITNEY BOWES PURCHAS	1,126.14
141	71300	730	000	141236351	03/19/2026	PRESENTATION SOLUTIO	5,245.05
141	71100	599	000	141236352	03/19/2026	RICHARDSON, CHERYL	175.00
141	71100	599	000	141236352	03/19/2026	RICHARDSON, CHERYL	378.45
141	72310	599	000	141236353	03/19/2026	RIVERS, KIM	127.58
141	71100	599	000	141236354	03/19/2026	SCHNELLE, CHRISTA	175.00
141	71300	730	000	141236355	03/19/2026	SPHERO INC	3,776.89
141	72220	599	000	141236356	03/19/2026	ST JOHN, SEBRENA	274.57
141	72610	399	000	141236357	03/19/2026	STATE OF TENNESSEE	60.00
141	71300	429	000	141236358	03/19/2026	STEMFINITY LLC	879.95
141	71300	429	000	141236359	03/19/2026	SWEETWATER	709.96
141	72620	599	000	141236360	03/19/2026	TEG ENTERPRISES	105.00
141	72250	499	000	141236361	03/19/2026	TELE-OPTICS	1,611.00
141	72310	320	000	141236362	03/19/2026	TENN SCHOOL BOARDS A	8,271.00
141	72220	355	000	141236363	03/19/2026	THOMPSON, LESLIE	129.05
141	72620	499	000	141236364	03/19/2026	TMS SOUTH	123.73
141	72620	499	000	141236364	03/19/2026	TMS SOUTH	1,400.34
141	72610	359	000	141236365	03/19/2026	TOWN OF JONESBOROUGH	125.00
141	72610	454	000	141236365	03/19/2026	TOWN OF JONESBOROUGH	83.85

Classroom Equipment; Ridgeview; CTE ISM

Classroom Equipment; JES; CTE ISM

6 Chromebooks & Licenses; Tech Dept Stock

Custodial Services

Classroom Equipment; South Central; CTE ISM

Classroom Equipment; Ridgeview; CTE ISM

Annual Membership Dues

		CHECK CHECK					
FND	ACCT	OBJ	PRJ	NUMBER	DATE	VENDOR	AMOUNT
141	72250	499	000	141236366	03/19/2026	UNITED DATA TECHNOLO	280.00
141	99100	590	000	141236367	03/19/2026	WASHINGTON COUNTY DEBT	28,241.00
141	72610	499	000	141236368	03/19/2026	WASHINGTON FARMERS C	5,599.30
141	72120	499	000	141236371	03/25/2026	BANK CARD	1,230.56
141	72310	331	000	141236372	03/25/2026	BENNETT & DECAMP PLL	4,500.00
141	72220	355	000	141236373	03/25/2026	CAMPBELL, AMANDA	198.80
141	72220	355	000	141236373	03/25/2026	CAMPBELL, AMANDA	223.30
141	72230	355	000	141236374	03/25/2026	COLLETTE, AMY	78.30
141	72230	355	000	141236374	03/25/2026	COLLETTE, AMY	78.30
141	72230	355	000	141236375	03/25/2026	DRINNON, SHANNON	92.66
141	72520	355	000	141236376	03/25/2026	ETSU UNIV CAREER SER	150.00
141	72620	335	000	141236377	03/25/2026	FINCHUM SPORTS FLOOR	7,335.00
141	72620	335	000	141236377	03/25/2026	FINCHUM SPORTS FLOOR	4,116.00
141	72210	355	000	141236378	03/25/2026	GARST, ANGELA	141.85
141	72620	335	000	141236379	03/25/2026	K & M FLOORING	20,260.40
141	72520	355	000	141236393	03/25/2026	NORTHEAST TENN SHRM	20.00
141	72520	355	000	141236393	03/25/2026	NORTHEAST TENN SHRM	17.00
141	72320	348	000	141236380	03/25/2026	PITNEY BOWES GLOBAL	848.43
141	72120	355	000	141236381	03/25/2026	SALYER, WENDI	239.98
141	71100	599	000	141236382	03/25/2026	SIMONS, CATHERINE	26.01
141	71300	429	000	141236383	03/25/2026	STEMFINITY LLC	762.95
141	72520	355	000	141236384	03/25/2026	UNIVERSITY OF TENNES	125.00
141	72710	330	000	141236385	03/25/2026	WESTERN EQUIPMENT FI	2,981.09
141	71100	217	000	141236395	03/26/2026	TENN CONSOLIDATED RE	13,360.29
141	71100	210	000	141236396	03/26/2026	TN DEPT OF LABOR & W	2,732.85
141	72620	499	000	141236398	03/27/2026	ALUMINUM & GLASS SYS	2,419.60
141	72710	453	000	141236399	03/27/2026	AMAZON CAPITAL SERVI	738.34
141	71100	499	000	141236399	03/27/2026	AMAZON CAPITAL SERVI	-116.07
141	72210	432	000	141236399	03/27/2026	AMAZON CAPITAL SERVI	-59.16
141	71300	429	000	141236399	03/27/2026	AMAZON CAPITAL SERVI	100.93
141	71300	429	000	141236399	03/27/2026	AMAZON CAPITAL SERVI	32.16
141	71300	429	000	141236399	03/27/2026	AMAZON CAPITAL SERVI	68.37
141	71300	429	000	141236399	03/27/2026	AMAZON CAPITAL SERVI	900.92
141	71300	730	000	141236399	03/27/2026	AMAZON CAPITAL SERVI	1,329.68
141	72250	499	000	141236399	03/27/2026	AMAZON CAPITAL SERVI	127.78
141	72250	499	000	141236399	03/27/2026	AMAZON CAPITAL SERVI	382.16
141	72250	499	000	141236399	03/27/2026	AMAZON CAPITAL SERVI	15.98
141	72250	499	000	141236399	03/27/2026	AMAZON CAPITAL SERVI	338.85
141	72320	435	000	141236399	03/27/2026	AMAZON CAPITAL SERVI	35.99
141	71100	499	000	141236399	03/27/2026	AMAZON CAPITAL SERVI	203.37
141	71100	429	000	141236399	03/27/2026	AMAZON CAPITAL SERVI	483.45
141	71100	429	000	141236399	03/27/2026	AMAZON CAPITAL SERVI	967.38
141	72210	524	000	141236399	03/27/2026	AMAZON CAPITAL SERVI	45.59
141	72210	524	000	141236399	03/27/2026	AMAZON CAPITAL SERVI	156.46
141	72210	524	000	141236399	03/27/2026	AMAZON CAPITAL SERVI	90.66
141	71300	429	000	141236399	03/27/2026	AMAZON CAPITAL SERVI	24.99
141	71300	429	000	141236399	03/27/2026	AMAZON CAPITAL SERVI	729.05
141	71300	429	000	141236399	03/27/2026	AMAZON CAPITAL SERVI	302.06
141	71300	429	000	141236399	03/27/2026	AMAZON CAPITAL SERVI	294.90
141	71300	429	000	141236399	03/27/2026	AMAZON CAPITAL SERVI	288.93
141	72810	599	000	141236399	03/27/2026	AMAZON CAPITAL SERVI	413.77
141	72620	499	000	141236399	03/27/2026	AMAZON CAPITAL SERVI	60.99
141	72620	499	000	141236399	03/27/2026	AMAZON CAPITAL SERVI	977.69
141	72620	499	000	141236399	03/27/2026	AMAZON CAPITAL SERVI	119.70
141	72620	499	000	141236399	03/27/2026	AMAZON CAPITAL SERVI	127.92
141	71100	722	000	141236402	03/27/2026	AMITRACE	14,995.00

EESI Payment #46

Bullfield mtnc Materials

Gymn Floor Mtnc; BCE
" " " ; Fall Branch

Sulphur Springs Cafeteria

Lease Payment; Ex-Mark Mowers

Stabilization Rate Payment
Unemployment Claims

Classroom Equipment; Grandview; CTE ISM

		CHECK CHECK					
FND	ACCT	OBJ	PRJ	NUMBER	DATE	VENDOR	AMOUNT
141	72320	399	000	141236403	03/27/2026	BALLAD HEALTH BUSINE	195.00
141	72620	399	000	141236404	03/27/2026	BARNARD ROOFING	480.00
141	71100	499	000	141236405	03/27/2026	BOONES CREEK ELEMENT	199.00
141	72620	499	000	141236406	03/27/2026	BRANHAM INDUSTRIAL L	86.65
141	72620	399	000	141236407	03/27/2026	CES CORPORATION	160.00
141	72620	499	000	141236408	03/27/2026	E.S. DOCKERY, INC	3,560.00
141	72620	399	000	141236410	03/27/2026	ESKOLA LLC	479.60
141	71100	399	000	141236411	03/27/2026	ETSU UNIVERSITY SCHO	777,620.76
141	71100	499	000	141236412	03/27/2026	FALL BRANCH SCHOOL	206.50
141	72710	424	000	141236413	03/27/2026	FAST SIGNS	971.94
141	72710	424	000	141236413	03/27/2026	FAST SIGNS	600.27
141	72620	599	000	141236415	03/27/2026	FOSTER SIGNS	1,150.20
141	71100	722	000	141236416	03/27/2026	GOVCONNECTION, INC	4,001.85
141	71100	722	000	141236416	03/27/2026	GOVCONNECTION, INC	1,174.83
141	71300	429	000	141236416	03/27/2026	GOVCONNECTION, INC	2,476.00
141	71100	499	000	141236417	03/27/2026	GRANDVIEW ELEMENTARY	199.00
141	71100	499	000	141236418	03/27/2026	GRAY ELEMENTARY SCHO	199.00
141	72610	499	000	141236419	03/27/2026	GREENE COUNTY KUBOTA	105.66
141	71300	429	000	141236420	03/27/2026	GRIMCO INC	310.98
141	71300	429	000	141236420	03/27/2026	GRIMCO INC	2,625.00
141	76100	707	000	141236421	03/27/2026	INSPIRE BUSINESS INT	44,500.00
141	72620	499	000	141236421	03/27/2026	INSPIRE BUSINESS INT	21,417.91
141	72320	399	000	141236422	03/27/2026	INSTRUCTURE INC	275.07
141	72250	499	000	141236423	03/27/2026	INTERWORLD HIGHWAY L	6,723.56
141	72610	454	000	141236424	03/27/2026	JOHNSON CITY UTILITY	5,185.64
141	72610	454	000	141236424	03/27/2026	JOHNSON CITY UTILITY	1,375.28
141	72610	454	000	141236424	03/27/2026	JOHNSON CITY UTILITY	3,796.80
141	72610	454	000	141236424	03/27/2026	JOHNSON CITY UTILITY	991.25
141	72610	359	000	141236424	03/27/2026	JOHNSON CITY UTILITY	1,378.75
141	72610	359	000	141236424	03/27/2026	JOHNSON CITY UTILITY	202.50
141	72610	359	000	141236424	03/27/2026	JOHNSON CITY UTILITY	249.06
141	72610	359	000	141236424	03/27/2026	JOHNSON CITY UTILITY	371.88
141	72610	359	000	141236424	03/27/2026	JOHNSON CITY UTILITY	594.00
141	72610	359	000	141236424	03/27/2026	JOHNSON CITY UTILITY	371.25
141	72610	359	000	141236424	03/27/2026	JOHNSON CITY UTILITY	371.25
141	72610	359	000	141236424	03/27/2026	JOHNSON CITY UTILITY	700.00
141	72610	359	000	141236424	03/27/2026	JOHNSON CITY UTILITY	329.87
141	72610	359	000	141236424	03/27/2026	JOHNSON CITY UTILITY	229.69
141	72610	359	000	141236424	03/27/2026	JOHNSON CITY UTILITY	288.33
141	72610	359	000	141236424	03/27/2026	JOHNSON CITY UTILITY	160.28
141	72610	359	000	141236424	03/27/2026	JOHNSON CITY UTILITY	191.77
141	72610	359	000	141236424	03/27/2026	JOHNSON CITY UTILITY	135.26
141	72610	359	000	141236424	03/27/2026	JOHNSON CITY UTILITY	119.24
141	72610	454	000	141236424	03/27/2026	JOHNSON CITY UTILITY	617.77
141	72610	359	000	141236424	03/27/2026	JOHNSON CITY UTILITY	9,692.00
141	71100	499	000	141236425	03/27/2026	JONESBOROUGH ELEMENT	199.00
141	71100	499	000	141236426	03/27/2026	LAMAR SCHOOL	199.00
141	72310	399	000	141236427	03/27/2026	LEWIS GROUP ARCHITEC	2,168.20
141	72310	399	000	141236427	03/27/2026	LEWIS GROUP ARCHITEC	93.75
141	72310	399	000	141236427	03/27/2026	LEWIS GROUP ARCHITEC	937.50
141	72620	499	000	141236428	03/27/2026	MODERN SUPPLY	2,350.00
141	72210	432	000	141236429	03/27/2026	MR. K'S USED BOOKS	197.60
141	72610	399	000	141236430	03/27/2026	NORTON'S PEST CONTRO	100.00
141	71100	206	000	141236431	03/27/2026	AMERICAN UNITED LIFE	1,500.00
141	71100	299	000	141236431	03/27/2026	AMERICAN UNITED LIFE	3,079.71
141	71200	206	000	141236431	03/27/2026	AMERICAN UNITED LIFE	281.00

mtnce Dept Materials

Revenue Sharing; FEBRUARY

Classroom Equipment; Ridgeview; CTE ISM

Classroom Supplies; DBHS

Cafeteria Tables & Chairs; Sulphur Springs

Fusion Splicer

Board Provided Life Insurance

		CHECK CHECK					
FND	ACCT	OBJ	PRJ	NUMBER	DATE	VENDOR	AMOUNT
141	71300	206	000	141236431	03/27/2026	AMERICAN UNITED LIFE	130.50
141	72110	206	000	141236431	03/27/2026	AMERICAN UNITED LIFE	4.40
141	72120	206	000	141236431	03/27/2026	AMERICAN UNITED LIFE	44.30
141	72130	206	000	141236431	03/27/2026	AMERICAN UNITED LIFE	77.80
141	72210	206	000	141236431	03/27/2026	AMERICAN UNITED LIFE	92.10
141	72230	206	000	141236431	03/27/2026	AMERICAN UNITED LIFE	6.10
141	72320	206	000	141236431	03/27/2026	AMERICAN UNITED LIFE	17.40
141	72410	206	000	141236431	03/27/2026	AMERICAN UNITED LIFE	179.50
141	72510	206	000	141236431	03/27/2026	AMERICAN UNITED LIFE	6.00
141	72610	206	000	141236431	03/27/2026	AMERICAN UNITED LIFE	69.50
141	72620	206	000	141236431	03/27/2026	AMERICAN UNITED LIFE	28.10
141	72710	206	000	141236431	03/27/2026	AMERICAN UNITED LIFE	151.70
141	72810	206	000	141236431	03/27/2026	AMERICAN UNITED LIFE	7.60
141	72250	206	000	141236431	03/27/2026	AMERICAN UNITED LIFE	47.90
141	72210	432	000	141236432	03/27/2026	PERMA-BOUND	37.60
141	72210	432	000	141236432	03/27/2026	PERMA-BOUND	103.40
141	72210	432	000	141236432	03/27/2026	PERMA-BOUND	206.80
141	72210	432	000	141236432	03/27/2026	PERMA-BOUND	94.49
141	72710	399	000	141236433	03/27/2026	PONDER AUTO REPAIR	120.28
141	72620	499	000	141236434	03/27/2026	PUREMAXX LLC	866.76
141	72620	499	000	141236434	03/27/2026	PUREMAXX LLC	1,005.07
141	72620	499	000	141236434	03/27/2026	PUREMAXX LLC	466.73
141	71100	499	000	141236435	03/27/2026	RIDGEVIEW SCHOOL	206.50
141	71200	429	000	141236436	03/27/2026	RIVERSIDE INSIGHTS	371.62
141	72220	399	000	141236437	03/27/2026	SIDEKICK THERAPY PAR	316.00
141	72610	399	000	141236438	03/27/2026	SOUTH EAST TN HAULIN	450.00
141	72610	399	000	141236438	03/27/2026	SOUTH EAST TN HAULIN	675.00
141	71100	499	000	141236439	03/27/2026	SULPHUR SPRINGS SCHO	206.50
141	72250	499	000	141236440	03/27/2026	TELE-OPTICS	3,415.95 <i>Outdoor Security System Camera; Sulphur Springs</i>
141	72620	336	000	141236441	03/27/2026	TMH MIDSOUTH	944.42
141	72620	499	000	141236442	03/27/2026	TMS SOUTH	949.21
141	72620	499	000	141236442	03/27/2026	TMS SOUTH	1,781.76
141	72610	454	000	141236443	03/27/2026	TOWN OF JONESBOROUGH	39.76
141	72610	454	000	141236443	03/27/2026	TOWN OF JONESBOROUGH	560.71
141	72610	454	000	141236443	03/27/2026	TOWN OF JONESBOROUGH	50.13
141	72610	359	000	141236443	03/27/2026	TOWN OF JONESBOROUGH	125.00
141	72610	454	000	141236443	03/27/2026	TOWN OF JONESBOROUGH	86.75
141	72610	359	000	141236443	03/27/2026	TOWN OF JONESBOROUGH	375.00
141	72610	454	000	141236443	03/27/2026	TOWN OF JONESBOROUGH	107.05
141	72610	454	000	141236443	03/27/2026	TOWN OF JONESBOROUGH	1,077.09
141	72610	359	000	141236443	03/27/2026	TOWN OF JONESBOROUGH	750.00
141	72610	454	000	141236443	03/27/2026	TOWN OF JONESBOROUGH	23.00
141	72610	454	000	141236443	03/27/2026	TOWN OF JONESBOROUGH	23.00
141	72610	454	000	141236443	03/27/2026	TOWN OF JONESBOROUGH	354.14
141	72610	454	000	141236443	03/27/2026	TOWN OF JONESBOROUGH	315.01
141	71300	730	000	141236444	03/27/2026	TRU TECH TOOLS	6,210.77 <i>Classroom Equipment; DBHS; CTE ISM</i>
141	72620	499	000	141236446	03/27/2026	UNITED REFRIGERATION	1,937.33
141	71100	499	000	141236448	03/27/2026	WEST VIEW SCHOOL	199.00
141	71300	429	000	141236449	03/27/2026	XTL US INC	100.00
Totals for checks							1,818,471.72

FUND SUMMARY

<u>FUND</u>	<u>DESCRIPTION</u>	<u>BALANCE SHEET</u>	<u>REVENUE</u>	<u>EXPENSE</u>	<u>TOTAL</u>
141	GENERAL PURPOSE SCHOOL	0.00	0.00	1,818,471.72	1,818,471.72
***	Fund Summary Totals ***	0.00	0.00	1,818,471.72	1,818,471.72

***** End of report *****

Account Level						2025-26	March 2025-26	2025-26	Encumbered	Unexpended	2025-26		
Fnd	T	Acct	Obj	Prj	Loc	Prg	Description	Budget	Monthly Activity	FYTD Activity	Amount	Balance - YTD Act	FYTD %
71100							REGULAR INSTRUCTION						
141	E	71100	429	000	00000	300	ESTU SLICE GRANT	0.00	0.00	0.00	0.00	0.00	0.00
141	E	71100	429	000	00002	000	INSTRUCTIONAL SUPPLIES-ASBURY	0.00	0.00	3,229.72	0.00	-3,229.72	0.00
141	E	71100	429	000	00003	000	INSTRUCTIONAL SUPPLIES-MIDWAY	0.00	0.00	0.00	0.00	0.00	0.00
141	E	71100	429	000	00004	000	INSTRUCTIONAL SUPPLIES-BCES	0.00	0.00	16,162.74	0.00	-16,162.74	0.00
141	E	71100	429	000	00005	000	INSTRUCTIONAL SUPPLIES-BCMS	0.00	0.00	0.00	0.00	0.00	0.00
141	E	71100	429	000	00006	000	INSTRUCTIONAL SUPPLIES-GVES	0.00	0.00	19,170.76	0.00	-19,170.76	0.00
141	E	71100	429	000	00007	000	INSTRUCTIONAL SUPPLIES-FBES	0.00	0.00	9,900.08	0.00	-9,900.08	0.00
141	E	71100	429	000	00008	000	INSTRUCTIONAL SUPPLIES-GES	0.00	2,230.04	14,132.80	0.00	-14,132.80	0.00
141	E	71100	429	000	00009	000	INSTRUCTIONAL SUPPLIES-JES	0.00	6,414.53	28,551.04	0.00	-28,551.04	0.00
141	E	71100	429	000	00010	000	INSTRUCTIONAL SUPPLIES-JMS	0.00	0.00	0.00	0.00	0.00	0.00
141	E	71100	429	000	00011	000	INSTRUCTIONAL SUPPLIES-LES	0.00	0.00	13,421.54	0.00	-13,421.54	0.00
141	E	71100	429	000	00012	000	INSTRUCTIONAL SUPPLIES-SCES	0.00	0.00	5,943.97	0.00	-5,943.97	0.00
141	E	71100	429	000	00013	000	INSTRUCTIONAL SUPPLIES-SSES	0.00	0.00	13,210.88	0.00	-13,210.88	0.00
141	E	71100	429	000	00014	000	INSTRUCTIONAL SUPPLIES-WVES	0.00	0.00	11,372.66	0.00	-11,372.66	0.00
141	E	71100	429	000	00015	000	INSTRUCTIONAL SUPPLIES-DBHS	0.00	0.00	19,233.61	0.00	-19,233.61	0.00
141	E	71100	429	000	00016	000	INSTRUCTIONAL SUPPLIES-DCHS	0.00	1,450.83	28,516.00	0.00	-28,516.00	0.00
141	E	71100	429	000	00025	000	INSTRUCTIONAL SUPPLIES-RVES	0.00	0.00	15,401.28	0.00	-15,401.28	0.00
141	E	71100	449	000	00000	000	TEXTBOOKS	1,200,000.00	3,328.93	232,165.53	0.00	967,834.47	19.35
141	E	71100	499	000	00000	000	OTHER SUPPLIES AND MATERIALS	588,000.00	1,813.50	161,918.07	0.00	426,081.93	27.54
141	E	71100	499	000	00000	002	CTE ISM GRANT	0.00	0.00	0.00	0.00	0.00	0.00
141	E	71100	499	000	00000	003	Supplies-Summer Learning	0.00	0.00	0.00	0.00	0.00	0.00
141	E	71100	499	000	00000	005	SUPPLIES-STEM GRANTS	0.00	0.00	0.00	0.00	0.00	0.00
141	E	71100	499	000	00000	100	OTHER SUPPLIES-CIVICS GRANT	0.00	0.00	0.00	0.00	0.00	0.00
141	E	71100	499	000	00000	200	GRANT FUNDS	0.00	0.00	0.00	0.00	0.00	0.00
141	E	71100	499	000	00000	300	ETSU SLICE-SIUPPLIES	0.00	0.00	0.00	0.00	0.00	0.00
141	E	71100	499	000	00000	802	INSTR. SCIENCE CLASS SUPPLIES	24,000.00	2,788.72	19,273.63	0.00	4,726.37	80.31
141	E	71100	499	000	00002	000	OTHER SUPPLIES & MAT.-ASBURY	0.00	0.00	0.00	0.00	0.00	0.00
141	E	71100	499	000	00003	000	OTHER SUPPLIES & MAT.-MIDWAY	0.00	0.00	0.00	0.00	0.00	0.00
141	E	71100	499	000	00004	000	OTHER SUPPLIES & MAT.-BCES	0.00	0.00	1,770.50	0.00	-1,770.50	0.00
141	E	71100	499	000	00005	000	OTHER SUPPLIES & MAT.-BCMS	0.00	0.00	0.00	0.00	0.00	0.00
141	E	71100	499	000	00006	000	OTHER SUPPLIES & MAT.-GVES	0.00	0.00	3,423.72	0.00	-3,423.72	0.00
141	E	71100	499	000	00007	000	OTHER SUPPLIES & MAT.-FBES	0.00	0.00	3,466.74	0.00	-3,466.74	0.00
141	E	71100	499	000	00008	000	OTHER SUPPLIES & MAT.-GES	0.00	0.00	2,500.00	0.00	-2,500.00	0.00
141	E	71100	499	000	00009	000	OTHER SUPPLIES & MAT.-JES	0.00	0.00	1,777.02	0.00	-1,777.02	0.00
141	E	71100	499	000	00010	000	OTHER SUPPLIES & MAT.-JMS	0.00	0.00	0.00	0.00	0.00	0.00
141	E	71100	499	000	00011	000	OTHER SUPPLIES & MAT.-LES	0.00	0.00	135.40	0.00	-135.40	0.00
141	E	71100	499	000	00012	000	OTHER SUPPLIES & MAT.-SCES	0.00	0.00	5,500.00	0.00	-5,500.00	0.00
141	E	71100	499	000	00013	000	OTHER SUPPLIES & MAT.-SSES	0.00	0.00	3,011.00	0.00	-3,011.00	0.00

Fnd T	Acct	Obj	Prj	Loc	Prg	Account Level Description	2025-26 Budget	March 2025-26 Monthly Activity	2025-26 FYTD Activity	Encumbered Amount	Unexpended Balance - YTD Act	2025-26 FYTD %
71100						REGULAR INSTRUCTION						
141 E	71100	499	000	00014	000	OTHER SUPPLIES & MAT.-WVES	0.00	0.00	283.78	0.00	-283.78	0.00
141 E	71100	499	000	00015	000	OTHER SUPPLIES & MAT.-DBHS	0.00	289.87	13,639.50	0.00	-13,639.50	0.00
141 E	71100	499	000	00016	000	OTHER SUPPLIES & MAT.-DCHS	0.00	2,108.52	11,335.84	0.00	-11,335.84	0.00
141 E	71100	499	000	00017	000	OTHER SUPPLIES & MAT-UH	0.00	0.00	0.00	0.00	0.00	0.00
141 E	71100	499	000	00025	000	OTHER SUPPLIES & MAT.-RVES	0.00	0.00	1,199.58	0.00	-1,199.58	0.00
141 E	71100	595	000	00000	000	JDC	0.00	0.00	0.00	0.00	0.00	0.00
141 E	71100	599	000	00000	000	OTHER CHARGES	898,572.13	0.00	0.00	0.00	898,572.13	0.00
141 E	71100	599	000	00000	003	Supplies-Summer Learning	0.00	0.00	0.00	0.00	0.00	0.00
141 E	71100	599	000	00000	025	OTHER CHARGES	0.00	0.00	0.00	0.00	0.00	0.00
141 E	71100	599	000	00002	000	ASBURY	932.19	0.00	0.00	0.00	932.19	0.00
141 E	71100	599	000	00004	000	BOONES CREEK ELEMENTARY	11,610.91	2,384.00	3,134.00	0.00	8,476.91	26.99
141 E	71100	599	000	00006	000	GRANDVIEW	7,439.27	1,826.01	1,826.01	0.00	5,613.26	24.55
141 E	71100	599	000	00007	000	FALL BRANCH	3,167.39	0.00	2,550.83	0.00	616.56	80.53
141 E	71100	599	000	00008	000	GRAY ELEMENTARY	7,261.84	3,005.00	3,005.00	0.00	4,256.84	41.38
141 E	71100	599	000	00009	000	JONESBOROUGH ELEMENTARY	14,312.13	0.00	14,200.00	0.00	112.13	99.22
141 E	71100	599	000	00011	000	LAMAR	4,429.01	0.00	2,993.76	0.00	1,435.25	67.59
141 E	71100	599	000	00012	000	SOUTH CENTRAL	1,910.86	0.00	2,951.25	0.00	-1,040.39	154.45
141 E	71100	599	000	00013	000	SULPHER SPRINGS	4,664.33	0.00	5,852.00	0.00	-1,187.67	125.46
141 E	71100	599	000	00014	000	WESTVIEW	2,552.74	1,631.90	5,916.30	0.00	-3,363.56	231.76
141 E	71100	599	000	00015	000	DANIEL BOONE HIGH	5,058.27	0.00	18,180.00	0.00	-13,121.73	359.41
141 E	71100	599	000	00016	000	DAVID CROCKETT HIGH	4,440.55	0.00	12,950.00	0.00	-8,509.45	291.63
141 E	71100	599	000	00017	000	UNIVERSITY SCHOOL-UH	7,572.21	0.00	0.00	0.00	7,572.21	0.00
141 E	71100	599	000	00025	000	RIDGEVIEW	10,075.17	0.00	5,583.60	0.00	4,491.57	55.42
141 E	71100	708	000	00000	000	COMMUNICATIONS EQUIPMENT	160,000.00	0.00	0.00	0.00	160,000.00	0.00
141 E	71100	722	000	00000	002	CTE ISM GRANT	418,859.00	26,615.94	143,686.78	0.00	275,172.22	34.30
141 E	71100	---	---	-----	---		53,186,032.00	4,455,306.69	32,592,340.44	0.00	20,593,691.56	61.28
							=====	=====	=====	=====	=====	=====
71200						SPECIAL EDUCATION PROGRAM						
141 E	71200	116	000	00000	000	SP.ED. TEACHERS	3,437,144.00	279,273.31	1,994,595.88	0.00	1,442,548.12	58.03
141 E	71200	117	000	00000	000	CAREER LADDER PROGRAM	12,000.00	0.00	500.00	0.00	11,500.00	4.17
141 E	71200	128	000	00000	000	HOMEBOUND TEACHERS	20,400.00	0.00	0.00	0.00	20,400.00	0.00
141 E	71200	163	000	00000	000	EDUCATIONAL ASSISTANTS	1,261,937.00	105,112.57	745,915.84	0.00	516,021.16	59.11
141 E	71200	163	000	00000	912	EDUCATIONAL ASSISTANTS SPED PR	83,000.00	5,235.40	32,273.98	0.00	50,726.02	38.88
141 E	71200	171	000	00000	000	SPEECH PATHOLOGIST	269,886.00	0.00	0.00	0.00	269,886.00	0.00

Account Level						2025-26	March 2025-26	2025-26	Encumbered	Unexpended	2025-26
Fnd T Acct	Obj Prj Loc	Prg	Description	Budget	Monthly Activity	FYTD Activity	Amount	Balance - YTD Act	FYTD %		
71200	SPECIAL EDUCATION PROGRAM										
141 E 71200 188 000 00000 000	BONUS	0.00	0.00	112,000.00	0.00	-112,000.00	0.00				
141 E 71200 189 000 00000 000	OTHER SALARIES	182,111.00	13,253.08	110,615.97	0.00	71,495.03	60.74				
141 E 71200 195 000 00000 000	CERTIFIED SUBSTITUTE TEACHERS	20,000.00	0.00	0.00	0.00	20,000.00	0.00				
141 E 71200 195 995 00000 000	WCDE RETIRED SUBSTITUTE TEACHE	0.00	0.00	0.00	0.00	0.00	0.00				
141 E 71200 198 000 00000 000	NON-CERTIFIED SUBSTITUTE TEACH	65,000.00	0.00	0.00	0.00	65,000.00	0.00				
141 E 71200 201 000 00000 000	SOCIAL SECURITY	326,646.00	23,076.81	172,911.14	0.00	153,734.86	52.94				
141 E 71200 201 000 00000 912	SOCIAL SECURITY SPED PR	5,146.00	307.39	1,939.94	0.00	3,206.06	37.70				
141 E 71200 204 000 00000 000	STATE RETIREMENT	406,235.00	35,902.73	262,563.02	0.00	143,671.98	64.63				
141 E 71200 204 000 00000 912	STATE RETIREMENT SPED PR	10,948.00	690.55	4,299.63	0.00	6,648.37	39.27				
141 E 71200 206 000 00000 000	LIFE INSURANCE	3,000.00	281.00	1,967.00	0.00	1,033.00	65.57				
141 E 71200 207 000 00000 000	MEDICAL INSURANCE	720,230.00	97,410.92	663,887.07	0.00	56,342.93	92.18				
141 E 71200 207 000 00000 912	MEDICAL INSURANCE SPED PR	28,535.00	0.00	0.00	0.00	28,535.00	0.00				
141 E 71200 212 000 00000 000	EMPLOYER MEDICARE	76,393.00	5,397.03	40,438.97	0.00	35,954.03	52.94				
141 E 71200 212 000 00000 912	MEDICARE SPED PR	1,203.00	71.89	453.69	0.00	749.31	37.71				
141 E 71200 299 000 00000 000	OTHER FRINGE BENEFITS	0.00	0.00	0.00	0.00	0.00	0.00				
141 E 71200 399 000 00000 000	OTHER CONTRACTED SERVICES	0.00	0.00	0.00	0.00	0.00	0.00				
141 E 71200 429 000 00000 000	INSTRUCTIONAL SUPPLIES & MATER	22,400.00	700.07	18,381.85	0.00	4,018.15	82.06				
141 E 71200 429 000 00000 912	SUPPLIES AND MATERIALS SPED PR	5,000.00	0.00	0.00	0.00	5,000.00	0.00				
141 E 71200 429 000 00002 000	INSTRUCTIONAL SUP. & MAT.-ASBU	0.00	0.00	0.00	0.00	0.00	0.00				
141 E 71200 429 000 00003 000	INSTRUCTIONAL SUP. & MAT.-MIDW	0.00	0.00	0.00	0.00	0.00	0.00				
141 E 71200 429 000 00004 000	INSTRUCTIONAL SUP. & MAT.-BCES	0.00	0.00	0.00	0.00	0.00	0.00				
141 E 71200 429 000 00005 000	INSTRUCTIONAL SUP. & MAT.-BCMS	0.00	0.00	0.00	0.00	0.00	0.00				
141 E 71200 429 000 00006 000	INSTRUCTIONAL SUP. & MAT.-GVES	0.00	0.00	0.00	0.00	0.00	0.00				
141 E 71200 429 000 00007 000	INSTRUCTIONAL SUP. & MAT.-FBES	0.00	0.00	0.00	0.00	0.00	0.00				
141 E 71200 429 000 00008 000	INSTRUCTIONAL SUP. & MAT.-GES	0.00	0.00	0.00	0.00	0.00	0.00				
141 E 71200 429 000 00009 000	INSTRUCTIONAL SUP. & MAT.-JES	0.00	0.00	0.00	0.00	0.00	0.00				
141 E 71200 429 000 00010 000	INSTRUCTIONAL SUP. & MAT.-JMS	0.00	0.00	0.00	0.00	0.00	0.00				
141 E 71200 429 000 00011 000	INSTRUCTIONAL SUP. & MAT.-LES	0.00	0.00	0.00	0.00	0.00	0.00				
141 E 71200 429 000 00012 000	INSTRUCTIONAL SUP. & MAT.-SCES	0.00	0.00	0.00	0.00	0.00	0.00				
141 E 71200 429 000 00013 000	INSTRUCTIONAL SUP. & MAT.-SSES	0.00	0.00	0.00	0.00	0.00	0.00				
141 E 71200 429 000 00014 000	INSTRUCTIONAL SUP. & MAT.-WVES	0.00	0.00	0.00	0.00	0.00	0.00				
141 E 71200 429 000 00015 000	INSTRUCTIONAL SUP. & MAT.-DBHS	0.00	0.00	0.00	0.00	0.00	0.00				
141 E 71200 429 000 00016 000	INSTRUCTIONAL SUP. & MAT.-DCHS	0.00	0.00	0.00	0.00	0.00	0.00				
141 E 71200 429 000 00025 000	INSTRUCTIONAL SUP. & MAT.-RVES	0.00	0.00	0.00	0.00	0.00	0.00				
141 E 71200 499 000 00000 000	OTHER SUPPLIES AND MATERIALS	0.00	0.00	6,377.10	0.00	-6,377.10	0.00				
141 E 71200 499 000 00000 912	OTHER SUPPLIES SPED PR	0.00	0.00	0.00	0.00	0.00	0.00				
141 E 71200 595 000 00000 000	INDIVIDUALIZED EDU. ACCOUNT	0.00	0.00	0.00	0.00	0.00	0.00				
141 E 71200 599 000 00000 000	OTHER CHARGES	0.00	0.00	4,800.00	0.00	-4,800.00	0.00				

Account Level		2025-26	March 2025-26	2025-26	Encumbered	Unexpended	2025-26
Fnd T Acct	Obj Prj Loc Prg Description	Budget	Monthly Activity	FYTD Activity	Amount	Balance - YTD Act	FYTD %
71300	VOCATIONAL EDUCATION PROGRAM						
141 E 71300 730 000 00025 000	VOCATIONAL INSTR EQUIP-RVES	0.00	0.00	0.00	0.00	0.00	0.00
141 E 71300 --- --- ----- ---		5,734,673.40	425,301.52	3,032,092.57	0.00	2,702,580.83	52.87
=====							
71600	ADULT EDUCATION PROGRAM						
141 E 71600 116 000 00000 000	AD. ED. TEACHERS	0.00	0.00	0.00	0.00	0.00	0.00
141 E 71600 201 000 00000 000	SOCIAL SECURITY	0.00	0.00	0.00	0.00	0.00	0.00
141 E 71600 204 000 00000 000	STATE RETIREMENT	0.00	0.00	0.00	0.00	0.00	0.00
141 E 71600 212 000 00000 000	EMPLOYER MEDICARE	0.00	0.00	0.00	0.00	0.00	0.00
141 E 71600 429 000 00000 000	INSTRUCTIONAL SUPPLIES & MATER	0.00	0.00	0.00	0.00	0.00	0.00
141 E 71600 --- --- ----- ---		0.00	0.00	0.00	0.00	0.00	0.00
=====							
71901	COVID-19 EXP. INSTRUCTION						
141 E 71901 499 000 00000 000	OTHER CHARGES AND MATERIALS	0.00	0.00	0.00	0.00	0.00	0.00
141 E 71901 --- --- ----- ---		0.00	0.00	0.00	0.00	0.00	0.00
=====							
72110	ATTENDANCE PROGRAM						
141 E 72110 105 000 00000 000	SUPERVISOR/DIRECTOR	106,064.00	8,755.34	78,798.06	0.00	27,265.94	74.29
141 E 72110 117 000 00000 000	CAREER LADDER PROGRAM	1,000.00	0.00	0.00	0.00	1,000.00	0.00
141 E 72110 162 000 00000 000	CLERICAL PERSONNEL	46,904.00	3,842.84	34,585.56	0.00	12,318.44	73.74
141 E 72110 201 000 00000 000	SOCIAL SECURITY	9,546.00	718.18	6,599.28	0.00	2,946.72	69.13
141 E 72110 204 000 00000 000	STATE RETIREMENT	12,364.00	1,012.05	9,108.45	0.00	3,255.55	73.67
141 E 72110 206 000 00000 000	LIFE INSURANCE	50.00	4.40	30.80	0.00	19.20	61.60
141 E 72110 207 000 00000 000	MEDICAL INSURANCE	21,242.00	3,531.60	24,044.40	0.00	-2,802.40	113.19
141 E 72110 212 000 00000 000	EMPLOYER MEDICARE	2,233.00	167.96	1,543.38	0.00	689.62	69.12
141 E 72110 299 000 00000 000	OTHER FRINGE BENEFITS	0.00	0.00	0.00	0.00	0.00	0.00
141 E 72110 355 000 00000 000	TRAVEL	2,000.00	764.14	2,580.19	0.00	-580.19	129.01

Fnd T Acct	Obj Prj Loc	Prg	Account Level Description	2025-26 Budget	March 2025-26 Monthly Activity	2025-26 FYTD Activity	Encumbered Amount	Unexpended Balance - YTD Act	2025-26 FYTD %
72110 ATTENDANCE PROGRAM									
141 E 72110 499 000 00000 000			OTHER SUPPLIES AND MATERIALS	500.00	0.00	249.50	0.00	250.50	49.90
141 E 72110 499 000 00000 100			OTHER SUPPLIES & MATERIALS_D	0.00	0.00	0.00	0.00	0.00	0.00
141 E 72110 524 000 00000 000			IN-SERVICE / STAFF DEVELOPMENT	5,000.00	0.00	1,574.87	0.00	3,425.13	31.50
141 E 72110 --- --- ----- ---				206,903.00	18,796.51	159,114.49	0.00	47,788.51	76.90
72120 HEALTH SERVICES									
141 E 72120 105 000 00000 000			SUPERVISOR/DIRECTOR	0.00	20,652.00	152,037.27	0.00	-152,037.27	0.00
141 E 72120 131 000 00000 000			MEDICAL PERSONNEL	368,403.00	42,798.11	328,429.87	0.00	39,973.13	89.15
141 E 72120 131 937 00000 000			MEDICAL PERSONNEL	0.00	0.00	0.00	0.00	0.00	0.00
141 E 72120 189 000 00000 000			OTHER SALARIES & WAGES	619,098.00	11,334.97	79,702.98	0.00	539,395.02	12.87
141 E 72120 201 000 00000 000			SOCIAL SECURITY	61,225.00	4,438.74	33,400.36	0.00	27,824.64	54.55
141 E 72120 204 000 00000 000			STATE RETIREMENT	130,251.00	7,590.94	58,427.21	0.00	71,823.79	44.86
141 E 72120 206 000 00000 000			LIFE INSURANCE	450.00	44.30	310.10	0.00	139.90	68.91
141 E 72120 207 000 00000 000			MEDICAL INSURANCE	198,906.00	14,927.60	92,820.00	0.00	106,086.00	46.67
141 E 72120 212 000 00000 000			EMPLOYER MEDICARE	14,319.00	1,038.09	7,811.27	0.00	6,507.73	54.55
141 E 72120 299 000 00000 000			OTHER FRINGE BENEFITS	0.00	0.00	0.00	0.00	0.00	0.00
141 E 72120 355 000 00000 000			TRAVEL	10,000.00	1,254.12	13,342.59	0.00	-3,342.59	133.43
141 E 72120 399 000 00000 000			OTHER CONTRACTED SERVICES	5,000.00	175.00	3,611.22	0.00	1,388.78	72.22
141 E 72120 399 000 00000 100			OTHER C & S - DONATION	0.00	0.00	0.00	0.00	0.00	0.00
141 E 72120 413 000 00000 000			DRUGS AND MEDICAL SUPPLIES	0.00	0.00	0.00	0.00	0.00	0.00
141 E 72120 499 000 00000 000			OTHER SUPPLIES AND MATERIALS	31,200.00	9,495.36	22,329.40	0.00	8,870.60	71.57
141 E 72120 499 999 00000 000			OTHER SUPPLIES-DONATIONS	0.00	0.00	0.00	0.00	0.00	0.00
141 E 72120 524 000 00000 000			IN-SERVICE / STAFF DEVELOPMENT	13,000.00	0.00	4,891.92	0.00	8,108.08	37.63
141 E 72120 599 000 00000 000			OTHER CHARGES	4,000.00	610.54	6,376.09	0.00	-2,376.09	159.40
141 E 72120 --- --- ----- ---				1,455,852.00	114,359.77	803,490.28	0.00	652,361.72	55.19
72130 OTHER STUDENT SUPPORT									
141 E 72130 117 000 00000 000			CAREER LADDER PROGRAM	2,000.00	0.00	500.00	0.00	1,500.00	25.00
141 E 72130 123 000 00000 000			GUIDANCE PERSONNEL	1,386,669.00	114,288.41	775,328.51	0.00	611,340.49	55.91
141 E 72130 123 000 00000 002			CTE ISM GRANT	37,641.00	0.00	13,210.19	0.00	24,430.81	35.10

Fnd T Acct	Obj Prj Loc	Prg Description	2025-26 Budget	March 2025-26 Monthly Activity	2025-26 FYTD Activity	Encumbered Amount	Unexpended Balance - YTD Act	2025-26 FYTD %
72250		SUPPORT EDUCATION TECHNOLOGY						
141 E 72250	105 000 00000 000	TECHNOLOGY SUPERVISOR	313,324.00	22,939.05	221,344.33	0.00	91,979.67	70.64
141 E 72250	121 000 00000 000	DATA PROCESSING PERSONNEL	181,192.00	13,731.24	137,312.40	0.00	43,879.60	75.78
141 E 72250	138 000 00000 000	INSTRUCTIONAL COMPUTER PERSONN	77,803.00	6,419.42	44,935.94	0.00	32,867.06	57.76
141 E 72250	161 000 00000 000	SECRETARY	0.00	0.00	0.00	0.00	0.00	0.00
141 E 72250	189 000 00000 000	OTHER SALARIES & WAGES	417,456.00	31,217.89	307,819.70	0.00	109,636.30	73.74
141 E 72250	201 000 00000 000	SOCIAL SECURITY	61,366.00	4,390.22	42,628.08	0.00	18,737.92	69.47
141 E 72250	204 000 00000 000	STATE RETIREMENT	130,551.00	9,801.16	90,257.09	0.00	40,293.91	69.14
141 E 72250	206 000 00000 000	LIFE INSURANCE	500.00	47.90	335.30	0.00	164.70	67.06
141 E 72250	207 000 00000 000	MEDICAL INSURANCE	128,846.00	14,331.20	95,912.00	0.00	32,934.00	74.44
141 E 72250	212 000 00000 000	EMPLOYER MEDICARE	14,352.00	1,026.75	9,969.55	0.00	4,382.45	69.46
141 E 72250	299 000 00000 000	OTHER FRINGE BENEFITS	0.00	0.00	0.00	0.00	0.00	0.00
141 E 72250	350 000 00000 000	INTERNET CONNECTIVITY FEE	145,000.00	5,139.00	53,686.00	0.00	91,314.00	37.02
141 E 72250	355 000 00000 000	TRAVEL	7,000.00	590.71	6,400.47	0.00	599.53	91.44
141 E 72250	399 000 00000 000	OTHER CONTRACTED SERVICES	550,000.00	9,033.03	668,917.21	0.00	-118,917.21	121.62
141 E 72250	499 000 00000 000	OTHER SUPPLIES & MATERIALS	553,367.00	24,820.21	218,055.03	0.00	335,311.97	39.41
141 E 72250	524 440 00000 000	IN-SERVICE/STAFF DEVELOPMENT	0.00	0.00	0.00	0.00	0.00	0.00
141 E 72250	599 000 00000 000	OTHER CHARGES	0.00	0.00	0.00	0.00	0.00	0.00
141 E 72250	--- --- ----- ---		2,580,757.00	143,487.78	1,897,573.10	0.00	683,183.90	73.53
			=====	=====	=====	=====	=====	=====
72310		BOARD OF EDUCATION SERVICES						
141 E 72310	191 000 00000 000	BOARD AND COMMITTEE MEMBERS FE	41,700.00	3,475.00	31,275.00	0.00	10,425.00	75.00
141 E 72310	201 000 00000 000	SOCIAL SECURITY	2,585.00	141.16	1,428.82	0.00	1,156.18	55.27
141 E 72310	204 000 00000 000	STATE RETIREMENT	5,500.00	458.34	4,125.06	0.00	1,374.94	75.00
141 E 72310	207 000 00000 000	MEDICAL INSURANCE	66,731.00	6,626.40	41,262.00	0.00	25,469.00	61.83
141 E 72310	212 000 00000 000	EMPLOYER MEDICARE	605.00	33.01	334.19	0.00	270.81	55.24
141 E 72310	305 000 00000 000	AUDIT SERVICES	85,000.00	0.00	83,175.00	0.00	1,825.00	97.85
141 E 72310	320 000 00000 000	DUES AND MEMBERSHIPS	33,669.00	8,271.00	11,271.00	0.00	22,398.00	33.48
141 E 72310	331 000 00000 000	LEGAL SERVICES	54,000.00	4,500.00	40,500.00	0.00	13,500.00	75.00
141 E 72310	355 000 00000 000	TRAVEL	23,000.00	0.00	23,442.63	0.00	-442.63	101.92
141 E 72310	399 000 00000 000	OTHER CONTRACTED SERVICES	404,680.00	3,199.45	124,520.17	0.00	280,159.83	30.77
141 E 72310	502 000 00000 000	BUILDING & CONTENTS INSURANCE	131,000.00	0.00	579,998.00	0.00	-448,998.00	442.75
141 E 72310	506 000 00000 000	LIABILITY INSURANCE	139,600.00	0.00	84,126.00	0.00	55,474.00	60.26
141 E 72310	508 000 00000 000	PREMIUMS ON CORPORATE SURETY B	17,000.00	0.00	82,857.00	0.00	-65,857.00	487.39
141 E 72310	510 000 00000 000	TRUSTEE'S COMMISSION	680,000.00	49,063.51	475,250.21	0.00	204,749.79	69.89

Account Level		2025-26	March 2025-26	2025-26	Encumbered	Unexpended	2025-26
Fnd T Acct	Obj Prj Loc Prg Description	Budget	Monthly Activity	FYTD Activity	Amount	Balance - YTD Act	FYTD %
72310	BOARD OF EDUCATION SERVICES						
141 E 72310 513 000 00000 000	WORKER'S COMPENSATION INSURANC	300,000.00	0.00	255,013.29	0.00	44,986.71	85.00
141 E 72310 599 000 00000 000	OTHER CHARGES	0.00	1,693.99	34,592.02	0.00	-34,592.02	0.00
141 E 72310 --- --- ----- ---		1,985,070.00	77,461.86	1,873,170.39	0.00	111,899.61	94.36
		=====	=====	=====	=====	=====	=====
72320	OFFICE OF THE DIRECTOR						
141 E 72320 101 000 00000 000	DIRECTOR OF SCHOOLS	165,000.00	13,750.00	123,750.00	0.00	41,250.00	75.00
141 E 72320 117 000 00000 000	CAREER LADDER PROGRAM	1,000.00	0.00	1,500.00	0.00	-500.00	150.00
141 E 72320 127 000 00000 000	CAREER LADDER EXTENDED CONTRAC	0.00	0.00	0.00	0.00	0.00	0.00
141 E 72320 161 000 00000 000	SECRETARY(S)	378,664.00	30,840.75	306,050.28	0.00	72,613.72	80.82
141 E 72320 188 000 00000 000	BONUS	10,000.00	0.00	10,000.00	0.00	0.00	100.00
141 E 72320 189 000 00000 000	OTHER SALARIES & WAGES	49,795.00	3,763.24	37,632.40	0.00	12,162.60	75.57
141 E 72320 201 000 00000 000	SOCIAL SECURITY	37,476.00	2,762.16	28,067.72	0.00	9,408.28	74.90
141 E 72320 204 000 00000 000	STATE RETIREMENT	67,411.00	5,357.65	53,135.81	0.00	14,275.19	78.82
141 E 72320 206 000 00000 000	LIFE INSURANCE	200.00	17.40	121.80	0.00	78.20	60.90
141 E 72320 207 000 00000 000	MEDICAL INSURANCE	80,029.00	15,095.40	106,242.60	0.00	-26,213.60	132.76
141 E 72320 212 000 00000 000	EMPLOYER MEDICARE	9,308.00	645.98	6,564.04	0.00	2,743.96	70.52
141 E 72320 299 000 00000 000	OTHER FRINGE BENEFITS	0.00	0.00	0.00	0.00	0.00	0.00
141 E 72320 307 000 00000 000	COMMUNICATION	75,000.00	5,460.47	48,044.33	0.00	26,955.67	64.06
141 E 72320 348 000 00000 000	POSTAL CHARGES	14,000.00	1,974.57	9,744.33	0.00	4,255.67	69.60
141 E 72320 355 000 00000 000	TRAVEL	10,000.00	27.55	8,036.91	0.00	1,963.09	80.37
141 E 72320 399 000 00000 000	OTHER CONTRACTED SERVICES	85,000.00	2,718.42	126,778.72	0.00	-41,778.72	149.15
141 E 72320 435 000 00000 000	OFFICE SUPPLIES	5,000.00	932.80	4,496.38	0.00	503.62	89.93
141 E 72320 --- --- ----- ---		987,883.00	83,346.39	870,165.32	0.00	117,717.68	88.08
		=====	=====	=====	=====	=====	=====
72410	OFFICE OF THE PRINCIPAL						
141 E 72410 104 000 00000 000	PRINCIPALS	1,239,375.00	101,740.39	833,703.21	0.00	405,671.79	67.27
141 E 72410 117 000 00000 000	CAREER LADDER PROGRAM	25,000.00	0.00	500.00	0.00	24,500.00	2.00
141 E 72410 127 000 00000 000	CAREER LADDER EXTENDED CONTRAC	0.00	0.00	0.00	0.00	0.00	0.00
141 E 72410 139 000 00000 000	ASSISTANT PRINCIPALS	1,477,400.00	122,909.87	856,266.01	0.00	621,133.99	57.96
141 E 72410 161 000 00000 000	SECRETARY(S)	963,919.00	80,341.73	618,513.07	0.00	345,405.93	64.17

Fnd T	Acct	Obj	Prj	Loc	Prg	Account Level Description	2025-26 Budget	March 2025-26 Monthly Activity	2025-26 FYTD Activity	Encumbered Amount	Unexpended Balance - YTD Act	2025-26 FYTD %
72410						OFFICE OF THE PRINCIPAL						
141 E	72410	162	000	00000	000	SECRETARIES & BOOKKEEPERS	0.00	0.00	0.00	0.00	0.00	0.00
141 E	72410	189	000	00000	000	OTHER SALARIES & WAGES	168,799.00	14,555.43	130,531.68	0.00	38,267.32	77.33
141 E	72410	201	000	00000	000	SOCIAL SECURITY	240,219.00	18,810.96	145,048.65	0.00	95,170.35	60.38
141 E	72410	204	000	00000	000	STATE RETIREMENT	307,606.00	26,054.47	200,647.79	0.00	106,958.21	65.23
141 E	72410	206	000	00000	000	LIFE INSURANCE	1,800.00	179.50	1,256.50	0.00	543.50	69.81
141 E	72410	207	000	00000	000	MEDICAL INSURANCE	610,031.00	61,026.80	399,812.40	0.00	210,218.60	65.54
141 E	72410	212	000	00000	000	EMPLOYER MEDICARE	56,180.00	4,399.37	33,922.59	0.00	22,257.41	60.38
141 E	72410	299	000	00000	000	OTHER FRINGE BENEFITS	0.00	0.00	0.00	0.00	0.00	0.00
141 E	72410	307	000	00000	000	COMMUNICATION	25,000.00	0.00	0.00	0.00	25,000.00	0.00
141 E	72410	307	000	00002	000	COMMUNICATION-ASBURY	0.00	0.00	0.00	0.00	0.00	0.00
141 E	72410	307	000	00003	000	COMMUNICATION-MIDWAY	0.00	0.00	0.00	0.00	0.00	0.00
141 E	72410	307	000	00004	000	COMMUNICATION-BCES	0.00	0.00	0.00	0.00	0.00	0.00
141 E	72410	307	000	00005	000	COMMUNICATION-BCMS	0.00	0.00	0.00	0.00	0.00	0.00
141 E	72410	307	000	00006	000	COMMUNICATION-GVES	0.00	0.00	0.00	0.00	0.00	0.00
141 E	72410	307	000	00007	000	COMMUNICATION-FBES	0.00	0.00	0.00	0.00	0.00	0.00
141 E	72410	307	000	00008	000	COMMUNICATION-GES	0.00	0.00	0.00	0.00	0.00	0.00
141 E	72410	307	000	00009	000	COMMUNICATION-JES	0.00	0.00	0.00	0.00	0.00	0.00
141 E	72410	307	000	00010	000	COMMUNICATION-JMS	0.00	0.00	0.00	0.00	0.00	0.00
141 E	72410	307	000	00011	000	COMMUNICATION-LES	0.00	0.00	0.00	0.00	0.00	0.00
141 E	72410	307	000	00012	000	COMMUNICATION-SCES	0.00	0.00	0.00	0.00	0.00	0.00
141 E	72410	307	000	00013	000	COMMUNICATION-SSES	0.00	0.00	0.00	0.00	0.00	0.00
141 E	72410	307	000	00014	000	COMMUNICATION-WVES	0.00	0.00	0.00	0.00	0.00	0.00
141 E	72410	307	000	00015	000	COMMUNICATION-DBHS	0.00	0.00	0.00	0.00	0.00	0.00
141 E	72410	307	000	00016	000	COMMUNICATION-DCHS	0.00	0.00	0.00	0.00	0.00	0.00
141 E	72410	307	000	00025	000	COMMUNICATION-RVES	0.00	0.00	0.00	0.00	0.00	0.00
141 E	72410	355	000	00000	000	TRAVEL	7,000.00	891.75	4,428.63	0.00	2,571.37	63.27
141 E	72410	499	000	00000	000	OTHER SUPPLIES AND MATERIALS	71,500.00	0.00	0.00	0.00	71,500.00	0.00
141 E	72410	499	000	00002	000	OTHER SUPP. & MATERIALS-ASBURY	0.00	0.00	0.00	0.00	0.00	0.00
141 E	72410	499	000	00003	000	OTHER SUPP. & MATERIALS-MIDWAY	0.00	0.00	0.00	0.00	0.00	0.00
141 E	72410	499	000	00004	000	OTHER SUPP. & MATERIALS-BCES	0.00	0.00	396.96	0.00	-396.96	0.00
141 E	72410	499	000	00005	000	OTHER SUPP. & MATERIALS-BCMS	0.00	0.00	0.00	0.00	0.00	0.00
141 E	72410	499	000	00006	000	OTHER SUPP. & MATERIALS-GVES	0.00	0.00	393.23	0.00	-393.23	0.00
141 E	72410	499	000	00007	000	OTHER SUPP. & MATERIALS-FBES	0.00	0.00	394.77	0.00	-394.77	0.00
141 E	72410	499	000	00008	000	OTHER SUPP. & MATERIALS-GES	0.00	0.00	357.01	0.00	-357.01	0.00
141 E	72410	499	000	00009	000	OTHER SUPP. & MATERIALS-JES	0.00	0.00	398.41	0.00	-398.41	0.00
141 E	72410	499	000	00010	000	OTHER SUPP. & MATERIALS-JMS	0.00	0.00	0.00	0.00	0.00	0.00
141 E	72410	499	000	00011	000	OTHER SUPP. & MATERIALS-LES	0.00	0.00	427.46	0.00	-427.46	0.00
141 E	72410	499	000	00012	000	OTHER SUPP. & MATERIALS-SCES	0.00	0.00	389.08	0.00	-389.08	0.00

Account Level		2025-26	March 2025-26	2025-26	Encumbered	Unexpended	2025-26
Fnd T Acct	Obj Prj Loc Prg Description	Budget	Monthly Activity	FYTD Activity	Amount	Balance - YTD Act	FYTD %
72410	OFFICE OF THE PRINCIPAL						
141 E 72410 499 000 00013 000	OTHER SUPP. & MATERIALS-SSES	0.00	0.00	398.56	0.00	-398.56	0.00
141 E 72410 499 000 00014 000	OTHER SUPP. & MATERIALS-WVES	0.00	0.00	412.72	0.00	-412.72	0.00
141 E 72410 499 000 00015 000	OTHER SUPP. & MATERIALS-DBHS	0.00	0.00	395.40	0.00	-395.40	0.00
141 E 72410 499 000 00016 000	OTHER SUPP. & MATERIALS-DCHS	0.00	0.00	395.40	0.00	-395.40	0.00
141 E 72410 499 000 00025 000	OTHER SUPP. & MATERIALS-RVES	0.00	0.00	303.87	0.00	-303.87	0.00
141 E 72410 599 000 00000 000	OTHER CHARGES	65,000.00	0.00	65,918.75	0.00	-918.75	101.41
141 E 72410 599 000 00000 001	OTHER CHARGES-PEPSI SPONSOR	33,443.00	0.00	0.00	0.00	33,443.00	0.00
141 E 72410 599 000 00000 002	OTHER CHARGES-PEPSI SCOREBOARD	10,000.00	0.00	0.00	0.00	10,000.00	0.00
141 E 72410 599 000 00000 003	OTHER CHARGES-PEPSI SCHOLARSHI	10,000.00	0.00	0.00	0.00	10,000.00	0.00
141 E 72410 --- --- ----- ---		5,312,272.00	430,910.27	3,295,212.15	0.00	2,017,059.85	62.03
		=====	=====	=====	=====	=====	=====
72510	FISCAL SERVICES						
141 E 72510 105 000 00000 000	SUPERVISOR/DIRECTOR	269,976.00	20,650.10	206,501.00	0.00	63,475.00	76.49
141 E 72510 119 000 00000 000	ACCOUNTING STAFF	189,820.00	14,416.00	144,160.00	0.00	45,660.00	75.95
141 E 72510 162 000 00000 000	ACCOUNTING CLERK	0.00	0.00	0.00	0.00	0.00	0.00
141 E 72510 201 000 00000 000	SOCIAL SECURITY	28,507.00	2,023.96	20,720.61	0.00	7,786.39	72.69
141 E 72510 204 000 00000 000	STATE RETIREMENT	60,647.00	4,625.22	46,252.20	0.00	14,394.80	76.26
141 E 72510 206 000 00000 000	LIFE INSURANCE	100.00	6.00	42.00	0.00	58.00	42.00
141 E 72510 207 000 00000 000	MEDICAL INSURANCE	54,443.00	8,397.20	57,234.80	0.00	-2,791.80	105.13
141 E 72510 212 000 00000 000	EMPLOYER MEDICARE	6,667.00	473.34	4,846.00	0.00	1,821.00	72.69
141 E 72510 355 000 00000 000	TRAVEL	2,400.00	433.56	4,547.43	0.00	-2,147.43	189.48
141 E 72510 399 000 00000 000	OTHER CONTRACTED SERVICES	12,000.00	0.00	6,324.14	0.00	5,675.86	52.70
141 E 72510 499 000 00000 000	OTHER SUPPLIES AND MATERIALS	15,300.00	1,417.63	6,738.27	0.00	8,561.73	44.04
141 E 72510 --- --- ----- ---		639,860.00	52,443.01	497,366.45	0.00	142,493.55	77.73
		=====	=====	=====	=====	=====	=====
72520	HUMAN RESOURCES						
141 E 72520 105 000 00000 000	DIRECTOR	152,637.00	16,610.36	156,884.11	0.00	-4,247.11	102.78
141 E 72520 188 000 00000 000	BONUS	0.00	0.00	0.00	0.00	0.00	0.00
141 E 72520 189 000 00000 000	OTHER SALARIES AND WAGES	103,729.00	8,257.56	82,575.60	0.00	21,153.40	79.61
141 E 72520 201 000 00000 000	SOCIAL SECURITY	15,895.00	1,383.64	13,755.86	0.00	2,139.14	86.54

Account Level						2025-26	March 2025-26	2025-26	Encumbered	Unexpended	2025-26
Fnd T Acct	Obj Prj Loc	Prg	Description	Budget	Monthly Activity	FYTD Activity	Amount	Balance - YTD Act	FYTD %		
72520 HUMAN RESOURCES											
141 E 72520 204 000 00000 000	STATE RETIREMENT					22,489.00	2,598.69	25,454.94	0.00	-2,965.94	113.19
141 E 72520 206 000 00000 000	LIFE INSURANCE					200.00	0.00	0.00	0.00	200.00	0.00
141 E 72520 207 000 00000 000	MEDICAL INSURANCE					60,347.00	5,425.20	40,678.80	0.00	19,668.20	67.41
141 E 72520 212 000 00000 000	MEDICARE					3,717.00	323.59	3,216.99	0.00	500.01	86.55
141 E 72520 355 000 00000 000	BOARD TRAVEL					2,000.00	1,542.16	2,750.91	0.00	-750.91	137.55
141 E 72520 399 000 00000 000	OTHER CONTRACTED SERVICE					0.00	0.00	0.00	0.00	0.00	0.00
141 E 72520 499 000 00000 000	OTHER SUPPLIES AND MATERIALS					1,000.00	1,629.28	3,573.87	0.00	-2,573.87	357.39
141 E 72520 --- --- ----- ---						362,014.00	37,770.48	328,891.08	0.00	33,122.92	90.85
72610 OPERATION OF PLANT											
141 E 72610 166 000 00000 000	CUSTODIAL PERSONNEL					1,227,850.00	79,856.41	832,727.72	0.00	395,122.28	67.82
141 E 72610 189 000 00000 000	OTHER SALARIES & WAGES					330,220.00	27,884.82	275,578.53	0.00	54,641.47	83.45
141 E 72610 201 000 00000 000	SOCIAL SECURITY					96,600.00	6,284.22	66,103.83	0.00	30,496.17	68.43
141 E 72610 204 000 00000 000	STATE RETIREMENT					205,509.00	13,346.84	131,028.20	0.00	74,480.80	63.76
141 E 72610 206 000 00000 000	LIFE INSURANCE					700.00	69.50	486.50	0.00	213.50	69.50
141 E 72610 207 000 00000 000	MEDICAL INSURANCE					290,467.00	28,009.20	197,278.44	0.00	93,188.56	67.92
141 E 72610 212 000 00000 000	EMPLOYER MEDICARE					22,592.00	1,469.65	15,459.78	0.00	7,132.22	68.43
141 E 72610 328 000 00000 000	JANITORIAL SERVICES					1,776,796.00	0.00	4,564.04	0.00	1,772,231.96	0.26
141 E 72610 328 000 00002 000	JANITORIAL SERVICES-ASBURY					0.00	0.00	0.00	0.00	0.00	0.00
141 E 72610 328 000 00003 000	JANITORIAL SERVICES-MIDWAY					0.00	0.00	0.00	0.00	0.00	0.00
141 E 72610 328 000 00004 000	JANITORIAL SERVICES-BCES					0.00	17,680.24	159,122.16	0.00	-159,122.16	0.00
141 E 72610 328 000 00005 000	JANITORIAL SERVICES-BCMS					0.00	0.00	0.00	0.00	0.00	0.00
141 E 72610 328 000 00006 000	JANITORIAL SERVICES-GVES					0.00	11,512.72	103,614.48	0.00	-103,614.48	0.00
141 E 72610 328 000 00007 000	JANITORIAL SERVICES-FBES					0.00	6,578.69	59,208.21	0.00	-59,208.21	0.00
141 E 72610 328 000 00008 000	JANITORIAL SERVICES-GES					0.00	10,690.38	96,213.42	0.00	-96,213.42	0.00
141 E 72610 328 000 00009 000	JANITORIAL SERVICES-JES					0.00	17,675.35	159,078.15	0.00	-159,078.15	0.00
141 E 72610 328 000 00010 000	JANITORIAL SERVICES-JMS					0.00	0.00	0.00	0.00	0.00	0.00
141 E 72610 328 000 00011 000	JANITORIAL SERVICES-LES					0.00	9,868.03	88,812.27	0.00	-88,812.27	0.00
141 E 72610 328 000 00012 000	JANITORIAL SERVICES-SCES					0.00	7,812.21	70,309.89	0.00	-70,309.89	0.00
141 E 72610 328 000 00013 000	JANITORIAL SERVICES-SSES					0.00	8,223.37	74,010.33	0.00	-74,010.33	0.00
141 E 72610 328 000 00014 000	JANITORIAL SERVICES-WVES					0.00	7,812.21	70,309.89	0.00	-70,309.89	0.00
141 E 72610 328 000 00015 000	JANITORIAL SERVICES-DBHS					0.00	18,913.75	170,223.75	0.00	-170,223.75	0.00
141 E 72610 328 000 00016 000	JANITORIAL SERVICES-DCHS					0.00	18,913.75	170,223.75	0.00	-170,223.75	0.00
141 E 72610 328 000 00025 000	JANITORIAL SERVICES-RVES					0.00	11,512.72	103,614.48	0.00	-103,614.48	0.00

Account Level					2025-26	March 2025-26	2025-26	Encumbered	Unexpended	2025-26
Fnd T Acct	Obj Prj Loc	Prg	Description	Budget	Monthly Activity	FYTD Activity	Amount	Balance - YTD Act	FYTD %	
72610	OPERATION OF PLANT									
141 E 72610 359 000 00000 000	DISPOSAL FEES			124,000.00	11,355.67	90,192.40	0.00	33,807.60	72.74	
141 E 72610 359 000 00002 000	DISPOSAL FEES ASBURY			0.00	0.00	0.00	0.00	0.00	0.00	
141 E 72610 359 000 00003 000	DISPOSAL FEES MIDWAY			0.00	0.00	0.00	0.00	0.00	0.00	
141 E 72610 359 000 00004 000	DISPOSAL FEES BCES			0.00	0.00	0.00	0.00	0.00	0.00	
141 E 72610 359 000 00005 000	DISPOSAL FEES OLD BCMS			0.00	0.00	0.00	0.00	0.00	0.00	
141 E 72610 359 000 00006 000	DISPOSAL FEES GVES			0.00	988.33	8,009.48	0.00	-8,009.48	0.00	
141 E 72610 359 000 00007 000	DISPOSAL FEES FBES			0.00	202.50	1,552.50	0.00	-1,552.50	0.00	
141 E 72610 359 000 00008 000	DISPOSAL FEES GES			0.00	0.00	319.00	0.00	-319.00	0.00	
141 E 72610 359 000 00009 000	DISPOSAL FEES JES			0.00	750.00	6,815.00	0.00	-6,815.00	0.00	
141 E 72610 359 000 00010 000	DISPOSAL FEES JMS			0.00	0.00	220.43	0.00	-220.43	0.00	
141 E 72610 359 000 00011 000	DISPOSAL FEES LES			0.00	0.00	3,510.94	0.00	-3,510.94	0.00	
141 E 72610 359 000 00012 000	DISPOSAL FEES SCES			0.00	249.06	249.06	0.00	-249.06	0.00	
141 E 72610 359 000 00013 000	DISPOSAL FEES SSES			0.00	0.00	0.00	0.00	0.00	0.00	
141 E 72610 359 000 00014 000	DISPOSAL FEES WVES			0.00	0.00	0.00	0.00	0.00	0.00	
141 E 72610 359 000 00015 000	DISPOSAL FEES DBHS			0.00	720.18	16,970.96	0.00	-16,970.96	0.00	
141 E 72610 359 000 00016 000	DISPOSAL FEES DCHS			0.00	2,494.39	17,537.23	0.00	-17,537.23	0.00	
141 E 72610 359 000 00025 000	DISPOSAL FEES RVES			0.00	0.00	0.00	0.00	0.00	0.00	
141 E 72610 399 000 00000 000	OTHER CONTRACTED SERVICES			149,000.00	4,063.36	41,692.26	0.00	107,307.74	27.98	
141 E 72610 399 000 00002 000	OTHER CONTRACTED SERV. ASBURY			0.00	0.00	1,713.97	0.00	-1,713.97	0.00	
141 E 72610 399 000 00003 000	OTHER CONTRACTED SERV MIDWAY			0.00	0.00	1,205.00	0.00	-1,205.00	0.00	
141 E 72610 399 000 00004 000	OTHER CONTRACTED SERVICE BCES			0.00	0.00	4,707.60	0.00	-4,707.60	0.00	
141 E 72610 399 000 00005 000	OTHER CONTRACTED SERVICE BCM			0.00	0.00	0.00	0.00	0.00	0.00	
141 E 72610 399 000 00006 000	OTHER CONTRACTED SERVICE GVES			0.00	1,650.00	6,994.05	0.00	-6,994.05	0.00	
141 E 72610 399 000 00007 000	OTHER CONTRACTED SERVICE FBES			0.00	60.00	2,915.00	0.00	-2,915.00	0.00	
141 E 72610 399 000 00008 000	OTHER CONTRACTED SERVICE GES			0.00	0.00	2,236.99	0.00	-2,236.99	0.00	
141 E 72610 399 000 00009 000	OTHER CONTRACTED SERVICE JES			0.00	675.00	3,319.95	0.00	-3,319.95	0.00	
141 E 72610 399 000 00010 000	OTHER CONTRACTED SERVICE JMS			0.00	0.00	120.00	0.00	-120.00	0.00	
141 E 72610 399 000 00011 000	OTHER CONTRACTED SERVICE LES			0.00	0.00	6,341.12	0.00	-6,341.12	0.00	
141 E 72610 399 000 00012 000	OTHER CONTRACTED SERVICE SCES			0.00	100.00	4,038.86	0.00	-4,038.86	0.00	
141 E 72610 399 000 00013 000	OTHER CONTRACTED SERVICE SSES			0.00	429.99	4,259.99	0.00	-4,259.99	0.00	
141 E 72610 399 000 00014 000	OTHER CONTRACTED SERVICE WVES			0.00	0.00	6,035.98	0.00	-6,035.98	0.00	
141 E 72610 399 000 00015 000	OTHER CONTRACTED SERVICE DBHS			0.00	0.00	5,129.67	0.00	-5,129.67	0.00	
141 E 72610 399 000 00016 000	OTHER CONTRACTED SERVICE DCHS			0.00	1,680.00	19,274.28	0.00	-19,274.28	0.00	
141 E 72610 399 000 00025 000	OTHER CONTRACTED SERVICE RVES			0.00	0.00	4,981.48	0.00	-4,981.48	0.00	
141 E 72610 410 000 00000 000	CUSTODIAL SUPPLIES			136,500.00	257.10	13,130.49	0.00	123,369.51	9.62	
141 E 72610 410 000 00002 000	CUSTODIAL SUPPLIES-ASBURY			0.00	306.16	1,727.84	0.00	-1,727.84	0.00	
141 E 72610 410 000 00003 000	CUSTODIAL SUPPLIES-MIDWAY			0.00	300.74	1,277.08	0.00	-1,277.08	0.00	
141 E 72610 410 000 00004 000	CUSTODIAL SUPPLIES-BCES			0.00	1,487.11	15,004.27	0.00	-15,004.27	0.00	

Fnd T Acct	Obj Prj Loc	Prg Description	2025-26 Budget	March 2025-26 Monthly Activity	2025-26 FYTD Activity	Encumbered Amount	Unexpended Balance - YTD Act	2025-26 FYTD %
72610		OPERATION OF PLANT						
141 E 72610 434 000 00009 000		NATURAL GAS-JES	0.00	4,637.79	25,269.86	0.00	-25,269.86	0.00
141 E 72610 434 000 00010 000		NATURAL GAS-JMS	0.00	338.91	2,607.42	0.00	-2,607.42	0.00
141 E 72610 434 000 00011 000		NATURAL GAS-LES	0.00	7,248.91	19,510.85	0.00	-19,510.85	0.00
141 E 72610 434 000 00012 000		NATURAL GAS-SCES	0.00	0.00	0.00	0.00	0.00	0.00
141 E 72610 434 000 00013 000		NATURAL GAS-SSES	0.00	1,984.88	8,241.73	0.00	-8,241.73	0.00
141 E 72610 434 000 00014 000		NATURAL GAS-WVES	0.00	0.00	0.00	0.00	0.00	0.00
141 E 72610 434 000 00015 000		NATURAL GAS-DBHS	0.00	1,099.79	7,029.88	0.00	-7,029.88	0.00
141 E 72610 434 000 00016 000		NATURAL GAS-DCHS	0.00	5,780.27	37,103.90	0.00	-37,103.90	0.00
141 E 72610 434 000 00025 000		NATURAL GAS-RVES	0.00	0.00	0.00	0.00	0.00	0.00
141 E 72610 454 000 00000 000		WATER AND SEWER	266,832.00	277.65	10,863.60	0.00	255,968.40	4.07
141 E 72610 454 000 00002 000		WATER & SEWER-ASBURY	0.00	0.00	3,737.56	0.00	-3,737.56	0.00
141 E 72610 454 000 00003 000		WATER & SEWER-MIDWAY	0.00	0.00	219.95	0.00	-219.95	0.00
141 E 72610 454 000 00004 000		WATER & SEWER-BCES	0.00	5,185.64	33,725.91	0.00	-33,725.91	0.00
141 E 72610 454 000 00005 000		WATER & SEWER-BCMS	0.00	0.00	0.00	0.00	0.00	0.00
141 E 72610 454 000 00006 000		WATER & SEWER-GVES	0.00	2,362.82	13,519.66	0.00	-13,519.66	0.00
141 E 72610 454 000 00007 000		WATER & SEWER-FBES	0.00	327.62	2,848.26	0.00	-2,848.26	0.00
141 E 72610 454 000 00008 000		WATER & SEWER-GES	0.00	1,382.93	10,922.89	0.00	-10,922.89	0.00
141 E 72610 454 000 00009 000		WATER & SEWER-JES	0.00	1,123.09	9,535.92	0.00	-9,535.92	0.00
141 E 72610 454 000 00010 000		WATER & SEWER-JMS	0.00	50.13	1,305.01	0.00	-1,305.01	0.00
141 E 72610 454 000 00011 000		WATER & SEWER-LES	0.00	600.47	22,473.45	0.00	-22,473.45	0.00
141 E 72610 454 000 00012 000		WATER & SEWER-SCES	0.00	356.82	3,271.52	0.00	-3,271.52	0.00
141 E 72610 454 000 00013 000		WATER & SEWER-SSES	0.00	617.77	7,000.95	0.00	-7,000.95	0.00
141 E 72610 454 000 00014 000		WATER & SEWER-WVES	0.00	669.15	7,078.55	0.00	-7,078.55	0.00
141 E 72610 454 000 00015 000		WATER & SEWER-DBHS	0.00	4,788.05	32,919.21	0.00	-32,919.21	0.00
141 E 72610 454 000 00016 000		WATER & SEWER-DCHS	0.00	1,907.95	21,395.92	0.00	-21,395.92	0.00
141 E 72610 454 000 00025 000		WATER & SEWER-RVES	0.00	1,375.28	13,023.72	0.00	-13,023.72	0.00
141 E 72610 499 000 00000 000		OTHER SUPPLIES AND MATERIALS	96,289.00	5,704.96	92,521.10	0.00	3,767.90	96.09
141 E 72610 499 000 00000 020		TAEP -AGRICULTURAL GRANT	0.00	0.00	0.00	0.00	0.00	0.00
141 E 72610 501 000 00000 000		BOILER INSURANCE	21,000.00	0.00	14,881.00	0.00	6,119.00	70.86
141 E 72610 599 000 00000 000		OTHER CHARGES	39,900.00	2,815.94	27,197.26	0.00	12,702.74	68.16
141 E 72610 599 000 00002 000		OTHER CHARGES ASBURY	0.00	404.64	3,296.97	0.00	-3,296.97	0.00
141 E 72610 599 000 00003 000		OTHER CHARGES MIDWAY	0.00	116.00	1,034.04	0.00	-1,034.04	0.00
141 E 72610 599 000 00004 000		OTHER CHARGES BCES	0.00	290.92	2,250.11	0.00	-2,250.11	0.00
141 E 72610 599 000 00005 000		OTHER CHARGES BCMS	0.00	0.00	0.00	0.00	0.00	0.00
141 E 72610 599 000 00006 000		OTHER CHARGES GVES	0.00	0.00	0.00	0.00	0.00	0.00
141 E 72610 599 000 00007 000		OTHER CHARGES FBES	0.00	0.00	0.00	0.00	0.00	0.00
141 E 72610 599 000 00008 000		OTHER CHARGES GES	0.00	0.00	0.00	0.00	0.00	0.00
141 E 72610 599 000 00009 000		OTHER CHARGES JES	0.00	0.00	4,160.03	0.00	-4,160.03	0.00

Account Level		2025-26	March 2025-26	2025-26	Encumbered	Unexpended	2025-26
Fnd T Acct	Obj Prj Loc Prg Description	Budget	Monthly Activity	FYTD Activity	Amount	Balance - YTD Act	FYTD %
72610	OPERATION OF PLANT						
141 E 72610 599 000 00010 000	OTHER CHARGES JMS	0.00	0.00	0.00	0.00	0.00	0.00
141 E 72610 599 000 00011 000	OTHER CHARGES LES	0.00	0.00	0.00	0.00	0.00	0.00
141 E 72610 599 000 00012 000	OTHER CHARGES SCES	0.00	0.00	0.00	0.00	0.00	0.00
141 E 72610 599 000 00013 000	OTHER CHARGES SSES	0.00	0.00	437.88	0.00	-437.88	0.00
141 E 72610 599 000 00014 000	OTHER CHARGES WVES	0.00	130.60	968.97	0.00	-968.97	0.00
141 E 72610 599 000 00015 000	OTHER CHARGES DBHS	0.00	804.68	7,605.56	0.00	-7,605.56	0.00
141 E 72610 599 000 00016 000	OTHER CHARGES DCHS	0.00	0.00	0.00	0.00	0.00	0.00
141 E 72610 599 000 00025 000	OTHER CHARGES RVES	0.00	0.00	55.00	0.00	-55.00	0.00
141 E 72610 --- --- ----- ---		6,843,360.00	585,554.75	5,262,923.29	0.00	1,580,436.71	76.91
		=====	=====	=====	=====	=====	=====
72620	MAINTENANCE OF PLANT						
141 E 72620 105 000 00000 000	SUPERVISOR/DIRECTOR	294,769.00	22,412.80	224,128.00	0.00	70,641.00	76.04
141 E 72620 167 000 00000 000	MAINTENANCE PERSONNEL	1,008,735.00	71,846.66	721,319.95	0.00	287,415.05	71.51
141 E 72620 201 000 00000 000	SOCIAL SECURITY	80,817.00	5,544.70	56,527.15	0.00	24,289.85	69.94
141 E 72620 204 000 00000 000	STATE RETIREMENT	171,932.00	12,432.81	117,717.98	0.00	54,214.02	68.47
141 E 72620 206 000 00000 000	LIFE INSURANCE	300.00	28.10	196.70	0.00	103.30	65.57
141 E 72620 207 000 00000 000	MEDICAL INSURANCE	161,677.00	26,074.40	168,310.40	0.00	-6,633.40	104.10
141 E 72620 212 000 00000 000	EMPLOYER MEDICARE	18,901.00	1,296.75	13,220.01	0.00	5,680.99	69.94
141 E 72620 304 000 00000 000	ARCHITECTS	0.00	0.00	0.00	0.00	0.00	0.00
141 E 72620 307 000 00000 000	COMMUNICATION	2,700.00	107.39	997.27	0.00	1,702.73	36.94
141 E 72620 335 000 00000 000	MAINTENANCE & REPAIR - BUILDIN	226,191.00	0.00	636.00	0.00	225,555.00	0.28
141 E 72620 335 000 00002 000	MAINT. & REPAIR BUILD. ASBURY	0.00	0.00	0.00	0.00	0.00	0.00
141 E 72620 335 000 00003 000	MAINT. & REPAIR BUILD. MIDWAY	0.00	0.00	0.00	0.00	0.00	0.00
141 E 72620 335 000 00004 000	MAINT. & REPAIR BUILD. BCES	0.00	7,335.00	7,335.00	0.00	-7,335.00	0.00
141 E 72620 335 000 00005 000	MAINT. & REPAIR BUILD. BCMS	0.00	0.00	0.00	0.00	0.00	0.00
141 E 72620 335 000 00006 000	MAINT. & REPAIR BUILD. GVES	0.00	0.00	4,263.00	0.00	-4,263.00	0.00
141 E 72620 335 000 00007 000	MAINT. & REPAIR BUILD. FBES	0.00	4,116.00	4,116.00	0.00	-4,116.00	0.00
141 E 72620 335 000 00008 000	MAINT. & REPAIR BUILD. GES	0.00	0.00	3,859.50	0.00	-3,859.50	0.00
141 E 72620 335 000 00009 000	MAINT. & REPAIR BUILD. JES	0.00	0.00	0.00	0.00	0.00	0.00
141 E 72620 335 000 00010 000	MAINT. & REPAIR BUILD. JMS	0.00	0.00	0.00	0.00	0.00	0.00
141 E 72620 335 000 00011 000	MAINT. & REPAIR BUILD. LES	0.00	0.00	13,125.14	0.00	-13,125.14	0.00
141 E 72620 335 000 00012 000	MAINT. & REPAIR BUILD. SCES	0.00	0.00	4,116.00	0.00	-4,116.00	0.00
141 E 72620 335 000 00013 000	MAINT. & REPAIR BUILD. SSES	0.00	20,260.40	34,787.40	0.00	-34,787.40	0.00
141 E 72620 335 000 00014 000	MAINT. & REPAIR BUILD. WVES	0.00	0.00	4,116.00	0.00	-4,116.00	0.00

Fnd T	Acct	Obj	Prj	Loc	Prg	Account Level Description	2025-26 Budget	March 2025-26 Monthly Activity	2025-26 FYTD Activity	Encumbered Amount	Unexpended Balance - YTD Act	2025-26 FYTD %
72620						MAINTENANCE OF PLANT						
141 E	72620	499	000	00025	000	OTHER SUPPLIES & MAT. RVES	0.00	0.00	0.00	0.00	0.00	0.00
141 E	72620	599	000	00000	000	OTHER CHARGES	28,418.00	12,056.73	47,241.30	0.00	-18,823.30	166.24
141 E	72620	701	000	00000	000	ADMINISTRATION EQUIPMENT	0.00	0.00	0.00	0.00	0.00	0.00
141 E	72620	701	000	00000	004	PUBLIC SCHOOL SECURITY GRANT	0.00	0.00	0.00	0.00	0.00	0.00
141 E	72620	790	000	00000	004	OTHER EQUIPMENT	20,000.00	0.00	19,620.00	0.00	380.00	98.10
141 E	72620	---	---	-----	---		3,048,003.00	285,177.69	2,226,507.64	0.00	821,495.36	73.05
							=====	=====	=====	=====	=====	=====
72710						STUDENT TRANSPORTATION						
141 E	72710	105	000	00000	000	SUPERVISOR/DIRECTOR	147,479.00	11,201.54	112,015.40	0.00	35,463.60	75.95
141 E	72710	142	000	00000	000	MECHANIC(S)	254,051.00	19,492.56	193,094.31	0.00	60,956.69	76.01
141 E	72710	146	000	00000	000	BUS DRIVERS	1,579,575.00	145,217.65	1,074,015.73	0.00	505,559.27	67.99
141 E	72710	146	000	00000	002	CTE ISM GRANT	6,276.00	376.25	376.25	0.00	5,899.75	6.00
141 E	72710	189	000	00000	000	OTHER PERSONEL	49,795.00	3,761.62	37,616.20	0.00	12,178.80	75.54
141 E	72710	201	000	00000	000	SOCIAL SECURITY	126,305.00	10,502.46	83,122.15	0.00	43,182.85	65.81
141 E	72710	201	000	00000	002	SS-ISM GRANT	0.00	0.00	0.00	0.00	0.00	0.00
141 E	72710	204	000	00000	000	STATE RETIREMENT	262,136.00	22,725.48	177,191.35	0.00	84,944.65	67.60
141 E	72710	204	000	00000	002	STATE RETIREMENT ISM	0.00	0.00	0.00	0.00	0.00	0.00
141 E	72710	206	000	00000	000	LIFE INSURANCE	1,550.00	151.70	1,061.90	0.00	488.10	68.51
141 E	72710	207	000	00000	000	MEDICAL INSURANCE	548,362.00	52,652.60	353,537.80	0.00	194,824.20	64.47
141 E	72710	212	000	00000	000	EMPLOYER MEDICARE	28,817.00	2,486.59	19,803.22	0.00	9,013.78	68.72
141 E	72710	212	000	00000	002	MEDICARE -ISM	0.00	0.00	0.00	0.00	0.00	0.00
141 E	72710	307	000	00000	000	COMMUNICATION	750.00	19.14	473.91	0.00	276.09	63.19
141 E	72710	330	000	00000	000	OPERATING LEASE PAYMENTS	73,400.00	27,724.13	64,570.03	0.00	8,829.97	87.97
141 E	72710	338	000	00000	000	MAINTENANCE & REPAIR	0.00	0.00	0.00	0.00	0.00	0.00
141 E	72710	399	000	00000	000	OTHER CONTRACTED SERVICES	5,000.00	120.28	4,422.37	0.00	577.63	88.45
141 E	72710	412	000	00000	000	DIESEL FUEL	283,000.00	16,824.25	143,301.16	0.00	139,698.84	50.64
141 E	72710	412	000	00000	002	CTE ISM GRANT	0.00	0.00	0.00	0.00	0.00	0.00
141 E	72710	424	000	00000	000	GARAGE SUPPLIES	30,000.00	2,103.76	7,777.76	0.00	22,222.24	25.93
141 E	72710	425	000	00000	000	GASOLINE	171,867.00	9,762.29	110,620.97	0.00	61,246.03	64.36
141 E	72710	425	000	00000	002	CTE ISM GRANT	4,867.00	126.00	126.00	0.00	4,741.00	2.59
141 E	72710	442	000	00000	000	PROPANE GAS-VEHICLES	80,000.00	7,722.79	65,274.64	0.00	14,725.36	81.59
141 E	72710	450	000	00000	000	TIRES AND TUBES	60,000.00	8,179.38	24,181.71	0.00	35,818.29	40.30
141 E	72710	453	000	00000	000	VEHICLE PARTS	160,000.00	7,577.60	111,769.58	0.00	48,230.42	69.86
141 E	72710	499	000	00000	000	OTHER SUPPLIES AND MATERIALS	5,250.00	570.95	7,271.34	0.00	-2,021.34	138.50

Account Level		2025-26	March 2025-26	2025-26	Encumbered	Unexpended	2025-26
Fnd T Acct	Obj Prj Loc Prg Description	Budget	Monthly Activity	FYTD Activity	Amount	Balance - YTD Act	FYTD %
73100	FOOD SERVICE						
141 E 73100 299 000 00000 000	OTHER FRINGE BENEFITS	0.00	0.00	0.00	0.00	0.00	0.00
141 E 73100 --- --- ----- ---		0.00	0.00	0.00	0.00	0.00	0.00
=====							
73300	COMMUNITY SERVICES						
141 E 73300 105 000 00000 000	SUPERVISOR/DIRECTOR	84,957.00	6,347.90	61,974.00	0.00	22,983.00	72.95
141 E 73300 116 000 00000 000	TEACHERS	28,545.00	1,848.00	17,259.00	0.00	11,286.00	60.46
141 E 73300 161 000 00000 000	SECRETARY(S)	0.00	0.00	0.00	0.00	0.00	0.00
141 E 73300 162 000 00000 000	SECRETARY	45,448.00	3,486.29	35,023.23	0.00	10,424.77	77.06
141 E 73300 163 000 00000 000	EDUCATIONAL ASSISTANTS	1,460.00	90.00	720.00	0.00	740.00	49.32
141 E 73300 169 000 00000 000	PART-TIME PERSONNEL	0.00	0.00	0.00	0.00	0.00	0.00
141 E 73300 189 000 00000 000	OTHER SALARIES & WAGES	454,784.00	31,827.69	318,772.89	0.00	136,011.11	70.09
141 E 73300 189 000 00100 000	BCES CHILDCARE ANNEX SALARIES	0.00	0.00	0.00	0.00	0.00	0.00
141 E 73300 201 000 00000 000	SOCIAL SECURITY	38,142.00	2,604.93	26,169.43	0.00	11,972.57	68.61
141 E 73300 201 000 00100 000		0.00	0.00	0.00	0.00	0.00	0.00
141 E 73300 204 000 00000 000	STATE RETIREMENT	79,026.00	2,510.00	27,499.18	0.00	51,526.82	34.80
141 E 73300 207 000 00000 000	MEDICAL INSURANCE	27,852.00	2,622.00	17,850.00	0.00	10,002.00	64.09
141 E 73300 212 000 00000 000	EMPLOYER MEDICARE	7,275.00	609.23	6,120.29	0.00	1,154.71	84.13
141 E 73300 212 000 00100 000		0.00	0.00	0.00	0.00	0.00	0.00
141 E 73300 299 000 00000 000	OTHER FRINGE BENEFITS	20.00	0.00	0.00	0.00	20.00	0.00
141 E 73300 355 000 00000 000	TRAVEL	2,000.00	91.36	718.56	0.00	1,281.44	35.93
141 E 73300 399 000 00000 000	OTHER CONTRACTED SERVICE	1,037.00	0.00	0.00	0.00	1,037.00	0.00
141 E 73300 422 000 00000 000	FOOD SUPPLIES	30,500.00	0.00	0.00	0.00	30,500.00	0.00
141 E 73300 429 000 00000 100	OTHER SUPPLIES & MAT_LOT GRANT	4,519.00	0.00	736.04	0.00	3,782.96	16.29
141 E 73300 499 000 00000 000	OTHER SUPPLIES AND MATERIALS	20,000.00	0.00	11,465.68	0.00	8,534.32	57.33
141 E 73300 524 000 00000 100	IN-SERVICE/STAFF DEV. - LOT GR	664.00	0.00	650.46	0.00	13.54	97.96
141 E 73300 599 000 00000 000	OTHER CHARGES	13,723.00	116.01	567.97	0.00	13,155.03	4.14
141 E 73300 599 000 00000 100	OTHER CHARGES_LOT GRANT	0.00	0.00	0.00	0.00	0.00	0.00
141 E 73300 --- --- ----- ---		839,952.00	52,153.41	525,526.73	0.00	314,425.27	62.57
=====							

Account Level		2025-26	March 2025-26	2025-26	Encumbered	Unexpended	2025-26
Fnd T	Acct Obj Prj Loc Prg Description	Budget	Monthly Activity	FYTD Activity	Amount	Balance - YTD Act	FYTD %
76100	REGULAR CAPITAL OUTLAY						
141 E 76100 790 000 00000 000	OTHER EQUIPMENT	0.00	0.00	0.00	0.00	0.00	0.00
141 E 76100 799 000 00000 000	OTHER CAPITAL OUTLAY	0.00	0.00	0.00	0.00	0.00	0.00
141 E 76100 --- --- --- ---		799,844.00	44,500.00	97,198.51	0.00	702,645.49	12.15
		=====	=====	=====	=====	=====	=====
99100	TRANSFERS						
141 E 99100 316 000 00000 000	CONTRIBUTIONS TO DS	0.00	0.00	0.00	0.00	0.00	0.00
141 E 99100 590 000 00000 000	TRANSFERS TO OTHER FUNDS	350,000.00	28,241.00	282,410.00	0.00	67,590.00	80.69
141 E 99100 --- --- --- ---		350,000.00	28,241.00	282,410.00	0.00	67,590.00	80.69
		=====	=====	=====	=====	=====	=====
141 - --- --- --- ---		103,092,364.15	8,344,284.23	65,768,266.57	0.00	37,324,097.58	63.80

Number of Accounts: 821

***** End of report *****

Acct	Obj	Prj	Loc	Prg	Description	Amount
A Asset						
11140	000	000	00000	000	CASH WITH TRUSTEE D.	49,063.51CR
11140	000	000	99141	141	CASH WITH TRUSTEE	30,176,539.51
11140	000	000	99142	142		0.00
11140	000	001	99141	141		0.00
11140	000	003	99141	141		0.00
11140	000	100	99141	141		0.00
11140	000	995	99141	141		1,034.77CR
11300	000	000	00000	000	INVESTMENTS	0.00
11410	000	000	00000	000	ACCOUNTS RECEIVABLE	0.00
11420	000	000	00000	000	Allowance for Doubtful Accts.	0.00
11430	000	000	00000	000	DUE FROM OTHER GOVERNMENTS	3,727,341.36
11430	000	160	00000	000	DUE FROM OTHER GOVERNMENTS	0.00
11440	000	000	00000	000	DUE FROM OTHER FUNDS	0.00
11500	000	000	00000	000	PROPERTY TAX RECEIVABLE	14,737,383.00
11510	000	000	00000	000	ALLOWANCE FOR UNCOLL. PROPERTY	277,394.00CR
11600	000	000	00000	000	PRE-PAID ITEMS	0.00
11820	000	000	10000	602	CASH SHORTAGE	0.00
11890	000	000	00000	000	OTHER CURRENT ASSETS	0.00
-----						48,313,771.59
						=====

L Liability						
21100	000	000	00000	000	ACCOUNTS PAYABLE	668,267.58CR
21100	000	001	00000	000		0.00
21100	000	100	00000	000		0.00
21100	000	995	00000	000		0.00
21200	000	000	00000	000	ACCRUED PAYROLL	0.00
21300	000	000	00000	000	PAYROLL ADJUSTMENTS	0.00
21310	000	000	00000	000	INCOME TAX WITHHELD AND UNPAID	0.00
21310	000	003	00000	000		0.00
21310	000	995	00000	000		0.00
21320	000	000	00000	000	SOCIAL SECURITY TAX	8.76
21320	000	003	00000	000		0.00
21320	000	995	00000	000		0.00
21325	000	000	00000	000	EMPLOYEE MEDICARE DEDUCTION	32.50
21325	000	003	00000	000		0.00
21325	000	995	00000	000		30.46CR
21330	000	000	00000	000	RETIREMENT CONTRIBUTIONS	851,967.45CR
21330	000	003	00000	000		0.00
21330	000	995	00000	000		0.00
21331	000	000	00000	000	HYBRID EMPLOYER CONTRIBUTION	0.00
21339	000	000	00000	000	STATE DENTAL PLAN	29,100.97CR
21340	000	000	00000	000	MEDICAL INSURANCE CONTRIBUTION	1,340,104.43CR
21341	000	000	00000	000	COLONIAL LIFE INS PAYABLE	0.00
21342	000	000	00000	000	HARTFORD ROTH	0.00
21342	201	000	00000	000	SOCIAL SECURITY	0.00
21342	204	000	00000	000	STATE RETIREMENT	0.00
21342	207	000	00000	000	MEDICAL INSURANCE	0.00
21342	212	000	00000	000	MEDICARE	0.00
21343	000	000	00000	000	AMERICAN FAMILY LIFE PAYABLE	1,652.05
21344	000	000	00000	000	HORACE MANN LIFE INS PAYABLE	0.00
21345	000	000	00000	000	CITIZENS SECURITY DENTAL	0.00

Acct	Obj	Prj	Loc	Prg	Description	Amount
L Liability						
21346	000	000	00000	000	WASHINGTON NATIONAL INS CO	0.00
21347	000	000	00000	000	LIBERTY NATIONAL INS PAYABLE	0.00
21348	000	000	00000	000	MEDICAL INSURANCE PAYABLE	18,353.53
21349	000	000	00000	000	UNITED WAY	0.00
21350	000	000	00000	000	NTA LIFE BUSINESS SERVICES	0.00
21351	000	000	00000	000	HORACE MANN ANNUITY PAYABLE	50.00
21352	000	000	00000	000	TRANSAMERICA	0.00
21353	000	000	00000	000	DAVIS VISION	21,430.16CR
21354	000	000	00000	000	ONE AMERICA	76.08
21355	000	000	00000	000	EDUCATIONAL PLANNING GROUP	0.00
21356	000	000	00000	000	TRUSTMARK	54.44CR
21357	000	000	00000	000	MODERN WOODMEN INS PAYABLE	0.00
21358	000	000	00000	000	HYBRID-TAXED CONTRIBUTION	15,544.76
21359	000	000	00000	000	HYBRID PRETAXED CONTRIBUTION	54,042.11
21360	000	000	00000	000	GARNISHMENTS AND LEVIES	21,840.89
21361	000	000	00000	000	CENTRAL STATES HEALTH & LIFE C	0.00
21362	000	000	00000	000	USABLE LIFE	0.00
21362	201	000	00000	000	SOCIAL SECURITY	0.00
21362	204	000	00000	000	STATE RETIREMENT	0.00
21362	207	000	00000	000	MEDICAL INSURANCE	0.00
21362	212	000	00000	000	MEDICARE	0.00
21363	000	000	00000	000	MISCELLANEOUS DEDUCTIONS	0.00
21364	000	000	00000	000	LEGAL SHIELD	0.00
21365	000	000	00000	000	WAGWORKS	365.00
21365	000	440	00000	000	WAGWORKS	0.00
21366	000	000	00000	000	VALU TEACHERS	0.00
21367	000	000	00000	000	LIFE INSURANCE OF ALABAMA	0.00
21370	000	000	00000	000	AIG RETIREMENT (VALIC)	0.00
21380	000	000	00000	000	CREDIT UNION DEDUCTIONS	0.00
21390	000	000	00000	000	NEA TEA WCEA DUES	0.00
21392	000	000	00000	000	OTHER P/R DED.-MED PUT PLUS	0.00
21500	000	000	00000	000	DUE TO OTHER FUNDS	0.00
21510	000	000	00000	000	DUE TO PRIMARY GOVERNMENT	0.00
21600	000	000	00000	000	DUE TO GENERAL GOVERNMENT	0.00
21900	000	000	00000	000	DUE TO PTO	0.00
21900	000	003	00000	000		0.00
21900	000	995	00000	000		0.00
29940	000	000	00000	000	DEFERRED CURRENT PROP. TAXES	14,107,442.00CR
29945	000	000	00000	000	DEF. DELINQUENT PROPERTY TAXES	331,549.00CR
-----						17,237,980.81CR
						=====

Q Equity						
34110	000	000	00000	000	PURCHASE ORDERS PAYABLE	0.00
34111	000	000	00000	000	RESERVE FOR ENCUMBRANCE	0.00
34120	000	000	00000	000	ENCUMBRANCE PRIOR YEAR	0.00
34240	000	000	00000	000	PRE-PAID ITEMS	0.00
34555	000	000	00000	000	RESTRICTED FOR EDUCATION	51,619.00CR
34560	000	000	00000	000	RESTRICTED FOR EDUCATION - CL	1,284.70CR
34587	000	000	00000	000	RESTRCT FOR HYBRID RETIR SRT	922,238.00CR
34755	000	000	00000	000	ASSIGNED FOR EDUCATION - NISWO	0.00
34760	000	000	00000	000	ASSIGNED FOR INSTRUCTION - RET	0.00

Account Level						Amount
Acct	Obj	Prj	Loc	Prg	Description	
Q					Equity	
34765	000	000	00000	000	ASSIGNED FOR SUPPORT SERVICES	6,069,342.00CR
34770	000	000	00000	000	ASSIGNED FOR OPERATION NON-INS	0.00
34775	000	000	00000	000	ASSIGNED FOR CAPITAL OUTLAY	0.00
34780	000	000	00000	000	ASSIGNED FOR EDUCATION - CASH	3,015,000.00CR
39000	000	000	00000	000	REV EXP SUMMARY FLOW THROUGH	21,017,372.31CR
39000	000	001	00000	000		0.00
39000	000	003	00000	000		0.00
39000	000	100	00000	000		0.00
39000	000	995	00000	000		1,065.23
39999	000	000	00000	000	UNDESIGNATED FUND BALANCE	0.00
-----						31,075,790.78CR
						=====

Grand Asset Totals	48,313,771.59
Grand Liability Totals	17,237,980.81CR
Grand Equity Totals	31,075,790.78CR
Grand Totals	0.00

Number of Accounts: 106

***** End of report *****

CHECK CHECK							
<u>FND</u>	<u>ACCT</u>	<u>OBJ</u>	<u>PRJ</u>	<u>NUMBER</u>	<u>DATE</u>	<u>VENDOR</u>	<u>AMOUNT</u>
142	72220	524	900	142236208	03/06/2026	BANKCARD	110.00
142	72220	524	900	142236208	03/06/2026	BANKCARD	110.00
142	72220	524	900	142236208	03/06/2026	BANKCARD	110.00
142	72220	524	900	142236208	03/06/2026	BANKCARD	110.00
142	72220	524	900	142236208	03/06/2026	BANKCARD	110.00
142	71200	725	900	142236209	03/06/2026	CDW GOVERNMENT, INC	952.08
142	72210	355	010	142236210	03/06/2026	LADY BROYLES, LISA	36.25
142	71300	499	800	142236211	03/06/2026	NCCER	200.00
142	71200	429	900	142236212	03/06/2026	NWEA	6,075.00
142	72210	355	010	142236213	03/06/2026	WHITAKER, JERRY	211.70
142	71100	429	100	142236287	03/12/2026	BANKCARD	155.76
142	71100	429	100	142236287	03/12/2026	BANKCARD	47.76
142	72220	524	896	142236287	03/12/2026	BANKCARD	159.98
142	72130	599	800	142236288	03/12/2026	DBHS FFA	1,198.00
142	72210	524	160	142236369	03/19/2026	HOLDER, HANNAH	412.90
142	72210	524	160	142236370	03/19/2026	RAMSEY, AUNDREA	120.00
142	72130	499	100	142236386	03/25/2026	AMAZON CAPITAL SERVI	393.72
142	72220	790	900	142236386	03/25/2026	AMAZON CAPITAL SERVI	431.19
142	72130	499	100	142236386	03/25/2026	AMAZON CAPITAL SERVI	19.98
142	72130	499	100	142236386	03/25/2026	AMAZON CAPITAL SERVI	322.30
142	72130	499	100	142236391	03/25/2026	SILVER INK PUBLISHIN	579.90
142	72210	499	010	142236451	03/27/2026	WASHINGTON CO DEPT O	345.80
Totals for checks							12,212.32

Sped Classroom Materials

FUND SUMMARY

<u>FUND</u>	<u>DESCRIPTION</u>	<u>BALANCE SHEET</u>	<u>REVENUE</u>	<u>EXPENSE</u>	<u>TOTAL</u>
142	SCHOOL FEDERAL PROJECTS	0.00	0.00	12,212.32	12,212.32
***	Fund Summary Totals ***	0.00	0.00	12,212.32	12,212.32

***** End of report *****

Account Level		2025-26	March 2025-26	2025-26	Encumbered	Unexpended	2025-26
Fnd T Acct	Obj Prj Loc Prg Description	Budget	Monthly Activity	FYTD Activity	Amount	Balance - YTD Act	FYTD %
010	CONSOLIDATED ADMINISTRATION						
142 E 72210 105 010 00001 000	SUPERVISOR/DIRECTOR	55,100.00	0.00	0.00	0.00	55,100.00	0.00
142 E 72210 162 010 00001 000	CLERICAL PERSONNEL	62,748.00	4,648.00	46,480.00	0.00	16,268.00	74.07
142 E 72210 189 010 00000 000	OTHER SALARIES & WAGES	47,397.24	0.00	0.00	0.00	47,397.24	0.00
142 E 72210 201 010 00000 000		7,306.58	0.00	0.00	0.00	7,306.58	0.00
142 E 72210 201 010 00001 000	SOCIAL SECURITY	0.00	288.18	2,881.79	0.00	-2,881.79	0.00
142 E 72210 204 010 00000 000		11,455.73	0.00	0.00	0.00	11,455.73	0.00
142 E 72210 204 010 00001 000	STATE RETIREMENT	0.00	613.08	6,130.79	0.00	-6,130.79	0.00
142 E 72210 207 010 00000 000		9,468.00	0.00	0.00	0.00	9,468.00	0.00
142 E 72210 212 010 00000 000		2,524.45	0.00	0.00	0.00	2,524.45	0.00
142 E 72210 212 010 00001 000	EMPLOYER MEDICARE	0.00	67.40	674.00	0.00	-674.00	0.00
142 E 72210 355 010 00000 000	TRAVEL	10,000.00	247.95	660.10	0.00	9,339.90	6.60
142 E 72210 499 010 00000 000	OTHER SUPPLIES AND MATERIALS	10,000.00	345.80	2,036.53	0.00	7,963.47	20.37
142 E 72210 524 010 00000 000	IN SERVICE / STAFF DEVELOPMENT	10,200.00	0.00	6,302.24	0.00	3,897.76	61.79
142 E 99100 504 010 00008 000	INDIRECT COST	2,000.00	0.00	0.00	0.00	2,000.00	0.00
	010	228,200.00	6,210.41	65,165.45	0.00	163,034.55	28.56

Fnd T	Acct	Obj	Prj	Loc	Prg	Account Level Description	2025-26 Budget	March 2025-26 Monthly Activity	2025-26 FYTD Activity	Encumbered Amount	Unexpended Balance - YTD Act	2025-26 FYTD %
100						TITLE I						
142	E	71100	116	100	00000	000 TEACHERS	905,773.00	75,481.14	528,367.98	0.00	377,405.02	58.33
142	E	71100	163	100	00000	000 EDUCATIONAL ASSISTANTS	178,627.85	12,727.04	54,030.50	0.00	124,597.35	30.25
142	E	71100	201	100	00000	000 SOCIAL SECURITY	67,232.85	5,038.19	33,263.33	0.00	33,969.52	49.47
142	E	71100	204	100	00000	000 STATE RETIREMENT	79,613.23	5,542.16	35,778.92	0.00	43,834.31	44.94
142	E	71100	207	100	00000	000 MEDICAL INSURANCE	286,188.00	24,900.40	153,804.80	0.00	132,383.20	53.74
142	E	71100	212	100	00000	000 EMPLOYER MEDICARE	15,723.81	1,178.30	7,779.37	0.00	7,944.44	49.48
142	E	71100	429	100	00000	000 INSTRUCTIONAL SUPPLIES & MATER	33,159.40	203.52	11,027.57	0.00	22,131.83	33.26
142	E	72130	189	100	00000	000 OTHER SALARIES & WAGES	9,000.00	0.00	4,455.00	0.00	4,545.00	49.50
142	E	72130	201	100	00000	000 SOCIAL SECURITY	558.00	0.00	257.25	0.00	300.75	46.10
142	E	72130	204	100	00000	000 STATE RETIREMENT	810.00	0.00	273.03	0.00	536.97	33.71
142	E	72130	212	100	00000	000 EMPLOYER MEDICARE	130.50	0.00	60.18	0.00	70.32	46.11
142	E	72130	499	100	00000	000 OTHER SUPPLIES AND MATERIALS	18,000.00	1,315.90	5,191.66	0.00	12,808.34	28.84
142	E	72130	599	100	00000	000 OTHER CHARGES	5,000.00	0.00	0.00	0.00	5,000.00	0.00
142	E	72210	189	100	00000	000 OTHER SALARIES & WAGES	29,700.00	3,118.50	14,256.00	0.00	15,444.00	48.00
142	E	72210	201	100	00000	000 SOCIAL SECURITY	1,023.00	70.62	294.39	0.00	728.61	28.78
142	E	72210	204	100	00000	000 STATE RETIREMENT	1,188.00	76.24	288.44	0.00	899.56	24.28
142	E	72210	212	100	00000	000 EMPLOYER MEDICARE	727.65	44.97	205.66	0.00	521.99	28.26
142	E	72210	524	100	00000	000 IN SERVICE / STAFF DEVELOPMENT	50,000.00	0.00	8,532.05	0.00	41,467.95	17.06
142	E	72210	599	100	00000	000 OTHER CHARGES	154,293.25	0.00	0.00	0.00	154,293.25	0.00
142	E	99100	504	100	00008	000 INDIRECT COST	10,000.00	0.00	0.00	0.00	10,000.00	0.00
			100				1,846,748.54	129,696.98	857,866.13	0.00	988,882.41	46.45

Fnd T Acct	Obj Prj Loc	Prg	Account Level Description	2025-26 Budget	March 2025-26 Monthly Activity	2025-26 FYTD Activity	Encumbered Amount	Unexpended Balance - YTD Act	2025-26 FYTD %
160			TITLE I-D						
142 E 71100 399 160 00000 000			OTHER CONTRACTED SERVICE	7,650.00	0.00	0.00	0.00	7,650.00	0.00
142 E 71100 429 160 00000 000			INSTRUCTIONAL SUPPLIES & MATER	20,378.02	0.00	10,529.98	0.00	9,848.04	51.67
142 E 71100 499 160 00000 000			OTHER SUPPLIES AND MATERIALS	18,121.40	0.00	17,966.38	0.00	155.02	99.14
142 E 71100 599 160 00000 000			OTHER CHARGES	8,000.00	0.00	0.00	0.00	8,000.00	0.00
142 E 72210 524 160 00000 000			IN-SERVICE / STAFF DEVELOPMENT	9,000.00	532.90	1,699.10	0.00	7,300.90	18.88
142 E 99100 504 160 00000 000			INDIRECT COST	500.00	0.00	0.00	0.00	500.00	0.00
	160			63,649.42	532.90	30,195.46	0.00	33,453.96	47.44

Account Level		2025-26	March 2025-26	2025-26	Encumbered	Unexpended	2025-26
Fnd T Acct	Obj Prj Loc Prg Description	Budget	Monthly Activity	FYTD Activity	Amount	Balance - YTD Act	FYTD %
200	TITLE II - A						
142 E 72210 138 200 00000 000	INSTR COMPUTER PERSONNEL	73,556.00	0.00	24,518.68	0.00	49,037.32	33.33
142 E 72210 138 200 00010 000	INSTR COMPUTER PERSONNEL	0.00	0.00	6,129.67	0.00	-6,129.67	0.00
142 E 72210 189 200 00000 000	OTHER SALARIES & WAGES	115,776.83	6,066.50	42,465.50	0.00	73,311.33	36.68
142 E 72210 201 200 00000 000	SOCIAL SECURITY	9,073.95	364.16	3,944.29	0.00	5,129.66	43.47
142 E 72210 201 200 00010 000		0.00	0.00	348.65	0.00	-348.65	0.00
142 E 72210 204 200 00000 000	STATE RETIREMENT	8,444.62	350.04	3,865.00	0.00	4,579.62	45.77
142 E 72210 204 200 00010 000		0.00	0.00	353.68	0.00	-353.68	0.00
142 E 72210 207 200 00000 000	MEDICAL INSURANCE	26,220.00	728.40	12,260.40	0.00	13,959.60	46.76
142 E 72210 207 200 00010 000		0.00	0.00	1,802.40	0.00	-1,802.40	0.00
142 E 72210 212 200 00000 000	EMPLOYER MEDICARE	2,745.33	85.17	922.47	0.00	1,822.86	33.60
142 E 72210 212 200 00010 000		0.00	0.00	81.54	0.00	-81.54	0.00
142 E 72210 524 200 00000 000	IN SERVICE / STAFF DEVELOPMENT	157,382.03	0.00	26,167.80	0.00	131,214.23	16.63
142 E 99100 504 200 00008 000	INDIRECT COST	5,000.00	0.00	0.00	0.00	5,000.00	0.00
	200	398,198.76	7,594.27	122,860.08	0.00	275,338.68	30.85

Account Level						2025-26	March 2025-26	2025-26	Encumbered	Unexpended	2025-26	
Fnd T Acct	Obj	Prj	Loc	Prg	Description	Budget	Monthly Activity	FYTD Activity	Amount	Balance - YTD Act	FYTD %	
300 TITLE III												
142 E	71100	429	300	00000	000	INSTRUCTIONAL SUPPLIES & MATER	5,928.64	0.00	0.00	0.00	5,928.64	0.00
142 E	72130	499	300	00000	000	OTHER SUPPLIES AND MATERIALS	3,000.00	0.00	0.00	0.00	3,000.00	0.00
142 E	72210	524	300	00000	000	IN SERVICE / STAFF DEVELOPMENT	4,000.00	0.00	0.00	0.00	4,000.00	0.00
300						12,928.64	0.00	0.00	0.00	12,928.64	0.00	

Fnd T Acct	Obj Prj Loc	Prg	Account Level Description	2025-26 Budget	March 2025-26 Monthly Activity	2025-26 FYTD Activity	Encumbered Amount	Unexpended Balance - YTD Act	2025-26 FYTD %
440			TITLE IV						
142 E 71150 116 440 00000 000			TEACHERS	47,410.44	0.00	0.00	0.00	47,410.44	0.00
142 E 71150 212 440 00000 000			MEDICARE	687.44	0.00	0.00	0.00	687.44	0.00
142 E 72130 123 440 00000 000			GUIDANCE PERSONNEL	59,388.20	4,813.34	33,693.38	0.00	25,694.82	56.73
142 E 72130 201 440 00000 000			SOCIAL SECURITY	3,682.06	272.03	1,908.41	0.00	1,773.65	51.83
142 E 72130 204 440 00000 000			STATE RETIREMENT	5,344.94	433.20	3,032.40	0.00	2,312.54	56.73
142 E 72130 207 440 00000 000			MEDICAL INSURANCE	16,380.00	1,638.00	11,154.00	0.00	5,226.00	68.10
142 E 72130 212 440 00000 000			EMPLOYER MEDICARE	861.14	63.62	446.30	0.00	414.84	51.83
142 E 72130 524 440 00000 000			IN SERVICE / STAFF DEVELOPMENT	2,400.00	0.00	2,337.60	0.00	62.40	97.40
142 E 72250 524 440 00000 000			IN-SERVICE / STAFF DEVELOPMENT	5,478.75	0.00	2,304.60	0.00	3,174.15	42.06
142 E 99100 504 440 00000 000			INDIRECT COST	1,000.00	0.00	0.00	0.00	1,000.00	0.00
	440			142,632.97	7,220.19	54,876.69	0.00	87,756.28	38.47

Account Level						2025-26	March 2025-26	2025-26	Encumbered	Unexpended	2025-26
Fnd T Acct	Obj Prj Loc	Prg	Description	Budget	Monthly Activity	FYTD Activity	Amount	Balance - YTD Act	FYTD %		
800 CARL PERKINS											
142 E 71300 189 800 00021 000	OTHER SALARIES & WAGES					5,329.20	0.00	0.00	0.00	5,329.20	0.00
142 E 71300 201 800 00021 000	SOCIAL SECURITY					330.41	0.00	0.00	0.00	330.41	0.00
142 E 71300 204 800 00021 000	STATE RETIREMENT					338.94	0.00	0.00	0.00	338.94	0.00
142 E 71300 207 800 00021 000	MEDICAL INSURANCE					164.40	0.00	0.00	0.00	164.40	0.00
142 E 71300 212 800 00021 000	EMPLOYER MEDICARE					77.27	0.00	0.00	0.00	77.27	0.00
142 E 71300 471 800 00000 000	SOFTWARE					62,000.00	0.00	65,822.83	0.00	-3,822.83	106.17
142 E 71300 499 800 00000 000	OTHER SUPPLIES AND MATERIALS					32,518.14	200.00	31,987.25	0.00	530.89	98.37
142 E 71300 730 800 00000 000	VOCATIONAL INSTRUCTION EQUIPME					13,000.00	0.00	8,852.64	0.00	4,147.36	68.10
142 E 72130 524 800 00000 000	IN SERVICE / STAFF DEVELOPMENT					18,300.21	0.00	12,914.60	0.00	5,385.61	70.57
142 E 72130 599 800 00000 000	OTHER CHARGES					11,000.00	1,198.00	11,592.00	0.00	-592.00	105.38
800						143,058.57	1,398.00	131,169.32	0.00	11,889.25	91.69

Account Level		2025-26	March 2025-26	2025-26	Encumbered	Unexpended	2025-26
Fnd T Acct	Obj Prj Loc Prg Description	Budget	Monthly Activity	FYTD Activity	Amount	Balance - YTD Act	FYTD %
801	CARL PERKINS RESERVE GRANT						
142 E 71300 189 801 00000 000	OTHER SALARIES AND WAGES	1,320.00	0.00	0.00	0.00	1,320.00	0.00
142 E 71300 429 801 00000 000	INSTRUCTIONAL SUPPLIES & MATRI	16,900.00	0.00	0.00	0.00	16,900.00	0.00
142 E 71300 499 801 00000 000	OTHER SUPPLIES AND MATERIALS	24,180.00	0.00	0.00	0.00	24,180.00	0.00
142 E 71300 730 801 00000 000	VOCATIONAL INSTRUCTION EQUIP	7,600.00	0.00	0.00	0.00	7,600.00	0.00
	801	50,000.00	0.00	0.00	0.00	50,000.00	0.00

Account Level		2025-26	March 2025-26	2025-26	Encumbered	Unexpended	2025-26
Fnd T Acct	Obj Prj Loc Prg Description	Budget	Monthly Activity	FYTD Activity	Amount	Balance - YTD Act	FYTD %
896	IDEA PART SYSTEMIC CHANGE K-12						
142 E 71200 116 896 00000 000	TEACHERS	77,600.00	0.00	27,725.00	0.00	49,875.00	35.73
142 E 71200 195 896 00000 000	CERTIFIED SUBSTITUTE TEACHERS	1.00	0.00	0.00	0.00	1.00	0.00
142 E 71200 201 896 00000 000	SOCIAL SECURITY	4,815.00	0.00	1,704.45	0.00	3,110.55	35.40
142 E 71200 204 896 00000 000		7,760.00	0.00	1,931.14	0.00	5,828.86	24.89
142 E 71200 212 896 00000 000	MEDICARE	1,125.50	0.00	398.70	0.00	726.80	35.42
142 E 71200 299 896 00000 000	OTHER FRINGE BENEFITS	315.00	0.00	0.00	0.00	315.00	0.00
142 E 71200 429 896 00000 000	SUPPLIES & MATERIALS	2,500.00	0.00	0.00	0.00	2,500.00	0.00
142 E 72220 524 896 00000 000	IN-SERVICE / STAFF DEVELOPMENT	5,883.50	159.98	17,329.38	0.00	-11,445.88	294.54
	896	100,000.00	159.98	49,088.67	0.00	50,911.33	49.09

Account Level		2025-26	March 2025-26	2025-26	Encumbered	Unexpended	2025-26
Fnd T Acct	Obj Prj Loc Prg Description	Budget	Monthly Activity	FYTD Activity	Amount	Balance - YTD Act	FYTD %
898	IDEA PART SYSTEMIC CHANGE PRES						
142 E 71200 116 898 00000 000	TEACHERS	5,000.00	0.00	2,904.00	0.00	2,096.00	58.08
142 E 71200 201 898 00000 000	SOCIAL SECURITY	310.00	0.00	180.07	0.00	129.93	58.09
142 E 71200 204 898 00000 000	STATE RETIREMENT	625.00	0.00	259.52	0.00	365.48	41.52
142 E 71200 212 898 00000 000	MEDICARE	75.00	0.00	42.14	0.00	32.86	56.19
142 E 71200 429 898 00000 000	INSTRUCTIONAL SUPPLIES & MAT.	5,000.00	0.00	2,979.93	0.00	2,020.07	59.60
142 E 72220 524 898 00000 000	IN-SERVICE / STAFF DEVELOPMENT	5,000.00	0.00	0.00	0.00	5,000.00	0.00
	898	16,010.00	0.00	6,365.66	0.00	9,644.34	39.76

Fnd T Acct	Obj Prj Loc	Prg Description	2025-26 Budget	March 2025-26 Monthly Activity	2025-26 FYTD Activity	Encumbered Amount	Unexpended Balance - YTD Act	2025-26 FYTD %
900		IDEA PART- B						
142 E 71200 116 900 00000 000		TEACHERS	140,379.00	11,047.01	77,329.07	0.00	63,049.93	55.09
142 E 71200 163 900 00000 000		EDUCATIONAL ASSISTANTS	1,062,380.50	83,729.42	626,108.98	0.00	436,271.52	58.93
142 E 71200 171 900 00000 000		SPEECH PATHOLOGIST	100,000.00	4,852.84	33,969.88	0.00	66,030.12	33.97
142 E 71200 189 900 00000 000		OTHER SALARIES & WAGES	5,000.00	0.00	0.00	0.00	5,000.00	0.00
142 E 71200 201 900 00000 000		SOCIAL SECURITY	82,000.00	5,870.38	43,509.66	0.00	38,490.34	53.06
142 E 71200 204 900 00000 000		STATE RETIREMENT	265,000.00	11,661.69	85,862.81	0.00	179,137.19	32.40
142 E 71200 207 900 00000 000		MEDICAL INSURANCE	500,000.00	24,124.40	167,586.80	0.00	332,413.20	33.52
142 E 71200 212 900 00000 000		EMPLOYER MEDICARE	21,000.00	1,372.90	10,175.68	0.00	10,824.32	48.46
142 E 71200 312 900 00000 000		CONTRACTS W PRIVATE AGENCIES	100,000.00	0.00	100,693.60	0.00	-693.60	100.69
142 E 71200 429 900 00000 000		INSTRUCTIONAL SUPPLIES & MAT.	25,000.00	5,974.00	5,550.37	0.00	19,449.63	22.20
142 E 71200 499 900 00000 000		OTHER SUPPLIES AND MATERIALS	5,000.00	0.00	525.22	0.00	4,474.78	10.50
142 E 71200 725 900 00000 000		SPECIAL EDUCATION EQUIPMENT	20,000.00	952.08	4,224.96	0.00	15,775.04	21.12
142 E 72220 189 900 00000 000		OTHER SALARIES & WAGES	140,000.00	6,159.09	43,113.63	0.00	96,886.37	30.80
142 E 72220 201 900 00000 000		SOCIAL SECURITY	9,000.00	381.86	2,673.02	0.00	6,326.98	29.70
142 E 72220 204 900 00000 000		STATE RETIREMENT	18,000.00	554.32	3,880.22	0.00	14,119.78	21.56
142 E 72220 207 900 00000 000		MEDICAL INSURANCE	32,600.00	0.00	0.00	0.00	32,600.00	0.00
142 E 72220 212 900 00000 000		EMPLOYER MEDICARE	2,100.00	89.31	625.17	0.00	1,474.83	29.77
142 E 72220 355 900 00000 000		TRAVEL	15,000.00	0.00	0.00	0.00	15,000.00	0.00
142 E 72220 429 900 00000 000		Instructional Supplies & Mat.	0.00	101.00	0.00	0.00	0.00	0.00
142 E 72220 499 900 00000 000		OTHER SUPPLIES AND MATERIALS	10,000.00	0.00	11,768.61	0.00	-1,768.61	117.69
142 E 72220 524 900 00000 000		IN SERVICE / STAFF DEVELOPMENT	40,246.29	550.00	12,131.70	0.00	28,114.59	30.14
142 E 72220 790 900 00000 000		OTHER EQUIPMENT	5,000.00	431.19	5,431.81	0.00	-431.81	108.64
142 E 72710 146 900 00020 000		BUS DRIVERS	200,565.00	19,222.80	136,445.85	0.00	64,119.15	68.03
142 E 72710 189 900 00000 000		OTHER SALARIES AND WAGES	20,668.00	708.01	5,744.78	0.00	14,923.22	27.80
142 E 72710 201 900 00000 000			13,716.45	43.90	356.18	0.00	13,360.27	2.60
142 E 72710 201 900 00020 000		SOCIAL SECURITY	0.00	1,021.84	7,282.00	0.00	-7,282.00	0.00
142 E 72710 204 900 00020 000		STATE RETIREMENT	27,654.15	2,535.49	17,861.40	0.00	9,792.75	64.59
142 E 72710 207 900 00020 000		MEDICAL INSURANCE	100,000.00	5,461.20	37,186.80	0.00	62,813.20	37.19
142 E 72710 212 900 00000 000			3,207.90	10.27	83.29	0.00	3,124.61	2.60
142 E 72710 212 900 00020 000		EMPLOYER MEDICARE	0.00	259.20	1,844.91	0.00	-1,844.91	0.00
142 E 72710 599 900 00000 000		OTHER CHARGES	2,000.00	0.00	2,040.00	0.00	-40.00	102.00
	900		2,965,517.29	187,114.20	1,444,006.40	0.00	1,521,510.89	48.69

Account Level		2025-26	March 2025-26	2025-26	Encumbered	Unexpended	2025-26
Fnd T Acct	Obj Prj Loc Prg Description	Budget	Monthly Activity	FYTD Activity	Amount	Balance - YTD Act	FYTD %
910	IDEA PRESCHOOL						
142 E 71200 163 910 00000 000	EDUCATIONAL ASSISTANTS	92,858.00	2,796.82	20,380.02	0.00	72,477.98	21.95
142 E 71200 189 910 00000 000	OTHER SALARIES AND WAGES	5,432.37	0.00	0.00	0.00	5,432.37	0.00
142 E 71200 201 910 00000 000	SOCIAL SECURITY	4,778.00	162.43	1,187.93	0.00	3,590.07	24.86
142 E 71200 204 910 00000 000	STATE RETIREMENT	8,307.00	368.90	2,688.12	0.00	5,618.88	32.36
142 E 71200 207 910 00000 000	MEDICAL INSURANCE	21,000.00	728.40	4,959.60	0.00	16,040.40	23.62
142 E 71200 212 910 00000 000	EMPLOYER MEDICARE	1,267.00	37.99	277.83	0.00	989.17	21.93
142 E 71200 312 910 00000 000	CONTRACTS W PRIVATE AGENCIES	3,575.00	0.00	1,869.01	0.00	1,705.99	52.28
142 E 71200 429 910 00000 000	INSTRUCTIONAL SUPPLIES & MATER	9,000.00	0.00	5,690.85	0.00	3,309.15	63.23
142 E 72220 499 910 00000 000	OTHER SUPPLIES AND MATERIALS	5,000.00	0.00	2,226.93	0.00	2,773.07	44.54
142 E 72220 524 910 00000 000	IN SERVICE / STAFF DEVELOPMENT	10,000.00	0.00	0.00	0.00	10,000.00	0.00
142 E 72220 599 910 00000 000	OTHER CHARGES	920.00	0.00	0.00	0.00	920.00	0.00
	910	162,137.37	4,094.54	39,280.29	0.00	122,857.08	24.23

Account Level		2025-26	March 2025-26	2025-26	Encumbered	Unexpended	2025-26
Fnd T Acct	Obj Prj Loc Prg Description	Budget	Monthly Activity	FYTD Activity	Amount	Balance - YTD Act	FYTD %
951	HQIM-PARTICIPANT LITERACY NETW						
142 E 71100 399 951 00000 000	OTHER CONTRACTED SERVICE	72,800.00	0.00	0.00	0.00	72,800.00	0.00
142 E 71100 429 951 00000 000	SUPPLIES & MATERIALS	1,500.00	0.00	0.00	0.00	1,500.00	0.00
142 E 72210 399 951 00000 000	OTHER CONTRACTED SERVICE	0.00	0.00	36,400.00	0.00	-36,400.00	0.00
	951	74,300.00	0.00	36,400.00	0.00	37,900.00	48.99

Account Level		2025-26	March 2025-26	2025-26	Encumbered	Unexpended	2025-26
Fnd T	Acct Obj Prj Loc Prg Description	Budget	Monthly Activity	FYTD Activity	Amount	Balance - YTD Act	FYTD %
953	EARLY LITERACY PRE-K TEACHER S						
142 E 73400 189 953 00008 000	OTHER SALARIES AND WAGES	0.00	0.00	10,000.00	0.00	-10,000.00	0.00
	953	0.00	0.00	10,000.00	0.00	-10,000.00	0.00

Number of Accounts: 140

***** End of report *****

Fnd T Acct	Obj Prj Loc	Prg	Account Level Description	Amount
A			Asset	
142 A 11130	000 000 000000	000	CASH IN BANK-PAYROLL	0.00
142 A 11130	000 100 000000	000	CASH IN BANK-PAYROLL	0.00
142 A 11130	000 440 000000	000	CASH IN BANK-PAYROLL	0.00
142 A 11130	---	---	-----	0.00
142 A 11140	000 000 000000	000	CASH WITH TRUSTEE	0.00
142 A 11140	000 000 000000	142	CASH WITH TRUSTEE	0.00
142 A 11140	000 000 99141	141		787.49CR
142 A 11140	000 000 99142	142		1,490,373.14
142 A 11140	000 010 000000	142	CASH WITH TRUSTEE - CON ADMIN	0.00
142 A 11140	000 010 99141	141		0.00
142 A 11140	000 010 99142	142		3,460.67CR
142 A 11140	000 100 000000	000	CASH WITH TRUSTEE	0.00
142 A 11140	000 100 000000	142	CASH WITH TRUSTEE - TITLE I	0.00
142 A 11140	000 100 99141	141		0.00
142 A 11140	000 100 99142	142		4,884.88CR
142 A 11140	000 101 99142	142		0.00
142 A 11140	000 160 000000	000	TITLE I-D	0.00
142 A 11140	000 160 99141	141		0.00
142 A 11140	000 160 99142	142		532.90CR
142 A 11140	000 171 99142	142		0.00
142 A 11140	000 172 99142	142		0.00
142 A 11140	000 200 000000	142	CASH WITH TRUSTEE - TITLE II-A	0.00
142 A 11140	000 200 99141	141		0.00
142 A 11140	000 200 99142	142		1,612.84CR
142 A 11140	000 300 000000	142	CASH WITH TRUSTEE - TITLE III	0.00
142 A 11140	000 440 000000	141	CASH WITH TRUSTEE	0.00
142 A 11140	000 440 99141	141		33,292.83
142 A 11140	000 440 99142	142		34,098.41CR
142 A 11140	000 480 000000	142	CASH WITH TRUSTEE - FTTT DISCR	0.00
142 A 11140	000 580 000000	142	CASH WITH TRUSTEE - FTTT	0.00
142 A 11140	000 700 99142	142		0.00
142 A 11140	000 705 99142	142		0.00
142 A 11140	000 720 99142	142		0.00
142 A 11140	000 800 000000	142	CASH WITH TRUSTEE - CARL PERKI	0.00
142 A 11140	000 800 99141	141		0.00
142 A 11140	000 800 99142	142		3,922.00CR
142 A 11140	000 801 000000	142	CASH WITH TRUSTEE - CTE RESERV	0.00
142 A 11140	000 801 99142	142		0.00
142 A 11140	000 802 99142	142		0.00
142 A 11140	000 803 99142	142		0.00
142 A 11140	000 890 99142	142		229.54
142 A 11140	000 891 000000	142	CASH WITH TRUSTEE - STATE DISC	0.00
142 A 11140	000 891 99142	142		0.00
142 A 11140	000 892 000000	142	CASH WITH TRUSTEE - DISC PRESC	0.00
142 A 11140	000 892 99142	142		0.00
142 A 11140	000 893 000000	142	CASH WITH TRUSTEE - IDEA DISC	0.00
142 A 11140	000 893 99142	142		0.00
142 A 11140	000 894 000000	142	CASH WITH TRUSTEE - FS GRAY	0.00
142 A 11140	000 894 99142	142		0.00
142 A 11140	000 895 000000	142	CASH WITH TRUSTEE - FS JM	0.00
142 A 11140	000 895 99142	142		0.00
142 A 11140	000 896 000000	142	CASH WITH TRUSTEE - FS SS	0.00
142 A 11140	000 896 99142	142		51,524.02CR
142 A 11140	000 897 99142	142		0.00

Fnd T Acct	Obj Prj Loc	Prg	Account Level Description	Amount
A			Asset	
142 A 11140 000 898 99142 142				6,019.92CR
142 A 11140 000 899 99141 141				0.00
142 A 11140 000 899 99142 142				0.00
142 A 11140 000 900 00000 000			CASH WITH TRUSTEE-IDEA PART B	0.00
142 A 11140 000 900 00000 142			CASH WITH TRUSTEE-IDEA PART B	0.00
142 A 11140 000 900 99141 141				0.00
142 A 11140 000 900 99142 142				209,902.66CR
142 A 11140 000 901 00000 142			EDUCATION HANDICAPPED ACT - I	0.00
142 A 11140 000 901 99142 142				0.00
142 A 11140 000 902 00000 142			EDUCATION HANDICAPPED ACT - ID	0.00
142 A 11140 000 910 00000 142			CASH WITH TRUSTEE - IDEA PRESC	0.00
142 A 11140 000 910 99141 141				0.00
142 A 11140 000 910 99142 142				11,787.90CR
142 A 11140 000 911 99142 142				0.00
142 A 11140 000 912 99142 142				0.00
142 A 11140 000 930 99142 142				0.00
142 A 11140 000 931 99141 141				0.00
142 A 11140 000 931 99142 142				0.00
142 A 11140 000 932 99142 142				0.00
142 A 11140 000 933 99142 142				0.00
142 A 11140 000 934 99142 142				0.00
142 A 11140 000 935 99142 142				0.00
142 A 11140 000 936 99142 142				0.00
142 A 11140 000 937 99142 142				0.00
142 A 11140 000 938 99142 142				0.00
142 A 11140 000 939 99142 142				0.00
142 A 11140 000 940 99142 142				0.00
142 A 11140 000 941 99142 142				0.00
142 A 11140 000 950 99141 141				0.00
142 A 11140 000 950 99142 142				0.00
142 A 11140 000 951 99142 142				0.00
142 A 11140 000 952 99142 142				0.00
142 A 11140 000 953 99142 142				0.00
142 A 11140 --- --- ----- ---				1,195,361.82
142 A 11400 000 900 00000 142			DUE FROM OTHER FUNDS	0.00
142 A 11400 --- --- ----- ---				0.00
142 A 11410 000 000 00000 142				0.00
142 A 11410 --- --- ----- ---				0.00
142 A 11430 000 010 00000 142			DUE FROM OTHER GOVERNMENTS	0.00
142 A 11430 000 100 00000 142			DUE FROM OTHER GOVERNMENTS	0.00
142 A 11430 000 101 00000 142			DUE FROM OTHER GOVERNMENTS	0.00
142 A 11430 000 160 00000 142			DUE FROM OTHER GOVERNMENTS	0.00
142 A 11430 000 171 00000 142			DUE FROM OTHER GOVERNMENTS	0.00
142 A 11430 000 172 00000 142			ADAPTIVE LEARNING TECH. GRANT	0.00
142 A 11430 000 200 00000 142			DUE FROM OTHER GOVERNMENTS	0.00
142 A 11430 000 300 00000 142			DUE FROM OTHER GOVERNMENTS	0.00
142 A 11430 000 440 00000 142			DUE FROM OTHER GOVERNMENTS	0.00
142 A 11430 000 580 00000 142			DUE FROM OTHER GOVERNMENTS	0.00
142 A 11430 000 700 00000 142			ARP HOMELESS 2.0	0.00
142 A 11430 000 720 00000 142			DUE FROM OTHER GOVERNMENTS	0.00
142 A 11430 000 800 00000 142			DUE FROM OTHER GOVERNMENTS	0.00
142 A 11430 000 801 00000 142			DUE FROM OTHER GOVERNMENTS	0.00

Fnd T Acct	Obj Prj Loc	Prg	Account Level	Description	Amount
A			Asset		
142 A 11430 000 802 00000 142				PERKINS-NEW SKILLS FOR YOUTH	0.00
142 A 11430 000 891 00000 142				DUE FROM OTHER GOVERNMENTS	0.00
142 A 11430 000 892 00000 142				DUE FROM OTHER GOVERNMENTS	0.00
142 A 11430 000 893 00000 142				DUE FROM OTHER GOVERNMENTS	0.00
142 A 11430 000 894 00000 142				Focus School Gray	0.00
142 A 11430 000 895 00000 142				Focus School JM	0.00
142 A 11430 000 896 00000 000				DUE FROM OTHER GOVERNMENTS	0.00
142 A 11430 000 896 00000 142				DUE FROM OTHER GOVERNMENTS	0.00
142 A 11430 000 898 00000 142				DUE FROM OTHER GOVERNMENTS	0.00
142 A 11430 000 900 00000 142				DUE FROM OTHER GOVERNMENTS	0.00
142 A 11430 000 901 00000 142				DUE FROM OTHER GOVERNMENTS	0.00
142 A 11430 000 910 00000 142				DUE FROM OTHER GOVERNMENTS	0.00
142 A 11430 000 911 00000 142				DUE FROM OTHER GOVERNMENTS	0.00
142 A 11430 000 930 00000 142				DUE FROM OTHER GOVERNMENTS	0.00
142 A 11430 000 931 00000 142				DUE FROM OTHER GOVERNMENTS	0.00
142 A 11430 000 933 00000 142				MATH IMPLEMENTATION SUPPORT GR	0.00
142 A 11430 000 934 00000 142				DUE FROM OTHER GOVERNMENTS	0.00
142 A 11430 000 935 00000 142				DUE FROM OTHER GOVERNMENTS	0.00
142 A 11430 000 937 00000 142				ESSER 3.0	0.00
142 A 11430 000 938 00000 142				BEST FOR ALL DISTRICT GRANT	0.00
142 A 11430 000 939 00000 142				DUE FROM OTHER GOVERNMENTS	0.00
142 A 11430 000 940 00000 142				EPIDEMIOOGY & LABORATORY ELC	0.00
142 A 11430 000 941 00000 142				DUE FROM OTHER GOVERNMENTS	0.00
142 A 11430 000 950 00000 142				CIVICS SEAL GRANT	0.00
142 A 11430 000 951 00000 142				HQIM LITERACY IMPLEMENTATION	0.00
142 A 11430 000 952 00000 142				EARLY LITERACY NETWORKS	0.00
142 A 11430 --- --- ----- ---					0.00
142 A 11440 000 000 00000 142				DUE FROM OTHER FUNDS	0.00
142 A 11440 000 010 00000 000				DUE FROM OTHER FUNDS-CON ADMIN	0.00
142 A 11440 000 100 00000 000				DUE FROM OTHER FUNDS	0.00
142 A 11440 000 160 00000 000				DUE FROM OTHER FUNDS	0.00
142 A 11440 000 200 00000 000				DUE FROM OTHER FUNDS	0.00
142 A 11440 000 440 00000 000				DUE FROM OTHER FUNDS	0.00
142 A 11440 000 800 00000 142				DUE FROM OTHER FUNDS-CTE BASIC	0.00
142 A 11440 000 890 00000 000				DUE FROM OTHER FUNDS	0.00
142 A 11440 000 891 00000 142				DUE FROM OTHER FUNDS-STATE DIS	0.00
142 A 11440 000 892 00000 000				DUE FROM OTHER FUNDS-DISC PREK	0.00
142 A 11440 000 895 00000 000				DUE FROM OTHER FUNDS-FS JMS	0.00
142 A 11440 000 896 00000 000				DUE FROM OTHER FUNDS-FS SS	0.00
142 A 11440 000 898 00000 000				DUE FROM OTHER FUNDS	0.00
142 A 11440 000 900 00000 000				DUE FROM OTHER FUNDS-IDEA B	0.00
142 A 11440 000 900 00000 142					0.00
142 A 11440 000 910 00000 000				DUE FROM OTHER FUNDS	0.00
142 A 11440 000 912 00000 000				DUE FROM OTHER FUNDS	0.00
142 A 11440 000 934 00000 142				DUE FROM OTHER FUNDS	0.00
142 A 11440 000 935 00000 000				DUE FROM OTHER FUNDS	0.00
142 A 11440 000 937 00000 000				DUE FROM OTHER FUNDS	0.00
142 A 11440 --- --- ----- ---					0.00
142 A 21100 000 000 00000 142				ACCOUNTS PAYABLE	0.00
142 A 21100 --- --- ----- ---					0.00
142 A 21500 000 000 00000 142				DUE TO OTHER FUNDS	0.00

Fnd T Acct	Obj Prj Loc	Prg	Account Level Description	Amount
A Asset				
142 A	21500 --- --- -----			0.00
142 A	----- --- --- -----			1,195,361.82
=====				
L Liability				
142 L	21100 000 010 00000 000		ACCOUNTS PAYABLE	0.00
142 L	21100 000 100 00000 000		ACCOUNTS PAYABLE	0.00
142 L	21100 000 101 00000 000			0.00
142 L	21100 000 160 00000 000		TITLE I-D	0.00
142 L	21100 000 171 00000 000			0.00
142 L	21100 000 172 00000 000			0.00
142 L	21100 000 200 00000 000		ACCOUNTS PAYABLE	0.00
142 L	21100 000 440 00000 000		ACCOUNTS PAYABLE	0.00
142 L	21100 000 700 00000 000			0.00
142 L	21100 000 705 00000 000			0.00
142 L	21100 000 720 00000 000			0.00
142 L	21100 000 800 00000 000		ACCOUNTS PAYABLE	0.00
142 L	21100 000 801 00000 000		ACCOUNTS PAYABLE	0.00
142 L	21100 000 802 00000 000			0.00
142 L	21100 000 803 00000 000			0.00
142 L	21100 000 890 00000 000			0.00
142 L	21100 000 891 00000 000		ACCOUNTS PAYABLE	0.00
142 L	21100 000 892 00000 000		ACCOUNTS PAYABLE	0.00
142 L	21100 000 893 00000 000		ACCOUNTS PAYABLE	0.00
142 L	21100 000 894 00000 000		ACCOUNTS PAYABLE	0.00
142 L	21100 000 895 00000 000		ACCOUNTS PAYABLE	0.00
142 L	21100 000 896 00000 000		ACCOUNTS PAYABLE	0.00
142 L	21100 000 897 00000 000			0.00
142 L	21100 000 898 00000 000			0.00
142 L	21100 000 899 00000 000			0.00
142 L	21100 000 900 00000 000		ACCOUNTS PAYABLE	0.00
142 L	21100 000 901 00000 000			0.00
142 L	21100 000 910 00000 000		ACCOUNTS PAYABLE	0.00
142 L	21100 000 911 00000 000			0.00
142 L	21100 000 912 00000 000			0.00
142 L	21100 000 930 00000 000			0.00
142 L	21100 000 931 00000 000			0.00
142 L	21100 000 932 00000 000			0.00
142 L	21100 000 933 00000 000			0.00
142 L	21100 000 934 00000 000			0.00
142 L	21100 000 935 00000 000			0.00
142 L	21100 000 936 00000 000			0.00
142 L	21100 000 937 00000 000			0.00
142 L	21100 000 938 00000 000			0.00
142 L	21100 000 939 00000 000		FISCAL PRE-MONITORING SUPPORTS	0.00
142 L	21100 000 940 00000 000			0.00
142 L	21100 000 941 00000 000			0.00
142 L	21100 000 950 00000 000			0.00
142 L	21100 000 951 00000 000			0.00
142 L	21100 000 952 00000 000			0.00
142 L	21100 000 953 00000 000			0.00

Fnd T Acct	Obj Prj Loc	Prg	Account Level Description	Amount
L			Liability	
142 L 21100	---	---	-----	0.00
142 L 21200	000 100	00000	000 ACCRUED PAYROLL	0.00
142 L 21200	000 931	00000	000 ACCRUED PAYROLL	0.00
142 L 21200	000 934	00000	000 ACCRUED PAYROLL	0.00
142 L 21200	000 935	00000	000 ACCRUED PAYROLL	0.00
<hr/>				
142 L 21200	---	---	-----	0.00
142 L 21310	000 000	00000	000	0.00
142 L 21310	000 010	00000	000 INCOME TAX WITHHELD AND UNPAID	0.00
142 L 21310	000 100	00000	000 INCOME TAX WITHHELD AND UNPAID	0.00
142 L 21310	000 160	00000	000 TITLE I-D	0.00
142 L 21310	000 200	00000	000 INCOME TAX WITHHELD AND UNPAID	0.00
142 L 21310	000 440	00000	000 INCOME TAX WITHHELD AND UNPAID	0.00
142 L 21310	000 580	00000	000 INCOME TAX WITHHELD AND UNPAID	0.00
142 L 21310	000 720	00000	000	0.00
142 L 21310	000 800	00000	000 INCOME TAX WITHHELD AND UNPAID	0.00
142 L 21310	000 890	00000	000	0.00
142 L 21310	000 891	00000	000 INCOME TAX WITHHELD AND UNPAID	0.00
142 L 21310	000 892	00000	000 INCOME TAX WITHHELD AND UNPAID	0.00
142 L 21310	000 894	00000	000 INCOME TAX WITHHELD AND UNPAID	0.00
142 L 21310	000 895	00000	000 INCOME TAX WITHHELD AND UNPAID	0.00
142 L 21310	000 896	00000	000 INCOME TAX WITHHELD AND UNPAID	0.00
142 L 21310	000 898	00000	000	0.00
142 L 21310	000 900	00000	000 INCOME TAX WITHHELD AND UNPAID	0.00
142 L 21310	000 901	00000	000	0.00
142 L 21310	000 910	00000	000 INCOME TAX WITHHELD AND UNPAID	0.00
142 L 21310	000 912	00000	000	0.00
142 L 21310	000 930	00000	000	0.00
142 L 21310	000 931	00000	000	0.00
142 L 21310	000 934	00000	000	0.00
142 L 21310	000 935	00000	000	0.00
142 L 21310	000 937	00000	000	0.00
142 L 21310	000 938	00000	000	0.00
142 L 21310	000 940	00000	000	0.00
142 L 21310	000 950	00000	000	0.00
<hr/>				
142 L 21310	---	---	-----	0.00
142 L 21320	000 000	00000	000	0.00
142 L 21320	000 010	00000	000 SOCIAL SECURITY TAX	0.00
142 L 21320	000 100	00000	000 SOCIAL SECURITY TAX	0.00
142 L 21320	000 160	00000	000 TITLE I-D	0.00
142 L 21320	000 200	00000	000 SOCIAL SECURITY TAX	0.00
142 L 21320	000 440	00000	000 SOCIAL SECURITY TAX	0.00
142 L 21320	000 580	00000	000 SOCIAL SECURITY TAX	0.00
142 L 21320	000 720	00000	000	0.00
142 L 21320	000 800	00000	000 SOCIAL SECURITY TAX	0.00
142 L 21320	000 890	00000	000	0.00
142 L 21320	000 891	00000	000 SOCIAL SECURITY TAX	0.00
142 L 21320	000 894	00000	000 SOCIAL SECURITY TAX	0.00
142 L 21320	000 895	00000	000 SOCIAL SECURITY TAX	0.00
142 L 21320	000 896	00000	000 SOCIAL SECURITY TAX	0.00
142 L 21320	000 898	00000	000	0.00
142 L 21320	000 900	00000	000 SOCIAL SECURITY TAX	11.84CR
142 L 21320	000 901	00000	000	0.00
142 L 21320	000 910	00000	000 SOCIAL SECURITY TAX	11.84

Fnd T Acct	Obj Prj Loc	Prg	Account Level Description	Amount
L			Liability	
142 L 21320	000 912	00000 000		0.00
142 L 21320	000 930	00000 000		0.00
142 L 21320	000 931	00000 000		0.00
142 L 21320	000 934	00000 000		0.00
142 L 21320	000 935	00000 000		0.00
142 L 21320	000 937	00000 000		0.00
142 L 21320	000 938	00000 000		0.00
142 L 21320	000 940	00000 000		0.00
142 L 21320	000 950	00000 000		0.00
				<hr/>
142 L 21320	---	---	-----	0.00
142 L 21325	000 000	00000 000		0.00
142 L 21325	000 010	00000 000	EMPLOYEE MEDICARE DEDUCTION	0.00
142 L 21325	000 100	00000 000	EMPLOYEE MEDICARE DEDUCTION	0.00
142 L 21325	000 160	00000 000	TITLE I-D	0.00
142 L 21325	000 200	00000 000	EMPLOYEE MEDICARE DEDUCTION	0.00
142 L 21325	000 440	00000 000	EMPLOYEE MEDICARE DEDUCTION	0.00
142 L 21325	000 580	00000 000	EMPLOYEE MEDICARE DEDUCTION	0.00
142 L 21325	000 720	00000 000		0.00
142 L 21325	000 800	00000 000	EMPLOYEE MEDICARE DEDUCTION	0.00
142 L 21325	000 890	00000 000		0.00
142 L 21325	000 891	00000 000	EMPLOYEE MEDICARE DEDUCTION	0.00
142 L 21325	000 892	00000 000	EMPLOYEE MEDICARE DEDUCTION	0.00
142 L 21325	000 894	00000 000	EMPLOYEE MEDICARE DEDUCTION	0.00
142 L 21325	000 895	00000 000	EMPLOYEE MEDICARE DEDUCTION	0.00
142 L 21325	000 896	00000 000	EMPLOYEE MEDICARE DEDUCTION	0.00
142 L 21325	000 898	00000 000		0.00
142 L 21325	000 900	00000 000	EMPLOYEE MEDICARE DEDUCTION	2.76CR
142 L 21325	000 901	00000 000		0.00
142 L 21325	000 910	00000 000	EMPLOYEE MEDICARE DEDUCTION	2.76
142 L 21325	000 912	00000 000		0.00
142 L 21325	000 930	00000 000		0.00
142 L 21325	000 931	00000 000		0.00
142 L 21325	000 934	00000 000		0.00
142 L 21325	000 935	00000 000		0.00
142 L 21325	000 937	00000 000		0.00
142 L 21325	000 938	00000 000		0.00
142 L 21325	000 940	00000 000		0.00
142 L 21325	000 950	00000 000		0.00
				<hr/>
142 L 21325	---	---	-----	0.00
142 L 21330	000 000	00000 000		0.00
142 L 21330	000 010	00000 000	RETIREMENT CONTRIBUTIONS	306.54
142 L 21330	000 100	00000 000	RETIREMENT CONTRIBUTIONS	8,780.58
142 L 21330	000 160	00000 000	RETIREMENT CONTRIBUTIONS	0.00
142 L 21330	000 200	00000 000	RETIREMENT CONTRIBUTIONS	1,973.69
142 L 21330	000 440	00000 000	RETIREMENT CONTRIBUTIONS	873.87
142 L 21330	000 580	00000 000	RETIREMENT CONTRIBUTIONS	0.00
142 L 21330	000 720	00000 000		0.00
142 L 21330	000 800	00000 000	RETIREMENT CONTRIBUTIONS	0.00
142 L 21330	000 890	00000 000		0.00
142 L 21330	000 891	00000 000	RETIREMENT CONTRIBUTIONS	0.00
142 L 21330	000 892	00000 000		0.00
142 L 21330	000 894	00000 000		0.00
142 L 21330	000 895	00000 000	RETIREMENT CONTRIBUTIONS	0.00

Fnd T Acct	Obj Prj Loc	Prg	Account Level Description	Amount
L			Liability	
142 L 21330	000 896	00000 000		1,997.66
142 L 21330	000 898	00000 000		0.00
142 L 21330	000 900	00000 000	RETIREMENT CONTRIBUTIONS	16,967.92
142 L 21330	000 901	00000 000		0.00
142 L 21330	000 910	00000 000	RETIREMENT CONTRIBUTIONS	409.27
142 L 21330	000 912	00000 000		0.00
142 L 21330	000 930	00000 000		0.00
142 L 21330	000 931	00000 000		0.00
142 L 21330	000 934	00000 000		0.00
142 L 21330	000 935	00000 000		0.00
142 L 21330	000 937	00000 000		0.00
142 L 21330	000 938	00000 000		0.00
142 L 21330	000 940	00000 000		0.00
142 L 21330	000 950	00000 000		0.00
				<hr/>
142 L 21330	---	---	-----	31,309.53
142 L 21339	000 000	00000 000		0.00
142 L 21339	000 010	00000 000	STATE DENTAL PLAN	0.00
142 L 21339	000 100	00000 000	STATE DENTAL PLAN	2,136.91CR
142 L 21339	000 160	00000 000	STATE DENTAL PLAN	0.00
142 L 21339	000 200	00000 000	STATE DENTAL PLAN	324.61CR
142 L 21339	000 440	00000 000	STATE DENTAL PLAN	32.05CR
142 L 21339	000 580	00000 000	STATE DENTAL PLAN	0.00
142 L 21339	000 800	00000 000	STATE DENTAL PLAN	0.00
142 L 21339	000 891	00000 000	STATE DENTAL PLAN	0.00
142 L 21339	000 892	00000 000	STATE DENTAL PLAN	0.00
142 L 21339	000 900	00000 000	STATE DENTAL PLAN	944.00
142 L 21339	000 901	00000 000		0.00
142 L 21339	000 910	00000 000		0.00
142 L 21339	000 934	00000 000		0.00
142 L 21339	000 937	00000 000		0.00
				<hr/>
142 L 21339	---	---	-----	1,549.57CR
142 L 21340	000 000	00000 000		0.00
142 L 21340	000 010	00000 000	INSURANCE CONTRIBUTIONS	0.00
142 L 21340	000 100	00000 000	INSURANCE CONTRIBUTIONS	250.00
142 L 21340	000 160	00000 000	INSURANCE CONTRIBUTIONS	0.00
142 L 21340	000 200	00000 000	INSURANCE CONTRIBUTIONS	0.00
142 L 21340	000 440	00000 000	INSURANCE CONTRIBUTIONS	0.00
142 L 21340	000 580	00000 000	INSURANCE CONTRIBUTIONS	0.00
142 L 21340	000 800	00000 000	INSURANCE CONTRIBUTIONS	0.00
142 L 21340	000 891	00000 000	INSURANCE CONTRIBUTIONS	0.00
142 L 21340	000 892	00000 000	MEDICAL INSURANCE PAYABLE	0.00
142 L 21340	000 900	00000 000	INSURANCE CONTRIBUTIONS	1,550.00
142 L 21340	000 910	00000 000	INSURANCE CONTRIBUTIONS	0.00
142 L 21340	000 937	00000 000		0.00
				<hr/>
142 L 21340	---	---	-----	1,800.00
142 L 21342	000 010	00000 000		0.00
142 L 21342	000 100	00000 000	HARTFORD ROTH	0.00
142 L 21342	000 160	00000 000	HARTFORD ROTH	0.00
142 L 21342	000 200	00000 000	HARTFORD ROTH	0.00
142 L 21342	000 440	00000 000	HARTFORD ROTH	0.00
142 L 21342	000 900	00000 000	HARTFORD ROTH	0.00
142 L 21342	000 910	00000 000		0.00

Fnd T Acct	Obj Prj Loc	Prg	Account Level Description	Amount
L			Liability	
142 L 21342	---	---	-----	0.00
142 L 21343	000	000	00000 000	0.00
142 L 21343	000	010	00000 000 AMERICAN FAMILY LIFE	0.00
142 L 21343	000	100	00000 000 AMERICAN FAMILY LIFE	0.00
142 L 21343	000	160	00000 000 AMERICAN FAMILY LIFE	0.00
142 L 21343	000	200	00000 000 AMERICAN FAMILY LIFE	0.00
142 L 21343	000	440	00000 000 AMERICAN FAMILY LIFE	0.00
142 L 21343	000	800	00000 000 AMERICAN FAMILY LIFE	0.00
142 L 21343	000	900	00000 000 AMERICAN FAMILY LIFE	15.88
142 L 21343	000	901	00000 000	0.00
142 L 21343	000	910	00000 000 AMERICAN FAMILY LIFE	0.00
142 L 21343	000	912	00000 000	0.00
142 L 21343	000	930	00000 000	0.00
142 L 21343	000	934	00000 000	0.00
142 L 21343	000	937	00000 000	0.00
142 L 21343	000	940	00000 000	0.00
142 L 21343	---	---	-----	15.88
142 L 21344	000	100	00000 000 HORACE MANN LIFE INS	0.00
142 L 21344	000	160	00000 000 TITLE I-D	0.00
142 L 21344	000	900	00000 000 HORACE MANN LIFE INS	0.00
142 L 21344	---	---	-----	0.00
142 L 21346	000	000	00000 000	0.00
142 L 21346	000	010	00000 000 WASHINGTON NATIONAL INS	0.00
142 L 21346	000	160	00000 000 TITLE I-D	0.00
142 L 21346	000	900	00000 000 WASHINGTON NATIONAL INS	0.00
142 L 21346	000	910	00000 000 WASHINGTON NATIONAL INS	0.00
142 L 21346	---	---	-----	0.00
142 L 21347	000	000	00000 000	0.00
142 L 21347	000	100	00000 000 LIBERTY NATIONAL	0.00
142 L 21347	000	440	00000 000 LIBERTY NATIONAL	0.00
142 L 21347	000	800	00000 000 DEARBORN NATIONAL LIFE INSURAN	0.00
142 L 21347	000	900	00000 000 LIBERTY NATIONAL	0.00
142 L 21347	000	910	00000 000 LIBERTY NATIONAL	0.00
142 L 21347	---	---	-----	0.00
142 L 21348	000	000	00000 000	0.00
142 L 21348	000	010	00000 000 MEDICAL INSURANCE	0.00
142 L 21348	000	100	00000 000 MEDICAL INSURANCE	0.00
142 L 21348	000	160	00000 000 MEDICAL INSURANCE	0.00
142 L 21348	000	200	00000 000 EMPLOYEE INSURANCE DEDUCTIONS	0.00
142 L 21348	000	440	00000 000 MEDICAL INSURANCE	0.00
142 L 21348	000	580	00000 000 MEDICAL INSURANCE	0.00
142 L 21348	000	800	00000 000 MEDICAL INSURANCE	0.00
142 L 21348	000	891	00000 000 EMPLOYEE INSURANCE DEDUCTIONS	0.00
142 L 21348	000	900	00000 000 MEDICAL INSURANCE	491.67
142 L 21348	000	910	00000 000 MEDICAL INSURANCE	0.00
142 L 21348	000	937	00000 000	0.00
142 L 21348	---	---	-----	491.67
142 L 21349	000	010	00000 000	0.00
142 L 21349	000	100	00000 000 UNITED WAY	0.00

Fnd T Acct	Obj Prj Loc	Prg	Account Level Description	Amount
L			Liability	
142 L 21349	000 200 00000	000		0.00
142 L 21349	000 440 00000	000		0.00
142 L 21349	000 900 00000	000	UNITED WAY	0.00
142 L 21349	000 912 00000	000		0.00
142 L 21349	000 937 00000	000		0.00
				<hr/>
142 L 21349	---	---	-----	0.00
142 L 21351	000 010 00000	000	HORACE MANN ANNUITY	0.00
142 L 21351	000 100 00000	000	HORACE MANN ANNUITY	0.00
142 L 21351	000 160 00000	000	HORACE MANN ANNUITY	0.00
142 L 21351	000 200 00000	000	HORACE MANN ANNUITY	0.00
142 L 21351	000 440 00000	000	HORACE MANN ANNUITY	0.00
142 L 21351	000 580 00000	000	HORACE MANN ANNUITY	0.00
				<hr/>
142 L 21351	---	---	-----	0.00
142 L 21353	000 000 00000	000		0.00
142 L 21353	000 010 00000	000	DAVIS VISION	0.00
142 L 21353	000 100 00000	000	DAVIS VISION	451.08CR
142 L 21353	000 160 00000	000	DAVIS VISION	0.00
142 L 21353	000 200 00000	000	DAVIS VISION	36.24CR
142 L 21353	000 440 00000	000	DAVIS VISION	36.24CR
142 L 21353	000 580 00000	000	DAVIS VISION	0.00
142 L 21353	000 800 00000	000	DAVIS VISION	0.00
142 L 21353	000 900 00000	000	DAVIS VISION	535.55CR
142 L 21353	000 937 00000	000		0.00
				<hr/>
142 L 21353	---	---	-----	1,059.11CR
142 L 21354	000 000 00000	000	ONE AMERICA	0.00
142 L 21354	000 100 00000	000	ONE AMERICA	0.00
142 L 21354	000 160 00000	000	ONE AMERICA	0.00
142 L 21354	000 200 00000	000	ONE AMERICA	0.00
142 L 21354	000 440 00000	000	ONE AMERICA	0.00
142 L 21354	000 580 00000	000	ONE AMERICA	0.00
142 L 21354	000 800 00000	000	ONE AMERICA	0.00
142 L 21354	000 891 00000	000	ONE AMERICA	0.00
142 L 21354	000 900 00000	000	ONE AMERICA	17.46CR
142 L 21354	000 901 00000	000	ARP IDEA PART B	0.00
142 L 21354	000 910 00000	000	ONE AMERICA	0.00
142 L 21354	000 937 00000	000		0.00
				<hr/>
142 L 21354	---	---	-----	17.46CR
142 L 21356	000 100 00000	000	TRUSTMARK	0.00
142 L 21356	000 160 00000	000	TRUSTMARK	0.00
142 L 21356	000 200 00000	000	TRUSTMARK	0.00
142 L 21356	000 900 00000	000	TRUSTMARK	15.92CR
				<hr/>
142 L 21356	---	---	-----	15.92CR
142 L 21357	000 100 00000	000	MODERN WOODMEN INS PAYABL	0.00
				<hr/>
142 L 21357	---	---	-----	0.00
142 L 21358	000 100 00000	000	HYBRID TAXED CONTRIBUTION	0.00
142 L 21358	000 890 00000	000		0.00
142 L 21358	000 896 00000	000	HYBRID TAXED CONTRIBUTION	30.00
142 L 21358	000 898 00000	000		0.00
142 L 21358	000 934 00000	000	HYBRID TAXED CONTRIBUTION	0.00

Fnd T Acct	Obj Prj Loc	Prg	Account Level Description	Amount
L			Liability	
142 L 21358	000 935 00000 000		HYBRID TAXED CONTRIBUTION	0.00
142 L 21358	000 937 00000 000		HYBRID TAXED CONTRIBUTION	0.00
142 L 21358	--- --- ----- ---			30.00
142 L 21359	000 000 00000 000		HYBRID PRETAXED CONTRIBUTION	0.00
142 L 21359	000 010 00000 000			0.00
142 L 21359	000 100 00000 000		HYBRID PRETAXED CONTRIBUTION	95.64
142 L 21359	000 200 00000 000		HYBRID PRETAXED CONTRIBUTION	0.00
142 L 21359	000 440 00000 000		HYBRID PRETAXED CONTRIBUTION	0.00
142 L 21359	000 720 00000 000			0.00
142 L 21359	000 890 00000 000			0.00
142 L 21359	000 891 00000 000		HYBRID PRETAXED CONTRIBUTION	0.00
142 L 21359	000 896 00000 000			61.95
142 L 21359	000 898 00000 000			0.00
142 L 21359	000 900 00000 000		HYBRID PRETAXED CONTRIBUTION	708.58
142 L 21359	000 901 00000 000			0.00
142 L 21359	000 930 00000 000			0.00
142 L 21359	000 931 00000 000			0.00
142 L 21359	000 934 00000 000			0.00
142 L 21359	000 935 00000 000			0.00
142 L 21359	000 937 00000 000			0.00
142 L 21359	000 938 00000 000			0.00
142 L 21359	000 940 00000 000			0.00
142 L 21359	--- --- ----- ---			866.17
142 L 21360	000 100 00000 000		GARNISHMENTS AND LEVIES	2,181.76CR
142 L 21360	000 900 00000 000		GARNISHMENTS AND LEVIES	373.70
142 L 21360	000 934 00000 000			0.00
142 L 21360	000 935 00000 000			0.00
142 L 21360	--- --- ----- ---			1,808.06CR
142 L 21362	000 000 00000 000			0.00
142 L 21362	000 100 00000 000		USABLE LIFE INS	0.00
142 L 21362	000 200 00000 000		USABLE LIFE INS	0.00
142 L 21362	000 580 00000 000		USABLE LIFE INS	0.00
142 L 21362	000 800 00000 000		USABLE Life	0.00
142 L 21362	000 900 00000 000		USABLE LIFE INS	0.00
142 L 21362	000 910 00000 000		USABLE LIFE INS	0.00
142 L 21362	201 000 00000 000			0.00
142 L 21362	201 100 00000 000		SOCIAL SECURITY	0.00
142 L 21362	201 200 00000 000		SOCIAL SECURITY	0.00
142 L 21362	201 900 00000 000		SOCIAL SECURITY	0.00
142 L 21362	201 910 00000 000		SOCIAL SECURITY	0.00
142 L 21362	204 000 00000 000			0.00
142 L 21362	204 100 00000 000		STATE RETIREMENT	0.00
142 L 21362	204 200 00000 000		STATE RETIREMENT	0.00
142 L 21362	204 900 00000 000		STATE RETIREMENT	0.00
142 L 21362	204 910 00000 000		STATE RETIREMENT	0.00
142 L 21362	207 000 00000 000			0.00
142 L 21362	207 100 00000 000		MEDICAL INSURANCE	0.00
142 L 21362	207 160 00000 000		MEDICAL INSURANCE	0.00
142 L 21362	207 200 00000 000		MEDICAL INSURANCE	0.00
142 L 21362	207 900 00000 000		MEDICAL INSURANCE	0.00
142 L 21362	207 910 00000 000		MEDICAL INSURANCE	0.00
142 L 21362	212 000 00000 000			0.00

Fnd T Acct	Obj Prj Loc	Prg	Account Level Description	Amount
L			Liability	
142 L 21362	212 100	00000 000	MEDICARE	0.00
142 L 21362	212 200	00000 000	MEDICARE	0.00
142 L 21362	212 900	00000 000	MEDICARE	0.00
142 L 21362	212 910	00000 000	MEDICARE	0.00
<hr/>				
142 L 21362	---	---	-----	0.00
142 L 21365	000 010	00000 000		0.00
142 L 21365	000 100	00000 000	WAGWORKS	0.00
142 L 21365	000 200	00000 000	WAGWORKS	0.00
142 L 21365	000 580	00000 000	WAGWORKS	0.00
142 L 21365	000 900	00000 000	WAGWORKS	0.00
142 L 21365	000 912	00000 000		0.00
<hr/>				
142 L 21365	---	---	-----	0.00
142 L 21366	000 100	00000 000		0.00
142 L 21366	000 200	00000 000		0.00
142 L 21366	000 900	00000 000	LSW/VALUE TEACH	0.00
142 L 21366	000 937	00000 000		0.00
<hr/>				
142 L 21366	---	---	-----	0.00
142 L 21370	000 010	00000 000	AIG RETIREMENT (VALIC)	0.00
142 L 21370	000 100	00000 000	AIG RETIREMENT (VALIC)	0.00
142 L 21370	000 200	00000 000	AIG RETIREMENT (VALIC)	0.00
142 L 21370	000 440	00000 000	AIG RETIREMENT (VALIC)	0.00
<hr/>				
142 L 21370	---	---	-----	0.00
142 L 21380	000 010	00000 000	CREDIT UNION DEDUCTION	0.00
142 L 21380	000 100	00000 000	CREDIT UNION DEDUCTION	0.00
142 L 21380	000 580	00000 000	CREDIT UNION DEDUCTION	0.00
<hr/>				
142 L 21380	---	---	-----	0.00
142 L 21390	000 010	00000 000	NEA TEA WCEA DUES	0.00
142 L 21390	000 100	00000 000	NEA TEA WCEA DUES	0.00
142 L 21390	000 200	00000 000	NEA TEA WCEA DUES	0.00
142 L 21390	000 580	00000 000	NEA TEA WCEA DUES	0.00
142 L 21390	000 900	00000 000	NEA TEA WCEA DUES	0.00
<hr/>				
142 L 21390	---	---	-----	0.00
142 L 21392	000 900	00000 000		0.00
<hr/>				
142 L 21392	---	---	-----	0.00
142 L 21500	000 000	00000 000		0.00
142 L 21500	000 010	00000 000	DUE TO OTHER FUNDS	0.00
142 L 21500	000 100	00000 000	DUE TO OTHER FUNDS	0.00
142 L 21500	000 160	00000 000	DUE TO OTHER FUNDS	0.00
142 L 21500	000 200	00000 000	DUE TO OTHER FUNDS	0.00
142 L 21500	000 300	00000 000	DUE TO OTHER FUNDS	0.00
142 L 21500	000 440	00000 000	DUE TO OTHER FUNDS	0.00
142 L 21500	000 720	00000 000	DUE TO OTHER FUNDS	0.00
142 L 21500	000 800	00000 000	DUE TO OTHER FUNDS	0.00
142 L 21500	000 891	00000 000	DUE TO OTHER FUNDS	0.00
142 L 21500	000 892	00000 000	DUE TO OTHER FUNDS	0.00
142 L 21500	000 894	00000 000	DUE TO OTHER FUNDS	0.00
142 L 21500	000 896	00000 000	Due To Other Funds	0.00
142 L 21500	000 900	00000 000	DUE TO OTHER FUNDS	0.00

Fnd T Acct	Obj Prj Loc	Prg	Account Level Description	Amount
L			Liability	
142 L 21500 000 901 00000 000			DUE TO OTHER FUNDS	0.00
142 L 21500 000 910 00000 000			DUE TO OTHER FUNDS	0.00
142 L 21500 000 934 00000 000			DUE TO OTHER FUNDS	0.00
142 L 21500 000 935 00000 000			DUE TO OTHER FUNDS	0.00
142 L 21500 000 938 00000 000			BEST FOR ALL DISTRICT GRANT	0.00
142 L 21500 000 940 00000 000			Due To Other Funds	0.00
<hr/>				0.00
142 L 21500 --- --- ----- ---				
142 L 21530 000 000 00000 000			DUE TO STATE OF TENNESSEE	0.00
142 L 21530 000 010 00000 000			DUE TO STATE OF TENNESSEE	0.00
142 L 21530 000 200 00000 000			DUE TO STATE OF TENNESSEE	0.00
142 L 21530 000 800 00000 000			DUE TO STATE OF TN	0.00
142 L 21530 000 892 00000 000			Due to State of Tennessee	0.00
142 L 21530 000 900 00000 000			DUE TO STATE OF TENNESSEE	0.00
<hr/>				0.00
142 L 21530 --- --- ----- ---				
142 L 21535 000 100 00000 000			DAVIS VISION	0.00
<hr/>				0.00
142 L 21535 --- --- ----- ---				
142 L 21900 000 000 00000 000				0.00
142 L 21900 000 010 00000 000			OTHER CURRENT LIABILITIES	0.00
142 L 21900 000 100 00000 000			OTHER CURRENT LIABILITIES	0.00
142 L 21900 000 160 00000 000			OTHER CURRENT LIABILITIES	0.00
142 L 21900 000 200 00000 000			OTHER CURRENT LIABILITIES	0.00
142 L 21900 000 440 00000 000			OTHER CURRENT LIABILITIES	0.00
142 L 21900 000 720 00000 000				0.00
142 L 21900 000 800 00000 000			OTHER CURRENT LIABILITIES	0.00
142 L 21900 000 890 00000 000				0.00
142 L 21900 000 891 00000 000			OTHER CURRENT LIABILITIES	0.00
142 L 21900 000 894 00000 000			OTHER CURRENT LIABILITIES	0.00
142 L 21900 000 895 00000 000			OTHER CURRENT LIABILITIES	0.00
142 L 21900 000 896 00000 000			OTHER CURRENT LIABILITIES	0.00
142 L 21900 000 898 00000 000				0.00
142 L 21900 000 900 00000 000			OTHER CURRENT LIABILITIES	0.00
142 L 21900 000 901 00000 000				0.00
142 L 21900 000 910 00000 000			OTHER CURRENT LIABILITIES	0.00
142 L 21900 000 912 00000 000				0.00
142 L 21900 000 930 00000 000				0.00
142 L 21900 000 931 00000 000				0.00
142 L 21900 000 934 00000 000				0.00
142 L 21900 000 935 00000 000				0.00
142 L 21900 000 937 00000 000				0.00
142 L 21900 000 938 00000 000				0.00
142 L 21900 000 940 00000 000				0.00
142 L 21900 000 950 00000 000				0.00
<hr/>				0.00
142 L 21900 --- --- ----- ---				
<hr/>				30,063.13
<hr/>				=====

Fnd T	Acct	Obj	Prj	Loc	Prg	Account Level Description	Amount
Q						Equity	
142	Q	34100	000	800	00000	000 PO PAYABLE	0.00
142	Q	34100	---	---	-----	---	0.00
142	Q	34110	000	000	00000	000 PURCHASE ORDER PAYABLE	0.00
142	Q	34110	000	100	00000	000 PURCHASE ORDER PAYABLE	0.00
142	Q	34110	000	160	00000	000 PURCHASE ORDER PAYABLE	0.00
142	Q	34110	000	200	00000	000 PURCHASE ORDER PAYABLE	0.00
142	Q	34110	000	440	00000	000 PURCHASE ORDER PAYABLE	0.00
142	Q	34110	000	800	00000	000 PURCHASE ORDER PAYABLE	0.00
142	Q	34110	000	891	00000	000 PURCHASE ORDER PAYABLE	0.00
142	Q	34110	000	892	00000	000 PURCHASE ORDER PAYABLE	0.00
142	Q	34110	000	893	00000	000 PURCHASE ORDER PAYABLE	0.00
142	Q	34110	---	---	-----	---	0.00
142	Q	34111	000	000	00000	000	0.00
142	Q	34111	---	---	-----	---	0.00
142	Q	34120	000	000	00000	000	0.00
142	Q	34120	---	---	-----	---	0.00
142	Q	34555	000	010	00000	000 RESTRICTED FOR ED.-CARRY FORW	0.00
142	Q	34555	000	100	00000	000 RESTRICTED FOR ED.-CARRY FORW	0.00
142	Q	34555	000	901	00000	000 RESTRICTED FOR ED.-CARRY FORW	0.00
142	Q	34555	000	937	00000	000 RESTRICTED FOR ED.-CARRY FORW	0.00
142	Q	34555	---	---	-----	---	0.00
142	Q	39000	000	000	00000	000	1,490,602.68CR
142	Q	39000	000	010	00000	000 REV EXP SUMMARY FLOW THROUGH	3,154.13
142	Q	39000	000	100	00000	000 REV EXP SUMMARY FLOW THROUGH	1,315.90
142	Q	39000	000	101	00000	000	0.00
142	Q	39000	000	160	00000	000 REV EXP SUMMARY FLOW THROUGH	532.90
142	Q	39000	000	171	00000	000	0.00
142	Q	39000	000	172	00000	000	0.00
142	Q	39000	000	200	00000	000 REV EXP SUMMARY FLOW THROUGH	0.00
142	Q	39000	000	440	00000	000 REV EXP SUMMARY FLOW THROUGH	0.00
142	Q	39000	000	700	00000	000	0.00
142	Q	39000	000	705	00000	000	0.00
142	Q	39000	000	720	00000	000	0.00
142	Q	39000	000	800	00000	000 REV EXP SUMMARY FLOW THROUGH	3,922.00
142	Q	39000	000	801	00000	000 REV EXP SUMMARY FLOW THROUGH	0.00
142	Q	39000	000	802	00000	000	0.00
142	Q	39000	000	803	00000	000	0.00
142	Q	39000	000	890	00000	000	0.00
142	Q	39000	000	891	00000	000 REV EXP SUMMARY FLOW THROUGH	0.00
142	Q	39000	000	892	00000	000 REV EXP SUMMARY FLOW THROUGH	0.00
142	Q	39000	000	893	00000	000 REV EXP SUMMARY FLOW THROUGH	0.00
142	Q	39000	000	894	00000	000 REV EXP SUMMARY FLOW THROUGH	0.00
142	Q	39000	000	895	00000	000 REV EXP SUMMARY FLOW THROUGH	0.00
142	Q	39000	000	896	00000	000 REV EXP SUMMARY FLOW THROUGH	49,088.67
142	Q	39000	000	897	00000	000	0.00
142	Q	39000	000	898	00000	000	6,365.66
142	Q	39000	000	899	00000	000	0.00
142	Q	39000	000	900	00000	000 REV EXP SUMMARY FLOW THROUGH	189,010.81
142	Q	39000	000	901	00000	000	0.00
142	Q	39000	000	910	00000	000 REV EXP SUMMARY FLOW THROUGH	11,787.66

Account Level						Amount		
Fnd	T	Acct	Obj	Prj	Loc	Prg	Description	
Equity								
142	Q	39000	000	911	00000	000		0.00
142	Q	39000	000	912	00000	000		0.00
142	Q	39000	000	930	00000	000		0.00
142	Q	39000	000	931	00000	000		0.00
142	Q	39000	000	932	00000	000		0.00
142	Q	39000	000	933	00000	000		0.00
142	Q	39000	000	934	00000	000		0.00
142	Q	39000	000	935	00000	000		0.00
142	Q	39000	000	936	00000	000		0.00
142	Q	39000	000	937	00000	000		0.00
142	Q	39000	000	938	00000	000		0.00
142	Q	39000	000	939	00000	000		0.00
142	Q	39000	000	940	00000	000		0.00
142	Q	39000	000	941	00000	000		0.00
142	Q	39000	000	950	00000	000		0.00
142	Q	39000	000	951	00000	000		0.00
142	Q	39000	000	952	00000	000		0.00
142	Q	39000	000	953	00000	000		0.00
<hr/>								
142	Q	39000	---	---	-----	---		1,225,424.95CR
<hr/>								
142	Q	-----	---	---	-----	---		1,225,424.95CR
<hr/>								
Grand Asset Totals								1,195,361.82
Grand Liability Totals								30,063.13
Grand Equity Totals								1,225,424.95CR
Grand Totals								0.00

Number of Accounts: 624

***** End of report *****

Unreconciled Dietary Fund Balance Tracking

	July	August	September	October	November	December	January	February	March	April	May	June
FY17	6,202	(380)	87,719	(66,933)	(96,404)	(260,230)	(170,632)	(57,070)	(94,864)	(76,733)	(74,830)	84,303
FY18	81,487	10,761	28,355	23,814	82,977	36,830	147,998	48,470	185,611	215,506	186,942	312,172
FY19	311,869	220,005	227,069	112,592	210,288	207,552	396,827	448,818	501,337	620,464	695,028	770,132
FY20	816,142	703,889	732,436	562,564	839,293	839,293	953,189	976,954	945,748	723,166	1,157,314	1,392,339
FY21	1,479,368	1,498,922	1,261,684	1,274,533	1,333,983	1,347,174	1,484,634	1,474,184	1,431,524	1,545,728	1,716,753	1,785,613
FY22	1,654,099	1,538,429	1,217,086	1,406,456	1,790,311	2,004,343	2,074,339	2,217,053	2,325,747	2,774,409	2,852,626	3,109,613
FY23	3,115,147	2,773,071	2,847,653	2,949,627	2,926,536	2,682,682	2,867,611	2,948,347	3,044,466	3,277,362	3,235,955	3,655,892
FY24	3,441,240	2,940,960	2,768,355	2,811,671	2,535,393	2,862,991	2,724,081	2,763,271	2,845,102	2,445,535	2,083,622	2,566,228
FY25	2,560,002	2,143,807	2,056,961	2,063,031	1,607,992	1,447,293	1,809,115	1,740,494	1,759,846	1,287,333	1,695,197	1,551,457
FY26	1,935,217	1,607,245	1,497,479	1,678,629	1,494,656	1,439,782	1,555,724	1,592,093	1,706,598			
Variance From PY	(624,785)	(536,562)	(559,482)	(384,402)	(113,336)	(7,511)	(253,391)	(188,460)	(53,248)			
Variance From PM	383,760	(327,972)	(109,766)	181,149	(183,973)	(54,873)	115,941	(3,690)	154,564			

Dietary Fund Balance Tracking FY22 to FY26 (Trustee's Report)

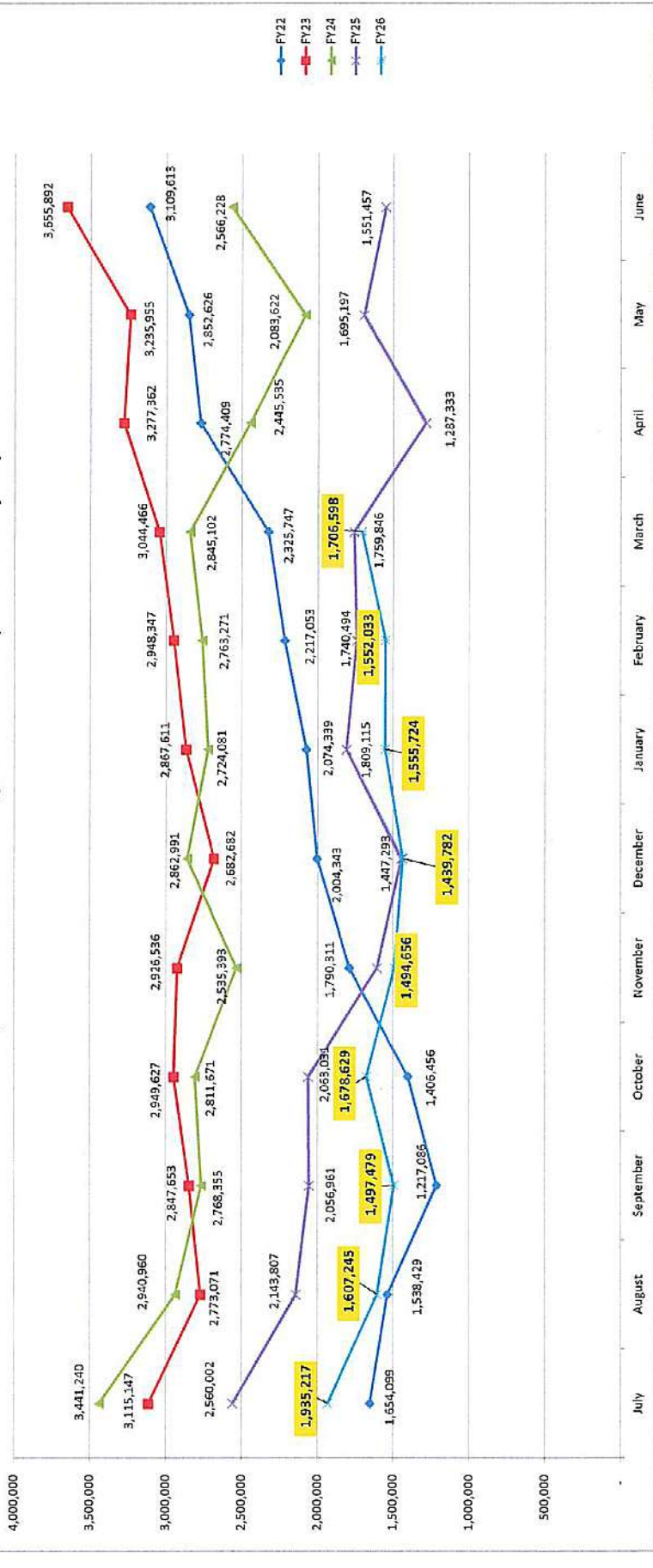

Revenue Comparison

	July	August	September	October	November	December	January	February	March	April	May	June	Totals-March 2026
FY21	180,856	132,392	4,635	279,041	290,918	265,988	316,656	273,936	253,342	383,828	476,272	261,460	1,997,764
FY22	188	238,593	43,480	465,326	869,463	545,619	349,424	478,400	550,353	730,850	573,429	468,239	3,540,846
FY23	136,432	10,497	364,883	395,361	288,979	140,146	488,928	430,937	384,305	577,919	723,278	569,779	2,640,469
FY24	83,381	50,435	398,486	393,670	120,676	679,644	249,397	427,574	390,999	332,640	102,548	636,013	2,794,263
FY25	125,697	95,284	395,316	426,278	55,690	340,045	673,804	383,664	440,849	72,358	841,012	12,550	2,936,625
FY26	542,935	122,389	498,979	552,552	347,214	495,908	414,694	367,291	421,638				3,763,600
Net Change PY	417,238	27,105	103,662	126,274	291,525	155,863	(259,110)	(16,373)	(19,211)				826,974

PY % Change	28%
Less Revenue Accruals	350,770
Revenue Increase %	9.32%

Dietary Revenue Trends FY23 Through FY26

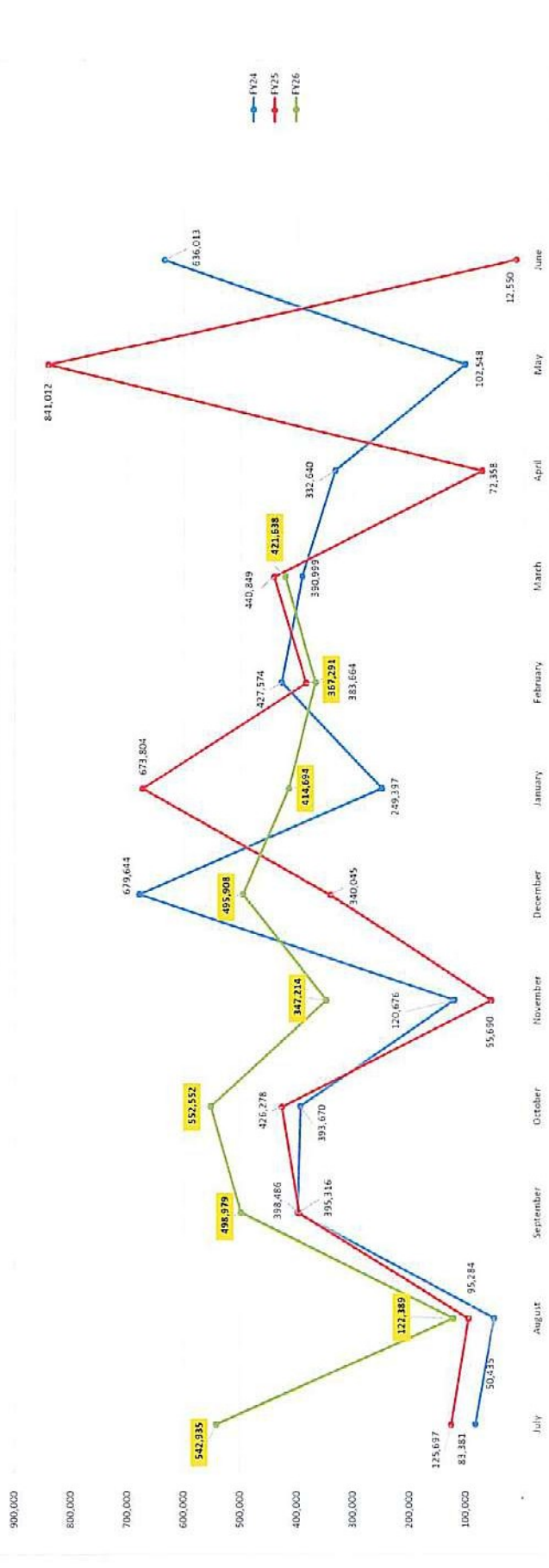

Expense Comparison

	July	August	September	October	November	December	January	February	March	April	May	June	Totals-March 2026
FY21	93,828	112,838	241,872	266,192	231,469	252,797	179,196	284,385	296,002	269,623	305,248	192,600	1,956,579
FY22	131,701	354,264	364,824	275,956	485,607	331,587	279,428	335,685	441,659	282,188	495,212	211,252	3,000,711
FY23	130,898	352,573	290,302	293,387	312,070	384,000	303,999	350,201	288,185	345,025	314,684	149,842	2,705,616
FY24	298,032	550,715	571,092	350,354	396,954	352,046	388,307	388,385	309,169	732,206	464,462	153,425	3,605,053
FY25	131,922	511,480	482,162	420,208	510,728	500,743	311,983	452,284	421,496	544,871	433,149	156,289	3,743,007
FY26	159,175	450,361	608,745	371,402	531,187	550,781	298,752	370,981	267,073				3,608,460
Net Change PY	27,253	(61,119)	126,583	(48,806)	20,459	50,038	(13,230)	(81,303)	(154,423)				(134,548)
													PY% Change
													-3.59%

Dietary Expense Trends FY23 through FY26

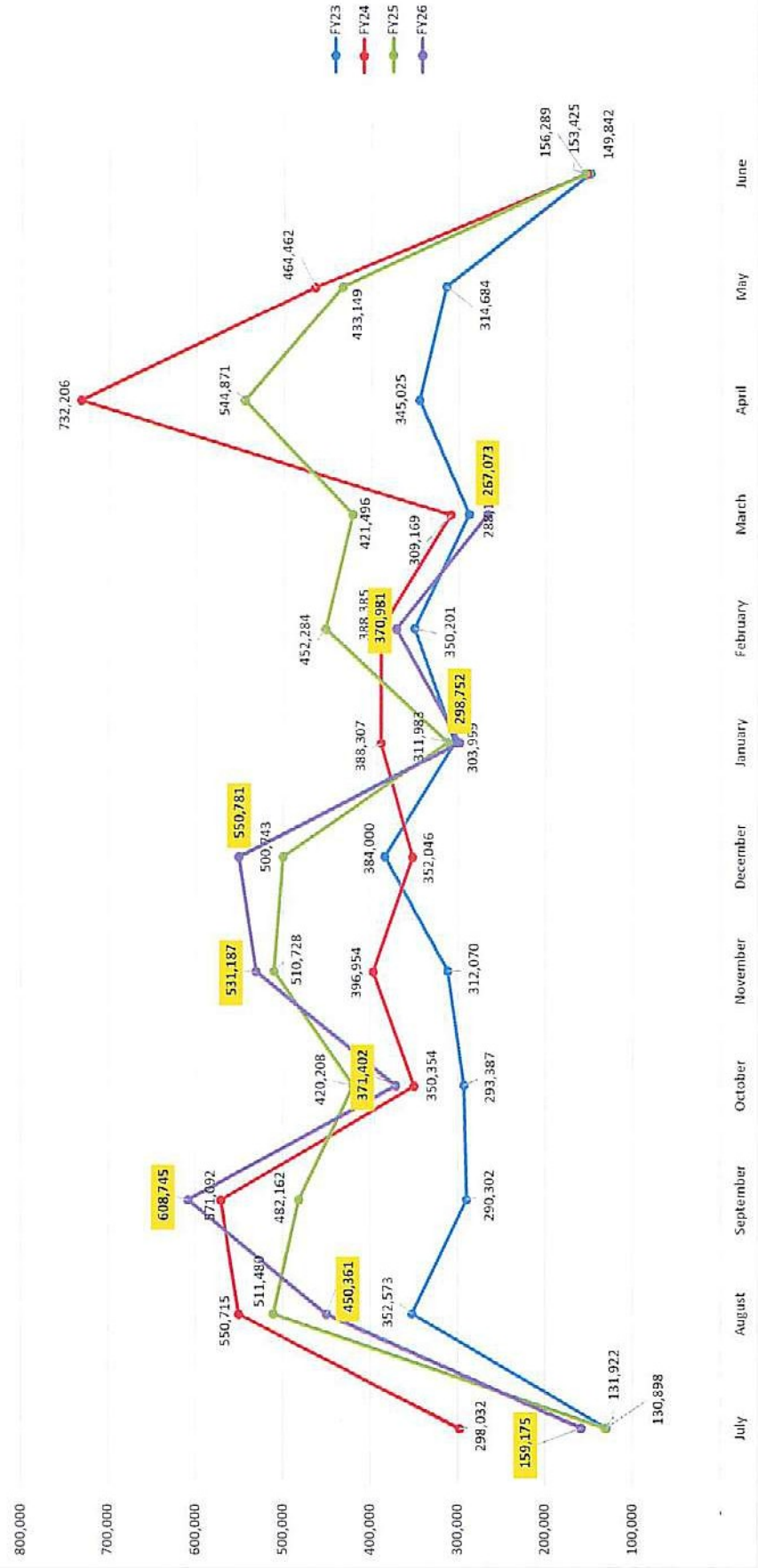

DBHS Chart of Accounts
L-Accounts are Restricted Accounts
4/27/2026

Account Number

Fnd T Acct Obj Prj Loc Prg	Beginning Balance	Debit Amount	Credit Amount	Ending Balance	Account Level Description
145 A 00000 000 000 15000 100	\$ 746,069.63	\$ 642,569.08	\$ 558,886.71	\$ 829,752.00	CASH IN BANK - CHECKING

Account Number

Fnd T Acct Obj Prj Loc Prg	Beginning Balance	Debit Amount	Credit Amount	Ending Balance	Account Level Description
145 L 00000 000 000 15000 800	\$ (97.75)	\$ -	\$ -	\$ (97.75)	ACADEMIC TEAM
145 L 00000 000 000 15000 200	\$ 0.33	\$ -	\$ -	\$ 0.33	ACCOUNTS PAYABLE
145 L 00000 000 000 15000 900	\$ (191.44)	\$ 1,027.83	\$ 2,217.24	\$ (1,380.85)	ADMINISTRATIVE
145 L 00000 000 000 15000 803	\$ (10,344.03)	\$ -	\$ 4,800.00	\$ (15,144.03)	ART
145 L 00000 000 000 15000 616	\$ (110.00)	\$ -	\$ -	\$ (110.00)	ATHLETIC EQUIPMENT
145 L 00000 000 000 15000 602	\$ -	\$ -	\$ -	\$ -	ATHLETIC RESERVE
145 L 00000 000 000 15000 620	\$ (2,222.78)	\$ 12,913.94	\$ 12,675.58	\$ (1,984.42)	ATHLETICS - MIDDLE SCHOOL
145 L 00000 000 000 15000 601	\$ -	\$ -	\$ -	\$ -	ATHLETICS - OTHER
145 L 00000 000 000 15000 617	\$ (3,946.66)	\$ 1,098.00	\$ 14,300.00	\$ (17,148.66)	ATHLETICS - SP/RESERVE
145 L 00000 000 000 15000 614	\$ (3,835.52)	\$ 4,277.52	\$ 2,717.52	\$ (2,275.52)	ATHLETICS - TRAINING ROOM
145 L 00000 000 000 15000 615	\$ (720.35)	\$ -	\$ -	\$ (720.35)	ATHLETICS - WEIGHT ROOM
145 L 00000 000 000 15000 600	\$ (17,944.29)	\$ 209,342.49	\$ 196,493.72	\$ (5,095.52)	ATHLETICS-GENERAL
145 L 00000 000 000 15000 914	\$ -	\$ 3,161.27	\$ 9,780.00	\$ (6,618.73)	BAND
145 L 00000 000 000 15000 604	\$ (7,955.29)	\$ 16,304.91	\$ 25,063.22	\$ (16,713.60)	BASEBALL
145 L 00000 001 000 15000 605	\$ (3,861.79)	\$ 27,242.24	\$ 39,845.84	\$ (16,465.39)	BASKETBALL - BOYS
145 L 00000 002 000 15000 605	\$ (7,355.58)	\$ 17,082.60	\$ 26,476.14	\$ (16,749.12)	BASKETBALL - GIRLS
145 L 00000 000 000 15000 807	\$ (438.35)	\$ 2,911.10	\$ 3,447.00	\$ (974.25)	BETA CLUB
145 L 00000 001 000 15000 915	\$ -	\$ -	\$ -	\$ -	BIOLOGY
145 L 00000 001 000 15000 916	\$ (64.45)	\$ -	\$ -	\$ (64.45)	BIOLOGY - BARR
145 L 00000 000 000 15000 734	\$ (116.25)	\$ -	\$ -	\$ (116.25)	BIOLOGY - CARR
145 L 00000 001 000 15000 917	\$ (923.47)	\$ -	\$ -	\$ (923.47)	BIOLOGY - FEATHERS
145 L 00000 002 000 15000 916	\$ -	\$ -	\$ -	\$ -	BIOLOGY - KIERNAN
145 L 00000 000 000 15000 735	\$ (482.07)	\$ 93.74	\$ 15.00	\$ (403.33)	BIOLOGY - KRTAUSCH
145 L 00000 000 000 15000 603	\$ (12,089.58)	\$ 32,817.62	\$ 37,696.88	\$ (16,968.84)	BLAZER ATHLETIC SUPPORT
145 L 00000 000 000 15000 970	\$ (136.64)	\$ -	\$ -	\$ (136.64)	BOARD ALLOCATION - ATTENDANCE
145 L 00000 000 000 15000 971	\$ -	\$ -	\$ -	\$ -	BOARD ALLOCATION - COPIER
145 L 00000 000 000 15000 972	\$ (3.00)	\$ -	\$ -	\$ (3.00)	BOARD ALLOCATION - MATERIALS
145 L 00000 000 000 15000 919	\$ (2,054.36)	\$ 126.00	\$ -	\$ (1,928.36)	BUILDING TRADES
145 L 00000 000 000 15000 606	\$ (9,953.03)	\$ 12,652.79	\$ 7,224.60	\$ (4,524.84)	CHEERLEADING
145 L 00000 001 000 15000 921	\$ (29.67)	\$ -	\$ -	\$ (29.67)	CHEMISTRY - CARR
145 L 00000 002 000 15000 921	\$ (236.60)	\$ -	\$ -	\$ (236.60)	CHEMISTRY - CARR
145 L 00000 000 000 15000 733	\$ (14.76)	\$ -	\$ -	\$ (14.76)	CHEMISTRY - KELLEY
145 L 00000 000 000 15000 825	\$ (1,173.00)	\$ -	\$ -	\$ (1,173.00)	CHIC FIL A ACADEMY
145 L 00000 000 000 15000 923	\$ (17,222.65)	\$ 19,070.05	\$ 10,107.00	\$ (8,259.60)	CHORUS
145 L 00000 000 000 15000 924	\$ (2,019.31)	\$ 11,803.07	\$ 14,065.00	\$ (4,281.24)	CIVIL WAR HISTORY
145 L 00000 000 000 15000 716	\$ (2,530.26)	\$ 2,532.04	\$ 8,669.00	\$ (8,667.22)	CLASS OF 2026
145 L 00000 000 000 15000 721	\$ (225.00)	\$ 2,020.63	\$ 12,445.00	\$ (10,649.37)	CLASS OF 2027
145 L 00000 000 000 15000 736	\$ (444.83)	\$ -	\$ -	\$ (444.83)	COMMUNICATIONS TECHNOLOGY
145 L 00000 000 000 15000 928	\$ (1,058.00)	\$ 50.00	\$ 310.00	\$ (1,318.00)	COSMETOLOGY
145 L 00000 000 000 15000 619	\$ (1,241.53)	\$ 600.00	\$ 1,570.00	\$ (2,211.53)	CROSS COUNTRY & TRACK
145 L 00000 000 000 15000 840	\$ (482.49)	\$ 3,579.60	\$ 3,159.50	\$ (62.39)	DANCE TEAM
145 L 00000 000 000 15000 940	\$ -	\$ -	\$ 136.00	\$ (136.00)	DIGITAL ARTS
145 L 00000 000 000 15000 929	\$ (12.93)	\$ -	\$ -	\$ (12.93)	DIVERSIFIED TECHNOLOGY
145 L 00000 000 000 15000 930	\$ (1,293.82)	\$ -	\$ 49.00	\$ (1,342.82)	DRAFTING
145 L 00000 000 000 15000 814	\$ (1,378.16)	\$ 2,284.04	\$ 4,372.00	\$ (3,466.12)	DRAMA -PLAYWRITING
145 L 00000 000 000 15000 931	\$ -	\$ -	\$ -	\$ -	DRIVERS EDUCATION
145 L 00000 000 000 15000 932	\$ (563.53)	\$ -	\$ -	\$ (563.53)	ECOLOGY
145 L 00000 000 000 15000 801	\$ (507.46)	\$ 476.00	\$ 150.00	\$ (181.46)	EDUCATORS RISING
145 L 00000 000 000 15000 933	\$ (358.71)	\$ 226.00	\$ -	\$ (132.71)	ELECTRICITY
145 L 00000 000 000 15000 710	\$ (691.39)	\$ -	\$ -	\$ (691.39)	ENGLISH
145 L 00000 000 000 15000 709	\$ (90.00)	\$ -	\$ -	\$ (90.00)	ENGLISH -CLARK
145 L 00000 000 000 15000 934	\$ (349.72)	\$ -	\$ -	\$ (349.72)	ENGLISH-709
145 L 00000 000 000 15000 737	\$ (148.36)	\$ -	\$ -	\$ (148.36)	ENVIRONMENTAL SCIENCE

145 L 00000 000 000 15000 969	\$	-	\$	-	\$	-	\$	-	EPIC
145 L 00000 000 000 15000 908	\$	(211.49)	\$	-	\$	-	\$	(211.49)	EPSO Grant
145 L 00000 000 000 15000 958	\$	(143.10)	\$	421.98	\$	314.49	\$	(35.61)	FACULTY FUND
145 L 00000 000 000 15000 935	\$	(79.10)	\$	4,173.63	\$	5,833.63	\$	(1,739.10)	FAMILY AND CONSUMER SCIENCE
145 L 00000 000 000 15000 936	\$	(645.62)	\$	-	\$	-	\$	(645.62)	FARM ACCOUNT/SHOW TEAMS
145 L 00000 000 000 15000 817	\$	(927.15)	\$	1,063.00	\$	600.00	\$	(464.15)	FCA
145 L 00000 000 000 15000 720	\$	(1,125.88)	\$	-	\$	-	\$	(1,125.88)	FCCLA II - SERVICE PROJECTS
145 L 00000 000 000 15000 819	\$	(11,508.00)	\$	13,630.87	\$	13,373.03	\$	(11,250.16)	FFA
145 L 00000 000 000 15000 821	\$	(205.40)	\$	-	\$	-	\$	(205.40)	FISHING CLUB
145 L 00000 000 000 15000 607	\$	(566.50)	\$	-	\$	-	\$	(566.50)	FOOTBALL
145 L 00000 000 000 15000 822	\$	(201.00)	\$	78.55	\$	-	\$	(122.45)	FRENCH CLUB
145 L 00000 000 000 15000 939	\$	(90.73)	\$	-	\$	-	\$	(90.73)	GEOLOGY
145 L 00000 000 000 15000 621	\$	(3,701.94)	\$	5,095.83	\$	5,445.51	\$	(4,051.62)	GIRLS SOCCER
145 L 00000 000 000 15000 818	\$	(590.38)	\$	-	\$	-	\$	(590.38)	GO-CART
145 L 00000 000 000 15000 608	\$	(12,909.53)	\$	12,121.64	\$	16,380.00	\$	(17,167.89)	GOLF
145 L 00000 000 000 15000 907	\$	(1.00)	\$	-	\$	-	\$	(1.00)	GRAD GIVES
145 L 00000 000 000 15000 906	\$	(12,200.46)	\$	802.80	\$	1,500.00	\$	(12,897.66)	GUIDANCE
145 L 00000 000 000 15000 943	\$	(19,500.38)	\$	5,042.23	\$	5,838.50	\$	(20,296.65)	HORTICULTURE
145 L 00000 000 000 15000 712	\$	(900.00)	\$	170.00	\$	100.00	\$	(830.00)	HOSA- HANNAH'S GRACE
145 L 00000 000 000 15000 826	\$	(1,840.50)	\$	16,953.62	\$	24,805.22	\$	(9,692.10)	HOSA II
145 L 00000 000 000 15000 920	\$	(40.00)	\$	-	\$	500.00	\$	(540.00)	HVAC
145 L 00000 000 000 15000 944	\$	-	\$	-	\$	-	\$	-	INFORMATION TECHNOLOGY
145 L 00000 000 000 15000 827	\$	(1,552.75)	\$	-	\$	-	\$	(1,552.75)	INTERNATIONAL CLUB
145 L 00000 001 000 15000 946	\$	(108,304.25)	\$	18,069.67	\$	61,345.77	\$	(151,580.35)	JROTC - MISCELLANEOUS
145 L 00000 002 000 15000 946	\$	-	\$	-	\$	-	\$	-	JROTC - OFFICERS
145 L 00000 005 000 15000 903	\$	(48.82)	\$	-	\$	-	\$	(48.82)	JROTC GRANT
145 L 00000 000 000 15000 828	\$	(537.38)	\$	3,854.85	\$	3,551.75	\$	(234.28)	KEY CLUB
145 L 00000 000 000 15000 948	\$	(2,021.33)	\$	-	\$	-	\$	(2,021.33)	KEYBOARDING
145 L 00000 000 000 15000 962	\$	(336.86)	\$	-	\$	10.00	\$	(346.86)	LIBRARY
145 L 00000 000 000 15000 806	\$	(7,526.85)	\$	13,188.63	\$	12,705.00	\$	(7,043.22)	MARKETING EDUCATION
145 L 00000 002 000 15000 950	\$	(474.00)	\$	90.00	\$	-	\$	(384.00)	MATH
145 L 00000 003 000 15000 950	\$	-	\$	-	\$	-	\$	-	MATH
145 L 00000 001 000 15000 950	\$	(52.36)	\$	-	\$	-	\$	(52.36)	MATH - HILL
145 L 00000 000 000 15000 955	\$	(1,687.07)	\$	-	\$	-	\$	(1,687.07)	MERCY / BENEVOLENCE FUND
145 L 00000 000 000 15000 909	\$	(0.93)	\$	-	\$	-	\$	(0.93)	MIDDLE SCHOOL BAND
145 L 00000 000 000 15000 915	\$	-	\$	-	\$	-	\$	-	MIDDLE SCHOOL BAND
145 L 00000 000 000 15000 844	\$	(34.95)	\$	-	\$	-	\$	(34.95)	MULTICULTURAL CLUB
145 L 00000 000 000 15000 832	\$	(1,288.75)	\$	-	\$	-	\$	(1,288.75)	NATIONAL HONOR SOCIETY
145 L 00000 000 000 15000 805	\$	(154.47)	\$	-	\$	-	\$	(154.47)	OUTDOOR ADVENTURE
145 L 00000 001 000 15000 912	\$	(2,627.83)	\$	-	\$	-	\$	(2,627.83)	PAUL KEYS SCHOLARSHIP
145 L 00000 000 000 15000 834	\$	(70.68)	\$	-	\$	-	\$	(70.68)	PEP CLUB
145 L 00000 000 000 15000 835	\$	-	\$	-	\$	-	\$	-	PHOTOGRAPHY CLUB
145 L 00000 001 000 15000 954	\$	(8.57)	\$	-	\$	-	\$	(8.57)	PHYSICAL SCIENCE - JENNINGS
145 L 00000 002 000 15000 954	\$	-	\$	-	\$	-	\$	-	PHYSICAL SCIENCE - RHOTON
145 L 00000 000 000 15000 957	\$	(371.28)	\$	-	\$	-	\$	(371.28)	PHYSICS
145 L 00000 003 000 15000 903	\$	-	\$	-	\$	-	\$	-	QUEST GRANT (RHOTON)
145 L 00000 000 000 15000 986	\$	(699.87)	\$	-	\$	-	\$	(699.87)	RESOURCE CDC
145 L 00000 000 000 15000 925	\$	-	\$	-	\$	-	\$	-	ROTC RANGE IMPROVEMENT GRANT
145 L 00000 003 000 15000 912	\$	(10,846.82)	\$	124.03	\$	2,800.00	\$	(13,522.79)	ROTC SCHOLARSHIP
145 L 00000 000 000 15000 841	\$	(194.37)	\$	-	\$	-	\$	(194.37)	RURI-TEEN CLUB
145 L 00000 000 000 15000 912	\$	(7,450.00)	\$	-	\$	-	\$	(7,450.00)	SCHOLARSHIPS
145 L 00000 000 000 15000 968	\$	(1,000.13)	\$	-	\$	-	\$	(1,000.13)	SCHOOL INCENTIVES
145 L 00000 001 000 15000 981	\$	(268.39)	\$	100.00	\$	-	\$	(168.39)	SCIENCE - CARR
145 L 00000 000 000 15000 982	\$	-	\$	-	\$	-	\$	-	SCIENCE DEPARTMENT GRANT
145 L 00000 000 000 15000 810	\$	-	\$	-	\$	-	\$	-	SCIENCE OLYMPIAD
145 L 00000 000 000 15000 981	\$	(10.00)	\$	-	\$	-	\$	(10.00)	SCIENCE-716-HORN
145 L 00000 000 000 15000 715	\$	(261.09)	\$	289.98	\$	300.00	\$	(271.11)	SCIENCE-HORN
145 L 00000 000 000 15000 850	\$	(21,520.01)	\$	765.00	\$	2,447.52	\$	(23,202.53)	SCRIB ACCOUNT
145 L 00000 000 000 15000 921	\$	(1,414.00)	\$	6,559.40	\$	7,753.00	\$	(2,607.60)	SKILLS
145 L 00000 000 000 15000 610	\$	(79.66)	\$	-	\$	-	\$	(79.66)	SOCCER
145 L 00000 000 000 15000 983	\$	(226.12)	\$	-	\$	-	\$	(226.12)	SOCIAL STUDIES - ECONOMICS
145 L 00000 000 000 15000 984	\$	(16.09)	\$	-	\$	-	\$	(16.09)	SOCIAL STUDIES - GOVERNMENT
145 L 00000 000 000 15000 609	\$	(7,666.22)	\$	8,861.73	\$	18,985.77	\$	(17,790.26)	SOFTBALL

145 L 00000 000 000 15000 922	\$	-	\$	-	\$	-	\$	-	SONGWRITING
145 L 00000 000 000 15000 843	\$	(510.06)	\$	-	\$	-	\$	(510.06)	SPANISH CLUB
145 L 00000 000 000 15000 977	\$	(7.22)	\$	498.37	\$	669.00	\$	(177.85)	SPECIAL EDUCATION
145 L 00000 000 000 15000 845	\$	(225.02)	\$	1,058.80	\$	1,735.00	\$	(901.22)	STUDENT COUNCIL
145 L 00000 000 000 15000 991	\$	(3,421.70)	\$	1,091.19	\$	100.00	\$	(2,430.51)	STUDENT NEEDS
145 L 00000 000 000 15000 927	\$	(295.00)	\$	100.00	\$	140.00	\$	(335.00)	TAP
145 L 00000 000 000 15000 618	\$	-	\$	-	\$	-	\$	-	TRACK
145 L 00000 000 000 15000 847	\$	(37.82)	\$	-	\$	-	\$	(37.82)	TRI M MUSIC HONOR SOCIETY
145 L 00000 000 000 15000 848	\$	(2,701.56)	\$	2,625.04	\$	2,532.12	\$	(2,608.64)	TSA
145 L 00000 000 000 15000 611	\$	(9,216.91)	\$	21,041.21	\$	21,199.29	\$	(9,374.99)	VOLLEYBALL
145 L 00000 000 000 15000 798	\$	(124,444.37)	\$	6,936.73	\$	134.89	\$	(117,642.53)	WANDA B DUGGER TRUST-BIOLOGY
145 L 00000 000 000 15000 799	\$	(122,909.91)	\$	9,931.10	\$	-	\$	(112,978.81)	WANDA B DUGGER TRUST-CHEMISTRY
145 L 00000 000 000 15000 612	\$	-	\$	750.46	\$	2,225.00	\$	(1,474.54)	WRESTLING
145 L 00000 000 000 15000 899	\$	(40,854.58)	\$	12,902.89	\$	300.00	\$	(28,251.69)	YEARBOOK

Total L-Account Balances \$ (767,005.76)

Total A-Account Balances \$ 829,752.00

Unreconciled Total Unrestricted Funds \$ 62,746.24

DCHS Chart of Accounts
L-Accounts are Restricted Accounts
4/27/2026

Account Number

Fnd T Acct Obj Prj Loc Prg	Beginning Balance	Debit Amount	Credit Amount	Ending Balance	Account Level Description
145 A 00000 000 000 16000 100	\$ 609,541.73	\$ 599,979.71	\$ 620,906.80	\$ 588,614.64	CASH IN BANK - CHECKING

Account Number

Fnd T Acct Obj Prj Loc Prg	Beginning Balance	Debit Amount	Credit Amount	Ending Balance	Account Level Description
145 L 00000 000 000 16000 904	\$ (37.88)	\$ -	\$ -	\$ (37.88)	ADVANCED COMPOSITION
145 L 00000 000 000 16000 809	\$ (116.00)	\$ -	\$ -	\$ (116.00)	AGRICULTURAL MECHANICS
145 L 00000 000 000 16000 907	\$ -	\$ -	\$ -	\$ -	ANNUAL BANQUET FUND
145 L 00000 000 000 16000 803	\$ (20.00)	\$ -	\$ -	\$ (20.00)	ARK CLUB
145 L 00000 000 000 16000 913	\$ (16,113.56)	\$ 3,279.19	\$ 3,600.00	\$ (16,434.37)	ART
145 L 00000 000 000 16000 600	\$ (38,023.24)	\$ 166,303.56	\$ 169,970.67	\$ (41,690.35)	ATHLETICS
145 L 00000 000 000 16000 620	\$ (667.95)	\$ 7,273.78	\$ 15,396.28	\$ (8,790.45)	ATHLETICS - MIDDLE SCHOOL
145 L 00000 000 000 16000 602	\$ (2,594.67)	\$ -	\$ -	\$ (2,594.67)	ATHLETICS - RESERVE
145 L 00000 000 000 16000 617	\$ (440.00)	\$ -	\$ -	\$ (440.00)	ATHLETICS - SPECIAL PROJECTS
145 L 00000 000 000 16000 614	\$ (5,305.21)	\$ 2,113.55	\$ 4,291.00	\$ (7,482.66)	ATHLETICS - TRAINING
145 L 00000 000 000 16000 804	\$ (5,282.99)	\$ 5,710.47	\$ 5,268.00	\$ (4,840.52)	AUDIO VISUAL
145 L 00000 000 000 16000 806	\$ (2,105.50)	\$ 1,594.30	\$ 930.00	\$ (1,441.20)	AUTO MECHANICS
145 L 00000 000 000 16000 914	\$ (1,273.12)	\$ 18,919.15	\$ 18,289.58	\$ (643.55)	BAND
145 L 00000 000 000 16000 604	\$ (534.00)	\$ 380.00	\$ 150.00	\$ (304.00)	BASEBALL
145 L 00000 000 000 16000 605	\$ (12,685.22)	\$ 55,299.35	\$ 55,427.63	\$ (12,813.50)	BASKETBALL - BOYS
145 L 00000 001 000 16000 605	\$ -	\$ -	\$ -	\$ -	BASKETBALL - BOYS
145 L 00000 000 000 16000 603	\$ -	\$ -	\$ -	\$ -	BASKETBALL - FRESHMAN BOYS
145 L 00000 003 000 16000 605	\$ -	\$ -	\$ -	\$ -	BASKETBALL - FRESHMAN BOYS
145 L 00000 000 000 16000 615	\$ (8,044.55)	\$ 9,414.02	\$ 7,477.42	\$ (6,107.95)	BASKETBALL - GIRLS
145 L 00000 002 000 16000 605	\$ -	\$ -	\$ -	\$ -	BASKETBALL - GIRLS
145 L 00000 002 000 16000 615	\$ -	\$ -	\$ -	\$ -	BASKETBALL - GIRLS
145 L 00000 000 000 16000 807	\$ (1,208.19)	\$ 554.00	\$ 581.00	\$ (1,235.19)	BETA CLUB
145 L 00000 000 000 16000 808	\$ (200.68)	\$ -	\$ -	\$ (200.68)	BIBLE CLUB
145 L 00000 000 000 16000 970	\$ (322.12)	\$ -	\$ -	\$ (322.12)	BOARD ALLOCATION - ATTENDANCE
145 L 00000 000 000 16000 971	\$ (7,120.69)	\$ 585.58	\$ -	\$ (6,535.11)	BOARD ALLOCATION - COPIER
145 L 00000 000 000 16000 972	\$ (1,500.00)	\$ -	\$ -	\$ (1,500.00)	BOARD ALLOCATION - MATERIALS
145 L 00000 000 000 16000 811	\$ (793.06)	\$ -	\$ 1,222.00	\$ (2,015.06)	BUSINESS PROFESSIONALS OF AMER
145 L 00000 000 000 16000 606	\$ (18,560.92)	\$ 18,731.67	\$ 17,809.11	\$ (17,638.36)	CHEERLEADING
145 L 00000 000 000 16000 851	\$ (150.58)	\$ -	\$ -	\$ (150.58)	CHESS CLUB
145 L 00000 000 000 16000 857	\$ (18.65)	\$ -	\$ -	\$ (18.65)	CHICK-FIL-A ACADEMY
145 L 00000 000 000 16000 923	\$ (7,952.92)	\$ 21,047.03	\$ 18,094.73	\$ (5,000.62)	CHORUS
145 L 00000 000 000 16000 810	\$ (274.93)	\$ 4,543.34	\$ 4,991.00	\$ (722.59)	CIVINETTES
145 L 00000 000 000 16000 812	\$ -	\$ -	\$ -	\$ -	CIVINETTES
145 L 00000 000 000 16000 715	\$ -	\$ -	\$ -	\$ -	CLASS OF 2015
145 L 00000 000 000 16000 722	\$ (4,992.86)	\$ 4,790.36	\$ 6,761.00	\$ (6,963.50)	CLASS OF 2026
145 L 00000 000 000 16000 724	\$ (7,197.10)	\$ 300.00	\$ 1,753.80	\$ (8,650.90)	CLASS OF 2027
145 L 00000 000 000 16000 716	\$ (4,478.34)	\$ -	\$ -	\$ (4,478.34)	CLASS OF 2028
145 L 00000 000 000 16000 717	\$ (13,847.30)	\$ 290.00	\$ 2,055.00	\$ (15,612.30)	CLASS OF 2029
145 L 00000 000 000 16000 925	\$ (156.86)	\$ -	\$ -	\$ (156.86)	COLLEGE CORNER
145 L 00000 000 000 16000 926	\$ -	\$ -	\$ -	\$ -	COMPOSITION
145 L 00000 000 000 16000 928	\$ (3,005.74)	\$ 3,313.03	\$ 1,806.00	\$ (1,498.71)	COSMETOLOGY
145 L 00000 000 000 16000 619	\$ (7,635.66)	\$ 18,526.62	\$ 16,844.06	\$ (5,953.10)	CROSS COUNTRY
145 L 00000 000 000 16000 621	\$ (1,670.21)	\$ 677.74	\$ 1,902.00	\$ (2,894.47)	DANCE TEAM
145 L 00000 000 000 16000 839	\$ -	\$ -	\$ -	\$ -	DCHS GEARHEADS
145 L 00000 000 000 16000 813	\$ (4,933.62)	\$ 680.21	\$ 605.00	\$ (4,858.41)	DECA
145 L 00000 000 000 16000 711	\$ (4,851.24)	\$ -	\$ -	\$ (4,851.24)	DIVERSIFIED TECHNOLOGY
145 L 00000 000 000 16000 930	\$ (5,247.26)	\$ -	\$ -	\$ (5,247.26)	DRAFTING
145 L 00000 000 000 16000 814	\$ (4,904.22)	\$ 1,148.00	\$ 144.00	\$ (3,900.22)	DRAMA CLUB
145 L 00000 000 000 16000 931	\$ (212.87)	\$ -	\$ -	\$ (212.87)	DRIVERS EDUCATION
145 L 00000 000 000 16000 826	\$ (265.00)	\$ -	\$ -	\$ (265.00)	DUNGEON & DRAGONS CLUB
145 L 00000 000 000 16000 805	\$ (247.41)	\$ 1,672.71	\$ 2,088.60	\$ (663.30)	ELECTRICAL CARPENTRY
145 L 00000 000 000 16000 830	\$ (233.67)	\$ -	\$ -	\$ (233.67)	EMR/EKG
145 L 00000 000 000 16000 934	\$ (138.71)	\$ -	\$ -	\$ (138.71)	ENGLISH

145 L 00000 000 000 16000 816	\$	(2.52)	\$	-	\$	-	\$	(2.52)	ENVIROTHON
145 L 00000 000 000 16000 969	\$	(26.89)	\$	-	\$	-	\$	(26.89)	EPIC
145 L 00000 000 000 16000 908	\$	(2,006.80)	\$	-	\$	-	\$	(2,006.80)	EPSO Grant
145 L 00000 000 000 16000 958	\$	(147.68)	\$	50.00	\$	400.00	\$	(497.68)	FACULTY FUND
145 L 00000 000 000 16000 936	\$	(166.59)	\$	-	\$	-	\$	(166.59)	FARM ACCOUNT
145 L 00000 000 000 16000 818	\$	(775.75)	\$	775.75	\$	-	\$	-	FCCLA
145 L 00000 000 000 16000 817	\$	(20,325.52)	\$	8,463.06	\$	8,091.00	\$	(19,953.46)	FELLOWSHIP OF CHRISTIAN ATHLET
145 L 00000 000 000 16000 819	\$	(4,960.48)	\$	12,956.44	\$	12,704.00	\$	(4,708.04)	FFA
145 L 00000 000 000 16000 820	\$	(25,000.00)	\$	-	\$	-	\$	(25,000.00)	FFA HORTICULTURE
145 L 00000 000 000 16000 821	\$	(10,149.71)	\$	4,619.37	\$	30.00	\$	(5,560.34)	FIRST ROBOTICS
145 L 00000 000 000 16000 607	\$	(13,912.15)	\$	44,543.72	\$	32,353.84	\$	(1,722.27)	FOOTBALL
145 L 00000 000 000 16000 822	\$	(787.87)	\$	105.00	\$	-	\$	(682.87)	FRENCH CLUB
145 L 00000 000 000 16000 801	\$	(64.87)	\$	189.00	\$	413.00	\$	(288.87)	FUTURE TEACHERS OF AMERICA
145 L 00000 000 000 16000 823	\$	(190.98)	\$	-	\$	-	\$	(190.98)	GERMAN CLUB
145 L 00000 000 000 16000 815	\$	-	\$	-	\$	-	\$	-	GO-KART
145 L 00000 000 000 16000 608	\$	(1,058.75)	\$	4,482.50	\$	3,440.00	\$	(16.25)	GOLF
145 L 00000 001 000 16000 608	\$	(39.26)	\$	-	\$	-	\$	(39.26)	GOLF - MIDDLE SCHOOL
145 L 00000 000 000 16000 910	\$	(1.00)	\$	-	\$	-	\$	(1.00)	GRAD GIVES
145 L 00000 000 000 16000 714	\$	(1,086.12)	\$	165.81	\$	607.00	\$	(1,527.31)	GRADUATION
145 L 00000 000 000 16000 940	\$	(62,431.33)	\$	26,357.23	\$	12,626.66	\$	(48,700.76)	GRAPHIC ARTS
145 L 00000 001 000 16000 940	\$	-	\$	-	\$	-	\$	-	GRAPHIC ARTS CENTRAL OFFICE
145 L 00000 000 000 16000 906	\$	(594.25)	\$	-	\$	1,020.00	\$	(1,614.25)	GUIDANCE
145 L 00000 000 000 16000 740	\$	(5,390.74)	\$	8,006.36	\$	6,651.82	\$	(4,036.20)	GUIDANCE/BENEVOLENCE
145 L 00000 000 000 16000 613	\$	(2,000.03)	\$	37,814.33	\$	35,814.30	\$	-	HARDEE'S CLASSIC/ SPECIAL TOUR
145 L 00000 000 000 16000 833	\$	(282.88)	\$	-	\$	2,000.00	\$	(2,282.88)	HARDEE'S SCHOLARSHIPS
145 L 00000 000 000 16000 824	\$	(1,053.56)	\$	8,035.27	\$	11,195.00	\$	(4,213.29)	HEALTH OCCUPATIONS
145 L 00000 000 000 16000 825	\$	(400.00)	\$	-	\$	-	\$	(400.00)	HIKING CLUB
145 L 00000 000 000 16000 942	\$	(50,592.99)	\$	25,471.21	\$	19,103.99	\$	(44,225.77)	HOME ECONOMICS
145 L 00000 000 000 16000 622	\$	-	\$	-	\$	-	\$	-	INDOOR ATHLETIC FACILTIY
145 L 00000 000 000 16000 831	\$	(539.15)	\$	84.60	\$	277.00	\$	(731.55)	INTERNATIONAL LANGUAGE CLUB
145 L 00000 000 000 16000 802	\$	(426.89)	\$	-	\$	-	\$	(426.89)	JOURNALISM
145 L 00000 000 000 16000 828	\$	(5,375.05)	\$	2,442.00	\$	4,859.00	\$	(7,792.05)	KEY CLUB
145 L 00000 000 000 16000 962	\$	(544.01)	\$	-	\$	20.00	\$	(564.01)	LIBRARY
145 L 00000 000 000 16000 947	\$	(1,685.33)	\$	1,655.52	\$	2,271.00	\$	(2,300.81)	MACHINE SHOP
145 L 00000 000 000 16000 938	\$	(7,803.29)	\$	-	\$	-	\$	(7,803.29)	MACHINE SHOP GRANT- GENE HAAS
145 L 00000 000 000 16000 949	\$	(431.29)	\$	2,414.20	\$	3,309.00	\$	(1,326.09)	MASONRY
145 L 00000 000 000 16000 950	\$	(10,495.58)	\$	59.40	\$	765.00	\$	(11,201.18)	MATH
145 L 00000 000 000 16000 616	\$	(337.50)	\$	-	\$	-	\$	(337.50)	MEN'S VOLLEYBALL
145 L 00000 000 000 16000 955	\$	(3,368.84)	\$	709.00	\$	584.00	\$	(3,243.84)	MERCY
145 L 00000 000 000 16000 951	\$	-	\$	-	\$	-	\$	-	MINI LIBRARY
145 L 00000 000 000 16000 832	\$	(129.50)	\$	270.00	\$	427.00	\$	(286.50)	MYTHS & LEGENDS
145 L 00000 000 000 16000 742	\$	(2,938.03)	\$	-	\$	100.00	\$	(3,038.03)	NEEDY STUDENT FUND
145 L 00000 000 000 16000 953	\$	(311.05)	\$	-	\$	-	\$	(311.05)	NORTHEAST SECONDARY PRINCIPALS
145 L 00000 000 000 16000 911	\$	(1,400.00)	\$	-	\$	-	\$	(1,400.00)	PARTNERS IN CAREER TECH EDUCAT
145 L 00000 000 000 16000 834	\$	(256.60)	\$	256.60	\$	-	\$	-	PEP CLUB
145 L 00000 000 000 16000 835	\$	(30.02)	\$	-	\$	-	\$	(30.02)	PHOTO CLUB
145 L 00000 000 000 16000 623	\$	-	\$	-	\$	75.00	\$	(75.00)	PICKLEBALL CLUB
145 L 00000 000 000 16000 836	\$	(2,216.36)	\$	36,345.77	\$	36,132.20	\$	(2,002.79)	PIONEER ATHLETICS CLUB
145 L 00000 000 000 16000 856	\$	(267.24)	\$	845.04	\$	2,931.93	\$	(2,354.13)	PIONEER PLAYERS
145 L 00000 000 000 16000 960	\$	(189.11)	\$	-	\$	-	\$	(189.11)	PRE-VOCATIONAL
145 L 00000 000 000 16000 956	\$	(3,396.97)	\$	655.27	\$	2,000.00	\$	(4,741.70)	PRINCIPAL'S INCENTIVE
145 L 00000 000 000 16000 965	\$	-	\$	-	\$	-	\$	-	PROJECT STAR
145 L 00000 000 000 16000 838	\$	(230.00)	\$	-	\$	-	\$	(230.00)	RADIO CLUB
145 L 00000 000 000 16000 829	\$	(655.74)	\$	-	\$	-	\$	(655.74)	RECYCLE CLUB
145 L 00000 001 000 16000 977	\$	(4,604.69)	\$	4,725.66	\$	3,030.00	\$	(2,909.03)	ROTC - MISCELLANEOUS
145 L 00000 002 000 16000 978	\$	-	\$	-	\$	-	\$	-	ROTC - MISCELLANEOUS
145 L 00000 001 000 16000 978	\$	(18,920.22)	\$	40,877.55	\$	38,708.13	\$	(16,750.80)	ROTC - OFFICERS
145 L 00000 000 000 16000 979	\$	(520.69)	\$	-	\$	-	\$	(520.69)	RURITAN
145 L 00000 000 000 16000 842	\$	(100.00)	\$	-	\$	-	\$	(100.00)	SCHOLARS BOWL
145 L 00000 000 000 16000 912	\$	(95.00)	\$	-	\$	-	\$	(95.00)	SCHOLARSHIPS
145 L 00000 000 000 16000 981	\$	(5,982.57)	\$	4,228.81	\$	4,811.00	\$	(6,564.76)	SCIENCE
145 L 00000 000 000 16000 855	\$	(961.91)	\$	1,863.59	\$	2,987.71	\$	(2,086.03)	SCRIB ACCOUNT
145 L 00000 000 000 16000 843	\$	(325.58)	\$	122.45	\$	-	\$	(203.13)	SENIOR SECTION LEADERS

145 L 00000 000 000 16000 849	\$	(5,059.38)	\$	12,347.56	\$	11,159.07	\$	(3,870.89)	SKILLS USA
145 L 00000 001 000 16000 610	\$	(1,148.32)	\$	660.00	\$	-	\$	(488.32)	SOCCER - BOYS
145 L 00000 002 000 16000 610	\$	(5,959.53)	\$	5,568.35	\$	5,690.00	\$	(6,081.18)	SOCCER - GIRLS
145 L 00000 000 000 16000 710	\$	(1,516.63)	\$	39.42	\$	410.00	\$	(1,887.21)	SOCIAL STUDIES
145 L 00000 000 000 16000 609	\$	(5,043.07)	\$	8,013.87	\$	4,980.00	\$	(2,009.20)	SOFTBALL
145 L 00000 000 000 16000 985	\$	(1,617.20)	\$	1,010.50	\$	2,175.00	\$	(2,781.70)	SPANISH
145 L 00000 000 000 16000 827	\$	(411.29)	\$	194.26	\$	-	\$	(217.03)	SPANISH HONOR SOCIETY
145 L 00000 000 000 16000 601	\$	(218.90)	\$	-	\$	-	\$	(218.90)	STAR WALK OF FAME
145 L 00000 000 000 16000 845	\$	(1,418.85)	\$	2,942.60	\$	4,112.45	\$	(2,588.70)	STUDENT COUNCIL
145 L 00000 000 000 16000 992	\$	-	\$	-	\$	-	\$	-	STUDENT OF THE MONTH
145 L 00000 000 000 16000 997	\$	(538.82)	\$	-	\$	-	\$	(538.82)	TITLE READING
145 L 00000 000 000 16000 618	\$	(4,049.44)	\$	4,798.33	\$	10,477.25	\$	(9,728.36)	TRACK
145 L 00000 000 000 16000 858	\$	-	\$	-	\$	-	\$	-	TSA - TECHNOLOGY STUDENT ASSOC
145 L 00000 000 000 16000 837	\$	-	\$	-	\$	-	\$	-	TURNING POINT USA
145 L 00000 000 000 16000 611	\$	(1,107.70)	\$	1,056.94	\$	1,473.00	\$	(1,523.76)	VOLLEYBALL
145 L 00000 000 000 16000 999	\$	(1,454.71)	\$	4,654.87	\$	5,125.00	\$	(1,924.84)	WELDING
145 L 00000 002 000 16000 912	\$	(1,455.24)	\$	-	\$	-	\$	(1,455.24)	WLC
145 L 00000 000 000 16000 612	\$	(65.86)	\$	6,834.45	\$	8,300.56	\$	(1,531.97)	WRESTLING
145 L 00000 001 000 16000 612	\$	-	\$	-	\$	-	\$	-	WRESTLING - MIDDLE SCHOOL
145 L 00000 000 000 16000 899	\$	(14,020.17)	\$	4,601.32	\$	2,408.00	\$	(11,826.85)	YEARBOOK
145 L 00000 000 000 16000 850	\$	(7.50)	\$	-	\$	-	\$	(7.50)	YOGA CLUB

Total L-Account Balances \$ (502,490.39)
Total A-Account Balances \$ 588,614.64

Unreconciled Total Unrestricted Funds \$ 86,124.25

School	Date of Trip	Location of Trip
DBHS	4/24/2026	ETSU Career Quest
BCES	5/15/2026	The Johnson City Library and the Terrarium Store
FBES	4/25/2026	Union HS
SSES	4/25/2026	Union HS
DBHS	4/28/2026	Boones Creek Elementary
GES	4/29/2026	East Tennessee Historical Museum
DCHS	4/17/2026	Gray Fairgrounds
DBHS	5/12/2026	Ridgeview School, Gray School, Sulphur Springs School, Fall Branch School
LES	4/17/2026	David Crockett High School
WVES	5/15/2026	Quantum Leap (Johnson City) and Willow Springs Park
BCES	5/8/2026	Just Jump/ Wing deer park
DCHS	5/4/2026	Oak Ridge National Laboratory (ORNL in Oak Ridge TN)
RVES	5/11/2026	Washington County Public Library - Gray Branch
DCHS	4/10/2026	Downtown Jonesborough for Governor Bill Lee visit.
DBHS	4/10/2026	Jonesborough Court House
DBHS	5/7/2026	Dollywood, Pigeon Forge, TN
JES	4/10/2026	Old Courthouse, Jonesborough, Governor Lee visit
DCHS	4/15/2026	Local 538 Union Hall
GES	5/18/2026	Sycamore Shoals State Historic Park
BCES	5/19/2026	Brights Zoo
JES	5/18/2026	Just Jump
FBES	5/7/2026	Bays Mountain
SCES	5/4/2026	Tiebreakers Johnson City , TN
GVES	5/6/2026	Quantum Leap Trampoline Sports Arena
LES	5/8/2026	Jackson Theatre and Depot Street Park
GES	4/25/2026	TSSBDA Concert Festival (Union HS TN) and trip to West Town Mall (Knoxville, TN)
RVES	4/25/2026	TSSBDA Concert Festival (Union HS TN) and trip to West Town Mall (Knoxville, TN)
DCHS	5/11/2026 [1]	Tie Breakers
GES	5/15/2026	Andrew Johnson Historical Site
FBES	5/14/2026	Wallabies of Johnson City, 3102 Hanover Road Johnson City TN 37604

WVES	5/1/2026	David Crockett High School
JES	5/13/2026	Wallabies - 3102 Hanover Rd, Johnson City, TN 37604
WVES	4/17/2026	David Crockett High School
DCHS	4/24/2026	McKinney Center for Catering
SSES	5/18/2026	Paradise Acres
LES	5/7/2026	Bristol Caverns, 1157 Bristol Caverns Hwy, Bristol, TN 37620
BCES	5/20/2026	Brights Zoo
DCHS	4/23/2026	Local Fire and Police Departments and DCHS feeder schools
DCHS	4/22/2026	Tri-cities Academy of Aesthetics
DBHS	5/15/2026	ETSU mini dome
DCHS	5/11/2026	WCC - Morristown Campus
WVES	5/19/2026	Quantum Leap and then to Willow Springs Park
DBHS	5/14/2026	3201 Hanover Road Jhonson City TN. 37604
JES	5/14/2026	_Just Jump_ in Johnson City then to Food Court and back to school
Asbury	4/24/2026	East Tennessee State University - Career Quest; 1276 Gilbreath Dr, Johnson City, TN 37614
SCES	5/7/2026	Hands On Museum and Persimmon Ridge for lunch
WVES	5/13/2026	Bays Mountain Park and Planetarium
GVES	5/6/2026	Quantum Leap
GVES	5/7/2026	Greeneville Airport, Hardin Park
DBHS	5/1/2026	D.P. Culp Center at ETSU in Johnson City, TN
WVES	5/1/2026	Lamar Alexander Rocky Fork State Park
DBHS	5/4/2026	DollyWood
DBHS	5/19/2026	Grayson Highlands State Park, VA
SSES	5/4/2026	Bristol Caverns, Bristol TN
DBHS	5/11/2026	First Watch 1150 W State of Franklin Rd Johnson City, TN 37604
DCHS	5/11/2026	TCAT, Salon Centirc, Mall for lunch
DCHS	5/21/2026	Dollywood
DBHS	5/8/2026	Poblano's
BCES	5/7/2026	TCAT boones creek and park for lunch
RVES	5/1/2006	Tiebreakers in Johnson City

JES	5/8/2026	Tipton-Haynes Historic Site
BCES	5/19/2026	Quantum Leap
BCES	5/15/2026	Warrior's Path Park
FBES	5/4/2026	Putt Putt Fun Center, Kingsport, TN 346 W Stone Dr, Kingsport, TN 37660 Pizza Plus Fall Branch 408 TN-93, Fall Branch, TN 37656
DBHS	5/15/2026	ETSU (Graduation Practice) & Cracker Barrel (Boones Creek - Breakfast)
FBES	5/6/2026	Barter Theater, Abingdon VA
GES	5/14/2026	Quantum Leap
Asbury	5/1/2026	Johnson City/Washington County Chamber of Commerce, 602 Sevier St #101, Johnson City, TN 37604
DCHS	5/13/2026	Feeder Schools
DCHS	5/1/2026	Northeast State
GES	5/13/2026	Holiday Lanes and Winged Deer Park
LES	5/4/2026	DCHS
SCES	5/11/2026 [2]	Civitan Park 1000 N. Broadway, Johnson City, TN [3]
WVES	5/12/2026	Gray Fossil Site - Hands on Discovery Center
JES	5/4/2026	David Crockett High School
JES	5/19/2026	Brights Zoo
DBHS	5/13/2026	Lunch
RVES	5/7/2026	Daniel Boone High School- for Middle School Sports Physicals
FBES	5/7/2026	DBHS

[1] Responder updated this value.

[2] Responder updated this value.

[3] Responder updated this value.

PURCHASING DEPARTMENT
WASHINGTON COUNTY BOARD OF EDUCATION

Purchase Order **№ 7378**
 Date Issued **2/24/2026**
 Appropriation No. **72250399**
 Dept. **TRANSPORTATION**
 School

PURCHASE ORDER

TO **SHI**

Deliver to **TRANSPORTATION Department**
 Address

Via

Articles on this order must be charged to account of

NOTICE TO VENDOR

1. Purchase order **MUST** bear two signatures in order to be valid.
2. Purchase order number **MUST** appear on all invoices submitted for payment.
3. Mail **TWO** copies of your invoice promptly to:

Washington County Board of Education
 405 West College Street
 Jonesborough, TN 37659
 Telephone (423) 753-1105

ARTICLES OR SERVICES	CODE	QUANTITY & UNIT	UNIT PRICE	TOTAL
(Unless otherwise stated all prices F.O.B. Destination) Bus Right Suite License (w) modules 05-01-26 to 06-30-26				
* Sourcewell Contract # 121923-SHI-*				
GRAND TOTAL - INCLUDING ALL ATTACHED PAGES				\$22,247.20

SUBJECT TO THE FOLLOWING CONDITIONS

1. All packages, cartons or other containers must be plainly marked with the purchase order number.
2. The right is reserved to purchase in the open market and to charge the difference to the Vendor in the event that deliveries are not made at the time specified in the bid and on this order.
3. Whenever a delivery is rejected, the Vendor shall be notified and be given the reason for the rejection. All rejected deliveries shall be held at the Vendor's risk and he shall bear the expense of removal.
4. Acceptance of this order includes acceptance of all terms, prices, delivery, instructions, specifications and conditions stated.
5. The county is not liable for Federal excise tax or state sales tax.
6. Each shipment and/or each purchase order should be covered by separate invoice.

IMPORTANT: INVOICES AND PACKAGES MUST BEAR PURCHASE ORDER NUMBER

VENDOR'S COPY

There is an otherwise unincumbered balance to the credit of the proper appropriation, allotment or fund to meet the expenditure covered by this purchase.

Authorized Signature

APPROVED:

Purchasing Agent



Pricing Proposal
 Quotation #: 27148383
 Created On: 2/9/2026
 Valid Until: 2/27/2026

TN-Washington County Schools

PSI - Sr. Inside Account Executive - Named

Jarrold Adams
 405 W College St
 Jonesborough, TN 37659
 United States
 Phone: (423) 753-1100
 Fax:
 Email: adamsj@wcde.org

Mike Mottola
 290 Davidson Ave.
 Somerset, NJ 08873
 Phone: 732-584-8351
 Fax: 732-564-8363
 Email: Mike_Mottola@shi.com

All Prices are in US Dollar (USD)

Product	Qty	Your Price	Total
1 BusRight Suite License - Software, Samsung Tab Active 5 tablets, all ancillary hardware, cellular service, and mounting kits included. Implementation and ongoing service support included. BusRight - Part#: NPN-BUSRI-BRSL Contract Name: Sourcewell- Technology Products & Solutions Contract #: 121923-SHI Coverage Term: 5/1/2026 – 6/30/2026 Note: Two Months	90	\$183.33	\$16,499.70
2 Additional Mount BusRight - Part#: NPN-BUSRI-ADD-MOUNT Contract Name: Sourcewell- Technology Products & Solutions Contract #: 121923-SHI Coverage Term: 5/1/2026 – 6/30/2026 Note: Two Months	29	\$27.50	\$797.50
3 Safety Pass Module - Includes cellular service, unlimited cards, and terminal readers. Implementation and ongoing service support included. BusRight - Part#: NPN-BUSRI-SAFE-PASS Contract Name: Sourcewell- Technology Products & Solutions Contract #: 121923-SHI Coverage Term: 5/1/2026 – 6/30/2026 Note: Two Months	90	\$55.00	\$4,950.00
Total			\$22,247.20

Additional Comments

This quote represents a two-month subscription, covering 5/1/26 - 6/30/26. This short-term contract will precede the 3yr annualized subscription agreement spanning 7/1/26 - 6/30/29.

Sourcewell Flow-Down Terms:

BusRight acknowledges and agrees that all applicable flow-down terms and conditions of Sourcewell Contract 121923-SHI, including but not limited to the Participating Entity's rights related to termination of orders for non-appropriation or changes in law, shall govern this quotation. In the event of any conflict or inconsistency between the terms of this quote and the terms of

Sourcewell Contract 121923-SHI, the Sourcewell contract shall control and supersede. To ensure full compliance with Sourcewell requirements, all automatic renewal provisions, renewal buffers, or similar terms have been removed. Any termination, cancellation, or renewal rights not expressly permitted under Sourcewell Contract 121923-SHI are deemed inapplicable to this quote.

Thank you for choosing SHI International Corp! The pricing offered on this quote proposal is valid through the expiration date listed above. To ensure the best level of service, please provide End User Name, Phone Number, Email Address and applicable Contract Number when submitting a Purchase Order. For any additional information including Hardware, Software and Services Contracts, please contact an SHI Inside Sales Representative at (888) 744-4084. SHI International Corp. is 100% Minority Owned, Woman Owned Business. TAX ID# 22-3009648; DUNS# 61-1429481; CCR# 61-243957G; CAGE 1HTF0

The products offered under this proposal are resold in accordance with the terms and conditions of the Contract referenced under that applicable line item.



Pricing Proposal
 Quotation #: 27148383
 Created On: 2/9/2026
 Valid Until: 5/15/2026

TN-Washington County Schools

PSI - Sr. Inside Account Executive - Named

Jarrold Adams
 405 W College St
 Jonesborough, TN 37659
 United States
 Phone: (423) 753-1100
 Fax:
 Email: adamsj@wcde.org

Mike Mottola
 290 Davidson Ave.
 Somerset, NJ 08873
 Phone: 732-584-8351
 Fax: 732-564-8363
 Email: Mike_Mottola@shi.com

All Prices are in US Dollar (USD)

Product	Qty	Your Price	Total
1 BusRight Suite License - Software, Samsung Tab Active 5 tablets, all ancillary hardware, cellular service, and mounting kits included. Implementation and ongoing service support included. BusRight - Part#: NPN-BUSRI-BRSL Contract Name: Sourcewell- Technology Products & Solutions Contract #: 121923-SHI Coverage Term: 5/1/2026 – 6/30/2026 Note: Two Months	90	\$183.33	\$16,499.70
2 Additional Mount BusRight - Part#: NPN-BUSRI-ADD-MOUNT Contract Name: Sourcewell- Technology Products & Solutions Contract #: 121923-SHI Coverage Term: 5/1/2026 – 6/30/2026 Note: Two Months	29	\$27.50	\$797.50
3 Safety Pass Module - Includes cellular service, unlimited cards, and terminal readers. Implementation and ongoing service support included. BusRight - Part#: NPN-BUSRI-SAFE-PASS Contract Name: Sourcewell- Technology Products & Solutions Contract #: 121923-SHI Coverage Term: 5/1/2026 – 6/30/2026 Note: Two Months	90	\$55.00	\$4,950.00
Total			\$22,247.20

Additional Comments

This quote represents a two-month subscription, covering 5/1/26 - 6/30/26. This short-term contract will precede the 3yr annualized subscription agreement spanning 7/1/26 - 6/30/29.

Sourcewell Flow-Down Terms:

BusRight acknowledges and agrees that all applicable flow-down terms and conditions of Sourcewell Contract 121923-SHI, including but not limited to the Participating Entity's rights related to termination of orders for non-appropriation or changes in law, shall govern this quotation. In the event of any conflict or inconsistency between the terms of this quote and the terms of

Sourcewell Contract 121923-SHI, the Sourcewell contract shall control and supersede. To ensure full compliance with Sourcewell requirements, all automatic renewal provisions, renewal buffers, or similar terms have been removed. Any termination, cancellation, or renewal rights not expressly permitted under Sourcewell Contract 121923-SHI are deemed inapplicable to this quote.

Thank you for choosing SHI International Corp! The pricing offered on this quote proposal is valid through the expiration date listed above. To ensure the best level of service, please provide End User Name, Phone Number, Email Address and applicable Contract Number when submitting a Purchase Order. For any additional information including Hardware, Software and Services Contracts, please contact an SHI Inside Sales Representative at (888) 744-4084. SHI International Corp. is 100% Minority Owned, Woman Owned Business. TAX ID# 22-3009648; DUNS# 61-1429481; CCR# 61-243957G; CAGE 1HTF0

The products offered under this proposal are resold in accordance with the terms and conditions of the Contract referenced under that applicable line item.

Request for Taxpayer Identification Number and Certification

Go to www.irs.gov/FormW9 for instructions and the latest information.

Give form to the
 requester. Do not
 send to the IRS.

Before you begin. For guidance related to the purpose of Form W-9, see *Purpose of Form*, below.

Print or type. See Specific Instructions on page 3.	<p>1 Name of entity/individual. An entry is required. (For a sole proprietor or disregarded entity, enter the owner's name on line 1, and enter the business/disregarded entity's name on line 2.)</p> <p>SHI International Corp.</p>	
	<p>2 Business name/disregarded entity name, if different from above.</p>	
	<p>3a Check the appropriate box for federal tax classification of the entity/individual whose name is entered on line 1. Check only one of the following seven boxes.</p> <p> <input type="checkbox"/> Individual/sole proprietor <input type="checkbox"/> C corporation <input checked="" type="checkbox"/> S corporation <input type="checkbox"/> Partnership <input type="checkbox"/> Trust/estate <input type="checkbox"/> LLC. Enter the tax classification (C = C corporation, S = S corporation, P = Partnership) Note: Check the "LLC" box above and, in the entry space, enter the appropriate code (C, S, or P) for the tax classification of the LLC, unless it is a disregarded entity. A disregarded entity should instead check the appropriate box for the tax classification of its owner. <input type="checkbox"/> Other (see instructions) </p>	<p>4 Exemptions (codes apply only to certain entities, not individuals; see instructions on page 3):</p> <p>Exempt payee code (if any) _____</p> <p>Exemption from Foreign Account Tax Compliance Act (FATCA) reporting code (if any) _____</p> <p style="text-align: right;"><i>(Applies to accounts maintained outside the United States.)</i></p>
	<p>3b If on line 3a you checked "Partnership" or "Trust/estate," or checked "LLC" and entered "P" as its tax classification, and you are providing this form to a partnership, trust, or estate in which you have an ownership interest, check this box if you have any foreign partners, owners, or beneficiaries. See instructions _____ <input type="checkbox"/></p>	
	<p>5 Address (number, street, and apt. or suite no.). See instructions.</p> <p>290 Davidson Avenue</p>	<p>Requester's name and address (optional)</p>
	<p>6 City, state, and ZIP code</p> <p>Somerset, NJ 08873</p>	
	<p>7 List account number(s) here (optional)</p>	

Part I Taxpayer Identification Number (TIN)

Enter your TIN in the appropriate box. The TIN provided must match the name given on line 1 to avoid backup withholding. For individuals, this is generally your social security number (SSN). However, for a resident alien, sole proprietor, or disregarded entity, see the instructions for Part I, later. For other entities, it is your employer identification number (EIN). If you do not have a number, see *How to get a TIN*, later.

Social security number									
OR									
Employer identification number									
2	2	-	3	0	0	9	6	4	8

Note: If the account is in more than one name, see the instructions for line 1. See also *What Name and Number To Give the Requester* for guidelines on whose number to enter.

Part II Certification

Under penalties of perjury, I certify that:

1. The number shown on this form is my correct taxpayer identification number (or I am waiting for a number to be issued to me); and
2. I am not subject to backup withholding because (a) I am exempt from backup withholding, or (b) I have not been notified by the Internal Revenue Service (IRS) that I am subject to backup withholding as a result of a failure to report all interest or dividends, or (c) the IRS has notified me that I am no longer subject to backup withholding; and
3. I am a U.S. citizen or other U.S. person (defined below); and
4. The FATCA code(s) entered on this form (if any) indicating that I am exempt from FATCA reporting is correct.

Certification instructions. You must cross out item 2 above if you have been notified by the IRS that you are currently subject to backup withholding because you have failed to report all interest and dividends on your tax return. For real estate transactions, item 2 does not apply. For mortgage interest paid, acquisition or abandonment of secured property, cancellation of debt, contributions to an individual retirement arrangement (IRA), and, generally, payments other than interest and dividends, you are not required to sign the certification, but you must provide your correct TIN. See the instructions for Part II, later.

Sign Here	Signature of U.S. person <i>Amy Nizam</i>	Date <i>01/14/26</i>
------------------	---	----------------------

General Instructions

Section references are to the Internal Revenue Code unless otherwise noted.

Future developments. For the latest information about developments related to Form W-9 and its instructions, such as legislation enacted after they were published, go to www.irs.gov/FormW9.

What's New

Line 3a has been modified to clarify how a disregarded entity completes this line. An LLC that is a disregarded entity should check the appropriate box for the tax classification of its owner. Otherwise, it should check the "LLC" box and enter its appropriate tax classification.

New line 3b has been added to this form. A flow-through entity is required to complete this line to indicate that it has direct or indirect foreign partners, owners, or beneficiaries when it provides the Form W-9 to another flow-through entity in which it has an ownership interest. This change is intended to provide a flow-through entity with information regarding the status of its indirect foreign partners, owners, or beneficiaries, so that it can satisfy any applicable reporting requirements. For example, a partnership that has any indirect foreign partners may be required to complete Schedules K-2 and K-3. See the Partnership Instructions for Schedules K-2 and K-3 (Form 1065).

Purpose of Form

An individual or entity (Form W-9 requester) who is required to file an information return with the IRS is giving you this form because they

PURCHASING DEPARTMENT
WASHINGTON COUNTY BOARD OF EDUCATION

Purchase Order **№ 7790**

Date Issued **2/25/26**

Appropriation No. **141E7110042901**

Dept. **Acad. (Tutoring Innov. Grant)**

School **District**

PURCHASE ORDER

TO

Benchmark Educ. Co.
 Deliver to **Cindy Hayes - Washington Cty**
 Address **405 W College Street Schools**
 Via **Jonesborough, TN 37659**

NOTICE TO VENDOR

1. Purchase order **MUST** bear two signatures in order to be valid.
2. Purchase order number **MUST** appear on all invoices submitted for payment.
3. Mail **TWO** copies of your invoice promptly to:

Washington County Board of Education
 405 West College Street
 Jonesborough, TN 37659
 Telephone (423) 753-1105

Articles on this order must be charged to account of

ARTICLES OR SERVICES (Unless otherwise stated all prices F.O.B. Destination)	CODE	QUANTITY & UNIT	UNIT PRICE	TOTAL
Decodable Readers Theater Kits See Quote 92199				\$10,800
Less Discount				< \$11,000
Shipping				\$686
GRAND TOTAL - INCLUDING ALL ATTACHED PAGES				\$10,486

SUBJECT TO THE FOLLOWING CONDITIONS

1. All packages, cartons or other containers must be plainly marked with the purchase order number.
2. The right is reserved to purchase in the open market and to charge the difference to the Vendor in the event that deliveries are not made at the time specified in the bid and on this order.
3. Whenever a delivery is rejected, the Vendor shall be notified and be given the reason for the rejection. All rejected deliveries shall be held at the Vendor's risk and he shall bear the expense of removal.
4. Acceptance of this order includes acceptance of all terms, prices, delivery, instructions, specifications and conditions stated.
5. The county is not liable for Federal excise tax or state sales tax.
6. Each shipment and/or each purchase order should be covered by separate invoice.

IMPORTANT: INVOICES AND PACKAGES MUST BEAR PURCHASE ORDER NUMBER

VENDOR'S COPY

There is an otherwise unincumbered balance to the credit of the proper appropriation, allotment or fund to meet the expenditure covered by this purchase.

Authorized Signature

APPROVED:

Purchasing Agent

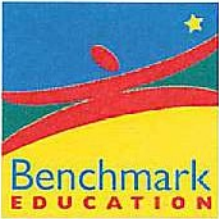

BENCHMARK EDUCATION COMPANY LLC

145 Huguenot Street, 8th Floor
New Rochelle New York 10801
Phone: 1-877-236-2465

Page	Customer #	Invoice #
1	B00993500	595824
PO Date	Invoice Date	Ship Date
3/18/2026	3/18/2026	3/17/2026
SO #	Due Date	
343932	4/17/2026	



343932

INVOICE

Sold To:

Cindy Hayes, Chief Academic Officer
Washington County Schools
405 West College Street
Jonesborough TN 37659
United States

Ship To

Cindy Hayes
Cindy Hayes
Washington County Warehouse
306 1/2 Forest Drive
Jonesborough TN 37659
United States

Customer PO#	Sales Rep	Shipped Via	Carrier	Terms
35718	E 0 2 0 8 1 Templeton	Angie UPS Ground		Net 30

Memo: mastersp@wcde.org, hayesc@wcde.org

Code	Title	List Price	Qty	BO	Extension
Y70527	Decodable Reader's Theater Gr. 3 Set	\$360.00	10		\$3,600.00
Y70528	Decodable Reader's Theater Gr. 4 Set	360.00	10		3,600.00
Y70529	Decodable Reader's Theater Gr. 5 Set	360.00	10		3,600.00

AMOUNT TO PAY	\$10,486.00
----------------------	--------------------

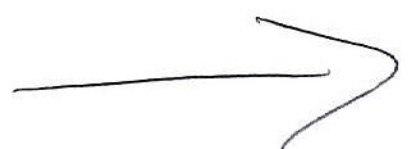

Tracking Number(s): 945782762

For questions about your order, please contact us at orderconcerns@benchmarkeducation.com. Please reference your sales order number. Paying by check remit payment to: Benchmark Education Company 145 Huguenot Street New Rochelle NY, 10801 8th Floor. Remittance email: finance@benchmarkeducation.com. Remit payment by ACH to: Valley Bank Routing#: 021201383 Account#: 42015693 (include invoice# in transmission). Remittance email: finance@benchmarkeducation.com.

Product Total	Sales Tax	S & H	Discount Total	Invoice Total	Amount Paid
\$10,800.00	\$0.00	\$686.00	(\$1,000.00)	\$10,486.00	\$0.00

PURCHASE CHECK STAMP
WASHINGTON COUNTY BOARD OF EDUCATION
 Received by *Allyson* Date *3/23/26*
 Approved For Payment by *C Hayes*
 Date Approved *3/24/26*
 Ref ID *141E-21100429-011*



011

- [ePlan Home](#)
- [Search](#)
- [Reports](#)
- [Inbox](#)
- [Planning](#)
- [Monitoring](#)
- [Funding](#)
- [Data and Information](#)
- [Reimbursement Requests](#)
- [Project Summary](#)
- [LEA Document Library](#)
- [Address Book](#)
- [TDOE Resources](#)
- [Help for Current Page](#)
- [Contact TDOE](#)
- [ePlan Sign Out](#)

Budget Overview

Washington County (900) Public District - FY 2026 - TN Tutoring Grant Application - Rev 1 - Tutoring Innovation Grant

Go To

Filter by Location: All - \$74,600.00
[Show Unbudgeted Categories](#)

Line Item Number	Account Number	71109 - Regular Instruction Program	72210 - Support Services/Regular Instruction Program	Total
189 - Other Salaries & Wages		0.00	51,840.00	51,840.00
196 - In-Service Training			1,452.00	1,452.00
201 - Social Security		0.00	3,215.00	3,215.00
204 - State Retirement		0.00	6,400.00	6,400.00
207 - Medical Insurance		0.00	750.00	750.00
429 - Instructional Supplies & Materials		10,943.00		10,943.00
Total		10,943.00	63,657.00	74,600.00
			Adjusted Allocation	74,600.00
			Remaining	0.00

141E 72210-189-000-00000-011

Go To

Hale, Brad

Production *

Session Timeout
(Hide Timer)
00:29:56

[TN.gov Directory](#) | [Web Policies](#) | [Accessibility](#)

TN Department of Education | Andrew Johnson Tower | 710 James Robertson Parkway | Nashville, TN 37243 | (629) 395-4684 | ePlan.Help@tn.gov

**PURCHASING DEPARTMENT
WASHINGTON COUNTY BOARD OF EDUCATION**

Purchase Order **No 7845**
 Date Issued **4/22/2024**
 Appropriation No. **72620336**
 Dept. **mtnce**
 School

PURCHASE ORDER

TO **TRANE**

Deliver to
 Address
 Via

NOTICE TO VENDOR

1. Purchase order **MUST** bear two signatures in order to be valid.
2. Purchase order number **MUST** appear on all invoices submitted for payment.
3. Mail **TWO** copies of your invoice promptly to:

Washington County Board of Education
 405 West College Street
 Jonesborough, TN 37659
 Telephone (423) 753-1105

Articles on this order must be charged to account of

ARTICLES OR SERVICES (Unless otherwise stated all prices F.O.B. Destination)	CODE	QUANTITY & UNIT	UNIT PRICE	TOTAL
HVAC Units		2	\$ 18,754 ⁰⁰	\$ 37,508 ⁰⁰
* OMNIA Cooperative Pricing - Racine #3341 *				
GRAND TOTAL - INCLUDING ALL ATTACHED PAGES				\$ 37,508 ⁰⁰

SUBJECT TO THE FOLLOWING CONDITIONS

1. All packages, cartons or other containers must be plainly marked with the purchase order number.
2. The right is reserved to purchase in the open market and to charge the difference to the Vendor in the event that deliveries are not made at the time specified in the bid and on this order.
3. Whenever a delivery is rejected, the Vendor shall be notified and be given the reason for the rejection. All rejected deliveries shall be held at the Vendor's risk and he shall bear the expense of removal.
4. Acceptance of this order includes acceptance of all terms, prices, delivery, instructions, specifications and conditions stated.
5. The county is not liable for Federal excise tax or state sales tax.
6. Each shipment and/or each purchase order should be covered by separate invoice.

IMPORTANT: INVOICES AND PACKAGES MUST BEAR PURCHASE ORDER NUMBER

VENDOR'S COPY

There is an otherwise unincumbered balance to the credit of the proper appropriation, allotment or fund to meet the expenditure covered by this purchase.

Authorized Signature

APPROVED:

Purchasing Agent



Proposal

Proposal is valid for 90 days.

Customer must obtain credit approval and release order to production within 60 days of proposal date.

**PROPRIETARY AND CONFIDENTIAL PROPERTY OF Trane U.S. Inc.
DISTRIBUTION TO OTHER THAN THE NAMED RECIPIENT IS PROHIBITED**

Prepared For: All Bidders

Date: April 2, 2026

Job Name:

Washington County Board of Education

Proposal Number: J3-34579-2967-1

Opportunity ID: 8583825

Delivery Terms:

Freight Allowed and Prepaid - F.O.B. Factory

COOP Quote Number: J3-210773-26-001

COOP or Federal Contract ID: OMNIA Racine #3341

Payment Terms: Net 30 Days

Trane U.S. Inc. is pleased to provide the following proposal for your review and approval.

Tag Data - 3 - 25 Ton Precedent Unitary Rooftop (Qty: 1)

Item	Tag(s)	Qty	Description	Model Number
A1	10 Ton	1	3 - 25 Ton Precedent Unitary Rooftops (P)	YSK120A3S0M**C0000001

Product Data - 3 - 25 Ton Precedent Unitary Rooftop

Item: A1 Qty: 1 Tag(s): 10 Ton

- DX Cooling / Gas Heat
- Standard Efficiency
- R-454B Refrigerant
- 10 Ton
- 208-230/60/3
- Symbio 700 unit controls
- Medium capacity gas heat
- 0-100% Economizer, dry bulb control
- Multi-speed motor
- Advanced Controller with BACnet communications interface
- Barometric relief (Field Installed)
- Comparative enthalpy kit (Field Installed)
- 5 year parts and labor warranty
- 10-year aluminized heat exchanger parts only warranty
- Factory Startup

Total Net Price (excluding sales tax) \$18,754.00

Trane shall have the right, at its discretion, to pass along any related increases should (1) its costs related to the manufacture, supply, and shipping for any product or service materially increase. This includes, but is not limited to, cost increases in raw materials, supplier components, labor, utilities, freight, logistics, wages and benefits, regulatory compliance, or any other event beyond Company's control and/or (2) any tariffs, taxes, levies or fees affecting, placed on or related to any product or service materially increases.

<p>Tax Status: Taxable <input type="checkbox"/> Exempt <input type="checkbox"/></p>	<p>If you are claiming an exemption from sales tax on this project, please submit a completed exemption certificate for both the jobsite location state and the state where the equipment will be delivered (if different from the jobsite). You can submit the relevant state exemption certificate at the following link: https://trane.certifytax.com/custportalas.aspx . You will receive an email indicating approval or rejection within 1-2 business days. If your exemption claim is rejected, sales tax will be billed based on the state where the equipment was delivered. For any questions, please email: financial_services-tax_department@tranetechnologies.com.</p>
---	---

Sincerely,

Unassigned

Trane U.S. Inc.

10384 Wallace Alley Street
Kingsport, TN 37663
Office Phone: (423) 224-1150

This proposal is subject to your acceptance of the attached Trane terms and conditions.

TERMS AND CONDITIONS - COMMERCIAL EQUIPMENT

"Company" shall mean Trane U.S. Inc. for sales in the United States and Trane Canada ULC for sales in Canada.

1. **Acceptance.** These terms and conditions are an integral part of Company's offer and form the basis of any agreement (the "Agreement") resulting from Company's proposal (the "Proposal") for the sale of the described commercial equipment and any ancillary services (the "Equipment"). **COMPANY'S TERMS AND CONDITIONS AND EQUIPMENT PRICES ARE SUBJECT TO PERIODIC CHANGE OR AMENDMENT.** The Proposal is subject to acceptance in writing by the party to whom this offer is made or an authorized agent ("Customer") delivered to Company within 15 days from the date of the Proposal. Prices in the Proposal are subject to change at any time upon notice to Customer. If Customer accepts the Proposal by placing an order, without the addition of any other terms and conditions of sale or any other modification, Customer's order shall be deemed acceptance of the Proposal subject to Company's terms and conditions. If Customer's order is expressly conditioned upon Company's acceptance or assent to terms and/or conditions other than those expressed herein, return of such order by Company with Company's terms and conditions attached or referenced serves as Company's notice of objection to Customer's terms and as Company's counteroffer to provide Equipment in accordance with the Proposal and the Company's terms and conditions. If Customer does not reject or object in writing to Company within 10 days, Company's counteroffer will be deemed accepted. Notwithstanding anything to the contrary herein, Customer's acceptance of the Equipment will in any event constitute an acceptance by Customer of Company's terms and conditions. This Agreement is subject to credit approval by Company. Upon disapproval of credit, Company may delay or suspend performance or, at its option, renegotiate prices and/or terms and conditions with Customer. If Company and Customer are unable to agree on such revisions, this Agreement shall be cancelled without any liability.
2. **Connected Services.** In addition to these terms and conditions, the Connected Services Terms of Service ("Connected Services Terms"), available at <https://www.trane.com/TraneConnectedServicesTerms>, as updated from time to time, are incorporated herein by reference and shall apply to the extent that Company provides Customer with Connected Services, as defined in the Connected Services Terms.
3. **Title and Risk of Loss.** All Equipment sales with destinations to Canada or the U.S. shall be made as follows: FOB Company's U.S. manufacturing facility or warehouse (full freight allowed). Title and risk of loss or damage to Equipment will pass to Customer upon tender of delivery of such to carrier at Company's U.S. manufacturing facility or warehouse.
4. **Pricing and Taxes.** Within forty-five (45) days following Customer acceptance of the Proposal without addition of any other terms and conditions of sale or any modification, Customer shall provide notification of release for immediate production at Company's factory. Prices for Equipment are subject to change at any time prior to shipment to reflect any cost increases related to the manufacture, supply, and shipping of Equipment. This includes, but is not limited to, cost increases in raw materials, supplier components, labor, utilities, freight, logistics, wages and benefits, regulatory compliance, or any other event beyond Company's control. If shipment is delayed due to Customer's actions, Company may also charge Customer with storage fees. If a release is not received within 6 months following order acceptance, Company reserves the right to cancel any order. Company shall be entitled to equitable adjustments in the contract price to reflect any cost increases as set forth above and will provide notice to Customer prior to the date for which the increased price is to be in effect for the applicable customer contract. In no event will prices be decreased. The price of Equipment does not include any present or future foreign, federal, state, or local property, license, privilege, sales, use, excise, value added, gross receipts or other like taxes or assessments. Such amounts will be itemized separately to Customer, who will make prompt payment to Company. Company will accept valid exemption documentation for such taxes and assessments from Customer, if applicable. All prices include packaging in accordance with Company's standard procedures. Charges for special packaging, crating or packing are the responsibility of Customer.
5. **Delivery and Delays.** Delivery dates are approximate and not guaranteed. Company will use commercially reasonable efforts to deliver the Equipment on or before the estimated delivery date, will notify Customer if the estimated delivery dates cannot be honored, and will deliver the Equipment and services as soon as practicable thereafter. In no event will Company be liable for any damages or expenses caused by delays in delivery.
6. **Performance.** Company shall be obligated to furnish only the Equipment described in the Proposal and in submittal data (if such data is issued in connection with the order). Company may rely on the acceptance of the Proposal and submittal data as acceptance of the suitability of the Equipment for the particular project or location. Unless specifically stated in the Proposal, compliance with any local building codes or other laws or regulations relating to specifications or the location, use or operation of the Equipment is the sole responsibility of Customer. If Equipment is tendered that does not fully comply with the provisions of this Agreement and Equipment is rejected by Customer, Company will have the right to cure within a reasonable time after notice thereof by substituting a conforming tender whether or not the time for performance has passed.
7. **Force Majeure.** Company's duty to perform under this Agreement and the Equipment prices are contingent upon the non-occurrence of an Event of Force Majeure. If the Company shall be unable to carry out any material obligation under this Agreement due to an Event of Force Majeure, this Agreement shall at Company's election (i) remain in effect but Company's obligations shall be suspended until the uncontrollable event terminates or (ii) be terminated upon 10 days' notice to Customer, in which event Customer shall pay Company for all parts of the Work furnished to the date of termination. An "Event of Force Majeure" shall mean any cause or event beyond the control of Company. Without limiting the foregoing, "Event of Force Majeure" includes: acts of God; acts of terrorism, war or the public enemy; flood; earthquake; tornado; storm; fire; civil disobedience; pandemic insurrections; riots; labor/labour disputes; labor/labour or material shortages; sabotage; restraint by court order or public authority (whether valid or invalid); and action or non-action by or inability to obtain or keep in force the necessary governmental authorizations, permits, licenses, certificates or approvals if not caused by Company; and the requirements of any applicable government in any manner that diverts either the material or the finished product to the direct or indirect benefit of the government.
8. **Limited Warranty.** Company warrants the Equipment manufactured by Company for a period of the lesser of 12 months from initial start-up or 18 months from date of shipment, whichever is less, against failure due to defects in material and manufacture and that it has the capacities and ratings set forth in Company's catalogs and bulletins ("Warranty"). **Equipment manufactured by Company that includes required start-up and sold in North America will not be warranted by Company unless Company performs the Equipment startup.** Exclusions from this Warranty include damage or failure arising from: wear and tear; corrosion, erosion, deterioration; modifications made by others to the Equipment; repairs or alterations by a party other than Company that adversely affects the stability or reliability of the Equipment; vandalism; neglect; accident; adverse weather or environmental conditions; abuse or improper use; improper installation; commissioning by a party other than Company; unusual physical or electrical or mechanical stress; operation with any accessory, equipment or part not specifically approved by Company; refrigerant not supplied by Company; and/or lack of proper maintenance as recommended by Company. Company shall not be obligated to pay for the cost of lost refrigerant or lost product. Company's obligations and liabilities under this Warranty are limited to furnishing replacement equipment or parts, at its option, FCA (Incoterms 2000) factory or warehouse (f.o.b. factory or warehouse for US domestic purposes) at Company-designated shipping point, freight-allowed to Company's warranty agent's stock location, for all non-conforming Company-manufactured Equipment (which have been returned by Customer to Company). Returns must have prior written approval by Company and are subject to restocking charge where applicable. Equipment, material and/or parts that are not manufactured by Company ("Third-Party Product(s)") are not warranted by Company and have such warranties as may be extended by the respective manufacturer. **CUSTOMER UNDERSTANDS THAT COMPANY IS NOT THE MANUFACTURER OF ANY THIRD-PARTY PRODUCT(S) AND ANY WARRANTIES, CLAIMS, STATEMENTS, REPRESENTATIONS, OR SPECIFICATIONS ARE THOSE OF THE THIRD-PARTY MANUFACTURER, NOT COMPANY AND CUSTOMER IS NOT RELYING ON ANY WARRANTIES, CLAIMS, STATEMENTS, REPRESENTATIONS, OR SPECIFICATIONS REGARDING THE THIRD-PARTY PRODUCT THAT MAY BE PROVIDED BY COMPANY OR ITS AFFILIATES, WHETHER ORAL OR WRITTEN. COMPANY MAKES NO REPRESENTATION OR WARRANTY OF ANY KIND, INCLUDING WARRANTY OF MERCHANTABILITY OR FITNESS FOR PARTICULAR PURPOSE. ADDITIONALLY, COMPANY MAKES NO REPRESENTATION OR WARRANTY OF ANY KIND REGARDING PREVENTING, ELIMINATING, REDUCING OR INHIBITING ANY MOLD, FUNGUS, BACTERIA, VIRUS, MICROBIAL GROWTH, OR ANY OTHER CONTAMINANTS (INCLUDING COVID-19 OR ANY SIMILAR VIRUS) (COLLECTIVELY, "CONTAMINANTS"), WHETHER INVOLVING OR IN CONNECTION WITH EQUIPMENT, ANY COMPONENT THEREOF, SERVICES OR OTHERWISE. IN NO EVENT SHALL COMPANY HAVE ANY LIABILITY FOR THE PREVENTION, ELIMINATION, REDUCTION OR INHIBITION OF THE GROWTH OR SPREAD OF SUCH CONTAMINANTS INVOLVING OR IN CONNECTION WITH ANY EQUIPMENT, THIRD-PARTY PRODUCT, OR ANY COMPONENT THEREOF, SERVICES OR OTHERWISE AND CUSTOMER HEREBY SPECIFICALLY ACKNOWLEDGES AND AGREES THERETO.** No warranty liability whatsoever shall attach to Company until Customer's complete order has been paid for in full and Company's liability under this Warranty shall be limited to the purchase price of the Equipment shown to be defective. Additional warranty protection is available on an extra-cost basis and must be in writing and agreed to by an authorized signatory of the Company. **EXCEPT FOR COMPANY'S WARRANTY EXPRESSLY SET FORTH HEREIN, COMPANY DOES NOT MAKE, AND HEREBY EXPRESSLY DISCLAIMS, ANY WARRANTIES, EXPRESS OR IMPLIED CONCERNING ITS PRODUCTS, EQUIPMENT OR SERVICES, INCLUDING, WITHOUT LIMITATION, ANY WARRANTY OF DESIGN, MERCHANTABILITY OR OF FITNESS FOR A PARTICULAR PURPOSE, OR OTHERS THAT ARE ALLEGED TO ARISE FROM COURSE OF DEALING OR TRADE.**
9. **Indemnity.** To the fullest extent permitted by law, Company and Customer shall indemnify, defend and hold harmless each other from any and all claims, actions, costs, expenses, damages and liabilities, including reasonable attorneys' fees, resulting from death or bodily injury or damage to real or personal property, to the extent caused by the negligence or misconduct of their respective employees or other authorized agents in connection with their activities within the scope of this Agreement. Neither party shall indemnify the other against claims, damages, expenses or liabilities to the extent attributable to the acts or omissions of the other party. If the parties are both at fault, the obligation to indemnify shall be proportional to their relative fault. The duty to indemnify will continue in full force and effect, notwithstanding the expiration or early termination hereof, with respect to any claims based on facts or conditions that occurred prior to expiration or termination.

- 10. Insurance.** Upon request, Company will furnish evidence of its standard insurance coverage. If Customer has requested to be named as an additional insured under Company's insurance policy, Company will do so but only subject to Company's manuscript additional insured endorsement under its primary Commercial General Liability policies. In no event does Company waive any rights of subrogation.
- 11. Customer Breach.** Each of the following events or conditions shall constitute a breach by Customer and shall give Company the right, without an election of remedies, to terminate this Agreement, require payment prior to shipping, or suspend performance by delivery of written notice: (1) Any failure by Customer to pay amounts when due; (2) any general assignment by Customer for the benefit of its creditors, or if Customer becomes bankrupt or insolvent or takes the benefit of any statute for bankrupt or insolvent debtors, or makes or proposes to make any proposal or arrangement with creditors, or if any steps are taken for the winding up or other termination of Customer or the liquidation of its assets, or if a trustee, receiver, or similar person is appointed over any of the assets or interests of Customer; (3) Any representation or warranty furnished by Customer in connection with this Agreement is false or misleading in any material respect when made; or (4) Any failure by Customer to perform or comply with any material provision of this Agreement. Customer shall be liable to the Company for all Equipment furnished and all damages sustained by Company (including lost profit and overhead).
- 12. Limitation of Liability. NOTWITHSTANDING ANYTHING TO THE CONTRARY, IN NO EVENT SHALL COMPANY BE LIABLE FOR ANY SPECIAL, INCIDENTAL, INDIRECT CONSEQUENTIAL, PUNITIVE, EXEMPLARY DAMAGES (INCLUDING WITHOUT LIMITATION REFRIGERANT LOSS, BUSINESS INTERRUPTION, LOST DATA, LOST REVENUE, LOST PROFITS), OR CONTAMINANTS LIABILITIES, EVEN IF A PARTY HAS BEEN ADVISED OF SUCH POSSIBLE DAMAGES OR IF SAME WERE REASONABLY FORESEEABLE AND REGARDLESS OF WHETHER THE CAUSE OF ACTION IS FRAMED IN CONTRACT, NEGLIGENCE, ANY OTHER TORT, WARRANTY, STRICT LIABILITY, OR PRODUCT LIABILITY. In no event will Company's liability in connection with the provision of products or services or otherwise under this Agreement exceed the entire amount paid to Company by Customer under this Agreement.**
- 13. CONTAMINANTS LIABILITY**
The transmission of COVID-19 may occur in a variety of ways and circumstances, many of the aspects of which are currently not known. HVAC systems, products, services and other offerings have not been tested for their effectiveness in reducing the spread of COVID-19, including through the air in closed environments. **(IN NO EVENT WILL COMPANY BE LIABLE UNDER THIS AGREEMENT OR OTHERWISE FOR ANY INDEMNIFICATION, ACTION, OR CLAIM, WHETHER BASED ON WARRANTY, CONTRACT, TORT OR OTHERWISE, FOR ANY BODILY INJURY (INCLUDING DEATH), DAMAGE TO PROPERTY, OR ANY OTHER LIABILITIES, DAMAGES OR COSTS RELATED TO CONTAMINANTS (INCLUDING THE SPREAD, TRANSMISSION, MITIGATION, ELIMINATION, OR CONTAMINATION THEREOF) (COLLECTIVELY, "CONTAMINANTS LIABILITIES") AND CUSTOMER HEREBY EXPRESSLY RELEASES COMPANY FROM ANY SUCH CONTAMINANTS LIABILITIES.**
- 14. Nuclear Liability.** In the event that the Equipment sold hereunder is to be used in a nuclear facility, Customer will, prior to such use, arrange for insurance or governmental indemnity protecting Company against all liability and hereby releases and agrees to indemnify Company and its suppliers for any nuclear damage, including loss of use, in any manner arising out of a nuclear incident, whether alleged to be due, in whole or in part to the negligence or otherwise of Company or its suppliers.
- 15. Intellectual Property; Patent Indemnity.** Company retains all ownership, license and other rights to all patents, trademarks, copyrights, trade secrets and other intellectual property rights related to the Equipment, and, except for the right to use the Equipment sold, Customer obtains no rights to use any such intellectual property. Company agrees to defend any suit or proceeding brought against Customer so far as such suit or proceeding is solely based upon a claim that the use of the Equipment provided by Company constitutes infringement of any patent of the United States of America, provided Company is promptly notified in writing and given authority, information and assistance for defense of same. Company will, at its option, procure for Customer the right to continue to use said Equipment, or modify it so that it becomes non-infringing, or replace same with non-infringing Equipment, or to remove said Equipment and to refund the purchase price. The foregoing will not be construed to include any Agreement by Company to accept any liability whatsoever in respect to patents for inventions including more than the Equipment furnished hereunder, or in respect of patents for methods and processes to be carried out with the aid of said Equipment. The provision of Equipment by Company does not convey any license, by implication, estoppel, or otherwise, under patent claims covering combinations of said Equipment with other devices or elements. The foregoing states the entire liability of Company with regard to patent infringement. Notwithstanding the provisions of this paragraph, Customer will hold Company harmless against any expense or loss resulting from infringement of patents or trademarks arising from compliance with Customer's designs or specifications or instructions.
- 16. Cancellation.** Equipment is specially manufactured in response to orders. An order placed with and accepted by Company cannot be delayed, canceled, suspended, or extended except with Company's written consent and upon written terms accepted by Company that will reimburse Company for and indemnify Company against loss and provide Company with a reasonable profit for its materials, time, labor, services, use of facilities and otherwise. Customer will be obligated to accept any Equipment shipped, tendered for delivery or delivered by Company pursuant to the order prior to any agreed delay, cancellation, suspension or extension of the order. Any attempt by Customer to unilaterally revoke, delay or suspend acceptance for any reason whatever after it has agreed to delivery of or accepted any shipment shall constitute a breach of this Agreement. For purposes of this paragraph, acceptance occurs by any waiver of inspection, use or possession of Equipment, payment of the invoice, or any indication of exclusive control exercised by Customer.
- 17. Invoicing and Payment.** Unless otherwise agreed to in writing by Company, equipment shall be invoiced to Customer upon tender of delivery thereof to the carrier. Customer shall pay Company's invoices within net 30 days of shipment date. Company reserves the right to add to any account outstanding for more than 30 days a service charge equal to the lesser of the maximum allowable legal interest rate or 1.5% of the principal amount due at the end of each month. Customer shall pay all costs (including attorneys' fees) incurred by Company in attempting to collect amounts due and otherwise enforcing these terms and conditions. If requested, Company will provide appropriate lien waivers upon receipt of payment. Company may at any time decline to ship, make delivery or perform work except upon receipt of cash payment, letter of credit, or security, or upon other terms and conditions satisfactory to Company. Customer agrees that, unless Customer makes payment in advance, Company will have a purchase money security interest in all Equipment to secure payment in full of all amounts due Company and its order for the Equipment, together with these terms and conditions, form a security agreement (as defined by the UCC in the United States and as defined in the Personal Property Security Act in Canada). Customer shall keep the Equipment free of all taxes and encumbrances, shall not remove the Equipment from its original installation point and shall not assign or transfer any interest in the Equipment until all payments due Company have been made. The purchase money security interest granted herein attaches upon Company's acceptance of Customer's order and on receipt of the Equipment described in the accepted Proposal but prior to its installation. The parties have no agreement to postpone the time for attachment unless specifically noted in writing on the accepted order. Customer will have no rights of set off against any amounts, which become payable to Company under this Agreement or otherwise.
- 18. Claims.** Company will consider claims for concealed shortages in shipments or rejections due to failure to conform to an order only if such claims or rejections are made in writing within 15 days of delivery and are accompanied by the packing list and, if applicable, the reasons in detail why the Equipment does not conform to Customer's order. Upon receiving authorization and shipping instructions from authorized personnel of Company, Customer may return rejected Equipment, transportation charges prepaid, for replacement. Company may charge Customer any costs resulting from the testing, handling, and disposition of any Equipment returned by Customer which are not found by Company to be nonconforming. All Equipment damaged during shipment and all claims relating thereto must be made with the freight carrier in accordance with such carrier's policies and procedures. Claims for Equipment damaged during shipment are not covered under the warranty provision stated herein.
- 19. Export Laws.** The obligation of Company to supply Equipment under this Agreement is subject to the ability of Company to supply such items consistent with applicable laws and regulations of the United States and other governments. Company reserves the right to refuse to enter into or perform any order, and to cancel any order, under this Agreement if Company in its sole discretion determines that performance of the transaction to which such order relates would violate any such applicable law or regulation. Customer will pay all handling and other similar costs from Company's factories including the costs of freight, insurance, export clearances, import duties and taxes. Customer will be "exporter of record" with respect to any export from the United States of America and will perform all compliance and logistics functions in connection therewith and will also comply with all applicable laws, rules and regulations. Customer understands that Company and/or the Equipment are subject to laws and regulations of the United States of America which may require licensing or authorization for and/or prohibit export, re-export or diversion of Company's Equipment to certain countries, and agrees it will not knowingly assist or participate in any such diversion or other violation of applicable United States of America laws and regulations. Customer agrees to hold harmless and indemnify Company for any damages resulting to Customer or Company from a breach of this paragraph by Customer.
- 20. General.** Except as provided below, to the maximum extent provided by law, this Agreement is made and shall be interpreted and enforced in accordance with the laws of the state of New York for Equipment shipped to a U.S. location and the laws of the province to which Equipment is shipped within Canada, without regard to its conflict of law principles that might otherwise call for the application of a different state's or province's law, and not including the United Nations Convention on Contracts for the International Sale of Goods. To the extent the Equipment is being used at a site owned and/or operated by any agency of the Federal Government, determination of any substantive issue of law shall be according to the Federal common law of Government contracts as enunciated and applied by Federal judicial bodies and boards of contract appeals of the Federal Government. This Agreement contains all of the agreements, representations and understandings of the parties and supersedes all previous understandings, commitments or agreements, oral or written, related to the subject matter hereof. This Agreement may not be amended, modified or terminated except by a writing signed by the parties hereto. No documents shall be incorporated herein by reference except to the extent Company is a signatory thereon. If any term or condition of this Agreement is invalid, illegal or incapable of being enforced by any rule of law, all other terms and conditions of this Agreement will nevertheless remain in full force and effect as long as the economic or legal substance of the transaction contemplated hereby is not affected in a manner adverse to any party hereto. Customer may not assign, transfer, or convey this Agreement, or any part hereof, or its right, title or interest herein, without the written consent of the Company. Subject to the foregoing, this Agreement shall be binding upon and inure to the benefit of Customer's permitted successors and assigns. This Agreement may be executed in several

counterparts, each of which when executed shall be deemed to be an original, but all together shall constitute but one and the same Agreement. A fully executed facsimile copy hereof or the several counterparts shall suffice as an original.

21. Federal Requirements. The Parties shall comply with all United States federal labor law obligations under 29 CFR part 471, appendix A to subpart A. THE FOLLOWING PROVISIONS ARE INCORPORATED HEREIN BY REFERENCE: Executive Order 11701 and 41 CFR §§ 60-250.5(a), 60-300.5; Executive Order 11758 and 41 CFR § 60-741.5(a); U.S. Immigration laws, including the L-1 Visa Reform Act of 2004 and the H-1B Visa Reform Act of 2004; and Executive Order 13496. The Parties shall abide by the requirements of 41 CFR 60-300.5(a) and 60-741.5(a). These regulations prohibit discrimination against qualified individuals based on their status as protected veterans or individuals with disabilities. Moreover, these regulations require that covered prime contractors and subcontractors take affirmative action to employ and advance in employment individuals without regard to protected veteran status or disability. The Parties certify that they do not operate any programs promoting DEI that violate any applicable United States anti-discrimination laws and acknowledge and agree that their compliance with all applicable federal anti-discrimination laws is material to the federal government's payment decisions. The Parties acknowledge and agree that their employment, procurement, and contracting practices shall not consider race, color, sex, sexual preference, religion, or national origin in ways that violate United States federal civil rights laws.

22. U.S. Government Work.

The following provision applies only to direct sales by Company to the US Government. The Parties acknowledge that Equipment ordered and delivered under this Agreement are Commercial Items as defined under Part 12 of the Federal Acquisition Regulation (FAR). In particular, Company agrees to be bound only by those Federal contracting clauses that apply to "commercial" suppliers and that are contained in FAR 52.212-5(e)(1).

The following provision applies only to indirect sales by Company to the US Government. As a Commercial Item Subcontractor, Company accepts only the following mandatory flow down provisions: 52.219-8; 52.222-26; 52.222-35; 52.222-36; 52.222-39; 52.247-84. If the sale of the Equipment is in connection with a U.S. Government contract, Customer certifies that it has provided and will provide current, accurate, and complete information, representations and certifications to all government officials, including but not limited to the contracting officer and officials of the Small Business Administration, on all matters related to the prime contract, including but not limited to all aspects of its ownership, eligibility, and performance. Anything herein notwithstanding, Company will have no obligations to Customer unless and until Customer provides Company with a true, correct and complete executed copy of the prime contract. Upon request, Customer will provide copies to Company of all requested written communications with any government official related to the prime contract prior to or concurrent with the execution thereof, including but not limited to any communications related to Customer's ownership, eligibility or performance of the prime contract. Customer will obtain written authorization and approval from Company prior to providing any government official any information about Company's performance of the work that is the subject of the Proposal or this Agreement, other than the Proposal or this Agreement.

23. Limited Waiver of Sovereign Immunity. If Customer is an Indian tribe (in the U.S.) or a First Nation or Band Council (in Canada), Customer, whether acting in its capacity as a government, governmental entity, a duly organized corporate entity or otherwise, for itself and for its agents, successors, and assigns: (1) hereby provides this limited waiver of its sovereign immunity as to any damages, claims, lawsuit, or cause of action (herein "Action") brought against Customer by Company and arising or alleged to arise out of the furnishing by Company of any product or service under this Agreement, whether such Action is based in contract, tort, strict liability, civil liability or any other legal theory; (2) agrees that jurisdiction and venue for any such Action shall be proper and valid (a) if Customer is in the U.S., in any state or United States court located in the state in which Company is performing this Agreement or (b) if Customer is in Canada, in the superior court of the province or territory in which the work was performed; (3) expressly consents to such Action, and waives any objection to jurisdiction or venue; (4) waives any requirement of exhaustion of tribal court or administrative remedies for any Action arising out of or related to this Agreement; and (5) expressly acknowledges and agrees that Company is not subject to the jurisdiction of Customer's tribal court or any similar tribal forum, that Customer will not bring any action against Company in tribal court, and that Customer will not avail itself of any ruling or direction of the tribal court permitting or directing it to suspend its payment or other obligations under this Agreement. The individual signing on behalf of Customer warrants and represents that such individual is duly authorized to provide this waiver and enter into this Agreement and that this Agreement constitutes the valid and legally binding obligation of Customer, enforceable in accordance with its terms.

1-26.130-4 (0225)
Supersedes 1-26.130-4(1024)

SECURITY ADDENDUM

This Addendum shall be applicable to the sale, installation and use of Trane equipment and the sale and provision of Trane services. "Trane" shall mean Trane U.S. Inc. for sales and services in the United States, or Trane Canada ULC for sales and services in Canada.

1. **Definitions.** All terms used in this Addendum shall have the meaning specified in the Agreement unless otherwise defined herein. For the purposes of this Addendum, the following terms are defined as follows:
"Customer Data" means Customer account information as related to the Services only and does not include HVAC Machine Data or personal data. Trane does not require, nor shall Customer provide personal data to Trane under the Agreement. Such data is not required for Trane to provide its Equipment and/or Services to the Customer.
"Equipment" shall have the meaning set forth in the Agreement.
"HVAC Machine Data" means data generated and collected from the product or furnished service without manual entry. HVAC Machine Data is data relating to the physical measurements and operating conditions of a HVAC system, such as but not limited to, temperatures, humidity, pressure, HVAC equipment status. HVAC Machine Data does not include Personal Data and, for the purposes of this agreement, the names of users of Trane's controls products or hosted applications shall not be Personal Data, if any such user chooses to use his/her name(s) in the created accounts within the controls product (e.g., firstname.lastname@address.com). HVAC Machine Data may be used by Trane: (a) to provide better support services and/or products to users of its products and services; (b) to assess compliance with Trane terms and conditions; (c) for statistical or other analysis of the collective characteristics and behaviors of product and services users; (d) to backup user and other data or information and/or provide remote support and/or restoration; (e) to provide or undertake: engineering analysis; failure analysis; warranty analysis; energy analysis; predictive analysis; service analysis; product usage analysis; and/or other desirable analysis, including, but not limited to, histories or trends of any of the foregoing; and (f) to otherwise understand and respond to the needs of users of the product or furnished service. **"Personal Data"** means data and/or information that is owned or controlled by Customer, and that names or identifies, or is about a natural person, such as: (i) data that is explicitly defined as a regulated category of data under any data privacy laws applicable to Customer; (ii) non-public personal information ("NPI") or personal information ("PI"), such as national identification number, passport number, social security number, social insurance number, or driver's license number; (iii) health or medical information, such as insurance information, medical prognosis, diagnosis information, or genetic information; (iv) financial information, such as a policy number, credit card number, and/or bank account number; (v) personally identifying technical information (whether transmitted or stored in cookies, devices, or otherwise), such as IP address, MAC address, device identifier, International Mobile Equipment Identifier ("IMEI"), or advertising identifier; (vi) biometric information; and/or (vii) sensitive personal data, such as, race, religion, marital status, disability, gender, sexual orientation, geolocation, or mother's maiden name.
"Security Incident" shall refer to (i) a compromise of any network, system, application or data in which Customer Data has been accessed or acquired by an unauthorized third party; (ii) any situation where Trane reasonably suspects that such compromise may have occurred; or (iii) any actual or reasonably suspected unauthorized or illegal Processing, loss, use, disclosure or acquisition of or access to any Customer Data.
"Services" shall have the meaning set forth in the Agreement.
2. **HVAC Machine Data; Access to Customer Extranet and Third Party Systems.** If Customer grants Trane access to HVAC Machine Data via web portals or other non-public websites or extranet services on Customer's or a third party's website or system (each, an "Extranet"), Trane will comply with the following:
 - a. **Accounts.** Trane will ensure that Trane's personnel use only the Extranet account(s) designated by Customer and will require Trane personnel to keep their access credentials confidential.
 - b. **Systems.** Trane will access the Extranet only through computing or processing systems or applications running operating systems managed by Trane that include: (i) system network firewalls; (ii) centralized patch management; (iii) operating system appropriate anti-malware software; and (iv) for portable devices, full disk encryption.
 - c. **Restrictions.** Unless otherwise approved by Customer in writing, Trane will not download, mirror or permanently store any HVAC Machine Data from any Extranet on any medium, including any machines, devices or servers.
 - d. **Account Termination.** Trane will terminate the account of each of Trane's personnel in accordance with Trane's standard practices after any specific Trane personnel who has been authorized to access any Extranet (1) no longer needs access to HVAC Machine Data or (2) no longer qualifies as Trane personnel (e.g., the individual leaves Trane's employment).
 - e. **Third Party Systems.** Trane will provide Customer prior notice before it uses any third party system that stores or may otherwise have access to HVAC Machine Data, unless (1) the data is encrypted and (2) the third party system will not have access to the decryption key or unencrypted "plain text" versions of the HVAC Machine Data.
3. **Customer Data; Confidentiality.** Trane shall keep confidential, and shall not access or use any Customer Data and information that is marked confidential or by its nature is considered confidential ("Customer Confidential Information") other than for the purpose of providing the Equipment and Services, and will disclose Customer Confidential Information only: (i) to Trane's employees and agents who have a need to know to perform the Services, (ii) as expressly permitted or instructed by Customer, or (iii) to the minimum extent required to comply with applicable law, provided that Trane (1) provides Customer with prompt written notice prior to any such disclosure, and (2) reasonably cooperate with Customer to limit or prevent such disclosure.
4. **Customer Data; Compliance with Laws.** Trane agrees to comply with laws, regulations governmental requirements and industry standards and practices relating to Trane's processing of Customer Confidential Information (collectively, "Laws").
5. **Customer Data; Information Security Management.** Trane agrees to establish and maintain an Information security and privacy program, consistent with applicable HVAC equipment industry practices that complies with this Addendum and applicable Laws ("**Information Security Program**"). The Information Security Program shall include appropriate physical, technical and administrative safeguards, including any safeguards and controls agreed by the Parties in writing, sufficient to protect Customer systems, and Customer's Confidential Information from unauthorized access, destruction, use, modification or disclosure. The Information Security Program shall include appropriate, ongoing training and awareness programs designed to ensure that Trane's employees and agents, and others acting on Trane's, behalf are aware of and comply with the Information Security Program's policies, procedures, and protocols.
6. **Monitoring.** Trane shall monitor and, at regular intervals consistent with HVAC equipment industry practices, test and evaluate the effectiveness of its Information Security Program. Trane shall evaluate and promptly adjust its Information Security Program in light of the results of the testing and monitoring, any material changes to its operations or business arrangements, or any other facts or circumstances that Trane knows or reasonably should know may have a material impact on the security of Customer Confidential Information, Customer systems and Customer property.
7. **Audits.** Customer acknowledges and agrees that the Trane SOC2 audit report will be used to satisfy any and all audit/inspection requests/requirements by or on behalf of Customer. Trane will make its SOC2 audit report available to Customer upon request and with a signed nondisclosure agreement.
8. **Information Security Contact.** Trane's Information security contact is Local Sales Office.
9. **Security Incident Management.** Trane shall notify Customer after the confirmation of a Security Incident that affects Customer Confidential Information, Customer systems and Customer property. The written notice shall summarize the nature and scope of the Security Incident and the corrective action already taken or planned.
10. **Threat and Vulnerability Management.** Trane regularly performs vulnerability scans and addresses detected vulnerabilities on a risk basis. Periodically, Trane engages third-parties to perform network vulnerability assessments and penetration testing. Vulnerabilities will be reported in accordance with Trane's cybersecurity vulnerability reported process. Trane periodically provides security updates and software upgrades.
11. **Security Training and Awareness.** New employees are required to complete security training as part of the new hire process and receive annual and targeted training (as needed and appropriate to their role) thereafter to help maintain compliance with Security Policies, as well as other corporate policies, such as the Trane Code of Conduct. This includes requiring Trane employees to annually re-acknowledge the Code of Conduct and other Trane policies as appropriate. Trane conducts periodic security awareness campaigns to educate personnel about their responsibilities and provide guidance to create and maintain a secure workplace.

12. **Secure Disposal Policies.** Trane will maintain policies, processes, and procedures regarding the disposal of tangible and intangible property containing Customer Confidential Information so that wherever possible, Customer Confidential Information cannot be practicably read or reconstructed.
13. **Logical Access Controls.** Trane employs internal monitoring and logging technology to help detect and prevent unauthorized access attempts to Trane's corporate networks and production systems. Trane's monitoring includes a review of changes affecting systems' handling authentication, authorization, and auditing, and privileged access to Trane production systems. Trane uses the principle of "least privilege" (meaning access denied unless specifically granted) for access to customer data.
14. **Contingency Planning/Disaster Recovery.** Trane will implement policies and procedures required to respond to an emergency or other occurrence (i.e. fire, vandalism, system failure, natural disaster) that could damage Customer Data or any system that contains Customer Data. Procedures include the following
 - (i) Data backups; and
 - (ii) Formal disaster recovery plan. Such disaster recovery plan is tested at least annually.
15. **Return of Customer Data.** If Trane is responsible for storing or receiving Customer Data, Trane shall, at Customer's sole discretion, deliver Customer Data to Customer in its preferred format within a commercially reasonable period of time following the expiration or earlier termination of the Agreement or, such earlier time as Customer requests, securely destroy or render unreadable or undecipherable each and every original and copy in every media of all Customer's Data in Trane's possession, custody or control no later than [90 days] after receipt of Customer's written instructions directing Trane to delete the Customer Data.
16. **Background Checks** Trane shall take reasonable steps to ensure the reliability of its employees or other personnel having access to the Customer Data, including the conducting of appropriate background and/or verification checks in accordance with Trane policies.
17. **DISCLAIMER OF WARRANTIES.** EXCEPT FOR ANY APPLICABLE WARRANTIES IN THE AGREEMENT, THE SERVICES ARE PROVIDED "AS IS", WITH ALL FAULTS, AND THE ENTIRE RISK AS TO SATISFACTORY QUALITY, PERFORMANCE, ACCURACY AND EFFORT AS TO SUCH SERVICES SHALL BE WITH CUSTOMER. TRANE DISCLAIMS ANY AND ALL OTHER EXPRESS OR IMPLIED REPRESENTATIONS AND WARRANTIES WITH RESPECT TO THE SERVICES AND THE SERVICES PROVIDED HEREUNDER, INCLUDING ANY EXPRESS OR IMPLIED WARRANTY OF MERCHANTABILITY, FITNESS FOR A PARTICULAR PURPOSE, OR THAT THE SERVICES WILL OPERATE ERROR-FREE OR UNINTERRUPTED OR RETURN/RESPONSE TO INQUIRIES WITHIN ANY SPECIFIC PERIOD OF TIME.

October 2024
Supersedes: November 2023v2

From Procurement to Performance

Trane's Holistic Approach to Building Efficiency



Simplify. Comply. Save.

Through OMNIA Partners, you can access Trane's comprehensive energy strategies for infrastructure improvements via a cooperative purchasing contract that helps simplify procurement, shorten timelines, and deliver tangible savings.

Complex Procurement Slows Progress

Delayed timelines, budget constraints, and lengthy processes can hinder progress when improvements are needed most. To address these issues, Trane's cooperative purchasing contracts offer a compliant purchasing model for solutions that help create more comfortable and resilient environments. Cooperative purchasing streamlines the procurement process, navigating complexities, and providing swift and efficient implementation of necessary improvements.

A Direct Path to What You Need

Together, Trane and OMNIA Partners offer access to Trane's entire portfolio of solutions through a streamlined, compliant process that accelerates timelines and removes traditional procurement roadblocks.

Leveraging Trane's contract with OMNIA Partners provides:



Streamlined
procurement
processes



Shortened
project
timelines



Pre-negotiated
pricing



More owner
control on project
implementation



Current Contracts*

Trane's competitively solicited OMNIA Partners contracts satisfy most bid requirements.



Racine County Contract
HVAC Products, Installation,
Labor Based Solutions



Region 4 Contract
Energy Solutions



Port of Portland
Energy Savings Performance
Contracting Services

* Agreements offered through OMNIA Partners, Public Sector, are competitively solicited and awarded by a public agency/governmental entity (e.g., state, city, county, public university or school district) via a thorough Request for Proposal (RFP). By utilizing a cooperative contract, agencies eliminate duplication of effort, saving valuable time, resources and money.

Providing Solutions That Deliver Results

Our holistic approach enhances building performance by helping to reduce operating costs and support long-term efficiency goals. Trane offers strategic guidance and turnkey solutions tailored to your facility's needs.

Performance Optimization	Sustainable Solutions	Renewable Energy Integration	Efficiency Improvements	Project Funding & Execution	System Upgrades
Real-time data to support improved energy system performance	Assist in reducing emissions with energy-efficient technologies	Integrate solar, wind, and energy storage systems	Identify inefficiencies and help reduce energy consumption	Secure funding and manage energy project installations	Improve infrastructure to meet modern energy standards

Whether you're upgrading a school, modernizing a municipal building, or managing multiple facility types, this cooperative purchasing contract provides a single-source solution for design, equipment, installation, and long-term support.

Eligible Facility Types

- ✓ State, County, & Local Government
- ✓ Public and Private Universities & Colleges
- ✓ K-12 School Districts
- ✓ Housing Authorities
- ✓ Airports
- ✓ Water Districts
- ✓ Non-Profits



Take the complexity out of procurement, so you can focus on what really matters—**creating better environments for the people who use your buildings every day.**

Disclaimer: This is for informational purposes only and does not constitute legal advice. Trane believes the facts and suggestions presented here to be accurate. However, final design and application decisions are your responsibility. Trane disclaims any responsibility for actions taken on the material presented.



Trane – by Trane Technologies (NYSE: TT), a global climate innovator – creates comfortable, energy efficient indoor environments through a broad portfolio of heating, ventilating and air conditioning systems and controls, services, parts and supply. For more information, please visit trane.com or tranetechnologies.com.

All trademarks referenced in this document are the trademarks of their respective owners.

© 2025 Trane. All Rights Reserved.

EDU-SLB065-EN
07/08/2025

Racine County, Wisconsin

Contract # 3341

for

**HVAC Products, Installation, Labor Based Solutions and
Related Product and Services**

with

Trane US Inc.

Effective: September 1, 2022

The following documents comprise the executed contract between the Racine County, Wisconsin and Trane U.S. Inc., effective September 1, 2022:

- I. Vendor Contract and Signature Form
- II. Supplier's Response to the IFB, incorporated by reference



HVAC PRODUCTS, INSTALLATION, LABOR BASED SOLUTIONS AND RELATED PRODUCT AND SERVICES CONTRACT 2022

This Contract made and entered into this 16th day of August 2022, by and between Racine County, Wisconsin, 730 Wisconsin Avenue, Racine, Wisconsin 53403 (hereinafter referred to as "COUNTY") and Trane U.S. Inc., 800 Beatty Street, Davidson, North Carolina 28036-6924 (hereinafter referred to as "CONTRACTOR").

WITNESSETH:

For good and valuable consideration, the parties agree as follows:

1. **WORK:** CONTRACTOR shall provide HVAC PRODUCTS, INSTALLATION, LABOR BASED SOLUTIONS AND RELATED PRODUCT AND SERVICES:

The undersigned parties understand and agree to comply with and be bound by the entire contents of Sealed Bid # RC2022-1001: HVAC PRODUCTS, INSTALLATION, LABOR BASED SOLUTIONS AND RELATED PRODUCT AND SERVICES (aka, the Contractor's Bid Proposal submitted July 21, 2022) which is incorporated herein by reference. CONTRACTOR understands and agrees that the bonds and insurance required by the Project Manual are to be kept current at all times through the length of each term and for 90 Days following completion of each term. Bonds and insurance must be renewed and presented to the COUNTY at the time of each renewal term if COUNTY chooses to renew. Bonds and insurance shall be written by a firm acceptable to the COUNTY as specified in the Project Manual.

2. **TERM:** September 1, 2022, to August 31, 2027, with full renewal of one (1) additional five (5) year term per the Project Manual. COUNTY shall exercise renewal options by issuance and delivery to CONTRACTOR of a written notice to renew this Agreement.
3. **PROJECT:** HVAC PRODUCTS, INSTALLATION, LABOR BASED SOLUTIONS AND RELATED PRODUCT AND SERVICES in accordance with the Project Manual.
4. **PRICE:** Price as stated for all schedules included in the Project Manual.

5. **CANCELLATION:** This contract may be cancelled without penalty or obligation of any kind, by COUNTY by, for or on behalf of itself or its agencies, departments, officers, agents or employees immediately upon written notice to all parties that sufficient funds have not been budgeted by the County Board of Supervisors to pay the obligations under this agreement.

Either party may terminate the contract on the anniversary date in any subsequent year of the contract by providing the other party with written notice ninety (90) days prior to the anniversary date.

If the CONTRACTOR fails to maintain and keep in force required insurance, COUNTY shall have the right to cancel and terminate the contract without notice.

Notwithstanding any of the terms and conditions contained herein, the COUNTY and CONTRACTOR reserve the right to terminate the contract at any time for any reason by providing written notice of termination to the other party no less than ninety (90) days in advance of termination. In the event of said termination, CONTRACTOR shall not reduce its activities hereunder unless agreed in advance by COUNTY. The CONTRACTOR will pay according to the contract for services tendered through the date of termination.

RACINE COUNTY

BY: DocuSigned by:
Jonathan Delagrave 8/17/2022
78876D99951B406...

BY: DocuSigned by:
Michael J. Lauzdorf 8/17/2022
38F9231CFBA8401...

BY: DocuSigned by:
Wendy Christensen 8/17/2022
FC1B3339B99548D...

BY: DocuSigned by:
Elvira Zimmer 8/16/2022
14A5582654004D4...

BY: Trane U.S. Inc. DocuSigned by:
Greg Spencer 8/16/2022
93FF4CCACB904F1...

PURCHASING DEPARTMENT
WASHINGTON COUNTY BOARD OF EDUCATION

Purchase Order **No 7862**

Date Issued **4/21/24**

Appropriation No. **41E71300429002**

Dept. **ISM**

School **GV-Heather Shelton**

PURCHASE ORDER

TO

Presentation Solutions

Deliver to **Grandview Elementary**

Address **2801 Hwy 11E**

Via **Telford, TN 37690**

Articles on this order must be charged to account of

NOTICE TO VENDOR

1. Purchase order **MUST** bear two signatures in order to be valid.
2. Purchase order number **MUST** appear on all invoices submitted for payment.
3. Mail **TWO** copies of your invoice promptly to:

Washington County Board of Education
 405 West College Street
 Jonesborough, TN 37659
 Telephone (423) 753-1105

ARTICLES OR SERVICES (Unless otherwise stated all prices F.O.B. Destination)	CODE	QUANTITY & UNIT	UNIT PRICE	TOTAL
<p>Please see quote attached...</p> <p>41E71300429002 # ISM</p> <p>41E - #</p> <p>* Buy Board Contract # 16025</p>				
GRAND TOTAL - INCLUDING ALL ATTACHED PAGES				\$17,954⁶⁰

SUBJECT TO THE FOLLOWING CONDITIONS

1. All packages, cartons or other containers must be plainly marked with the purchase order number.
2. The right is reserved to purchase in the open market and to charge the difference to the Vendor in the event that deliveries are not made at the time specified in the bid and on this order.
3. Whenever a delivery is rejected, the Vendor shall be notified and be given the reason for the rejection. All rejected deliveries shall be held at the Vendor's risk and he shall bear the expense of removal.
4. Acceptance of this order includes acceptance of all terms, prices, delivery, instructions, specifications and conditions stated.
5. The county is not liable for Federal excise tax or state sales tax.
6. Each shipment and/or each purchase order should be covered by separate invoice.

IMPORTANT: INVOICES AND PACKAGES MUST BEAR PURCHASE ORDER NUMBER

VENDOR'S COPY

There is an otherwise unincumbered balance to the credit of the proper appropriation, allotment or fund to meet the expenditure covered by this purchase.

Authorized Signature

W. Bradford

APPROVED:

Purchasing Agent

Quote

PRESENTATION SOLUTIONS
 PO BOX 159
 4809 FOX RUN ROAD
 BUCKNER, KY 40010
 (502) 222-7277

Order Number: 0094903
Order Date: 4/20/2026

Salesperson: DIV 70
Customer Number: 00-WASHTN

Sold To:

Washington County Board of Education
 ACCOUNTS PAYABLE
 405 West College St
 Jonesborough, TN 37659
Confirm To:

Ship To:

Grandview Elementary School
 Heather Shelton
 2981 Hwy 11E
 Telford, TN 37690

Customer P.O.	Ship VIA	F.O.B.	Terms			
QUOTE	UPS GROUND		NET 10			
Item Number	Unit	Ordered	Shipped	Back Order	Price	Amount
UL-STDBOND-24	EACH	6	0	0	79.15	474.90
ColorPro 24" Standard Bond Pap			Whse: 000			
UL-STDBOND-36	EACH	6	0	0	98.95	593.70
36" Standard Bond Paper, 36"x1			Whse: 000			
UL-IOV-36	EACH	5	0	0	257.35	1,286.75
Stadium Pro Indoor/Outdoor Vin			Whse: 000			
UL-WLSVR-24	EACH	4	0	0	287.05	1,148.20
Wall-Friendly Adhesive Vinyl,			Whse: 000			
UL-SCRVW-24	EACH	2	0	0	366.25	732.50
SecureView Adhesive One-Way-Vi			Whse: 000			
Special Promotion #1: Purchase 10 rolls of ColorPro paper, receive 1 roll of standard bond paper free!						
UL-STDBOND-24	EACH	2	0	0	0.00	0.00
ColorPro 24" Standard Bond Pap			Whse: 000			
UL2-INKSET-301	EACH	3	0	0	1,088.75	3,266.25
ColorPro Ultra 2 Full Ink Set			Whse: 000			
Special Promotion #2: Purchase 10 ColorPro inks, receive 1 roll of standard bond paper free!						
UL-STDBOND-24	EACH	1	0	0	0.00	0.00
ColorPro 24" Standard Bond Pap			Whse: 000			
UL-MAINCART	EACH	1	0	0	148.50	148.50
Maintenance Cartridge For Colo			Whse: 000			
UL-PH6	EACH	1	0	0	643.50	643.50
Printhead For ColorPro ULTRA			Whse: 000			
CL-FILM-300	EACH	3	0	0	296.95	890.85
CoolLam Dual-Sided Laminating			Whse: 000			
/ITEM	EACH	3	0	0	1,282.05	3,846.15
UL-DTADIUM-36						
Stadium/Gym Posters Starter Kit includes the following items.						

Continued

Quote

PRESENTATION SOLUTIONS
 PO BOX 159
 4809 FOX RUN ROAD
 BUCKNER, KY 40010
 (502) 222-7277

Order Number: 0094903
 Order Date: 4/20/2026

Salesperson: DIV 70
 Customer Number: 00-WASHTN

Sold To:

Washington County Board of Education
 ACCOUNTS PAYABLE
 405 West College St
 Jonesborough, TN 37659
 Confirm To:

Ship To:

Grandview Elementary School
 Heather Shelton
 2981 Hwy 11E
 Telford, TN 37690

Customer P.O.	Ship VIA	F.O.B.	Terms			
QUOTE	UPS GROUND		NET 10			
Item Number	Unit	Ordered	Shipped	Back Order	Price	Amount
UL-IOV-36	EACH	12	0	0	0.00	0.00
Stadium Pro Indoor/Outdoor Vin			Whse: 000			
UL-BANTABS	EACH	6	0	0	0.00	0.00
Banner Tabs, Pack of 100			Whse: 000			
UL-PUNCH	EACH	3	0	0	0.00	0.00
Banner Tabs, Punch			Whse: 000			
ID-TAPE-110C	EACH	4	0	0	89.05	356.20
ID/Recog 4" Tape, Clear, 1 rol			Whse: 000			
ID-RIB-101BK	EACH	4	0	0	148.45	593.80
ID/Recog 4" Ribbon-Black (each			Whse: 000			
ID-TAPE-112W	EACH	4	0	0	89.05	356.20
ID/Recog 4" Tape, White, 1 rol			Whse: 000			
ID-RIB-101BK	EACH	2	0	0	148.45	296.90
ID/Recog 4" Ribbon-Black (each			Whse: 000			
ID-RIB-102WH	EACH	2	0	0	148.45	296.90
ID/Recog 4" Ribbon-White (each			Whse: 000			
ID-RIB-103RD	EACH	2	0	0	148.45	296.90
ID/Recog 4" Ribbon-Red (each)			Whse: 000			
ID-RIB-104BL	EACH	2	0	0	148.45	296.90
ID/Recog 4" Ribbon-Blue (each)			Whse: 000			
ID-RIB-105NB	EACH	4	0	0	148.45	593.80
ID/Recog 4" Ribbon-Navy Blue (Whse: 000			
ID-RIB-106DG	EACH	2	0	0	148.45	296.90
ID/Recog 4" Ribbon-Dark Green			Whse: 000			
ID-RIB-107GR	EACH	2	0	0	148.45	296.90
ID/Recog 4" Ribbon-Green (each			Whse: 000			

Continued

Quote

PRESENTATION SOLUTIONS
 PO BOX 159
 4809 FOX RUN ROAD
 BUCKNER, KY 40010
 (502) 222-7277

Order Number: 0094903
 Order Date: 4/20/2026

Salesperson: DIV 70
 Customer Number: 00-WASHTN

Sold To:
 Washington County Board of Education
 ACCOUNTS PAYABLE
 405 West College St
 Jonesborough, TN 37659
Confirm To:

Ship To:
 Grandview Elementary School
 Heather Shelton
 2981 Hwy 11E
 Telford, TN 37690

Customer P.O.	Ship VIA	F.O.B.	Terms			
QUOTE	UPS GROUND		NET 10			
Item Number	Unit	Ordered	Shipped	Back Order	Price	Amount
ID-RIB-108YW	EACH	3	0	0	148.45	445.35
ID/Recog 4" Ribbon-Yellow (eac			Whse: 000			
ID-RIB-109OR	EACH	2	0	0	148.45	296.90
ID/Recog 4" Ribbon-Orange (eac			Whse: 000			
CM-BLADE	EACH	1	0	0	49.45	49.45
Blade for THE MAX Sign Cuttin			Whse: 000			

Please reference Buyboard Contract #760-25 along with the quote # on your purchase order.

Net Order:	17,504.40
Less Discount:	0.00
Freight:	450.20
Sales Tax:	0.00
Order Total:	17,954.60

PURCHASING DEPARTMENT
WASHINGTON COUNTY BOARD OF EDUCATION

Purchase Order **Nº 7894**
 Date Issued **04-22-26**
 Appropriation No. **72710453**
 Dept. **TRANSPORTATION**
 School

PURCHASE ORDER

TO
Advance Auto

Deliver to
Bus Garage

Address

Via

Articles on this order must be charged to account of

NOTICE TO VENDOR

1. Purchase order **MUST** bear two signatures in order to be valid.
2. Purchase order number **MUST** appear on all invoices submitted for payment.
3. Mail **TWO** copies of your invoice promptly to:

Washington County Board of Education
 405 West College Street
 Jonesborough, TN 37659
 Telephone (423) 753-1105

ARTICLES OR SERVICES	CODE	QUANTITY & UNIT	UNIT PRICE	TOTAL
(Unless otherwise stated all prices F.O.B. Destination)				
Propane Transfer 20X75 Evacuation System				
* Price Quotes Attached *				
GRAND TOTAL - INCLUDING ALL ATTACHED PAGES				\$ 11,710.67

SUBJECT TO THE FOLLOWING CONDITIONS

1. All packages, cartons or other containers must be plainly marked with the purchase order number.
2. The right is reserved to purchase in the open market and to charge the difference to the Vendor in the event that deliveries are not made at the time specified in the bid and on this order.
3. Whenever a delivery is rejected, the Vendor shall be notified and be given the reason for the rejection. All rejected deliveries shall be held at the Vendor's risk and he shall bear the expense of removal.
4. Acceptance of this order includes acceptance of all terms, prices, delivery, instructions, specifications and conditions stated.
5. The county is not liable for Federal excise tax or state sales tax.
6. Each shipment and/or each purchase order should be covered by separate invoice.

IMPORTANT: INVOICES AND PACKAGES MUST BEAR PURCHASE ORDER NUMBER

VENDOR'S COPY	There is an otherwise unincumbered balance to the credit of the proper appropriation, allotment or fund to meet the expenditure covered by this purchase.	APPROVED:
	Authorized Signature	

PRICE INQUIRY FORM
Washington County Schools

Vendor	Description of item for price comparison	Price Quoted
Company Slegers Address London, Ontario - CANADA - Person Contacted Kyle Date 3-3-26	20x75 Evacuation System	10,628.00
* Company Advance Auto Address W. Market St. J.C. Person Contacted Brad Date 3-30-26	20x75 Evacuation System ① Lower Price on Parts ② Closer for Service ③ No Excise Tax	11,710.67
Company N/A Address Person Contacted Date	 4/22/26	

 Name of person obtaining inquiry



Service is our best part.

Store 3330 926 W. MARKET ST. JOHNSON CITY, TN 37604 Phone: (423) 928-4521

Washington County Board of Education
1099 Shamrock Dr

Jonesborough, TN 37659
Phone: (423) 753-1105
Account ID: 1872545941

Date: 3/30/26
Register: 7

Invoice/Trans: 3330608971197
Time: 10:02:05
Delivery: Yes
Salesperson: Bradley

Product Line	Part #	Description	SKU	Warranty	Qty	List	Cost	Extended
		20X75 EVAC PUMI PROPANE TRANSFER PUMF	80010222		1	10,826.67	884.00	10,826.67
		20X75 EVAC PUMI PROPANE TR FREIGHT	80010265		1		884.00	884.00
MERCHANDISE SUBTOTAL								11,710.67
TOTAL INVOICE								11,710.67

Will Do better on pads & Rotors
and also try to on other Items as well

Bradley CPP

THANK YOU FOR YOUR BUSINESS!
PAGE 1

Customer Quote
Not a valid receipt
Prices and tax are subject to change



Engineered Products Inc.

5 Cuddy Boulevard
London, Ontario N5V 3Y3
519.685.7444 bus 519.685.2882 fax
www.sleegers.ca

To: Lynn Archer
Email: archerl@wcde.org
From: Kyle Squance
Quotation Number: QEV26008

Company: Washington County
 Department of Education
Pages: 1
Date: March 3, 2026

Below is a quotation for the following item(s):

Stock Code	Description	Order Qty	Price	UOM
20X75_EVAC SYSTEM	20X75 EVACUATION SYSTEM	1	\$9,744.00	EA
	FREIGHT – WITHOUT LIFTGATE		\$884.00	
	FREIGHT – WITH LIFTGATE		\$1,013.00	

Notes: Shipping quoted for delivery: 307 Forest Dr, Jonesborough, Tn 37659
Transit time: approximately 2-3 business days.

Delivery: ETA for Evacuation System shipping is approximately 1 to 2 weeks from time of PO

Terms: FOB SLEEGERS Engineered Products Inc. 5 Cuddy Blvd. London, Ontario, N5V 3Y3
 Payment Terms: **Due Upon Receipt**
 All taxes extra
 Quote is valid for 30 days
 Currency: USD

PURCHASING DEPARTMENT
WASHINGTON COUNTY BOARD OF EDUCATION

Purchase Order **No 7921**

Date Issued **4/27/26**

Appropriation No.

Dept. **Summer Programs**
 School **Academic District**

PURCHASE ORDER

TO Benchmark Education Co.

Deliver to **Cindy Hayes**
 Address **Washington Co Schools Warehouse**
306 1/2 Forest DR.
 Via **Jonesborough, TN 37659**

Articles on this order must be charged to account of

NOTICE TO VENDOR

1. Purchase order **MUST** bear two signatures in order to be valid.
2. Purchase order number **MUST** appear on all invoices submitted for payment.
3. Mail **TWO** copies of your invoice promptly to:

Washington County Board of Education
 405 West College Street
 Jonesborough, TN 37659
 Telephone (423) 753-1105

ARTICLES OR SERVICES	CODE	QUANTITY & UNIT	UNIT PRICE	TOTAL
(Unless otherwise stated all prices F.O.B. Destination)				
Rising Readers Club Teacher Set Grade 1 - Grade 3 (See attached)				
GRAND TOTAL - INCLUDING ALL ATTACHED PAGES				11,497.15

SUBJECT TO THE FOLLOWING CONDITIONS

1. All packages, cartons or other containers must be plainly marked with the purchase order number.
2. The right is reserved to purchase in the open market and to charge the difference to the Vendor in the event that deliveries are not made at the time specified in the bid and on this order.
3. Whenever a delivery is rejected, the Vendor shall be notified and be given the reason for the rejection. All rejected deliveries shall be held at the Vendor's risk and he shall bear the expense of removal.
4. Acceptance of this order includes acceptance of all terms, prices, delivery, instructions, specifications and conditions stated.
5. The county is not liable for Federal excise tax or state sales tax.
6. Each shipment and/or each purchase order should be covered by separate invoice.

IMPORTANT: INVOICES AND PACKAGES MUST BEAR PURCHASE ORDER NUMBER

VENDOR'S COPY

There is an otherwise unincumbered balance to the credit of the proper appropriation, allotment or fund to meet the expenditure covered by this purchase.

Authorized Signature

APPROVED:

Purchasing Agent

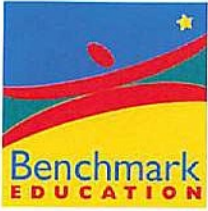

**BENCHMARK
EDUCATION
COMPANY**
145 Huguenot Street, 8th Floor
New Rochelle, New York 10801

Contact representative
E02081 Angie Templeton
Email: atempleton@benchmarkeducation.com
Office Phone:
Phone: 615-679-8020

QUOTE: 94862

Customer:

Attention: Cindy Hayes, Chief Academics Officer
Washington County Board of Education
405 West College Street
Jonesborough TN 37659
United States

Ship To:

Attention: Cindy Hayes, Chief Academics Officer
Washington Co. Schools Warehouse
306 1/2 Forest Drive
Jonesborough TN 37659

Product Code	Title	Price Level	Unit Price	Qty	Total Price
Y74779	Rising Readers Club Teacher Set Rising Grade 1	Current	\$795.00	4	\$3,180.00
Y74780	Rising Readers Club Teacher Set Rising Grade 2	Current	\$795.00	4	\$3,180.00
Y74781	Rising Readers Club Teacher Set Rising Grade 3	Current	\$795.00	3	\$2,385.00
Y74784	Rising Readers Club Student Rising Grade 1 Consumables 1-Year	Current	\$20.00	75	\$1,500.00
Y74785	Rising Readers Club Student Rising Grade 2 Consumables 1-Year	Current	\$20.00	75	\$1,500.00
Y74786	Rising Readers Club Student Rising Grade 3 Consumables 1-Year	Current	\$20.00	75	\$1,500.00

Subtotal	Discount / Gratis Product Total	Sales Tax	Shipping Cost	Total
\$13,245.00	(\$2,500.00)	\$0.00	\$752.15	\$11,497.15 USD

Memo

* TIPS Contract #230904 * Applied EOYF262: When purchasing \$10,000 - \$24,999 of product, add-on up to \$2,500 in free additional product. Shipping and handling reduced to 5%. Excludes: Benchmark Literacy, Benchmark Advance, Benchmark Adelante, RTA, Listos y Adelante, Benchmark Workshop, Benchmark Taller, PD Essentials, Individual Trade Books, Individual Reycraft Books, Custom Orders or Professional Development Training Sessions. * A temporary 2% fuel surcharge has been added to our standard Shipping and Handling charges.

- * The above pricing cannot be combined with any other offers.
- * Price valid through 5/31/2026. Price quote must be attached to school purchase orders to receive the quoted price.
- * All digital subscriptions will end on July 31st the last year of the term purchased.
- * Any changes, including cancellations to the originally agreed upon PD trainings, must be made at least 10 business days prior to the delivery of the PD trainings. Customized PD changes must be submitted at least 15 business days prior to agreed delivery date and must go through the customized request process. Benchmark Education will do its best to accommodate the requested changes; however, it reserves the right to render services according to the initial agreement. Please note that any changes requested may incur an additional charge or reduction of number of PD training days rendered. Please note that no changes can be requested on site and all requests must go through the Company approval process.

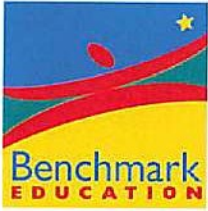

**BENCHMARK
EDUCATION
COMPANY**
145 Huguenot Street, 8th Floor
New Rochelle, New York 10801

Contact representative
E02081 Angie Templeton
Email: atempleton@benchmarkeducation.com
Office Phone:
Phone: 615-679-8020

QUOTE: 94862

PLEASE INCLUDE THIS PROPOSAL WITH YOUR PURCHASE ORDER ALONG WITH THE FOLLOWING INFORMATION

- Billing Contact Name
- Billing Contact Email
- Billing Contact Phone

PLEASE INCLUDE THE FOLLOWING INFORMATION FOR ALL DIGITAL SUBSCRIPTIONS

- Name of School(s) That Will Use the Subscription(s)
Attach separate document if necessary

- Onboarding Tech Contact Name
- Onboarding Tech Contact E-Mail

- REQUIRED

SEND ORDER TO: Benchmark Education Company
6295 Commerce Center Drive, Suite B| Groveport, OH 43125-1160
Email: neworders@benchmarkeducation.com
Phone: 877-236-2465| Fax: 877-732-8273

Terms of Service

* By placing an order for Benchmark Education Company ("BEC") products (the "Products"), the entity ("Customer") that this proposal has been prepared for agrees to be bound by BEC's Terms of Service and Terms of Use and Privacy Policy (Please visit this site: <https://help.benchmarkuniverse.com/bubateacher/Content/Customer%20Support/Privacy%20Policy.htm?Highlight=privacy>). Subject to the Customer's payment of the fees set out above, BEC grants to Customer a non-exclusive and non-transferable license to access and use the Products under the terms described in this Terms of Service. The proposal contains the scope of use allowed and the term of Customer's license to the Products.

PURCHASING DEPARTMENT
WASHINGTON COUNTY BOARD OF EDUCATION

Purchase Order **No 7922**

Date Issued **4/27/06**

Appropriation No.

Dept. **Summer Programs**
Academic
 School **Dept. District**

PURCHASE ORDER

TO **TCM**

Deliver to **Cindy Hayes**
 Address **Washington Co Schools**

Via

Articles on this order must be charged to account of

NOTICE TO VENDOR

1. Purchase order **MUST** bear two signatures in order to be valid.
2. Purchase order number **MUST** appear on all invoices submitted for payment.
3. Mail **TWO** copies of your invoice promptly to:

Washington County Board of Education
 405 West College Street
 Jonesborough, TN 37659
 Telephone (423) 753-1105

ARTICLES OR SERVICES	CODE	QUANTITY & UNIT	UNIT PRICE	TOTAL
(Unless otherwise stated all prices F.O.B. Destination) Take Home Literacy Backpacks for K-8 (see attached)				
GRAND TOTAL - INCLUDING ALL ATTACHED PAGES				29,337.19

SUBJECT TO THE FOLLOWING CONDITIONS

1. All packages, cartons or other containers must be plainly marked with the purchase order number.
2. The right is reserved to purchase in the open market and to charge the difference to the Vendor in the event that deliveries are not made at the time specified in the bid and on this order.
3. Whenever a delivery is rejected, the Vendor shall be notified and be given the reason for the rejection. All rejected deliveries shall be held at the Vendor's risk and he shall bear the expense of removal.
4. Acceptance of this order includes acceptance of all terms, prices, delivery, instructions, specifications and conditions stated.
5. The county is not liable for Federal excise tax or state sales tax.
6. Each shipment and/or each purchase order should be covered by separate invoice.

IMPORTANT: INVOICES AND PACKAGES MUST BEAR PURCHASE ORDER NUMBER

VENDOR'S COPY

There is an otherwise unincumbered balance to the credit of the proper appropriation, allotment or fund to meet the expenditure covered by this purchase.

Authorized Signature

APPROVED:

Purchasing Agent

Teacher Created Materials

5482 Argosy Ave
Huntington Beach, CA 92649



Created by Teachers for Teachers and Students

Proposal For:
Washington County School District
Proposal #: **TCM-00107351**
Attn: **Cindy Hayes**

Issued By: **Brooke Clark**
Email: **brooke.clark@tcmpub.com**
Direct Line: **(661) 904-3859**
Issue Date: **April 27, 2026**

Billing Address:
Washington County Schools
405 W College St.
Jonesborough, TN 37659

Shipping Address:
Washington County Schools
Attn: Ms. Cindy Hayes
405 W College St.
Jonesborough, TN 37659

Item	Title	Notes:	Qty	Sales Price	Total
130780	Take-Home Backpack: Pre-K-K		60	\$54.99	\$3,299.40
130785	Take-Home Backpack: Grades K-1		80	\$54.99	\$4,399.20
130786	Take-Home Backpack: Grades 1-2		80	\$54.99	\$4,399.20
130787	Take-Home Backpack: Grades 2-3		75	\$54.99	\$4,124.25
130788	Take-Home Backpack: Grades 3-4		65	\$54.99	\$3,574.35
130789	Take-Home Backpack: Grades 4-5		45	\$54.99	\$2,474.55
130790	Take-Home Backpack: Grades 5-6		35	\$54.99	\$1,924.65
130791	Take-Home Backpack: Grades 6-7		30	\$54.99	\$1,649.70
130792	Take-Home Backpack: Grades 7-8		15	\$54.99	\$824.85
				Subtotal:	\$26,670.15
TIPS: 210902				Shipping:	\$2,667.04
Buyboard: 653-21				Sales Tax:	\$0.00
Please remit orders to: Orders@tcmpub.com or Fax: 888-877-7606				Total:	\$29,337.19

Safety Disclaimer

This proposal may contain items not developed or manufactured by or under the direction of TCM. We take seriously the safety ramifications of all our products and will pass along all risk warnings provided by the manufacturers of products not developed by TCM. Such risks may include, but are not limited to, suffocation, strangulation, choking, and exposure to sharp objects. Please follow all safety precautions which may include, but are not limited to, keeping hazardous items out of reach, avoiding using cords or strings in risky environments, supervising children when using small parts to prevent choking, and handling sharp objects with care. By proceeding, you accept the risks of any liability, and agree to indemnify, defend, and hold harmless TCM from any liability, including all related fees and costs, for any claim of injury or damage resulting from the alleged improper use or oversight of any products not developed or manufactured by TCM, and from potential risks or side effects that may result from the foreseeable use of any products not developed or manufactured by TCM.

Washington County Board of Education

Monitoring: Review: Annually	Descriptor Term: Student Fees and Fines	Descriptor Code: 6.709	Issued Date: 01/14/21
		Rescinds: 6.709	Issued: 09/05/13

1 School fees are defined as follows:¹

- 2 1. Fees for activities that occur during regular school hours;
- 3 2. Fees for activities and supplies required to participate in all courses offered for credit or grade;
- 4 3. Fees or tuition applicable to courses taken during the summer by a student, except that non-
- 5 resident students regularly enrolled in another school system may be required to pay fees for
- 6 such summer courses; and
- 7 4. Fees required for graduation ceremonies.

8 No fees or tuitions shall be required of any student as a condition of attending school or using its
9 equipment while receiving educational training. All school fees must be authorized by the board of
10 education. The Board will determine activities during the school day and supplies that are required for
11 participation in courses offered for credit or grade for which the board authorizes the request of fees.

12 Upon board authorization, the following school fees may be requested from but not required of any
13 student, regardless of financial status (including eligibility for free or reduced price lunch);

- 14 1. Fees for activities that occur during regular school hours, including field trips, any portion of
15 which fall within the school day; or for activities outside regular school hours if required for
16 credit or grade;
- 17 2. Fees for activities and supplies required to participate in all courses offered for credit or grade,
18 including interscholastic athletics and marching band if taken for credit in accordance with
19 board policy.
- 20 3. Refundable security deposits collected by a school for use of school property for courses
21 offered for credit or grade, including interscholastic athletics and marching band if taken for
22 credit in accordance with board policy.

23 The board waives the following fees for students eligible for free or reduced price school lunches:

- 24 1. Fees or tuition applicable for courses taken for credit or grade during the summer.
- 25 2. Fees required for graduation.

26 Fee waiver process for students eligible for free or reduced price lunch:

27 At the beginning of each school year, at the time of enrollment, and/or at the time of requesting student
28 fees, all students and their parents or legal guardians shall be given clear and prominent written notice
29 of authorized fees that may be requested and notice of the fee waiver process. The parent(s) or legal
30 guardian(s) shall be given the opportunity to pay all or any portion of the school fee if they desire.
31 However, if the parents(s) choose not to pay the fee, the child may not be prevented from participating
32 in the activity or course for which the fee is being requested. Written notice to parents or legal

1 guardians of approval or denial of requests for fee waivers will be provided. Any denial shall contain
2 the specific grounds for denial and shall afford the parent or legal guardian the opportunity for a
3 personal meeting with the appropriate school personnel to discuss the validity of the denial. The office
4 of the director of schools shall maintain copies of any forms, notices, and/or instructions used by
5 schools in the waiver of fees and shall keep records of any denials, appeals of denials, and resolution of
6 such appeals.

7 Schools are authorized by the Board to require payment of the following fees by all affected students:

- 8 1. Fines imposed on all students for late-returned library books; parking or other traffic fines
9 imposed for abuse of parking privileges on school property; or reasonable charges for lost or
10 destroyed textbooks, library books, workbooks, or other property of the school;
- 11 2. Debts incurred to the school;
- 12 3. Refundable security deposits collected by a school for use of school property for participation
13 in extracurricular activities;
- 14 4. Costs for extracurricular activities occurring outside the regular school day including sports,
15 optional trips, clubs, or social events.

16 Schools are authorized by the Board to withhold all grade cards, diplomas, certificates of progress, or
17 transcripts for a student who has taken property which belongs to a local education agency, or has
18 incurred a debt to the school, until such student makes restitution in full. Unpaid school fees, as
19 defined above, may not be considered debts owed to the school.

20 **FINES²**

21 The director of schools shall develop procedures regarding the assessing and collections of fines for the
22 destruction or damage of school property. Such procedures shall comply with all state laws and
23 regulations.

Legal References

1. TCA 49-2-114; TRR/MS 0520-01-02-.16
2. TCA 37-10-101, 102

Cross References

Revenues 2.400
Textbooks and Instructional Materials 4.400
Graduation Activities 4.606
Care of School Property 6.311

Washington County Department of Education
School Educational **OVERNIGHT** Trip Authorization*



Date of Request 04/07/2026 School David Crockett Trip Date May 31-June 6, 2026

Estimated time of departure May 31st 2pm and return June 6th 2pm total time away 7days 6 nights

Destination (include location) Atlanta Georgia, Courtland Grand Hotel/ Georgia Convention Center

Teacher Mr. Lewis, Mr. Tipton Class Electrical, Graphic Arts Grade 11-12

Chaperones Chantel Lewis, Mr. Lewis

Number of Students Involved 4

Mr. Tipton

Estimated Total Miles (both ways) of Trip 650

Bus Driver/Number N/A Bus Driver/ Number N/A

Will Chaperones have a list (roll) that they are responsible for? Yes

As you plan the trip, will all children be given instructions as to what they should do if they become separated (lost) from the group? Yes

Will you have on file parental release forms signed by parents or legal guardians? Yes

Explain the educational value of the trip: SkillsUSA National Leadership/Skills Conference. Students will compete in trade skills and network with future employers and post secondary education

Total Cost Estimate \$9,000

Plans for meeting the costs Skills account/ fundraising

Transportation cost for educational trips shall be calculated in the following manner:

- \$16.00 per hour for driver (2 hour minimum)
- \$ 3.15 per hour to cover fixed charges (SS, retirement. etc.)
- \$19.15** total to be remitted to the central office per hour

Reimbursement for the bus and fuel shall be made at the rate of **\$.75** per mile.

*Refer to Board Policy 4.302

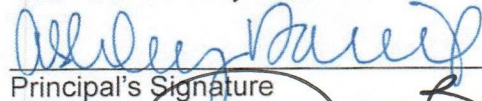
Principal's Signature

APPROVED
BY WC SUPERINTENDENT

Superintendent's Signature

4.7.26
Date

4-7-26
Date

Date Approved by the Board of Education _____

WASHINGTON COUNTY DEPARTMENT OF EDUCATION
Jonesborough, Tennessee

School Educational Trip Authorization*

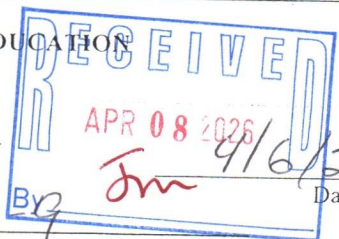

School DAVID Crockett Date of Trip 5-8-5 BY Jm Date of Request 4/6/26

Estimated Time of Departure 5-8 and Return 5-9 Total Time Away 2

Destination (include location) Hardin Valley

Teacher Kassandra Wynn Class _____ Grade 9-12

Nicole Piazza _____

Levi Sumner Jr _____

Chaperones Gillian Ridelle Number of Students Involved 40

Estimated Total Miles (Both Ways) of Trip 218

Bus Driver Mr. Bellamy Bus Number _____

Has the cafeteria manager been notified about the lunch count? Yes

Will the chaperones have a list (roll) that they are responsible for? Yes

As you plan the trip, will all children be given instructions as to what they should do if they become separated (lost) from the group?
Yes

Will you have on file parental release forms signed by parents or legal guardians? Yes

Explain the educational value of the trip:
TSSAA STATE Sectional Track

Transportation cost for educational trips shall be calculated in the following manner:
\$16.00 per hour for driver (2 hour minimum)
\$ 3.15 per hour to cover fixed charges (SS, Retirement, etc.)
\$19.15 Total to be remitted to the central office per hour

Reimbursement for the bus and fuel shall be made at the rate of \$.75 per mile.

Chali
Principal's Signature Date 4/8/26

*Refer to Board Policy 4.302

APPROVED
BY WC SUPERINTENDENT
[Signature]
Superintendent's Signature Date 4/8/26

WASHINGTON COUNTY DEPARTMENT OF EDUCATION
Jonesborough, Tennessee

School Educational Trip Authorization*

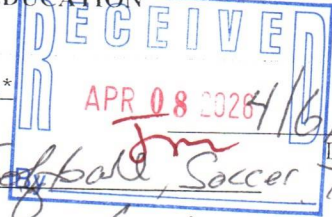

School DAVID CROCKETT Date of Trip Baseball, Softball, Soccer Track Date of Request 4/16/26

Estimated Time of Departure 5/18 and Return 5/23 Total Time Away 6 days

Destination (include location) Murfreesboro TN

Teacher Alex Dulancy Class Baseball, Softball Grade 9-12

Kassandra Wynn Soccer Track

Carlos Campos, Brian Miller

Chaperones _____ Number of Students Involved 80

_____ Estimated Total Miles (Both Ways) of Trip 544

Bus Driver Mr. Bellamy Bus Number _____

Alex Dulancy

Has the cafeteria manager been notified about the lunch count? Yes

Will the chaperones have a list (roll) that they are responsible for? Yes

As you plan the trip, will all children be given instructions as to what they should do if they become separated (lost) from the group?
Yes

Will you have on file parental release forms signed by parents or legal guardians? Yes

Explain the educational value of the trip:

TSSAA STATE TOURNAMENT DATES

Transportation cost for educational trips shall be calculated in the following manner:

- \$16.00 per hour for driver (2 hour minimum)
- \$ 3.15 per hour to cover fixed charges (SS, Retirement, etc.)
- \$19.15 Total to be remitted to the central office per hour

Reimbursement for the bus and fuel shall be made at the rate of \$.75 per mile.

Charlie Con
Principal's Signature _____ Date 4/8/26

*Refer to Board Policy 4.302

APPROVED BY WC SUPERINTENDENT
[Signature]
Superintendent's Signature _____ Date 4/8/26

Washington County Department of Education
School Educational **OVERNIGHT** Trip Authorization*

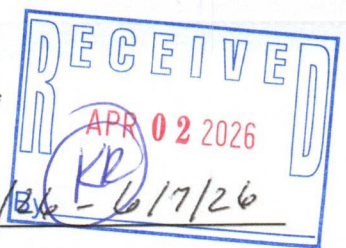

Date of Request 4/2/26 School David Crockett Trip Date 6/5/26 - 6/17/26

Estimated time of departure 5pm the 5th and return 5pm the 7th total time away 3 DAYS

Destination (include location) High Point University - (TEAM CAMP)

Teacher Sam Tarlton Class Basketball TEAM Grade 9th - 12th

Chaperones Sam Tarlton

Number of Students Involved 25

Luke Hopson

Estimated Total Miles (both ways) of Trip 300 miles

Travis Gouge

Bus Driver/Number _____ Bus Driver/ Number _____

Will Chaperones have a list (roll) that they are responsible for? Yes

As you plan the trip, will all children be given instructions as to what they should do if they become separated (lost) from the group? Yes

Will you have on file parental release forms signed by parents or legal guardians? Yes

Explain the educational value of the trip: TEAM CAMP for BASKETBALL

Total Cost Estimate \$3,000

Plans for meeting the costs BASKETBALL ACCOUNT

Transportation cost for educational trips shall be calculated in the following manner:

- \$16.00 per hour for driver (2 hour minimum)
- \$ 3.15 per hour to cover fixed charges (SS, retirement. etc.)
- \$19.15 total to be remitted to the central office per hour

Reimbursement for the bus and fuel shall be made at the rate of \$.75 per mile.

*Refer to Board Policy 4.302

Ashelee Davis
Principal's Signature

4.2.26
Date

APPROVED
BY WC SUPERINTENDENT
[Signature]
Superintendent's Signature

4/2/2026
Date

Date Approved by the Board of Education _____

Washington County Department of Education
School Educational **OVERNIGHT** Trip Authorization*

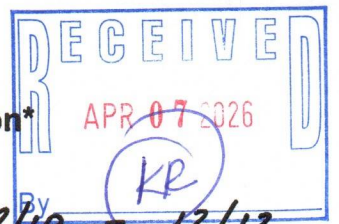

Date of Request 4-1-26 School Daniel Boone Trip Date 12/10 - 12/12

Estimated time of departure 3:00 PM and return 5:00 PM total time away 2 days

Destination (include location) KNIGHTSTOWN, INDIANA HOOSIER GYM

Teacher COACH JOHN GOOD Class BASKETBALL Grade _____

COACH CODY CONNELL BASKETBALL

Chaperones ASST. COACHES - MATT LORENZEN Number of Students Involved 28

JEANIE GOOD, JASON LONG, JONAH Estimated Total Miles (both ways) of Trip 798

NICKLES, TRAVIS LEDFORD, MATT ROBBINS

Bus Driver/Number CHARTER BUS OR VANS Bus Driver/ Number _____

Will Chaperones have a list (roll) that they are responsible for? YES

As you plan the trip, will all children be given instructions as to what they should do if they become separated (lost) from the group? YES

Will you have on file parental release forms signed by parents or legal guardians? YES

Explain the educational value of the trip: Opportunity to play in the Historical Hoosier Gym where the movie HOOSIERS was filmed in 1986

Total Cost Estimate \$5000.00

Plans for meeting the costs DONATIONS ; Annual PUTT-PUTT FUNDRAISER

Transportation cost for educational trips shall be calculated in the following manner:
\$16.00 per hour for driver (2 hour minimum)
\$ 3.15 per hour to cover fixed charges (SS, retirement, etc.)
\$19.15 total to be remitted to the central office per hour

Leaving Thurs after school - missing 1 day.

Reimbursement for the bus and fuel shall be made at the rate of \$.75 per mile.

*Refer to Board Policy 4.302

Stephanie Gray
Principal's Signature

4/7/26
Date

APPROVED BY WC SUPERINTENDENT
[Signature]
Superintendent's Signature

4/6/2026
Date

Date Approved by the Board of Education _____

Washington County Department of Education
School Educational **OVERNIGHT** Trip Authorization*

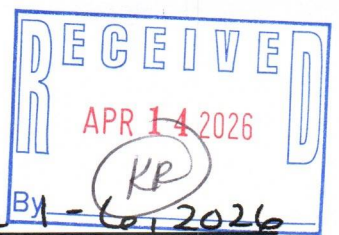

Date of Request 3/7/26 School Daniel Boone HS Trip Date June 1-6, 2026

Estimated time of departure 8:00am and return 12:00 pm total time away 5.5 days

Destination (include location) Atlanta Georgia, National Convention SkillsUSA

Teacher Lisa Cox Class SkillsUSA Grade 12

Chaperones _____

Number of Students Involved 1

Estimated Total Miles (both ways) of Trip 600 mile

Bus Driver/Number School Van (CTE) Bus Driver/ Number _____

Will Chaperones have a list (roll) that they are responsible for? yes

As you plan the trip, will all children be given instructions as to what they should do if they become separated (lost) from the group? yes

Will you have on file parental release forms signed by parents or legal guardians? yes

Explain the educational value of the trip: Lilly Fleenor will be competing at the National level in Early Childhood Education. She will interview and then plan, write, and implement a lesson and activity for Pre K-

Total Cost Estimate \$3500

Plans for meeting the costs CTSO funds and calendar fundraiser.

Transportation cost for educational trips shall be calculated in the following manner:
\$16.00 per hour for driver (2 hour minimum)
\$ 3.15 per hour to cover fixed charges (SS, retirement, etc.)
\$19.15 total to be remitted to the central office per hour

Reimbursement for the bus and fuel shall be made at the rate of \$.75 per mile.
*Refer to Board Policy 4.302

Stephanie Gray
Principal's Signature

4/14/26
Date

APPROVED
BY WC SUPERINTENDENT
[Signature]
Superintendent's Signature

4/14/2026
Date

Date Approved by the Board of Education _____

Washington County Department of Education
School Educational **OVERNIGHT** Trip Authorization*

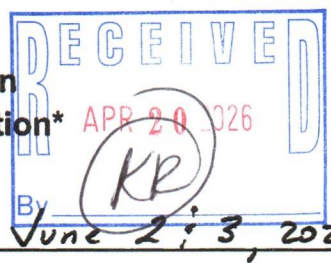

Date of Request 4-17-26 School Daniel Boone Trip Date June 2 & 3, 2026

Estimated time of departure 8:00 AM and return 5:00 pm total time away 2 days

Destination (include location) Knoxville, TN KNOX WEBB High School

Teacher COACH JOHN GOOD Class Girls Basketball Grade 9-12

Chaperones COACHES: Matt Lorenzen

Number of Students Involved 20

JENNIE GOOD

Estimated Total Miles (both ways) of Trip 220

JASON LONG

Bus Driver/Number X-99

Bus Driver/ Number COACH JOHN GOOD

Will Chaperones have a list (roll) that they are responsible for? Yes

As you plan the trip, will all children be given instructions as to what they should do if they become separated (lost) from the group? Yes

Will you have on file parental release forms signed by parents or legal guardians? Yes

Explain the educational value of the trip: Team Camp

Total Cost Estimate \$1000.00

Plans for meeting the costs Fundraisers

Transportation cost for educational trips shall be calculated in the following manner:

- \$16.00 per hour for driver (2 hour minimum)
- \$ 3.15 per hour to cover fixed charges (SS, retirement, etc.)
- \$19.15 total to be remitted to the central office per hour

Reimbursement for the bus and fuel shall be made at the rate of \$.75 per mile.

*Refer to Board Policy 4.302

[Signature]
Principal's Signature

4/17/26
Date

APPROVED
BY WC SUPERINTENDENT
[Signature]
Superintendent's Signature

4/20/26
Date

Date Approved by the Board of Education _____

Washington County Department of Education
School Educational **OVERNIGHT** Trip Authorization*

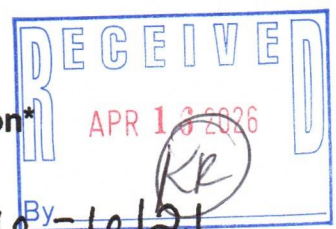

Date of Request 4/15/2026 School DBHS Trip Date 4/16 - 6/21

Estimated time of departure _____ and return _____ total time away 6 days

Destination (include location) Indianapolis, IN Convention Center

Teacher Jessica Walker Class HOSA Competition - Grade 10-12
Michelle Phillips teams

Chaperones Jessica Walker Number of Students Involved 10

Michelle Phillips Estimated Total Miles (both ways) of Trip 906

Brandon Walker

Bus Driver/Number School vans (CTE) Bus Driver/Number School vans (CTE)

Will Chaperones have a list (roll) that they are responsible for? yes

As you plan the trip, will all children be given instructions as to what they should do if they become separated (lost) from the group? yes

Will you have on file parental release forms signed by parents or legal guardians? yes

Explain the educational value of the trip: HOSA International Leadership Conference is an opportunity for students to further develop skills, compete at a higher level, and connect with future healthcare professionals across the country.

Total Cost Estimate \$10,000 approximate

Plans for meeting the costs HOSA fundraiser - CTE Funds - individual monies

Transportation cost for educational trips shall be calculated in the following manner:
\$16.00 per hour for driver (2 hour minimum)
\$ 3.15 per hour to cover fixed charges (SS, retirement, etc.)
\$19.15 total to be remitted to the central office per hour

Reimbursement for the bus and fuel shall be made at the rate of \$.75 per mile.
*Refer to Board Policy 4.302

Stephanie J. [Signature]
Principal's Signature
APPROVED
BY WC SUPERINTENDENT
[Signature]
Superintendent's Signature

4/16/26
Date
4/16/2026
Date

Date Approved by the Board of Education _____

Washington County Department of Education
School Educational **OVERNIGHT** Trip Authorization*

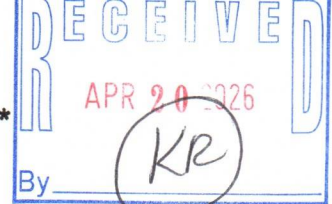

Date of Request 4-17-24 School Daniel Boone Trip Date June 11-15, 2024

Estimated time of departure 8:00 am and return 5:00 pm total time away 3 day

Destination (include location) Nashville, TN

Teacher COACH JOHN GOOD Class Girls Basketball Grade 9-12

Chaperones Coaches: Matt Lorenson
Jennie Good
Jason Long

Number of Students Involved 10

Estimated Total Miles (both ways) of Trip 560

Bus Driver/Number X-99

Bus Driver/ Number COACH JOHN GOOD

Will Chaperones have a list (roll) that they are responsible for? Yes

As you plan the trip, will all children be given instructions as to what they should do if they become separated (lost) from the group? Yes

Will you have on file parental release forms signed by parents or legal guardians? Yes

Explain the educational value of the trip: Team Camp

Total Cost Estimate \$2500.00

Plans for meeting the costs Fundraisers

Transportation cost for educational trips shall be calculated in the following manner:

\$16.00 per hour for driver (2 hour minimum)

\$ 3.15 per hour to cover fixed charges (SS, retirement, etc.)

\$**19.15** total to be remitted to the central office per hour

Reimbursement for the bus and fuel shall be made at the rate of **\$.75** per mile.

*Refer to Board Policy 4.802

Stephanie
Principal's Signature

4/17/24

Date

APPROVED
BY WC SUPERINTENDENT
[Signature]
Superintendent's Signature

4/20/24

Date

Date Approved by the Board of Education _____

Washington County Department of Education
School Educational **OVERNIGHT** Trip Authorization*



Date of Request April 24, 2026 School Daniel Boone Trip Date July 13-15, 2026
Estimated time of departure July 13 and return July 15 total time away 3 days
Destination (include location) Yearbookpalooza in Orlando, Florida
Teacher Karin Orchard Class Yearbook Grade 10-12

Chaperones Jamie Love Number of Students Involved 12
Jeremy Hughes Estimated Total Miles (both ways) of Trip 1302

Bus Driver/Number Flying Bus Driver/ Number —

Will Chaperones have a list (roll) that they are responsible for? yes

As you plan the trip, will all children be given instructions as to what they should do if they become separated (lost) from the group? yes

Will you have on file parental release forms signed by parents or legal guardians? yes

Explain the educational value of the trip: Yearbookpalooza is put on by Varsity - our yearbook company. We will receive training and creative advice on creating our yearbook. See attached sheet for details!

Total Cost Estimate \$8,767.00

Plans for meeting the costs We have enough money in our account to cover all expenses.

Transportation cost for educational trips shall be calculated in the following manner:
\$16.00 per hour for driver (2 hour minimum)
\$ 3.15 per hour to cover fixed charges (SS, retirement. etc.)
\$19.15 total to be remitted to the central office per hour

Reimbursement for the bus and fuel shall be made at the rate of \$.75 per mile.

*Refer to Board Policy 4.392

Stephanie
Principal's Signature
APPROVED
BY WC SUPERINTENDENT
[Signature]
Superintendent's Signature

4/24/26
Date
4/27/26
Date

Date Approved by the Board of Education _____



ORLANDO
2026

YEARBOOKPALOOZA // JULY 13-15, 2026 THE FLORIDA HOTEL & CONFERENCE CENTER, ORLANDO, FL

Florida's premier summer yearbook workshop, Yearbookpalooza is a three-day experience packed with hands-on learning, creative inspiration, and team-building fun for advisers and staff. Hosted by your local Varsity Yearbook Reps, Palooza brings together schools from across the country to dive into sessions led by industry experts. Get all the details at Yearbookpalooza.com

WHO CAN ATTEND?

- Yearbook Advisers (New & Returning)
- Editors & Yearbook Staffers
- Chaperones

PALOOZA HIGHLIGHTS

- Breakout sessions on design, journalism, photography, and marketing
- Inner Circle & Photo Track (pre-registration required) for those who want a next level experience
- New Adviser Bootcamp
- Spirit Days & After Hours social events (bingo, talent show, silent disco)
- Contests, games, and team-building activities

WHAT'S INCLUDED

- Registration fee includes breakfast Tuesday and Wednesday mornings for all participants plus an appreciation lunch for advisers on Tuesday
- Palooza T-Shirt
- Access to all classes plus opportunities to register for one-on-one consultation with "Brainstorm with a Pro" and opportunities to meet with a professional cover artist directly from the plant in KC!

REGISTRATION DETAILS

- Official registration opens March 1, 2026
- Student / Adviser Early Bird Registration \$245 (then increases to \$270)
- Limited seats for some specialty tracks — reserve early!

HOTEL DETAILS

- Hotel located inside The Florida Mall for easy dining options
- Special room rates available for participants

WHY PALOOZA?

- Yearbookpalooza gives advisers and staffs the tools and confidence to design, produce, market, and manage an incredible yearbook.
- Hands-on sessions and collaborative activities help teams start planning their book right away while connecting with other schools to share ideas, troubleshoot challenges, and get inspired.
- Fun events, spirit days, and friendly competitions build teamwork and enthusiasm, making the experience both educational and unforgettable.
- New advisers also receive dedicated support through Bootcamp sessions and have the opportunity to connect and collaborate with fellow advisers.



YBKCREATIVE@VARSITY.COM
YEARBOOKPALOOZA.COM



Washington County Department of Education
School Educational **OVERNIGHT** Trip Authorization



Date of Request 4-24-26 School Daniel Boone Trip Date Dec. 26-31 2026

Estimated time of departure 7:00 am and return 7:00 pm total time away 6 days

Destination (include location) Panama City

Teacher Cody Connell Class _____ Grade _____

Chaperones Jonah Wicler

Number of Students Involved _____

Travis Lesford

Estimated Total Miles (both ways) of Trip 1100

Matt Robbins

Bus Driver/Number _____ Bus Driver/ Number _____

Will Chaperones have a list (roll) that they are responsible for? yes

As you plan the trip, will all children be given instructions as to what they should do if they become separated (lost) from the group? yes

Will you have on file parental release forms signed by parents or legal guardians? yes

Explain the educational value of the trip: Christmas Tournament

Total Cost Estimate 12,000

Plans for meeting the costs Fundraising

Transportation cost for educational trips shall be calculated in the following manner:

\$16.00 per hour for driver (2 hour minimum)

\$ 3.15 per hour to cover fixed charges (SS, retirement, etc.)

\$19.15 total to be remitted to the central office per hour

Reimbursement for the bus and fuel shall be made at the rate of **\$.75** per mile.

*Refer to Board Policy 4.302

Principal's Signature _____

Date 4/27/26

APPROVED BY WC SUPERINTENDENT
Superintendent's Signature _____

Date 4/27/26

Date Approved by the Board of Education _____

Washington County Department of Education
School Educational **OVERNIGHT** Trip Authorization*

RECEIVED
APR 27 2026
KR
Albers

Date of Request 4-24-26 School Daniel Boone Trip Date June 5-7 2026

Estimated time of departure 7:00 am and return 7:00 pm total time away 3 days

Destination (include location) MTSU

Teacher Cody Connett Class _____ Grade _____

Chaperones Jonah Nickles

Number of Students Involved 14

Travis Ledford

Estimated Total Miles (both ways) of Trip 440

Matt Robbins

Bus Driver/Number _____ Bus Driver/ Number _____

Will Chaperones have a list (roll) that they are responsible for? yes

As you plan the trip, will all children be given instructions as to what they should do if they become separated (lost) from the group? yes

Will you have on file parental release forms signed by parents or legal guardians? yes

Explain the educational value of the trip: Team Camp

Total Cost Estimate \$3,000

Plans for meeting the costs Fundraising

Transportation cost for educational trips shall be calculated in the following manner:

\$16.00 per hour for driver (2 hour minimum)

\$ 3.15 per hour to cover fixed charges (SS, retirement, etc.)

\$19.15 total to be remitted to the central office per hour

Reimbursement for the bus and fuel shall be made at the rate of \$.75 per mile.

*Refer to Board Policy 4.302

Principal's Signature

Date

APPROVED
BY WC SUPERINTENDENT

Superintendent's Signature

Date

Date Approved by the Board of Education _____

Mr. Jerry S. Boyd
Superintendent



405 W. College St
Jonesborough, TN 37659
423-753-1100

DATE: April 28, 2026

TO: Washington County Board of Education

FROM: WCS Special Projects Committee

RE: DCHS Gymnasium Naming

The WCS Special Projects Committee met on April 1, 2026 to discuss the request to name the DCHS gymnasium after Hobart Powell, a former teacher, administrator and coach for WCS. The WCS Special Projects Committee formally recommends fulfilling this request.

Thank you,

Dr. Jarrod Adams
Chief Operations Officer
Washington County Schools

Washington County Board of Education

Eric Barnes
Annette Buchanan, Chair
Keith Ervin

Chad Fleenor
David Hammond, Vice Chair
Gregg Huddleston

Mike Masters
Whitney Riddle
Vince Walters

Education Capital Projects Fund (\$1,000s)

FY2027 - FY2031

Pending Final WCBOE Approval on 05/07/2026

Projected Penny Value at .75% Growth

Property Tax Pennies

Pennies Reallocated to Debt Service

Capital Project Pennies

Source of Funds for Capital Expenditures

Property Tax Projected at 0.75% Growth

Other Revenue (Grants, PY Tax, Other Tax, Investment Income)

Unused Funds from the Prior Year

Revenues

Capital Projects Encumbrance Projection

	2025	2026	2027	2028	2029	2030	2031	
Projected Penny Value at .75% Growth	546,950	555,625	559,793	563,992	568,222	572,484	576,778	
Property Tax Pennies	17	5.0	5.0	5.0	5.0	5.0	5.0	
Pennies Reallocated to Debt Service	0	0	0	0	0	0	0	
Capital Project Pennies	5.34	5.00	5.0	5.0	5.0	5.0	5.0	
Source of Funds for Capital Expenditures								
Property Tax Projected at 0.75% Growth	2,945	2,778	2,799	2,820	2,841	2,862	2,884	
Other Revenue (Grants, PY Tax, Other Tax, Investment Income)		163	472	163	163	163	163	
Unused Funds from the Prior Year	6,674	6,702	2,804	2,940	2,503	3,527	302	
Revenues	7,096	9,643	6,075	5,923	5,507	6,552	3,349	
Capital Projects Encumbrance Projection								
1 Trustee Commission	145	96	65	60	60	61	61	1
2 Technology (Smart Classroom, Tablets, Audio)	550	500						2
3 Technology (Campus Safety and Security)-Fire Alarms (Res. # 25-07-12)	200	250						3
4 School Buses/Student Transportation	600	1,120	1,720	1,740	1,040	1,740	1,220	4
5 School Security -- High Schools Entry Enhancements/Updates	1,307	193						5
6 School Security -- K-8 Schools Entry Enhancements/Updates		2,000						6
7 School Playground Upgrades	150	0						7
8 New BCES-Add. Boiler, pump, pipping, etc. (removed for reconsideration)			310					8
9 Campus/Property Improvements (Asphalt, Concrete, etc.)			540					9
10 DBHS HVAC Water Cooling/Heating System Replacement (Resolution # 25-03-06)		2,270						10
11 DBHS HVAC Project_Natural Gas Infrastructure (Resolution #25-07-11)		310						11
12 DCHS Reroof (Main Building)						3,550		12
13 DCHS Reroof (New Annex Building)		0	500					13
14 DCHS Reroof (Old Annex Building)					300			14
15 Asbury Roof Replacement (back section)				300				15
16 Sulphur Springs HVAC Update/Replacement				1,200				16
17 Lamar Roof Replacement							1,600	17
18 Ridgeview Roof Replacement (Cafeteria Section)				120				18
19 Gray Elementary School HVAC						900		19
20 Fall Branch Roof Replacement					580			20
21 Transportation Building Roof Repair		100	0					21
45 Transfer								45
Total Expenditure Projection	2,916	6,839	3,135	3,420	1,980	6,251	2,881	46
Projected Fund Balance (Deficit)	6,702	2,804	2,940	2,503	3,527	302	468	47

725 West Walnut Street
 Johnson City, TN 37604
 PH: 423-282-5400
www.inspirebusinessinteriors.com

Date Printed: 4/24/2026
 Valid 30 Days From Print
 Sales Name: Tracy Johnson
 Design Name: Isabelle Tisor

SOLD TO:

Washington County Schools
 405 W. College St.
 Jonesborough, TN 37659

SHIP TO:

Washington County Schools
 405 W. College St.
 Jonesborough, TN 37659

Sales Number:

PROPOSAL

Washington Co. Schools
 Captial Project 2026, K-8 Classroom Budget
 OMNIA #R240117

LINE	IMAGE	QTY	PRODUCT	UNIT SELL	EXT SELL
1		13	HLDV-MRECT2026A Rectangle Student desk with adj leg 20"x26" 2Pack Select Glide, Select Hard Plastic Color, Select Paint Option, Select Grade 1 Paint	\$330.00	\$4,290.00
			Nylon Hard Surface Harvest P1 Paint Opts Charcoal		

LINE	IMAGE	QTY	PRODUCT	UNIT SELL	EXT SELL
2		7	HSS4L-18B SmartLink Seating 18" 4L Chair 4/carton Select Glide, Select Shell Color, Select Paint Option, Select Grade 1 Paint	\$326.00	\$2,282.00
			Nylon Onyx P1 Paint Opts Textured Charcoal		

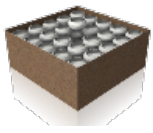
LINE	IMAGE	QTY	PRODUCT	UNIT SELL	EXT SELL
3		3	HGDK3-F Snap-On Felt Glide Cap Kit	\$71.20	\$213.60
			Finish Options	NA	

LINE	IMAGE	QTY	PRODUCT	UNIT SELL	EXT SELL
4		0	SUBTOTAL	\$0.00	\$6,785.60
			(1) K-8 Classroom to Seat 25		

LINE	IMAGE	QTY	PRODUCT	UNIT SELL	EXT SELL
5		1		\$218.89	\$218.89
			HNI Tariff Surcharge		

LINE	IMAGE	QTY	PRODUCT	UNIT SELL	EXT SELL
6		1		\$1,000.00	\$1,000.00
			Delivery & Installation		

GRAND TOTAL				\$8,004.49	
--------------------	--	--	--	------------	--

Notes:

Signature: _____ Date: _____ PO #: _____

Approved By: _____ Title: _____

TERMS & CONDITIONS

Notes:

Pricing does not include sales tax. Freight, if any, will be added at the time of invoice. A signature is needed to proceed with order. Payment terms: 50% deposit upon order. Net 20 upon final invoice.

Terms:

Client agrees that the list of items herein has been reviewed and accurately sets forth the items to be purchased. The client acknowledges and agrees that the items to be purchased are made to order and may not be returned and that the purchase of the items is final. The client agrees to pay the purchase price according to net 20 days payment terms.

Any unpaid balance shall accrue interest of 1 1/2% per month. Buyer agrees to pay the balance, as extended, together with all cost of collection, including reasonable attorney's fees and court costs if collection by law or by an attorney at law is necessary.

725 West Walnut Street
 Johnson City, TN 37604
 PH: 423-282-5400
www.inspirebusinessinteriors.com

Date Printed: 4/24/2026
 Valid 30 Days From Print
 Sales Name: Tracy Johnson
 Design Name: Isabelle Tisor

SOLD TO:

Washington County Schools
 405 W. College St.
 Jonesborough, TN 37659

SHIP TO:

Washington County Schools
 405 W. College St.
 Jonesborough, TN 37659

Sales Number:

PROPOSAL

Washington Co. Schools
 Captial Project 2026, High School Classrooms
 OMNIA #R240117

LINE	IMAGE	QTY	PRODUCT	UNIT SELL	EXT SELL
1		240	HLDV-MRECT2026A Rectangle Student desk with adj leg 20"x26" 2Pack Select Glide, Select Hard Plastic Color, Select Paint Option, Select Grade 1 Paint	\$330.00	\$79,200.00
			Nylon Hard Surface Harvest P1 Paint Opts Charcoal		

LINE	IMAGE	QTY	PRODUCT	UNIT SELL	EXT SELL
2		120	HSS4L-18B SmartLink Seating 18" 4L Chair 4/carton Select Glide, Select Shell Color, Select Paint Option, Select Grade 1 Paint	\$326.00	\$39,120.00
			Nylon Onyx P1 Paint Opts Textured Charcoal		

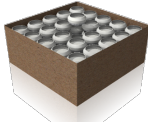
LINE	IMAGE	QTY	PRODUCT	UNIT SELL	EXT SELL
3		39	HGDK3-F Snap-On Felt Glide Cap Kit	\$71.20	\$2,776.80
			Finish Options		NA

LINE	IMAGE	QTY	PRODUCT	UNIT SELL	EXT SELL
4		0	SUBTOTAL DCHS-15 Classrooms @ 32 Students	\$0.00	\$121,096.80

LINE	IMAGE	QTY	PRODUCT	UNIT SELL	EXT SELL
5		240	HLDV-MRECT2026A Rectangle Student desk with adj leg 20"x26" 2Pack	\$330.00	\$79,200.00
			Select Glide, Select Hard Plastic Color, Select Paint Option, Select Grade 1 Paint		Nylon Hard Surface White P1 Paint Opts Titanium

LINE	IMAGE	QTY	PRODUCT	UNIT SELL	EXT SELL
6		120	HSS4L-18B SmartLink Seating 18" 4L Chair 4/carton	\$326.00	\$39,120.00
			Select Glide, Select Shell Color, Select Paint Option, Select Grade 1 Paint		Nylon Bullseye Red P1 Paint Opts Charblack

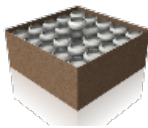
LINE	IMAGE	QTY	PRODUCT	UNIT SELL	EXT SELL
7		39	HGDK3-F Snap-On Felt Glide Cap Kit	\$71.20	\$2,776.80
			Finish Options		NA

LINE	IMAGE	QTY	PRODUCT	UNIT SELL	EXT SELL
8		0	SUBTOTAL	\$0.00	\$121,096.80
			DBHS-15 Classrooms @ 32 Students		

LINE	IMAGE	QTY	PRODUCT	UNIT SELL	EXT SELL
9		1		\$7,812.69	\$7,812.69
			HNI Tariff Surcharge		

LINE	IMAGE	QTY	PRODUCT	UNIT SELL	EXT SELL
10		1		\$35,714.29	\$35,714.29
			Delivery & Installation		

GRAND TOTAL				\$285,720.58	
--------------------	--	--	--	--------------	--

Notes:

Signature: _____ Date: _____ PO #: _____

Approved By: _____ Title: _____

TERMS & CONDITIONS

Notes:

Pricing does not include sales tax. Freight, if any, will be added at the time of invoice. A signature is needed to proceed with order. Payment terms: 50% deposit upon order. Net 20 upon final invoice.

Terms:

Client agrees that the list of items herein has been reviewed and accurately sets forth the items to be purchased. The client acknowledges and agrees that the items to be purchased are made to order and may not be returned and that the purchase of the items is final. The client agrees to pay the purchase price according to net 20 days payment terms.

Any unpaid balance shall accrue interest of 1 1/2% per month. Buyer agrees to pay the balance, as extended, together with all cost of collection, including reasonable attorney's fees and court costs if collection by law or by an attorney at law is necessary.

Agreement ID: P25-0326

FDP Data Transfer and Use Agreement (“Agreement”)

Provider: Washington County Schools	Recipient: East Tennessee State University
-------------------------------------	--

Provider Scientist Name: Twana McKinney Email: mckinneyt@wcde.org	Recipient Scientist Name: Ronnie Gross Email: grossrd@etsu.edu
---	--

Project Title: ETSU GEAR UP

Agreement Term
 Start Date: October 1, 2025
 End Date: (choose one)
 1) ___ years after the Start Date;
 2) Completion of the Project; or
 3) ___ years after the Start Date or upon completion of the project, whichever occurs first.

Attachment 2 Type: Personally Identifiable Information - FERPA

Terms and Conditions

1) Reimbursement of Costs: If applicable, Recipient shall reimburse Provider for any costs associated with the preparation, compilation, and transfer of the Data to the Recipient. Costs shall not include payments for research effort by the Provider.

None

This Agreement is in support of agreement # _____, which shall cover reimbursement of costs. In the event of any conflict of terms, this Agreement shall control regarding issues of data transfer and use.

As set forth herein:

2) Provider shall provide the data set described in Attachment 1 (the “Data”) to Recipient for the research purpose set forth in Attachment 1 (the “Project”). Provider shall retain ownership of any rights it may have in the Data, and Recipient does not obtain any rights in the Data other than as set forth herein.

3) Recipient shall not use the Data except as authorized under this Agreement. The Data will be used solely to conduct the Project and solely by Recipient Scientist and Recipient’s faculty, employees, fellows, students, and agents (“Recipient Personnel”) and Collaborator Personnel (as defined in Attachment 3) that have a need to use, or provide a service in respect of, the Data in connection with the Project and whose obligations of use are consistent with the terms of this Agreement (collectively, “Authorized Persons”).

4) Except as authorized under this Agreement or otherwise required by law, Recipient agrees to retain control over the Data and shall not disclose, release, sell, rent, lease, loan, or otherwise grant access to the Data to any third party, except Authorized Persons, without the prior written consent of Provider. Recipient agrees to establish appropriate administrative, technical, and physical safeguards to prevent unauthorized use of or access to the Data and comply with any other special requirements relating to safeguarding of the Data as may be set forth in Attachment 2.

Agreement ID: P25-0326

- 5) Recipient agrees to use the Data in compliance with all applicable laws, rules, and regulations, as well as all professional standards applicable to such research.
- 6) Recipient is encouraged to make publicly available the results of the Project. Before Recipient submits a paper or abstract for publication or otherwise intends to publicly disclose information about the results of the Project, the Provider will have thirty (30) days from receipt to review proposed manuscripts and ten (10) days from receipt to review proposed abstracts to ensure that the Data is appropriately protected. Provider may request in writing that the proposed publication or other disclosure be delayed for up to thirty (30) additional days as necessary to protect proprietary information.
- 7) Recipient agrees to recognize the contribution of the Provider as the source of the Data in all written, visual, or oral public disclosures concerning Recipient's research using the Data, as appropriate in accordance with scholarly standards and any specific format that has been indicated in Attachment 1.
- 8) Unless terminated earlier in accordance with this section or extended via a modification in accordance with Section 13, this Agreement shall expire as of the End Date set forth above. Either party may terminate this Agreement with thirty (30) days written notice to the other party's Authorized Official as set forth below. Upon expiration or early termination of this Agreement, Recipient shall follow the disposition instructions provided in Attachment 1, provided, however, that Recipient may retain one (1) copy of the Data to the extent necessary to comply with the records retention requirements:
 - I. under any law, regulation, or Recipient institutional policy, and
 - II. for instances where Data disposal is infeasible, and
 - III. for the purposes of research integrity and verification.

The restrictions set forth in this Agreement (as applicable) shall survive and apply to such archival copy so long as Recipient holds the Data.

- 9) Except as provided below or prohibited by law, any Data delivered pursuant to this Agreement is understood to be provided "AS IS." PROVIDER MAKES NO REPRESENTATIONS AND EXTENDS NO WARRANTIES OF ANY KIND, EITHER EXPRESSED OR IMPLIED. THERE ARE NO EXPRESS OR IMPLIED WARRANTIES OF MERCHANTABILITY OR FITNESS FOR A PARTICULAR PURPOSE, OR THAT THE USE OF THE DATA WILL NOT INFRINGE ANY PATENT, COPYRIGHT, TRADEMARK, OR OTHER PROPRIETARY RIGHTS. Notwithstanding, Provider, to the best of its knowledge and belief, has the right and authority to provide the Data to Recipient for use in the Project.
- 10) Except to the extent prohibited by law, the Recipient assumes all liability for damages which may arise from its use, storage, disclosure, or disposal of the Data. The Provider will not be liable to the Recipient for any loss, claim, or demand made by the Recipient, or made against the Recipient by any other party, due to or arising from the use of the Data by the Recipient, except to the extent permitted by law when caused by the gross negligence or willful misconduct of the Provider. No indemnification for any loss, claim, damage, or liability is intended or provided by either party under this Agreement.
- 11) Neither party shall use the other party's name, trademarks, or other logos in any publicity, advertising, or news release without the prior written approval of an authorized representative of that party. The parties agree that each party may disclose factual information regarding the existence and purpose of the relationship that is the subject of this Agreement for other purposes without written permission from the other party provided that any such statement shall accurately and appropriately describe the relationship of the parties and shall not in any manner imply endorsement by the other party whose name is being used.

12) Unless otherwise specified, this Agreement and the below listed Attachments embody the entire understanding between Provider and Recipient regarding the transfer of the Data to Recipient for the Project:

- I. Attachment 1: Project Specific Information
- II. Attachment 2: Data-specific Terms and Conditions
- III. Attachment 3: Identification of Permitted Collaborators (if any)

13) No modification or waiver of this Agreement shall be valid unless in writing and executed by duly-authorized representatives of both parties.

14) The undersigned Authorized Officials of Provider and Recipient expressly represent and affirm that the contents of any statements made herein are truthful and accurate and that they are duly authorized to sign this Agreement on behalf of their institution.

By an Authorized Official of Provider:

By an Authorized Official of Recipient:

Date

Date

Name: Cindy Hayes
Title: Chief Academic Officer

Name: Nicholas E. Hagemeyer
Title: Vice Provost for Research

Contact Information for Formal Notices:

Contact Information for Formal Notices:

Name: Twana McKinney
Address: 405 West College Street
Jonesborough, TN 37659

Name: Rachel A. Bishop
Address: PO Box 70565
Johnson City, TN 37614

Email: mckinneyt@wcde.org
Phone: 423-753-1100

Email: bishopra1@etsu.edu
Phone: 423-439-6045

Attachment 1
Data Transfer and Use Agreement
Project Specific Information

1. Description of Data:

Data will be shared in relation to the ETSU GEAR UP grant. Recipient is the prime awardee, and the grant has been awarded by the U.S. Department of Education.

The data points included in Exhibit A to this Data Transfer and Use Agreement will be transferred to Recipient and to third-party entity Vela Institute. Provider will provide data relating to students attending its schools. Provider will create export reports and will provide the data following this collection schedule: September, January, and June for each year of the grant program.

Provider will also share sign-in sheets for all GEAR UP activities as well as a yearly list of high school graduates from GEAR UP schools, including First Name, Last Name, and Date of Birth.

Provider will also collaborate with Recipient to administer surveys to students relating to pre-treatment college knowledge and pre-treatment FAFSA completions and college applications. These surveys will be administered through Qualtrics and will be shared for completion at least annually.

2. Description of Project:

The GEAR UP program provides financial and academic assistance and support, mentoring, and outreach to students with an aim to increase the number of low-income and first-generation students who are prepared to enroll and succeed in college. ETSU GEAR UP will serve 5,198 students in six low income Local Education Agencies (LEAs) across East TN during the seven-year grant period. Services will be provided to two cohorts of students. ETSU GEAR UP's project design is Think, Know, Act, Go: Educational Attainment and Economic Mobility. The design is grounded in the seminal college readiness work of David Conley. Adapting Conley's framework, four themes guide implementation and services: College-Going Culture (Think), Financial Literacy (Know), Academic Advising (Act), Postsecondary and Career Preparation (Go). ETSU GEAR UP provides required and permissible activities: tutoring, academic advising and counseling, dual-enrollment, college planning and financial aid workshops, mentoring, college visits, summer programming, non-cognitive skill development, financial literacy, college transition support to 7th year cohort students, and professional development to educators.

A collaborative evaluation approach with Vela Institute and ETSU research faculty will produce high quality evaluation. To meet project objectives, ETSU GEAR UP will use data to guide services, maximizing project effectiveness in meeting the needs of target LEA students and their families. Student-level data, housed in the Vela Institute's Performance Insights (Pi) database, allows for rigorous evaluation that includes longitudinal analyses of student outcomes, identification and replication of effective instructional practices, and continuous improvement of service implementation to meet program objectives, evaluate the program, and conduct a quasi-experimental research study.

Attachment 1
Data Transfer and Use Agreement
Project Specific Information

3. Provider Support and Data Transmission:

Provider shall transmit the Data to Recipient: Electronically (description below)

Name:	Ronnie Gross
Address:	Electronic transfer of data
Email:	grossrd@etsu.edu
Phone:	423-439-4002

Upon execution of this Agreement, Provider shall send any specific instructions necessary to complete the transfer of the Data to the contact person listed above, if not already included below in this section of Attachment 1.

Provider will directly share data through Vela Institute's Performance Insights (Pi) database, which pulls data directly from the Providers's student information systems. The transfer of the data and the Pi database are secured through HECVAT Lite. ETSU GEAR UP staff and Vela Institute staff will have access to the data. Data will also be shared with Recipient through ShareFile. The data will only be shared with others in aggregate, de-identified form, summarized through descriptive statistics.

Survey data generated in collaboration with Provider will be collected through Qualtrics, then stored either in the Pi database or on ETSU's OneDrive for Business.

4. Disposition Requirements upon the termination or expiration of the Agreement:

Upon expiration or early termination of this agreement, Recipient may retain one copy of the Data, in a secure location or database, to comply with records retention requirements, for the purposes of research integrity and verification, and/or for audit purposes. Recipient shall delete Data stored elsewhere.

Agreement ID: P25-0326

Attachment 2
Data Transfer and Use Agreement
Data-specific Terms and Conditions:
Personally Identifiable Information - FERPA

Additional Terms and Conditions:

1. The Data is Personally Identifiable Information, as that is defined in the Family Education Rights and Privacy Act of 1974 at 20 U.S.C. §1232(g) and regulations at 34 C.F.R. §99.3 (collectively, "FERPA") and is further categorized as Education Records and/or Treatment Records as those terms are defined in FERPA.
 - If checked, the Data is covered under a Certificate of Confidentiality, which must be asserted against compulsory legal demands, such as court orders and subpoenas for identifying information or characteristics of a research participant. See <https://grants.nih.gov/grants/guide/notice-files/NOT-OD-17-109.html> for further information.
2. Notwithstanding any statement herein to the contrary and pursuant to 34 CFR §99.31(a)(6), Provider represents that it has full authority to share the Data with the Recipient for the Project.
3. Unless otherwise required by law or legal process, Recipient shall not use or further disclose the Data other than as permitted by this Agreement. If Recipient believes it is required by law or legal process to use or disclose the Data, it will promptly notify Provider, to the extent allowed by law, prior to such use or disclosure and will disclose the least possible amount of Data necessary to fulfill its legal obligations.
4. In the event Recipient becomes aware of any use or disclosure of the Data not provided for by this Agreement, Recipient shall take any appropriate steps to minimize the impact of such unauthorized use or disclosure as soon as practicable and shall notify Provider of such use or disclosure as soon as possible, but no later than 5 business days after discovery of the unauthorized use or disclosure. Recipient shall cooperate with Provider to investigate, correct, and/or mitigate such unauthorized use or disclosure. Recipient acknowledges that Provider may have an obligation to make further notifications under applicable state law and shall cooperate with the Provider to the extent necessary to enable Provider to meet all such obligations.
5. Recipient will not use the Data, either alone or in concert with any other information, to make any effort to contact individuals who are the subjects of the Data without appropriate Institutional Review Board (IRB) approval, specific written approval from Provider, and informed consent and authorization from the individual or a waiver, if required.
6. Recipient agrees to store Data with security controls adequate to protect Personally Identifiable Information, to ensure that only Authorized Persons have access to the Data, and to maintain appropriate control over the Data at all times.
7. Pursuant to 34 CFR §99, Recipient agrees to remove and securely destroy, as directed by the Provider in Attachment 1, the Personally Identifiable Information at the earliest time at which removal and destruction can be accomplished consistent with the Project.
8. By signing this Agreement, Recipient provides assurance that its relevant institutional policies and applicable federal, state, or local laws and regulations (if any) have been followed, including the completion of any IRB review or approval that may be required prior to Recipient's use of the Data. Upon Provider's written request to the Recipient's Contact for Formal Notices identified in the signature block, Recipient shall provide documentation of its IRB-Approved Protocol.

Agreement ID: P25-0326

Attachment 3
Data Transfer and Use Agreement
Identification of Permitted Collaborators (if any)

For all purposes of this Agreement, the definition of “Collaborator Personnel” checked below will pertain:

“Collaborator Personnel” means: None. No third-party collaborators are permitted on the Project. All Authorized Persons using the Data are Recipient Personnel.

-OR-

“Collaborator Personnel” means the third parties as set forth below and agreed upon between the Parties. To be clear, Collaborator Personnel are not Recipient Personnel.

“Collaborator Personnel” means: employees third-party non-profit institution, Vela Institute, which institution (i) has agreed to collaborate on the Project, (ii) has employees who have a need to use or provide a service with respect to the Data in connection with its collaboration on the Project, and (iii) has been made aware of the terms of this Agreement and has agreed to comply, and to cause its personnel to comply, with such terms.



DEMOGRAPHICS IMPORT

(Columns in red are required)

Excel Column Reference	Column Heading	Description	Notes
A	Last Name	Student's Last Name	
B	First Name	Student's First Name	
C	Middle Name	Student's Middle Name	Middle name initial or full middle name
D	Suffix	Student's Suffix	Ex: Jr, II, Junior, III
E	Birth Date	Student's Date of Birth	Excel Data Type: Date
F	Gender	Student's Gender	F = Female M = Male NB = Nonbinary U = Unknown O = Other (deprecated) GN = Gender Neutral (deprecated) Blank cells or cells with value of O in this column will be converted to the value Unknown (U) Cells with a value of GN will be converted to Nonbinary (NB)
G	Race	Student's Race code	I = American Indian or Alaskan Native A = Asian B = Black or African American P = Native Hawaiian or Pacific Islander



Excel Column Reference	Column Heading	Description	Notes
			W = White M = Two or More Races
H	Ethnicity	Student's Ethnicity code	N = Non-Hispanic H = Hispanic Blank cells in this column will be converted to the value N.
I	Street 1	The street number and name of Student's address	
J	Street 2	Student's Apartment Number	
K	City	City where student resides	
L	State	State	Two-character state code
M	Zip	Zip code	
N	Phone	Student's Cell Phone Number (if unknown leave blank)	
O	Email	Student's Email Address (if unknown leave blank)	
P	Grade	Student's Grade Level	
Q	Student ID	This is the student's unique student ID number (issued by the school, LEA, or state)	
R	School ID	NCES School Identification Number. This number should match the School ID configured in Pi.	This is the number assigned by the National Center for Education Statistics. See Search for Public Schools - https://nces.ed.gov/ccd/schoolsearch/



Excel Column Reference	Column Heading	Description	Notes
S	LEA ID	NCES LEA Identification Number. This number should match the LEA ID configured in Pi for the school.	This is the number assigned by the National Center for Education Statistics. See Search for Public School Districts - https://nces.ed.gov/ccd/districtsearch/
T	HS GPA ^a	Student's cumulative GPA	
U	HS Grad Date	Date on which student graduated from High School	Excel Data Type: Date
V	LEP	Is the student a Limited English Proficiency student?	Y = LEP flag on N = LEP flag off Blank cells in this column will be converted to the value N.
W	IEP	Does student have an Individualized Education Plan?	Y = IEP flag on N = IEP flag off Blank cells in this column will be converted to the value N.
X	Foster Care	Does student live in a foster care system (ward, group home, private home)?	Y = Yes N = No Blank cells in this column will be converted to the value N.
Y	Homeless	Is student currently homeless (not in foster care or with parents)?	Y = Yes N = No



Excel Column Reference	Column Heading	Description	Notes
			Blank cells in this column will be converted to the value N.
Z	Mother Name	Student's Mother's Name	
AA	Mother Phone	Student's Mother's Cell Phone	
AB	Mother Email	Student's Mother's Email	
AC	Father Name	Student's Father's Name	
AD	Father Phone	Student's Father's Cell Phone	
AE	Father Email	Student's Father's Email	
AF	Guardian Name	Student's Guardian's Name	
AG	Guardian Phone	Student's Guardian's Cell Phone	
AH	Guardian Email	Student's Guardian's Email	
AI	Earned Credits	Student's cumulative number of credits earned	
AJ	Student Type^b	Specifies whether the student is a Priority student or a Cohort student.	C = Cohort P = Priority

^a A value is required if your program is a CCREC member program, and the student is in grade 9th, 10th, 11th, or 12th. Or, if your evaluation plan requires it. Please ensure with your evaluator the need for this field.

^b A valid value is required if your program is a CCREC member program, and if it is a hybrid or mixed program serving students on both cohort and priority basis.



ACADEMIC IMPORT

The academic Import file should include only those grades, i.e., marks, which are coded as final. In other words, only grades that contributed to the student's earned credits/hours figure but also including failing grades that although final, failed to yield a credit/hour figure for the student.

(Columns in red are required)

Excel Column Reference	Column Heading	Description	Notes
A	Student ID	This is the student's unique student ID number (issued by the school, LEA, or state)	
B	Last Name		
C	First Name		
D	Birth Date		Excel Data Type: Date
E	School ID	NCES School Identification Number or other unique Federal ID. This number should match the School ID configured in Pi.	This is the number assigned by the National Center for Education Statistics. See Search for Public Schools - https://nces.ed.gov/ccd/schoolsearch/
F	Grade Level	Student's grade level	Examples: 7 = 7 th grade 8 = 8 th grade
G	Course Code		Alphanumeric code for course Maximum 25 characters
H	Course Title		
I	Grading Period	This a code that denotes the schools code for final grade. Some schools record final grades once each semester and usually code them as S1 or S2. A fewer number of schools record a single final grade at the end of the school year. Yet other schools operate on a trimester basis and record final grades 3 times a year, perhaps as T1, T2, and T3	Valid values Q1-Q4 = Quarter-based grades N1-N6 = 7-week based grading periods. S1 = 1 st semester S2 = 2 nd semester F = Year



Excel Column Reference	Column Heading	Description	Notes
			T ₁ = 1 st trimester T ₂ = 2 nd trimester T ₃ = 3 rd trimester
J	Grade	Letter Grade or Percent-based Grade (0-100)	Examples: A, B, F, 75, 83, 98, 100



STANDARDIZED STATE TEST IMPORT

Examples of standardized state test are EOG, EOC, and PSAT

(Columns in red are required)

Excel Column Reference	Column Heading	Description	Notes
A	Student ID	This is the student's student ID (state or LEA)	
B	Last Name		
C	First Name		
D	Birth Date		Excel Data Type: Date
E	School ID	NCES School Identification Number	This is the number assigned by the National Center for Education Statistics. See Search for Public Schools - https://nces.ed.gov/ccd/schoolsearch/
F	Test Name	Name of test or assessment	
G	Test Component	Name of the test component being scored	
H	Score	Score attained by student in test component	



ATTENDANCE IMPORT

(Columns in red are required)

Important: The numbers reported for Excused Absences, Unexcused Absences, and Disciplinary Actions should *always* be the year-to-date, whole-day absence totals, i.e., the total whole-day absences since the beginning of the school year. Absences should not be reported by class period.

Excel Column Reference	Column Heading	Description	Notes
A	Student ID	This is the student's unique student ID number (issued by the school, LEA, or state)	
B	Last Name		
C	First Name		
D	Birth Date		Excel Data Type: Date
E	School ID	NCES School Identification Number or other unique Federal ID. This number should match the School ID configured in Pi.	
F	Excused Absences	Year-to-Date number of excused daily absences	Absences should be "day" absences, i.e., not class period absences.
G	Unexcused Absences	Year-to-Date number of unexcused daily absences	Absences should be "day" absences, i.e., not class period absences.
H	Disciplinary Actions	Year-to-Date number of disciplinary actions	

**AGREEMENT BETWEEN
WASHINGTON COUNTY SCHOOLS
AND
EAST TENNESSEE STATE UNIVERSITY**

This Agreement is by and between Washington County Schools, 405 W College Street, Jonesborough, TN 37659 (“COUNTY” or “Partner LEA”) and East Tennessee State University, 1276 Gilbreath Drive, Johnson City, TN, 37614 (“ETSU”), singularly “Party,” and together, “Parties.”

NOW, THEREFORE, in consideration of the covenants and conditions hereinafter set forth and other good and valuable consideration, the receipt and sufficiency of which is acknowledged by each Party by affixing signature hereto, the Parties agree as follows:

- A. COUNTY agrees to perform the services outlined in the Statement of Work (Exhibit A) as part of ETSU’s grant from the U.S. Department of Education (“Prime Award”) for the ETSU GEAR UP project (“Project”), led by ETSU Principal Investigator Dr. Ronnie Gross.
- B. ETSU agrees to compensate COUNTY as follows for those services:
 - 1. The amount as outlined in the Budget (Exhibit B).
 - 2. Payments to COUNTY shall be made upon submittal of invoices by COUNTY and after performance of the portion of the services which the invoiced amount represents. The final payment shall be made only after COUNTY has completely performed its duties under this Agreement.
 - 3. COUNTY shall submit invoices no more frequently than monthly for the services provided.
 - 4. COUNTY shall include appropriate backup documentation with its invoices.
 - 5. ETSU shall, upon timely receipt of COUNTY’s invoice and backup documentation, reimburse COUNTY for such allowable amounts, within 30 days of receipt.
- C. COUNTY will submit reports to ETSU during the Project period as follows:
 - 1. Technical/progress reports and/or financial may be required by ETSU in order for ETSU to satisfy its reporting obligations on the Prime Award. In such instances, COUNTY shall submit a report to ETSU within 60 days of request by ETSU.
 - 2. Annual technical/progress reports shall be submitted within 60 days prior to the end of each budget period to Dr. Gross. Such report shall also note whether there are any changes to the upcoming budget period.
 - 3. A Final technical/progress report shall be submitted within 60 days of the end of the Project period or after termination of the award, whichever comes first, to Dr. Gross.
- D. The term of this agreement shall be from October 1, 2025, through September 30, 2032. The Parties may agree to extend the term by mutual written agreement.
- E. COUNTY certifies that it will perform its work on the Project in accordance with the terms and conditions of this Agreement and the applicable terms of the Prime Award, including the terms and conditions of the federal awarding agency.
- F. The Parties further agree that the following shall be essential terms and conditions of this Agreement.
 - 1. OFFICIAL SIGNATURE. Neither Party shall be bound by this Agreement until it is approved and signed by the appropriate official(s) indicated on the signature page of this Agreement.
 - 2. TERMINATION FOR CONVENIENCE. Either Party may terminate this Agreement by giving the other Party at least 30 days’ written notice before the effective termination date. COUNTY shall be entitled to receive equitable compensation for satisfactory authorized work completed and for non-cancellable obligations incurred as of the termination date.

3. TRAVEL. Unless otherwise indicated in the Agreement, if this Agreement provides for reimbursement for travel, meals, or lodging, such reimbursement must be made in accordance with the travel policies of COUNTY and ETSU.
4. RECORD KEEPING. COUNTY shall maintain documentation for all charges against ETSU under this Agreement. COUNTY's books, records and documents, insofar as they relate to work performed or money received under this Agreement, shall be maintained for a period of three full years from the date of final payment, and shall be subject to audit, at any reasonable time, upon reasonable notice, and at the expense of ETSU. These records shall be maintained in accordance with generally accepted accounting principles.
5. PUBLICATION. The Parties acknowledge that ETSU's policies and mission encourage the publication and / or other dissemination of information created pursuant to all of its work. Subject to the provisions of the other sections of this Agreement, the Parties acknowledge that nothing herein shall prohibit, limit, or interfere with ETSU's rights to publish or present the methods and results of the project.
6. CONDUCT. This Agreement is intended to support the sharing of research within the scientific community. ETSU, through the Principal Investigator, is solely responsible for the conduct, quality and scientific integrity of any research, and retains control over the conduct of any research, including, without limitation, the obligations to assure that the research has been conducted in accordance with all applicable laws, rules, and regulations.
7. INTELLECTUAL PROPERTY. The Parties acknowledge that all intellectual property developed by either Party prior to the Effective Date or outside of the scope of this Agreement is the property of said Party. The Parties acknowledge that during the course of the performance of this Agreement, intellectual property may be generated by COUNTY personnel alone or jointly with ETSU personnel. The following terms concerning intellectual property and inventions shall apply to this Agreement:

7.1 All rights and title to inventions and intellectual property, including, without limitation, copyrights, trademarks, patents, patent disclosures and inventions (whether patentable or not) developed in the course of this project shall be apportioned according to each Party's role in developing the same. All right and title to any final deliverables that are developed for or delivered to ETSU under this Agreement shall belong to ETSU.

7.2 ETSU hereby grants to COUNTY a non-exclusive, fully paid, royalty-free, world-wide license as to its interest in all intellectual property developed under this Agreement for non-commercial research, publication, dissemination, and teaching purposes by COUNTY.

8. CONFIDENTIALITY REVIEW. ETSU shall furnish copies of any proposed publication or other dissemination to COUNTY at least thirty 30 days in advance of the submission of such proposed publication or presentation. COUNTY shall have 30 days from the date on which notice is received to determine whether the proposed publication or other dissemination contains any of its Confidential Information. ETSU agrees, upon written request from COUNTY, to remove any such Confidential Information of COUNTY prior to publication or dissemination. ETSU shall otherwise have full control over all publication and / or dissemination materials.
9. CONFIDENTIAL INFORMATION. Confidential Information is information of a Party, which is disclosed in writing and clearly marked "Confidential" or "Proprietary", or if disclosed orally and identified as confidential at the time, is thereafter reduced to writing by the disclosing Party, clearly marked "Confidential" or "Proprietary" and transmitted to the receiving Party within 30 days after oral disclosure.

9.1 Confidential Information shall not include information that the receiving Party can demonstrate by documentary evidence (i) was, at the time of disclosure, in the public knowledge; (ii) became part of the public knowledge by publication or otherwise, except by breach of a duty by the receiving Party; (iii) was in the possession of the receiving Party at the time of disclosure; (iv) was received from an unrelated third

party, provided such information was not disclosed, to the receiving Party's knowledge, by said third party, directly or indirectly, in violation of any duty of confidentiality; or (v) that is independently developed by the receiving Party's employees or agents who are not privy to the disclosing Party's Confidential Information.

9.2 Nothing in this agreement shall prevent the Parties from disclosing any information, Confidential or otherwise, where they are required to do so by law, order of a Court, government agency, or otherwise pursuant to Tennessee's Public Records laws (T.C.A. Title 10, Chapter 7, as modified by § 49-7-120).

9.2.1 Either Party required to disclose the Confidential Information of the other Party shall notify the other Party, as soon as and to the extent practicable, in advance of any such disclosure of Confidential Information to enable the other Party to take, at the other Party's expense, any appropriate actions as the other Party sees fit under the circumstances, including but not limited to, for example, the seeking of a protective order.

10. ASSIGNMENT AND SUBAGREEMENT. Except as by operation of law, the Parties shall not assign this Agreement or enter into a sub-agreement for any of the services performed under this Agreement without obtaining the prior written approval of the other Party.
11. AUTHORITY. Each Party represents to the other that it has the right to enter into this Agreement without breaching or violating any fiduciary, contractual, or statutory obligations owed to another.
12. NOTICE. Unless otherwise specified in writing, any notice or submission required to be given to a Party under this Agreement shall be made in writing to the Party's authorized representative, indicated below, at the address provided above. Notice shall be effected by electronic mail, or by first class mail, postage prepaid, and return receipt requested, or by overnight courier capable of confirming delivery, and shall be deemed sufficiently given if and when received by the Party to be notified.
13. AMENDMENT. This Agreement may be modified, renewed or otherwise amended only by the written mutual consent of the Parties.
14. COMPLIANCE. The Parties shall comply with all applicable federal and state laws and regulations in the performance of this Agreement.
15. GOVERNING LAW. This Agreement shall be governed by the laws of the State of Tennessee.
16. INSURANCE. The State of Tennessee self-insures its exposures in general liability, automobile liability, professional malpractice and workers' compensation. The State's self-insurance program insures all liability created under Chapter 9, Title 8 of the T.C.A. for all State departments, agencies and institutions, including State institutions of higher education. The State of Tennessee prohibits ETSU from providing, carrying, or maintaining commercial general liability insurance or medical, professional or hospital liability insurance.
17. RESPONSIBILITY. Neither Party shall be responsible for personal injury or property damage or other loss except that resulting from its own negligence or the negligence of its employees or others for whom the Party is legally responsible.
18. CLAIMS. Any and all claims against the State, including ETSU or its employees, including any related to the performance of any responsibility specifically required under this Agreement or any contract, subcontract, or subaward, shall be submitted to the Tennessee Board of Claims or the Tennessee Claims Commission. Damages recoverable against ETSU shall be expressly limited to those claims paid by the Claims Commission pursuant to T.C.A. Section 9-8-301 et seq.
19. NON-DISCRIMINATION. The Parties agree that all policies, standards, and practices contained in the Agreement will be in full compliance with Title VI and VII of the Civil Rights Act of 1964 (P.L. 88-352),

Title IX of the Education Amendments of 1972, Section 504 of the Rehabilitation Act of 1973, Executive Order II, 246, The American Disabilities Act of 1990, and Part 80 of Title 40, Code of Federal Regulations, so that no person will be excluded from participation in, be denied benefits of, or otherwise be subjected to discrimination on the grounds of race, religion, creed, color, sex, gender, orientation, disability, veteran status, or national origin in the performance of this Agreement.

20. **USE OF NAME.** Neither Party shall use the other Party's name, trademarks, or other logos in any publicity, advertising, or news release without the prior written approval of an authorized representative of that Party. The Parties agree that either Party may use factual information regarding the existence and purpose of the relationship that is the subject of this Agreement for legitimate business purposes, to satisfy any reporting and funding obligations, or as required by applicable law or regulation without written permission from the other Party. In any such statement, the relationship of the Parties shall be accurately and appropriately described.
21. **ENTIRE AGREEMENT.** This Agreement embodies the entire understanding between the Parties and supersedes and replaces any and all prior understandings, arrangements, and/or agreements, whether written or oral relating to the Statement of Work. Further, the Parties agree that this Agreement shall be binding upon and inure to the benefit of the Parties hereto and their respective successors and assigns.
22. **SEVERABILITY.** This Agreement is divisible and separable so that if any provision or provisions hereof shall be held to be invalid or if any provision hereof is held to be too broad to be enforced, such provision shall be construed to create an obligation to the full extent allowable by law, such that any such provision or provisions shall not impair the remaining provisions hereof, though only to the extent that such construction does not otherwise defeat the intents of the Parties.
23. **INDEPENDENT PARTIES.** The Parties hereto, in the performance of this Agreement, shall not act as employees, partners, joint venturers, or associates of one another. It is expressly acknowledged by the Parties hereto that such Parties are independent contracting entities and that nothing in this Agreement shall be construed to create an employer/employee relationship or to allow either to exercise control or direction over the manner or method by which the other transacts its business affairs or provides its usual services. The employees or agents of one Party shall not be deemed or construed to be the employees or agents of the other Party for any purpose whatsoever.
24. **WAIVER.** No waiver of any term, provision, or condition of this Agreement, whether by conduct or otherwise, in any one or more instances shall be or shall be construed as a further or continuing waiver of such term, provision, or condition.

IN WITNESS WHEREOF, the parties hereto caused this Agreement to be duly executed by their duly authorized representatives.

EAST TENNESSEE STATE UNIVERSITY

By: Nicholas E. Hagemeier
Digitally signed by Nicholas E. Hagemeier
Date: 2026.02.06 13:46:46 -05'00'

Dr. Nicholas E. Hagemeier
Vice Provost for Research

WASHINGTON COUNTY SCHOOLS

By: 

Name: Jerry S. Boyd
Title: Superintendent of Schools
Date: 2-04-2026

EXHIBIT A – SCOPE OF WORK

Partner LEA will provide student and family programming, professional development, and an LEA Leader for this project. ETSU will reimburse Partner LEA for these activities as follows: (i) a base amount of \$12,000 to cover salary and benefits for 10% of the LEA Leader's time, and (ii) minimum of \$60,000 for student programming, which will be adjusted based upon student population. Specific activities and deliverables are outlined below.

1. Leadership
 - Appoint an LEA GEAR UP Leader (10% FTE) to serve as liaison between LEA and ETSU GEAR UP office.
 - Coordinate LEA-level activities and support implementation of GEAR UP services.
 - Participate on ETSU GEAR UP Advisory Board.
 - Assist with fiscal oversight and compliance for sub-award funds.
2. Annual Workplan Development
 - Develop and submit a comprehensive workplan for each target school by the established deadline.
 - Include services, timelines, and measurable objectives aligned with GEAR UP goals.
 - Engage stakeholders in review and feedback before final approval.
 - Update workplans annually based on evaluation data and program priorities.
3. Student and Family Programming
 - Implement activities funded by GEAR UP including college visits, career exploration, leadership programs, academic support, and FAFSA workshops.
 - Ensure programming aligns with the Think, Know, Act, Go framework.
4. Professional Development
 - Provide release time for faculty and staff to attend GEAR UP-sponsored professional development.
 - Collaborate with ETSU GEAR UP to schedule sessions focused on college-going culture and academic rigor.
5. Facilities and Resources
 - Provide office space for ETSU-hired Site Coordinators and access to necessary technology.
 - Make buses available for student travel to college visits and career events.
 - Support transition programs and other in-kind contributions.
6. Fiscal Accountability
 - Maintain financial oversight and compliance with federal and ETSU GEAR UP regulations.
 - Submit reimbursement requests with required documentation according to ETSU timelines.
 - Participate in annual fiscal audits and monitoring visits.
7. Advisory Board Participation
 - Ensure LEA representation at quarterly ETSU GEAR UP Advisory Board meetings.
 - Contribute to discussions on program implementation, evaluation, and sustainability.
8. Data and Evaluation
 - Provide timely student-level data for evaluation purposes.
 - Participate in surveys, focus groups, and other evaluation activities as requested.
 - Use evaluation feedback to improve services and update workplans.

9. Support for Reporting Requirements

- Support the annual reporting of GEAR UP activities and services that is required by the U.S. Department of Education by providing attendance rosters and sign-in sheets for all GEAR UP activities. ETSU GEAR UP tracks all activities provided to students, families, and professionals. For example, if a GEAR UP workshop occurs where participants gather at school in the evening, eat dinner, and discuss the college application process, a sign-in sheet would be needed to document and track the students served.

10. Graduate Tracking

- Provide a yearly list of high school graduates from GEAR UP schools, including First Name, Last Name, and Date of Birth. This will allow ETSU GEAR UP to begin tracking postsecondary enrollment in the coming years and assess whether GEAR UP increases college-going rates.

11. Compliance and Reporting

- Adhere to all federal, state, and ETSU GEAR UP policies, including FERPA and EDGAR requirements.
- Submit required reports and documentation by established deadlines.

12. Funding Formula

- Each LEA will receive \$12,000 for LEA Leader stipend and benefits.
- Minimum \$60,000 for student programming, adjusted by student population.
- Funds must be used exclusively for approved GEAR UP activities and cannot supplant existing programs.

EXHIBIT B – BUDGET

The anticipated annual funds to be provided for the term of this Agreement, covering the first five years of the ETSU GEAR UP program, are as follows:

Year 1 (FY26)	Year 2 (FY27)	Year 3 (FY28)	Year 4 (FY29)	Year 5 (FY30)
\$122,373	\$122,373	\$122,373	\$122,373	\$122,373

The planned budget for each annual period will be the same and will be as follows:

Category	Amount	Sub-Totals/Total
Yearly Grand Total		\$122,373

ETSU reserves the right to review and adjust annual funding allocations based on evolving strategic priorities, demonstrated program performance, and availability of federal funds. Any adjustments will be communicated in writing to the LEA with a minimum of 60 days’ notice prior to implementation. Adjustments will be made in consultation with the LEA to ensure alignment with approved workplans and GEAR UP objectives.

FDP Data Transfer and Use Agreement (“Agreement”)	
Provider: Washington County Schools	Recipient: East Tennessee State University
Provider Scientist Name: Twana McKinney Email: mckinneyt@wcde.org	Recipient Scientist Name: Ronnie Gross Email: grossrd@etsu.edu
Project Title: ETSU GEAR UP	
Agreement Term Start Date: October 1, 2025 End Date: (choose one) <input type="checkbox"/> 1) ___ years after the Start Date; <input checked="" type="checkbox"/> 2) Completion of the Project; or <input type="checkbox"/> 3) ___ years after the Start Date or upon completion of the project, whichever occurs first.	
Attachment 2 Type: Personally Identifiable Information - FERPA	
Terms and Conditions	
1) Reimbursement of Costs: If applicable, Recipient shall reimburse Provider for any costs associated with the preparation, compilation, and transfer of the Data to the Recipient. Costs shall not include payments for research effort by the Provider. <input checked="" type="checkbox"/> None <input type="checkbox"/> This Agreement is in support of agreement # _____, which shall cover reimbursement of costs. In the event of any conflict of terms, this Agreement shall control regarding issues of data transfer and use. <input type="checkbox"/> As set forth herein:	
2) Provider shall provide the data set described in Attachment 1 (the “Data”) to Recipient for the research purpose set forth in Attachment 1 (the “Project”). Provider shall retain ownership of any rights it may have in the Data, and Recipient does not obtain any rights in the Data other than as set forth herein.	
3) Recipient shall not use the Data except as authorized under this Agreement. The Data will be used solely to conduct the Project and solely by Recipient Scientist and Recipient’s faculty, employees, fellows, students, and agents (“Recipient Personnel”) and Collaborator Personnel (as defined in Attachment 3) that have a need to use, or provide a service in respect of, the Data in connection with the Project and whose obligations of use are consistent with the terms of this Agreement (collectively, “Authorized Persons”).	
4) Except as authorized under this Agreement or otherwise required by law, Recipient agrees to retain control over the Data and shall not disclose, release, sell, rent, lease, loan, or otherwise grant access to the Data to any third party, except Authorized Persons, without the prior written consent of Provider. Recipient agrees to establish appropriate administrative, technical, and physical safeguards to prevent unauthorized use of or access to the Data and comply with any other special requirements relating to safeguarding of the Data as may be set forth in Attachment 2.	

Agreement ID: P25-0326

- 5) Recipient agrees to use the Data in compliance with all applicable laws, rules, and regulations, as well as all professional standards applicable to such research.
- 6) Recipient is encouraged to make publicly available the results of the Project. Before Recipient submits a paper or abstract for publication or otherwise intends to publicly disclose information about the results of the Project, the Provider will have thirty (30) days from receipt to review proposed manuscripts and ten (10) days from receipt to review proposed abstracts to ensure that the Data is appropriately protected. Provider may request in writing that the proposed publication or other disclosure be delayed for up to thirty (30) additional days as necessary to protect proprietary information.
- 7) Recipient agrees to recognize the contribution of the Provider as the source of the Data in all written, visual, or oral public disclosures concerning Recipient's research using the Data, as appropriate in accordance with scholarly standards and any specific format that has been indicated in Attachment 1.
- 8) Unless terminated earlier in accordance with this section or extended via a modification in accordance with Section 13, this Agreement shall expire as of the End Date set forth above. Either party may terminate this Agreement with thirty (30) days written notice to the other party's Authorized Official as set forth below. Upon expiration or early termination of this Agreement, Recipient shall follow the disposition instructions provided in Attachment 1, provided, however, that Recipient may retain one (1) copy of the Data to the extent necessary to comply with the records retention requirements:
 - I. under any law, regulation, or Recipient institutional policy, and
 - II. for instances where Data disposal is infeasible, and
 - III. for the purposes of research integrity and verification.

The restrictions set forth in this Agreement (as applicable) shall survive and apply to such archival copy so long as Recipient holds the Data.



- 9) Except as provided below or prohibited by law, any Data delivered pursuant to this Agreement is understood to be provided "AS IS." PROVIDER MAKES NO REPRESENTATIONS AND EXTENDS NO WARRANTIES OF ANY KIND, EITHER EXPRESSED OR IMPLIED. THERE ARE NO EXPRESS OR IMPLIED WARRANTIES OF MERCHANTABILITY OR FITNESS FOR A PARTICULAR PURPOSE, OR THAT THE USE OF THE DATA WILL NOT INFRINGE ANY PATENT, COPYRIGHT, TRADEMARK, OR OTHER PROPRIETARY RIGHTS. Notwithstanding, Provider, to the best of its knowledge and belief, has the right and authority to provide the Data to Recipient for use in the Project.
- 10) Except to the extent prohibited by law, the Recipient assumes all liability for damages which may arise from its use, storage, disclosure, or disposal of the Data. The Provider will not be liable to the Recipient for any loss, claim, or demand made by the Recipient, or made against the Recipient by any other party, due to or arising from the use of the Data by the Recipient, except to the extent permitted by law when caused by the gross negligence or willful misconduct of the Provider. No indemnification for any loss, claim, damage, or liability is intended or provided by either party under this Agreement.
- 11) Neither party shall use the other party's name, trademarks, or other logos in any publicity, advertising, or news release without the prior written approval of an authorized representative of that party. The parties agree that each party may disclose factual information regarding the existence and purpose of the relationship that is the subject of this Agreement for other purposes without written permission from the other party provided that any such statement shall accurately and appropriately describe the relationship of the parties and shall not in any manner imply endorsement by the other party whose name is being used.

12) Unless otherwise specified, this Agreement and the below listed Attachments embody the entire understanding between Provider and Recipient regarding the transfer of the Data to Recipient for the Project:

- I. Attachment 1: Project Specific Information
- II. Attachment 2: Data-specific Terms and Conditions
- III. Attachment 3: Identification of Permitted Collaborators (if any)

13) No modification or waiver of this Agreement shall be valid unless in writing and executed by duly-authorized representatives of both parties.

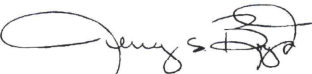
14) The undersigned Authorized Officials of Provider and Recipient expressly represent and affirm that the contents of any statements made herein are truthful and accurate and that they are duly authorized to sign this Agreement on behalf of their institution.

<p>By an Authorized Official of Provider:</p> 	<p>By an Authorized Official of Recipient:</p> <p>Nicholas E. Hagemeyer</p>  <p>Digitally signed by Nicholas E. Hagemeyer Date: 2026.02.06 16:20:40 -05'00'</p>
<p style="text-align: right;">Date</p> <p>Name: Jerry S. Boyd Title: Superintendent of Schools</p>	<p style="text-align: right;">Date</p> <p>Name: Nicholas E. Hagemeyer Title: Vice Provost for Research</p>
<p><u>Contact Information for Formal Notices:</u></p> <p>Name: Twana McKinney Address: 405 W. College Street Jonesborough, TN 37659</p> <p>Email: mckinneyt@wcde.org Phone: 423-753-1100</p>	<p><u>Contact Information for Formal Notices:</u></p> <p>Name: Rachel A. Bishop Address: PO Box 70565 Johnson City, TN 37614</p> <p>Email: bishopra1@etsu.edu Phone: 423-439-6045</p>

Attachment 1
Data Transfer and Use Agreement
Project Specific Information

1. Description of Data:

Data will be shared in relation to the ETSU GEAR UP grant. Recipient is the prime awardee, and the grant has been awarded by the U.S. Department of Education.

The data points included in Exhibit A to this Data Transfer and Use Agreement will be transferred to Recipient and to third-party entity Vela Institute. Provider will provide data relating to students attending its schools. Provider will create export reports and will provide the data following this collection schedule: September, January, and June for each year of the grant program.

Provider will also share sign-in sheets for all GEAR UP activities as well as a yearly list of high school graduates from GEAR UP schools, including First Name, Last Name, and Date of Birth.

Provider will also collaborate with Recipient to administer surveys to students relating to pre-treatment college knowledge and pre-treatment FAFSA completions and college applications. These surveys will be administered through Qualtrics and will be shared for completion at least annually.

2. Description of Project:

The GEAR UP program provides financial and academic assistance and support, mentoring, and outreach to students with an aim to increase the number of low-income and first-generation students who are prepared to enroll and succeed in college. ETSU GEAR UP will serve 5,198 students in six low income Local Education Agencies (LEAs) across East TN during the seven-year grant period. Services will be provided to two cohorts of students. ETSU GEAR UP's project design is Think, Know, Act, Go: Educational Attainment and Economic Mobility. The design is grounded in the seminal college readiness work of David Conley. Adapting Conley's framework, four themes guide implementation and services: College-Going Culture (Think), Financial Literacy (Know), Academic Advising (Act), Postsecondary and Career Preparation (Go). ETSU GEAR UP provides required and permissible activities: tutoring, academic advising and counseling, dual-enrollment, college planning and financial aid workshops, mentoring, college visits, summer programming, non-cognitive skill development, financial literacy, college transition support to 7th year cohort students, and professional development to educators.

A collaborative evaluation approach with Vela Institute and ETSU research faculty will produce high quality evaluation. To meet project objectives, ETSU GEAR UP will use data to guide services, maximizing project effectiveness in meeting the needs of target LEA students and their families. Student-level data, housed in the Vela Institute's Performance Insights (Pi) database, allows for rigorous evaluation that includes longitudinal analyses of student outcomes, identification and replication of effective instructional practices, and continuous improvement of service implementation to meet program objectives, evaluate the program, and conduct a quasi-experimental research study.

Attachment 1
Data Transfer and Use Agreement
Project Specific Information

3. Provider Support and Data Transmission:

Provider shall transmit the Data to Recipient: Electronically (description below)

Name:	Ronnie Gross
Address:	Electronic transfer of data
Email:	grossrd@etsu.edu
Phone:	423-439-4002

Upon execution of this Agreement, Provider shall send any specific instructions necessary to complete the transfer of the Data to the contact person listed above, if not already included below in this section of Attachment 1.

Provider will directly share data through Vela Institute's Performance Insights (Pi) database, which pulls data directly from the Providers's student information systems. The transfer of the data and the Pi database are secured through HECVAT Lite. ETSU GEAR UP staff and Vela Institute staff will have access to the data. Data will also be shared with Recipient through ShareFile. The data will only be shared with others in aggregate, de-identified form, summarized through descriptive statistics.

Survey data generated in collaboration with Provider will be collected through Qualtrics, then stored either in the Pi database or on ETSU's OneDrive for Business.

4. Disposition Requirements upon the termination or expiration of the Agreement:

Upon expiration or early termination of this agreement, Recipient may retain one copy of the Data, in a secure location or database, to comply with records retention requirements, for the purposes of research integrity and verification, and/or for audit purposes. Recipient shall delete Data stored elsewhere.

Agreement ID: P25-0326

Attachment 2
Data Transfer and Use Agreement
Data-specific Terms and Conditions:
Personally Identifiable Information - FERPA

Additional Terms and Conditions:

1. The Data is Personally Identifiable Information, as that is defined in the Family Education Rights and Privacy Act of 1974 at 20 U.S.C. §1232(g) and regulations at 34 C.F.R. §99.3 (collectively, "FERPA") and is further categorized as Education Records and/or Treatment Records as those terms are defined in FERPA.
 - If checked, the Data is covered under a Certificate of Confidentiality, which must be asserted against compulsory legal demands, such as court orders and subpoenas for identifying information or characteristics of a research participant. See <https://grants.nih.gov/grants/guide/notice-files/NOT-OD-17-109.html> for further information.
2. Notwithstanding any statement herein to the contrary and pursuant to 34 CFR §99.31(a)(6), Provider represents that it has full authority to share the Data with the Recipient for the Project.
3. Unless otherwise required by law or legal process, Recipient shall not use or further disclose the Data other than as permitted by this Agreement. If Recipient believes it is required by law or legal process to use or disclose the Data, it will promptly notify Provider, to the extent allowed by law, prior to such use or disclosure and will disclose the least possible amount of Data necessary to fulfill its legal obligations.
4. In the event Recipient becomes aware of any use or disclosure of the Data not provided for by this Agreement, Recipient shall take any appropriate steps to minimize the impact of such unauthorized use or disclosure as soon as practicable and shall notify Provider of such use or disclosure as soon as possible, but no later than 5 business days after discovery of the unauthorized use or disclosure. Recipient shall cooperate with Provider to investigate, correct, and/or mitigate such unauthorized use or disclosure. Recipient acknowledges that Provider may have an obligation to make further notifications under applicable state law and shall cooperate with the Provider to the extent necessary to enable Provider to meet all such obligations.
5. Recipient will not use the Data, either alone or in concert with any other information, to make any effort to contact individuals who are the subjects of the Data without appropriate Institutional Review Board (IRB) approval, specific written approval from Provider, and informed consent and authorization from the individual or a waiver, if required.
6. Recipient agrees to store Data with security controls adequate to protect Personally Identifiable Information, to ensure that only Authorized Persons have access to the Data, and to maintain appropriate control over the Data at all times.
7. Pursuant to 34 CFR §99, Recipient agrees to remove and securely destroy, as directed by the Provider in Attachment 1, the Personally Identifiable Information at the earliest time at which removal and destruction can be accomplished consistent with the Project.
8. By signing this Agreement, Recipient provides assurance that its relevant institutional policies and applicable federal, state, or local laws and regulations (if any) have been followed, including the completion of any IRB review or approval that may be required prior to Recipient's use of the Data. Upon Provider's written request to the Recipient's Contact for Formal Notices identified in the signature block, Recipient shall provide documentation of its IRB-Approved Protocol.

Agreement ID: P25-0326

Attachment 3
Data Transfer and Use Agreement
Identification of Permitted Collaborators (if any)

For all purposes of this Agreement, the definition of “Collaborator Personnel” checked below will pertain:

“Collaborator Personnel” means: None. No third-party collaborators are permitted on the Project. All Authorized Persons using the Data are Recipient Personnel.

-OR-

“Collaborator Personnel” means the third parties as set forth below and agreed upon between the Parties. To be clear, Collaborator Personnel are not Recipient Personnel.

“Collaborator Personnel” means: employees third-party non-profit institution, Vela Institute, which institution (i) has agreed to collaborate on the Project, (ii) has employees who have a need to use or provide a service with respect to the Data in connection with its collaboration on the Project, and (iii) has been made aware of the terms of this Agreement and has agreed to comply, and to cause its personnel to comply, with such terms.



DEMOGRAPHICS IMPORT

(Columns in red are required)

Excel Column Reference	Column Heading	Description	Notes
A	Last Name	Student's Last Name	
B	First Name	Student's First Name	
C	Middle Name	Student's Middle Name	Middle name initial or full middle name
D	Suffix	Student's Suffix	Ex: Jr, II, Junior, III
E	Birth Date	Student's Date of Birth	Excel Data Type: Date
F	Gender	Student's Gender	F = Female M = Male NB = Nonbinary U = Unknown O = Other (deprecated) GN = Gender Neutral (deprecated) Blank cells or cells with value of O in this column will be converted to the value Unknown (U) Cells with a value of GN will be converted to Nonbinary (NB)
G	Race	Student's Race code	I = American Indian or Alaskan Native A = Asian B = Black or African American P = Native Hawaiian or Pacific Islander



Excel Column Reference	Column Heading	Description	Notes
			W = White M = Two or More Races
H	Ethnicity	Student's Ethnicity code	N = Non-Hispanic H = Hispanic Blank cells in this column will be converted to the value N.
I	Street 1	The street number and name of Student's address	
J	Street 2	Student's Apartment Number	
K	City	City where student resides	
L	State	State	Two-character state code
M	Zip	Zip code	
N	Phone	Student's Cell Phone Number (if unknown leave blank)	
O	Email	Student's Email Address (if unknown leave blank)	
P	Grade	Student's Grade Level	
Q	Student ID	This is the student's unique student ID number (issued by the school, LEA, or state)	
R	School ID	NCES School Identification Number. This number should match the School ID configured in Pi.	This is the number assigned by the National Center for Education Statistics. See Search for Public Schools - https://nces.ed.gov/ccd/schoolsearch/



Excel Column Reference	Column Heading	Description	Notes
S	LEA ID	NCES LEA Identification Number. This number should match the LEA ID configured in Pi for the school.	This is the number assigned by the National Center for Education Statistics. See Search for Public School Districts - https://nces.ed.gov/ccd/districtsearch/
T	HS GPA ^a	Student's cumulative GPA	
U	HS Grad Date	Date on which student graduated from High School	Excel Data Type: Date
V	LEP	Is the student a Limited English Proficiency student?	Y = LEP flag on N = LEP flag off Blank cells in this column will be converted to the value N.
W	IEP	Does student have an Individualized Education Plan?	Y = IEP flag on N = IEP flag off Blank cells in this column will be converted to the value N.
X	Foster Care	Does student live in a foster care system (ward, group home, private home)?	Y = Yes N = No Blank cells in this column will be converted to the value N.
Y	Homeless	Is student currently homeless (not in foster care or with parents)?	Y = Yes N = No



Excel Column Reference	Column Heading	Description	Notes
			Blank cells in this column will be converted to the value N.
Z	Mother Name	Student's Mother's Name	
AA	Mother Phone	Student's Mother's Cell Phone	
AB	Mother Email	Student's Mother's Email	
AC	Father Name	Student's Father's Name	
AD	Father Phone	Student's Father's Cell Phone	
AE	Father Email	Student's Father's Email	
AF	Guardian Name	Student's Guardian's Name	
AG	Guardian Phone	Student's Guardian's Cell Phone	
AH	Guardian Email	Student's Guardian's Email	
AI	Earned Credits	Student's cumulative number of credits earned	
AJ	Student Type ^b	Specifies whether the student is a Priority student or a Cohort student.	C = Cohort P = Priority

^a A value is required if your program is a CCREC member program, and the student is in grade 9th, 10th, 11th, or 12th. Or, if your evaluation plan requires it. Please ensure with your evaluator the need for this field.

^b A valid value is required if your program is a CCREC member program, and if it is a hybrid or mixed program serving students on both cohort and priority basis.



ACADEMIC IMPORT

The academic Import file should include only those grades, i.e., marks, which are coded as final. In other words, only grades that contributed to the student's earned credits/hours figure but also including failing grades that although final, failed to yield a credit/hour figure for the student.

(Columns in red are required)

Excel Column Reference	Column Heading	Description	Notes
A	Student ID	This is the student's unique student ID number (issued by the school, LEA, or state)	
B	Last Name		
C	First Name		
D	Birth Date		Excel Data Type: Date
E	School ID	NCES School Identification Number or other unique Federal ID. This number should match the School ID configured in Pi.	This is the number assigned by the National Center for Education Statistics. See Search for Public Schools - https://nces.ed.gov/ccd/schoolsearch/
F	Grade Level	Student's grade level	Examples: 7 = 7 th grade 8 = 8 th grade
G	Course Code		Alphanumeric code for course Maximum 25 characters
H	Course Title		
I	Grading Period	This a code that denotes the schools code for final grade. Some schools record final grades once each semester and usually code them as S1 or S2. A fewer number of schools record a single final grade at the end of the school year. Yet other schools operate on a trimester basis and record final grades 3 times a year, perhaps as T1, T2, and T3	Valid values Q1-Q4 = Quarter-based grades N1-N6 = 7-week based grading periods. S1 = 1 st semester S2 = 2 nd semester F = Year



Excel Column Reference	Column Heading	Description	Notes
			T ₁ = 1 st trimester T ₂ = 2 nd trimester T ₃ = 3 rd trimester
J	Grade	Letter Grade or Percent-based Grade (0-100)	Examples: A, B, F, 75, 83, 98, 100



STANDARDIZED STATE TEST IMPORT

Examples of standardized state test are EOG, EOC, and PSAT

(Columns in red are required)

Excel Column Reference	Column Heading	Description	Notes
A	Student ID	This is the student's student ID (state or LEA)	
B	Last Name		
C	First Name		
D	Birth Date		Excel Data Type: Date
E	School ID	NCES School Identification Number	This is the number assigned by the National Center for Education Statistics. See Search for Public Schools - https://nces.ed.gov/ccd/schoolsearch/
F	Test Name	Name of test or assessment	
G	Test Component	Name of the test component being scored	
H	Score	Score attained by student in test component	



ATTENDANCE IMPORT

(Columns in red are required)

Important: The numbers reported for Excused Absences, Unexcused Absences, and Disciplinary Actions should *always* be the year-to-date, whole-day absence totals, i.e., the total whole-day absences since the beginning of the school year. Absences should not be reported by class period.

Excel Column Reference	Column Heading	Description	Notes
A	Student ID	This is the student's unique student ID number (issued by the school, LEA, or state)	
B	Last Name		
C	First Name		
D	Birth Date		Excel Data Type: Date
E	School ID	NCES School Identification Number or other unique Federal ID. This number should match the School ID configured in Pi.	
F	Excused Absences	Year-to-Date number of excused daily absences	Absences should be "day" absences, i.e., not class period absences.
G	Unexcused Absences	Year-to-Date number of unexcused daily absences	Absences should be "day" absences, i.e., not class period absences.
H	Disciplinary Actions	Year-to-Date number of disciplinary actions	

Gross ETSU Washington County DUA - UE (5)

Final Audit Report

2026-02-06

Created:	2026-02-04
By:	Twana MCKINNEY (mckinneyt@wcde.org)
Status:	Signed
Transaction ID:	CBJCHBCAABAAC1NxtcmnaL3PsPDNlag3MoSRscRkkZr

"Gross ETSU Washington County DUA - UE (5)" History

 Document created by Twana MCKINNEY (mckinneyt@wcde.org)
2026-02-04 - 8:28:08 PM GMT

 Document emailed to Jerry Boyd (boydj@wcde.org) for signature
2026-02-04 - 8:28:58 PM GMT

 Email viewed by Jerry Boyd (boydj@wcde.org)
2026-02-06 - 2:59:32 PM GMT

 Document e-signed by Jerry Boyd (boydj@wcde.org)
Signature Date: 2026-02-06 - 2:59:47 PM GMT - Time Source: server

 Agreement completed.
2026-02-06 - 2:59:47 PM GMT



WASHINGTON COUNTY SCHOOLS

INSPIRE ★ STRIVE ★ THRIVE

Mr. Jerry S. Boyd
Superintendent
Phone (423) 753-1100

405 W. College St.
Jonesborough, TN 37659

Memo: GEAR UP stipend work approval
141 E fund, Program code 350

To: Brad Hale and School Board

The following stipend request is part of the Scope of Work provided by the Leadership in partnership with ETSU GEAR UP program. The program provides 4 Site Coordinators working currently with the 6th and 7th grade cohort. The Site Coordinators will be following this cohort through graduation under the multi-year GEAR UP grant. **The requested stipends will be reimbursed by the GEAR UP grant managed by ETSU TRiO Programs.** GEAR UP is a federally funded program designed to increase the number of students, especially those from underserved backgrounds, who are prepared for, enroll in, and successfully complete postsecondary education through sustained academic support, college and career awareness, and family engagement.

Duties performed by Leadership team:

- Annual Work Plan Development
- Student & Family Programming visibility and activeness support
- Professional development support in staff participation
- Infrastructure to run the program
- Fiscal Accountability for the grant funds to support the program
- Advisory Board Panel participation
- Data & Evaluation, illustrating the proof of impact
- Reporting Support
- Hiring panel with ETSU of the Site Coordinators
- Support Graduation Tracking
- Compliance and Regulations of the data and grant
- Correct and Strategic Use of grant fund

Appropriation code	141E 72130-189 000 00000 350	141E72130- 20100000000350	141E72130- 21200000000350	141E72130- 20400000000350
	GEAR UP GRANT for School Year 25- 26	6.2%	1.45%	9% or 5.77%
Name	Stipend Amount	Social Security	Medicare	Retirement
Kelli Hauldren	\$3,599.87	\$ 223.19	\$ 52.20	\$ 323.99
Cindy Hayes	\$3,549.00	\$ 220.04	\$ 51.46	\$ 204.78
Twana McKinney	\$3,328.62	\$ 206.37	\$ 48.26	\$ 192.06
			total	\$11,999.84

Board of Directors

Eric Barnes
Annette Buchanan
Keith Ervin

Chad Fleenor
David Hammond
Gregg Huddlestone

Mike Masters
Whitney Riddle
Vince Walters

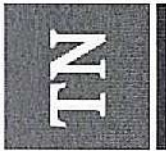

ePlan Home
Search
Reports
Inbox
Planning
Monitoring
Funding
Data and Information Requests
Reimbursement Requests
Project Summary
LEA Document Library
Address Book
TDOE Resources
Help for Current Page
Contact TDOE
ePlan Sign Out

Production Session Timeout (Hide Timer) 00:29:28

Budget Overview

Washington County (900) Public District - FY 2026 - Summer Learning Camps - Rev 0 - Learning Camps

Go To

Filter by Location: All - \$994,939.04
 Show Unbudgeted Categories

Account Number	71100 - Regular Instruction Program	72120 - Health Services	72210 - Support Services/Regular Instruction Program	72410 - Office of the Principal	72710 - Transportation	73100 - Food Service	Total
104 - Principal(s)				16,000.00			16,000.00
105 - Supervisor / Director		0.00	0.00		530.00	0.00	530.00
116 - Teachers	393,338.00						393,338.00
146 - Bus Drivers				52,640.00			52,640.00
163 - Educational Assistants	62,061.60						62,061.60
165 - Cafeteria Personnel						55,000.00	55,000.00
189 - Other Salaries & Wages	0.00	15,000.00	2,000.00	0.00		0.00	17,000.00
201 - Social Security	27,947.82	930.00	124.00	1,000.00	3,300.00	3,410.00	36,711.82
204 - State Retirement	56,257.70	2,000.00	250.00	2,000.00	6,500.00	6,875.00	73,882.70
212 - Employer Medicare	6,530.00	240.00	30.00	240.00	770.00	800.00	8,610.00
338 - Maintenance & Repair Services - Vehicles					50,000.00	0.00	50,000.00

Budget Overview

Account Number	71100 - Regular Instruction Program	72120 - Health Services	72210 - Support Services/Regular Instruction Program	72410 - Office of the Principal	72710 - Transportation	73100 - Food Service	Total
Line Item Number							
412 - Diesel Fuel					35,000.00	0.00	35,000.00
429 - Instructional Supplies & Materials	134,164.92						134,164.92
499 - Other Supplies and Materials	45,000.00	0.00			0.00	0.00	45,000.00
599 - Other Charges	15,000.00	0.00	0.00				15,000.00
Total	740,300.04	18,170.00	2,404.00	19,240.00	148,740.00	66,085.00	994,939.04
					Adjusted Allocation	Remaining	0.00

Go To

Session Timeout
 (Hide Timer)
 00:29:28

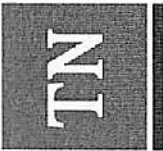

ePlan Home
Search
Reports
Inbox
Planning
Monitoring
Funding
Data and Information Requests
Project Summary
LEA Document Library
Address Book
TDOE Resources
Help for Current Page
Contact TDOE
ePlan Sign Out

Hale, Brad

Production Session Timeout (Hide Timer)
00:29:55

Budget Detail

Washington County (900) Public District - FY 2026 - Summer Learning Camps - Rev 0 - Learning Camps

[Return](#)

Filtering - 20 out of 43 Budget Details match selected filters

[Show All / Clear All](#)

Account Number Line Item Number Location Code Narrative

71100 - Regular Instru... All No Options Selected

[Download Budget Data](#)

[Add Budget Detail](#) << First < Previous 1 | 2 Next > Last >> Items 1-10 out of 20 Items/Page: 10

Delete Edit Budget Detail

Account Number: 71100 - Regular Instruction Program

Line Item Number: 116 - Teachers

Optional Program Code:

Location Code: Washington County (900)

Quantity: 1.00

Cost: \$388,058.00

Line Item Total: \$388,058.00

Account Number: 71100 - Regular Instruction Program

Narrative Description
The estimated cost for instructional teacher wages for the Summer Learning Camp is \$374,

The camp will serve students in rising grades K-9 from all ten K-8 schools in the district and will take place at a centralized location. Approximately 65 certified instructional teachers will be assigned to the camp, working 16 days over 4 weeks, with 7.5 -hour workdays.

Their compensation will be based on their current daily pay rate, totaling an estimated \$374,000

Six teachers will be compensated \$33 per hour for 6 hours of pre-planning time and school safety summer plan with Leadership Team, amounting to \$1,188.

All 65 teachers will receive an additional 6 hours of pre-planning and preparation for their classes, with a total cost of \$12,870 at \$33/hour planning rate.

The estimated total planning cost is \$14,058, bringing the overall budget to \$388,058
65 teacher count at 65 FTE

Estimated wages for 4 CTE teachers at \$5,280.

Four high school CTE teachers will support the STREAM program once a week to strengthen the connection between elementary and high school.

Line Item Number: 116 - Teachers
 Optional Program Code:

Location Code: Washington County (900)

Quantity: 1.00
 Cost: \$5,280.00
 Line Item Total: \$5,280.00

Account Number: 71100 - Regular Instruction Program

Line Item Number: 163 - Educational Assistants

Optional Program Code:

Location Code: Washington County (900)

Quantity: 1.00
 Cost: \$62,061.60
 Line Item Total: \$62,061.60

Account Number: 71100 - Regular Instruction Program

Line Item Number: 201 - Social Security

Optional Program Code:

Location Code: Washington County (900)

Quantity: 1.00
 Cost: \$24,100.00
 Line Item Total: \$24,100.00

Account Number: 71100 - Regular Instruction Program

These teachers will co-teach alongside STREAM instructors, using discussions and hands-on activities to introduce and demonstrate various career opportunities to all students. Wages based on current pay rate.
 4 CTE certified teachers count at .5 FTE

The estimated cost for educational assistant wages for the Summer Learning Camp is \$62,061.60.
 The camp will serve students in rising grades K-9 from all ten K-8 schools in the district and will take place at a centralized location. Approximately 30 educational assistants will be assigned to the camp, working 16 days over 4 weeks, with 7.5-hour workdays. Their compensation will be based on their current daily pay rate, totaling an estimated \$62,061.60.
 30 Non-Certified (Educational Assistants) support count at 30 FTE

Instructional Teachers Social Security estimated at \$24,100(6.2%)
 The estimated cost for 65 instructional teacher wages for the Summer Learning Camp is \$388,058. The camp will serve students in rising grades K-9 from all ten K-8 schools in the district and will take place at a centralized location.
 The estimated cost for Social Security is \$24,100
 65 teacher count at 65 FTE

Educational Assistants Social Security estimated at \$3,847.82(6.2%)
 The estimated cost for 30 educational assistants wages for the Summer Learning Camp is \$62,061.60. The camp will serve students in rising grades

Session Timeout
 (Hide Timer)
 00:29:55

Line Item Number: 201 - Social Security

Optional Program Code:

Location Code: Washington County (900)

Quantity: 1.00

Cost: \$3,847.82

Line Item Total: \$3,847.82

Account Number: 71100 - Regular Instruction Program

Line Item Number: 204 - State Retirement

Optional Program Code:

Location Code: Washington County (900)

Quantity: 1.00

Cost: \$48,500.00

Line Item Total: \$48,500.00

Account Number: 71100 - Regular Instruction Program

Line Item Number: 204 - State Retirement

Optional Program Code:

Location Code: Washington County (900)

Quantity: 1.00

Cost: \$7,757.70

Line Item Total: \$7,757.70

Account Number: 71100 - Regular Instruction Program

Session Timeout (Hide Timer) 00:29:55

K-9 from all ten K-8 schools in the district and will take place at a centralized location.

The estimated cost for Social Security is \$3,847.82

30 educational assistants count at 30 FTE

Instructional Teachers State Retirement estimated at \$48,500 (12.5%)

The estimated cost for 65 instructional teacher wages for the Summer Learning Camp is \$388,068 The camp will serve students in rising grades K-9 from all ten K-8 schools in the district and will take place at a centralized location.

The estimated cost for State Retirement is \$48,500

65 teacher count at 65 FTE

Educational Assistants State Retirement estimated at \$7,757.70(12.5%)

The estimated cost for 30 educational assistants wages for the Summer Learning Camp is \$62,061.60 The camp will serve students in rising grades K-9 from all ten K-8 schools in the district and will take place at a centralized location.

The estimated cost for State Retirement is \$7,757.70

30 educational assistants count at 30 FTE

Instructional Teachers Employee Medicare estimated at \$5,630(1.45%)

The estimated cost for 65 instructional teacher wages for the Summer Learning Camp is \$388,068 The camp will serve students in rising grades

Budget Detail

Line Item Number: 212 - Employer Medicare
 Optional Program Code:
 Location Code: Washington County (900)

Quantity: 1.00
 Cost: \$5,630.00
 Line Item Total: \$5,630.00

Account Number: 71100 - Regular Instruction Program

Line Item Number: 212 - Employer Medicare
 Optional Program Code:
 Location Code: Washington County (900)

Quantity: 1.00
 Cost: \$900.00
 Line Item Total: \$900.00

Account Number: 71100 - Regular Instruction Program

Line Item Number: 429 - Instructional Supplies & Materials
 Optional Program Code:
 Location Code: Washington County (900)

Quantity: 1.00
 Cost: \$43,173.42
 Line Item Total: \$43,173.42

Session Timeout
 (Hide Timer)
 00:29:55

K-9 from all ten K-8 schools in the district and will take place at a centralized location.
 The estimated cost for Employee Medicare is \$5,630
 65 teacher count at 85 FTE

Educational Assistants Employee Medicare estimated at \$7,757.70(1.45%)
 The estimated cost for 30 educational assistants wages for the Summer Learning Camp is \$900.00 The camp will serve students in rising grades K-9 from all ten K-8 schools in the district and will take place at a centralized location.
 The estimated cost for Employee Medicare is \$900.00
 30 FTE educational assistants count

Benchmark Education Steps to Advance Literacy resources that ensure continuous alignment between summer programs and regular school-year instruction for English Language Arts (ELA) in grades 2-5.

Total for filtered Budget Details: \$740,300.04

Total for all other Budget Details: \$254,639.00

Total for all Budget Details:

Adjusted Allocation:

Remaining:

[TN.gov Directory](#) | [Web Policies](#) | [Accessibility](#)
 TN Department of Education | Andrew Johnson Tower | 710 James Robertson Parkway | Nashville, TN 37243 | (629) 395-4684 | ePlan.Help@tn.gov

Session Timeout
 (Hide Timer)
 00:29:55

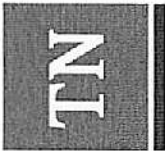

ePlan Home
Search
Reports
Inbox
Planning
Monitoring
Funding
Data and Information
Reimbursement Requests
Project Summary
LEA Document Library
Address Book
TDOE Resources
Help for Current Page
Contact TDOE
ePlan Sign Out

Hale, Brad

Production
Session Timeout (Hide Timer)
00:29:57

Budget Detail

Washington County (900) Public District - FY 2026 - Summer Learning Camps - Rev 0 - Learning Camps

[Return](#)

Filtering - 4 out of 43 Budget Details match selected filters [Show All / Clear All](#)

Account Number	Line Item Number	Location Code	Narrative
72120 - Health Services	All	All	No Options Selected

[Download Budget Data](#)

[Add Budget Detail](#)
[Delete](#)
[Edit](#)
[Budget Detail](#)

<< First < Previous **1** Next > Last >> Items 1-4 out of 4 Items/Page: 10

Account Number: 72120 - Health Services
Line Item Number: 189 - Other Salaries & Wages
Optional Program Code:
Location Code: Washington County (900)
Quantity: 1.00
Cost: \$15,000.00
Line Item Total: \$15,000.00
Account Number: 72120 - Health Services
Line Item Number: 201 - Social Security
Optional Program Code:

Narrative Description

Wages for Nursing Staff estimated at \$ 15,000 three full-time nurses will be available to support the program throughout the duration of the summer program. This includes on-site support and field trip support. The compensation for these nurses will be determined by their current daily pay rate, amounting to an estimated total pay of \$15,000

3 Nurse Count at 3 FTE

Three full-time nurses will be available to support the program throughout the duration of the summer program. This includes on-site support and field trip support. Estimated social security 6.2% at \$930

3 Nurse Count at 3 FTE

Location Code: Washington County (900)

Quantity: 1.00

Cost: \$930.00

Line Item Total: \$930.00

Account Number: 72120 - Health Services

Line Item Number: 204 - State Retirement

Optional Program Code:

Location Code: Washington County (900)

Quantity: 1.00

Cost: \$2,000.00

Line Item Total: \$2,000.00

Account Number: 72120 - Health Services

Line Item Number: 212 - Employer Medicare

Optional Program Code:

Location Code: Washington County (900)

Quantity: 1.00

Cost: \$240.00

Line Item Total: \$240.00

Session Timeout (Hide Timer) 00:29:57

Three full-time nurses will be available to support the program throughout the duration of the summer program. This includes on-site support and field trip support. Estimated state retirement at 12.5% \$2000.
3 Nurse Count at 3 FTE

Three full-time nurses will be available to support the program throughout the duration of the summer program. This includes on-site support and field trip support. Estimated employer Medicare at 1.45 % \$240.
3 Nurse Count at 3 FTE

Total for filtered Budget Details: \$18,170.00
Total for all other Budget Details: \$976,769.04
Total for all Budget Details: \$994,939.04
Adjusted Allocation: \$994,939.04
Remaining: \$0.00

[Return](#)

[TN.gov Directory](#) | [Web Policies](#) | [Accessibility](#)
TN Department of Education | Andrew Johnson Tower | 710 James Robertson Parkway | Nashville, TN 37243 | (629) 395-4684 | ePlan.Help@tn.gov

Session Timeout
(Hide Timer)
00:29:57

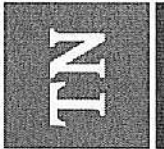

ePlan Home
Search
Reports
Inbox
Planning
Monitoring
Funding
Data and Information
Reimbursement
Requests
Project Summary
LEA Document Library
Address Book
TDOE Resources
Help for Current Page
Contact TDOE
ePlan Sign Out

Hale, Brad

Production
Session Timeout (Hide Timer)
00:29:58

Budget Detail

Washington County (900) Public District - FY 2026 - Summer Learning Camps - Rev 0 - Learning Camps

[Return](#)

Filtering - 4 out of 43 Budget Details match selected filters

Show All / Clear All

Account Number Line Item Number Location Code Narrative

72210 - Support Serv... All All No Options Selected

[Download Budget Data](#)

[Add Budget Detail](#) << First < Previous **1** Next > Last >> Items 1-4 out of 4 Items/Page: 10

Delete Edit Budget Detail

<p>Account Number: 72210 - Support Services/Regular Instruction</p> <p>Line Item Number: 189 - Other Salaries & Wages</p> <p>Optional Program Code:</p> <p>Location Code: Washington County (900)</p> <p>Quantity: 1.00</p> <p>Cost: \$2,000.00</p> <p>Line Item Total: \$2,000.00</p>	<p>Narrative Description</p> <p>RTI teacher Supervisor wages at \$2,000</p> <p>An RTI supervisor will be assigned to support pre-planning and training for all RTI educators participating in the summer program. Responsibilities will include reviewing the list of registered students and identifying their individual support needs to effectively communicate these to the assigned summer RTI instructors.</p> <p>The supervisor will conduct pre-program training and provide ongoing support throughout the duration of the program. This support will ensure that students' individual needs are addressed and that proper documentation is collected to inform instruction for the upcoming school year.</p> <p>1 RTI teacher Supervisor count at 1 FTE</p>
---	---

1 RTI teacher Supervisor count at 1 FTE

<p>Account Number: 72210 - Support Services/Regular Instruction</p> <p>Line Item Number: 201 - Social Security</p> <p>Optional Program Code:</p>	<p>Narrative Description</p> <p>RTI teacher Supervisor estimated Social Security (6.2%)</p> <p>\$124 RTI teacher Supervisor wages at \$2,000 An RTI supervisor will be assigned to support pre-planning and training for all RTI educators participating in the summer program. Responsibilities will include reviewing the list of registered students and identifying their individual support needs to effectively communicate these to the assigned summer RTI instructors.</p> <p>The supervisor will conduct pre-program training and provide ongoing</p>
---	--

Location Code: Washington County (900)

Quantity: 1.00

Cost: \$124.00

Line Item Total: \$124.00

Account Number: 72210 - Support Services/Regular Instruction

Line Item Number: 204 - State Retirement

Optional Program Code:

Location Code: Washington County (900)

Quantity: 1.00

Cost: \$250.00

Line Item Total: \$250.00

Account Number: 72210 - Support Services/Regular Instruction

Line Item Number: 212 - Employer Medicare

Optional Program Code:

Location Code: Washington County (900)

Quantity: 1.00

Cost: \$30.00

Line Item Total: \$30.00

Session Timeout (Hide Timer) 00:29:58

support throughout the duration of the program. This support will ensure that students' individual needs are addressed and that proper documentation is collected to inform instruction for the upcoming school year.

1 RTI teacher Supervisor count at 1 FTE

RTI teacher Supervisor estimated State Retirement (12.5%) \$250.00

RTI teacher Supervisor wages at \$2,000 An RTI supervisor will be assigned to support pre-planning and training for all RTI educators participating in the summer program. Responsibilities will include reviewing the list of registered students and identifying their individual support needs to effectively communicate these to the assigned summer RTI instructors.

The supervisor will conduct pre-program training and provide ongoing support throughout the duration of the program. This support will ensure that students' individual needs are addressed and that proper documentation is collected to inform instruction for the upcoming school year.

1 RTI teacher Supervisor count at 1 FTE

RTI teacher Supervisor estimated Employer Medicare (1.45%) \$30

RTI teacher Supervisor wages at \$2,000 An RTI supervisor will be assigned to support pre-planning and training for all RTI educators participating in the summer program. Responsibilities will include reviewing the list of registered students and identifying their individual support needs to effectively communicate these to the assigned summer RTI instructors.

The supervisor will conduct pre-program training and provide ongoing support throughout the duration of the program. This support will ensure that students' individual needs are addressed and that proper documentation is collected to inform instruction for the upcoming school year.

1 RTI teacher Supervisor count at 1 FTE

Total for filtered Budget Details:	\$2,404.00
Total for all other Budget Details:	\$992,535.04
Total for all Budget Details:	\$994,939.04
Adjusted Allocation:	\$994,939.04
Remaining:	\$0.00

[Return](#)

[TN.gov Directory](#) | [Web Policies](#) | [Accessibility](#)
TN Department of Education | Andrew Johnson Tower | 710 James Robertson Parkway | Nashville, TN 37243 | (629) 395-4684 | ePlan.Help@tn.gov

Session Timeout
(Hide Timer)
00:29:58

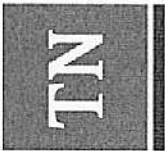

ePlan Home
Search
Reports
Inbox
Planning
Monitoring
Funding
Data and Information Requests
Project Summary
LEA Document Library
Address Book
TDOE Resources
Help for Current Page
Contact TDOE
ePlan Sign Out

Hale, Brad

Production
Session Timeout (Hide Timer)
00:29:59

Budget Detail

Washington County (900) Public District - FY 2026 - Summer Learning Camps - Rev 0 - Learning Camps

[Return](#)

Filtering - 4 out of 43 Budget Details match selected filters

Show All / Clear All

Account Number	Line Item Number	Location Code	Narrative
72410 - Office of the ...	All	All	No Options Selected

[Download Budget Data](#)

[Add Budget Detail](#)
[<< First](#)
[< Previous](#)
1
[Next >](#)
[Last >>](#)
 Items 1-4 out of 4

Delete Edit	Budget Detail
Account Number: 72410 - Office of the Principal Line Item Number: 104 - Principal(s) Optional Program Code: Location Code: Washington County (900) Quantity: 1.00 Cost: \$16,000.00 Line Item Total: \$16,000.00	Narrative Description <p>The estimated cost for two summer programs principal leaders wages for the Summer Learning Camp is \$16,000</p> <p>The camp will serve students in rising grades K-9 from all ten K-8 schools in the district and will take place at a centralized location. Their compensation will be based on their current daily pay rate, totaling an estimated \$14,350. These two leaders will be compensated \$33 per hour for 25 hours of pre-planning time and school safety summer plan with Leadership Team, amounting to \$1,650.</p> <p>Total wages at \$16,000</p> <p>2 Principals at 2 FTE</p>

Account Number: 72410 - Office of the Principal Line Item Number: 201 - Social Security Optional Program Code:	<p>Two Principal Leadership Social Security estimated at \$1,000 (6.2%)</p> <p>2 Principal count at 2FTE</p>
---	--

Location Code: Washington County (900)

Quantity: 1.00

Cost: \$1,000.00

Line Item Total: \$1,000.00

Account Number: 72410 - Office of the Principal

Line Item Number: 204 - State Retirement

Optional Program Code:

Location Code: Washington County (900)

Quantity: 1.00

Cost: \$2,000.00

Line Item Total: \$2,000.00

Account Number: 72410 - Office of the Principal

Line Item Number: 212 - Employer Medicare

Optional Program Code:

Location Code: Washington County (900)

Quantity: 1.00

Cost: \$240.00

Line Item Total: \$240.00

Session Timeout (Hide Timer) 00:29:59

Two Principal Leadership State Retirement estimated at \$2,000(12.5%)
2 Principal count at 2 FTE

Two Principal Leadership Employee Medicare estimated at \$240 (1.45%)
2 Principal count at 2FTE

Total for filtered Budget Details: \$19,240.00
Total for all other Budget Details: \$975,699.04
Total for all Budget Details: \$994,939.04
Adjusted Allocation: \$994,939.04
Remaining: \$0.00

[Return](#)

[TN.gov Directory](#) | [Web Policies](#) | [Accessibility](#)
TN Department of Education | Andrew Johnson Tower | 710 James Robertson Parkway | Nashville, TN 37243 | (629) 395-4684 | ePlan.Help@tn.gov

Session Timeout
(Hide Timer)
00:29:59

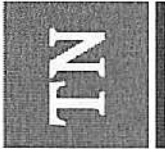

ePlan Home
Search
Reports
Inbox
Planning
Monitoring
Funding
Data and Information
Reimbursement
Requests
Project Summary
LEA Document Library
Address Book
TDOE Resources
Help for Current Page
Contact TDOE
ePlan Sign Out

Hale, Brad

Production
Session Timeout (Hide Timer)
00:29:59

Budget Detail

Washington County (900) Public District - FY 2026 - Summer Learning Camps - Rev 0 - Learning Camps

[Return](#)

Filtering - 7 out of 43 Budget Details match selected filters [Show All / Clear All](#)

Account Number: 72710 - Transportation All Location Code: All Narrative: No Options Selected

[Download Budget Data](#)

[Add Budget Detail](#) << First < Previous 1 Next > Last >> Items 1-7 out of 7 Items/Page: 10

Delete Edit Budget Detail

Account Number: 72710 - Transportation
 Line Item Number: 105 - Supervisor / Director
 Optional Program Code:
 Location Code: Washington County (900)

Quantity: 1.00

Cost: \$530.00

Line Item Total: \$530.00

Account Number: 72710 - Transportation

Line Item Number: 146 - Bus Drivers

Optional Program Code:

Pre-Planning Wages estimated at \$530
 Additional pre-planning support wages for after-hours assistance to ensure a smooth transition from regular school routes to summer program bus routes. This will include two transportation supervisor employees at \$33/hour for a total of 8 hours each. This support will include continuous communication with bus drivers and families to accommodate last-minute additions, route adjustments, and to provide families with clear, up-to-date route information. It will also ensure that families have access to timely assistance for any questions or concerns.

Wages for Bus Drivers estimated at \$52,640
 We estimate approximately 20 bus drivers will be utilized to support transportation for students to and from the summer program school site. Wages include their current daily rate for bus routes and additional summer program field trip transportation \$50,000. An additional \$33/hour will be allocated for group pre-planning meeting to review bus routes, procedures, and safety protocols. This estimate is approximately \$33/per hour x 4 hours of training x 20 bus drivers = \$52,640

Location Code: Washington County (900)

Quantity: 1.00

Cost: \$52,640.00

Line Item Total: \$52,640.00

Account Number: 72710 - Transportation

Line Item Number: 201 - Social Security

Optional Program Code:

Location Code: Washington County (900)

Quantity: 1.00

Cost: \$3,300.00

Line Item Total: \$3,300.00

Account Number: 72710 - Transportation

Line Item Number: 204 - State Retirement

Optional Program Code:

Location Code: Washington County (900)

Quantity: 1.00

Cost: \$6,500.00

Line Item Total: \$6,500.00

Account Number: 72710 - Transportation

Line Item Number: 212 - Employer Medicare

Optional Program Code:

Session Timeout (Hide Timer) 00:29:59

Social Security cost for Bus Drivers estimated at \$3,300 (6.2%)
We estimate approximately 20 bus drivers will be utilized to support transportation for student to and from the summer program school site. Wages include their current daily rate and additional summer program field trip transportation.
20 Bus Driver Count at 20 FTE

State Retirement cost for Bus Drivers estimated at \$6,500 (12.5%)
We estimate approximately 20 bus drivers will be utilized to support transportation for student to and from the summer program school site. Wages include their current daily rate and additional summer program field trip transportation.
20 Bus Driver Count at 20 FTE

Employee Medicare cost for Bus Drivers estimated at \$770 (1.45%)
We estimate approximately 20 bus drivers will be utilized to support transportation for student to and from the summer program school site. Wages include their current daily rate and additional summer program field trip transportation.
20 Bus Driver Count at 20 FTE

Location Code: Washington County (900)

Quantity: 1.00

Cost: \$770.00

Line Item Total: \$770.00

Account Number: 72110 - Transportation

Line Item Number: 338 - Maintenance & Repair Services - Vehicles

Optional Program Code:

Location Code: Washington County (900)

Quantity: 1.00

Cost: \$50,000.00

Line Item Total: \$50,000.00

Account Number: 72110 - Transportation

Line Item Number: 412 - Diesel Fuel

Optional Program Code:

Location Code: Washington County (900)

Quantity: 1.00

Cost: \$35,000.00

Line Item Total: \$35,000.00

Session Timeout (Hide Timer) 00:29:59

Maintenance and repair services are provided to address wear and tear resulting from summer programs, ensuring facilities are adequately prepared and maintained.

Additional diesel funds allocated for summer transportation will support both home-to-program site travel and daytime transportation for off-site field trips that enrich daily instructional activities. Approximately 20 bus drivers will provide transportation throughout the summer day, ensuring students are shuttled to and from home as well as to various educational field trip destination. Based on previous allocations, an estimated 20 buses will be used, with fuel costs averaging \$1,900 per bus for the duration of the summer program.

Total for filtered Budget Details:	\$148,740.00
Total for all other Budget Details:	\$846,199.04
Total for all Budget Details:	\$994,939.04
Adjusted Allocation:	\$994,939.04
Remaining:	\$0.00

[Return](#)

[TN.gov Directory](#) | [Web Policies](#) | [Accessibility](#)
TN Department of Education | Andrew Johnson Tower | 710 James Robertson Parkway | Nashville, TN 37243 | (629) 395-4684 | ePlan.Help@tn.gov

Session Timeout
(Hide Timer)
00:29:59

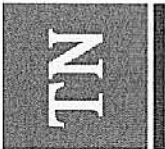

ePlan Home
Search
Reports
Inbox
Planning
Monitoring
Funding
Data and Information
Reimbursement Requests
Project Summary
LEA Document Library
Address Book
TDOE Resources
Help for Current Page
Contact TDOE
ePlan Sign Out

Hale, Brad

Production
Session Timeout (Hide Timer)
00:29:59

Budget Detail

Washington County (900) Public District - FY 2026 - Summer Learning Camps - Rev 0 - Learning Camps

[Return](#)

Filtering - 4 out of 43 Budget Details match selected filters

[Show All / Clear All](#)

Account Number	Line Item Number	Location Code	Narrative
73100 - Food Service	All	All	No Options Selected

[Download Budget Data](#)

[Add Budget Detail](#)
[Delete](#)
[Edit](#)
[Budget Detail](#)

<< First < Previous **1** Next > Last >> Items 1-4 out of 4 Items/Page: **10**

Account Number: 73100 - Food Service
Line Item Number: 165 - Cafeteria Personnel
Optional Program Code:
Location Code: Washington County (900)
Quantity: 1.00
Cost: \$55,000.00
Line Item Total: \$55,000.00
Account Number: 73100 - Food Service
Line Item Number: 201 - Social Security
Optional Program Code:

Wages for Food Service Employees estimated at \$55,000 Food service employees will be providing breakfast and lunch to our students attending summer programs. The pay rate for approximately 18 full-time workers will be determined based on their current daily salary rates.

18 Cafeteria Personnel at 18 FTE

Food Service Employees social security estimated at \$3,410 (6.2%) Food service employees will be providing breakfast and lunch to our students attending summer programs. Estimated social security cost \$3,410

18 Cafeteria Personnel at 18 FTE

Location Code: Washington County (900)

Quantity: 1.00

Cost: \$3,410.00

Line Item Total: \$3,410.00

Account Number: 73100 - Food Service

Line Item Number: 204 - State Retirement

Optional Program Code:

Location Code: Washington County (900)

Quantity: 1.00

Cost: \$6,875.00

Line Item Total: \$6,875.00

Account Number: 73100 - Food Service

Line Item Number: 212 - Employer Medicare

Optional Program Code:

Location Code: Washington County (900)

Quantity: 1.00

Cost: \$800.00

Line Item Total: \$800.00

Session Timeout (Hide Timer) 00:29:59

Food Service Employees state retirement estimated at \$6,875 (12.5%) Food service employees will be providing breakfast and lunch to our students attending summer programs.
Estimated state retirement cost \$6,875
18 Cafeteria Personnel at 18 FTE

Food Service Employees state retirement estimated at \$800 (1.45%) Food service employees will be providing breakfast and lunch to our students attending summer programs. Estimated state retirement cost \$800.
18 Cafeteria Personnel at 18 FTE

Total for filtered Budget Details: \$66,085.00
Total for all other Budget Details: \$928,854.04
Total for all Budget Details: \$994,939.04
Adjusted Allocation: \$994,939.04
Remaining: \$0.00

[Return](#)

[TN.gov Directory](#) | [Web Policies](#) | [Accessibility](#)
TN Department of Education | Andrew Johnson Tower | 710 James Robertson Parkway | Nashville, TN 37243 | (629) 395-4684 | ePlan.Help@tn.gov

Session Timeout
(Hide Timer)
00:29:59

<i>REQ DATE</i>
05/01/2026

Washington County Schools Nutrition

405 West College Street
 Jonesborough, TN 37659
 423-753-1107
 nutrition@wcde.org

<i>REQUISITION NUMBER</i>
1430260309

VENDOR KEY : GORDON F000
 SHIP DATE : 05/01/2026
 FISCAL YEAR : 2025-2026
 ENTERED BY : HARTGCHL000

PRINTED 05/07/2026

VENDOR:
 GORDON FOOD SERVICE
 PO Box 88029
 CHICAGO, IL 60680-1029

SHIP TO:
 Washington County Schools - Food Service
 405 W COLLEGE ST
 JONESBOROUGH, TN 37659

ATTN: CHLOE HARTGROVE

QUANTITY	UNIT	DESCRIPTION OF ITEMS OR MATERIALS	UNIT PRICE	AMOUNT
1		ADD ON GORDONS NON FOOD	90000.00000	90,000.00
		ACCOUNT SUMMARY (FOR INTERNAL USE)		
		ACCOUNT NUMBER	ACCOUNT AMOUNT	
		143 E 73100 421 000 00000 000	90,000.00	
			PAGE TOTAL	90,000.00
			TOTAL	90,000.00

This is a Requisition and not an official Purchase Order.
 The District is not financially responsible for the
 unauthorized purchases made with a Requisition.

<i>REQ DATE</i>
05/01/2026

Washington County Schools Nutrition

405 West College Street
 Jonesborough, TN 37659
 423-753-1107
 nutrition@wcde.org

<i>REQUISITION NUMBER</i>
1430260310

VENDOR KEY : GORDON F000
 SHIP DATE : 05/01/2026
 FISCAL YEAR : 2025-2026
 ENTERED BY : HARTGCHL000

PRINTED 05/07/2026

VENDOR:
 GORDON FOOD SERVICE
 PO Box 88029
 CHICAGO, IL 60680-1029

SHIP TO:
 Washington County Schools - Food Service
 405 W COLLEGE ST
 JONESBOROUGH, TN 37659

ATTN: CHLOE HARTGROVE

QUANTITY	UNIT	DESCRIPTION OF ITEMS OR MATERIALS	UNIT PRICE	AMOUNT
1		ADD ON GORDONS FOOD	200000.00000	200,000.00
		ACCOUNT SUMMARY (FOR INTERNAL USE)		
		ACCOUNT NUMBER	ACCOUNT AMOUNT	
		143 E 73100 422 000 00000 000	200,000.00	
			PAGE TOTAL	200,000.00
			TOTAL	200,000.00

This is a Requisition and not an official Purchase Order.
 The District is not financially responsible for the
 unauthorized purchases made with a Requisition.

PURCHASING DEPARTMENT

WASHINGTON COUNTY BOARD OF EDUCATION

PURCHASE ORDER

Purchase Order No 7924

Date Issued 5/1/26

Appropriation No.

Dept. Academics

School District Summer Programs

TO Benchmark Education
145 Huguenot St. 8th floor
New Rochelle, NY 10801

NOTICE TO VENDOR

1. Purchase order MUST bear two signatures in order to be valid.
2. Purchase order number MUST appear on all invoices submitted for payment.
3. Mail TWO copies of your invoice promptly to:

Washington County Board of Education
405 West College Street
Jonesborough, TN 37659
Telephone (423) 753-1105

Deliver to Cindy Hayes
Address 306 1/2 Forest DR.
Via Jonesborough, TN 37659

Articles on this order must be charged to account of

ARTICLES OR SERVICES	CODE	QUANTITY & UNIT	UNIT PRICE	TOTAL
(Unless otherwise stated all prices F.O.B. Destination) Steps to Advance Student Consumables & Digital See Quote 95604				
GRAND TOTAL - INCLUDING ALL ATTACHED PAGES				43,173.42

SUBJECT TO THE FOLLOWING CONDITIONS

1. All packages, cartons or other containers must be plainly marked with the purchase order number.
2. The right is reserved to purchase in the open market and to charge the difference to the Vendor in the event that deliveries are not made at the time specified in the bid and on this order.
3. Whenever a delivery is rejected, the Vendor shall be notified and be given the reason for the rejection. All rejected deliveries shall be held at the Vendor's risk and he shall bear the expense of removal.
4. Acceptance of this order includes acceptance of all terms, prices, delivery, instructions, specifications and conditions stated.
5. The county is not liable for Federal excise tax or state sales tax.
6. Each shipment and/or each purchase order should be covered by separate invoice.

IMPORTANT: INVOICES AND PACKAGES MUST BEAR PURCHASE ORDER NUMBER

VENDOR'S COPY

There is an otherwise unincumbered balance to the credit of the proper appropriation, allotment or fund to meet the expenditure covered by this purchase.

Authorized Signature

APPROVED:

Purchasing Agent



**BENCHMARK
EDUCATION
COMPANY**
145 Huguenot Street, 8th Floor
New Rochelle, New York 10801

Contact representative
E02081 Angie Templeton
Email: atempleton@benchmarkeducation.com
Office Phone:
Phone: 615-679-8020

QUOTE: 95604

Customer:

Sabrina St. John, Special Education Coordinator
Washington County Schools Board of Education
2002 Indian Ridge Road
Johnson City TN 37602
United States

Ship To:

Attn: Melinda Carr, Supervisor of Instruction
Washington County School Warehouse
145 1/2 Forest Drive
Jonesborough TN 37659

Product Code	Title	Price Level	Unit Price	Qty	Total Price
X88266R	Steps to Advance Literacy Solutions Gr. 2 Teacher Package Digital Renewal	1-Year	\$74.00	1	\$74.00
Price Adjustment	Prorated 15 month renewal to span 4/30/2026 - 7/31/2027				\$18.50
X88269R	Steps to Advance Literacy Solutions Gr. 5 Teacher Package Digital Renewal	1-Year	\$74.00	1	\$74.00
Price Adjustment	Prorated 15 month renewal to span 4/30/2026 - 7/31/2027				\$18.50
X88267R	Steps to Advance Literacy Solutions Gr. 3 Teacher Package Digital Renewal	1-Year	\$74.00	12	\$888.00
X88268R	Steps to Advance Literacy Solutions Gr. 4 Teacher Package Digital Renewal	1-Year	\$74.00	12	\$888.00
X88269R	Steps to Advance Literacy Solutions Gr. 5 Teacher Package Digital Renewal	1-Year	\$74.00	11	\$814.00
X88261R	Steps to Advance Literacy Solutions Gr. 2 Student Package Digital Renewal	1-Year	\$6.30	20	\$126.00
X88262R	Steps to Advance Literacy Solutions Gr. 3 Student Package Digital Renewal	1-Year	\$6.30	85	\$535.50
X88263R	Steps to Advance Literacy Solutions Gr. 5 Teacher Package Digital Renewal	1-Year	\$74.00	85	\$6,290.00
X88264R	Steps to Advance Literacy Solutions Gr. 5 Student Package Digital Renewal	1-Year	\$6.30	110	\$693.00
X88269R	Steps to Advance Literacy Solutions Gr. 5 Teacher Package Digital Renewal	1-Year	\$74.00	2	\$148.00
Price Adjustment	Prorated 11 month renewal to span 8/31/2026 - 7/31/2027				(\$12.33)
X88262R	Steps to Advance Literacy Solutions Gr. 3 Student Package Digital Renewal	1-Year	\$6.30	50	\$315.00
Price Adjustment	Prorated 11 month renewal to span 8/31/2026 - 7/31/2027				(\$26.25)
X88263R	Steps to Advance Literacy Solutions Gr. 4 Student Package Digital Renewal	1-Year	\$6.30	50	\$315.00



**BENCHMARK
EDUCATION
COMPANY**
145 Huguenot Street, 8th Floor
New Rochelle, New York 10801

Contact representative
E02081 Angie Templeton
Email: atempleton@benchmarkeducation.com
Office Phone:
Phone: 615-679-8020

QUOTE: 95604

Product Code	Title	Price Level	Unit Price	Qty	Total Price
Price Adjustment	Prorated 11 month renewal to span 8/31/2026 - 7/31/2027				(\$26.25)
X88264R	Steps to Advance Literacy Solutions Gr. 5 Student Package Digital Renewal	1-Year	\$6.30	50	\$315.00
Price Adjustment	Prorated 11 month renewal to span 8/31/2026 - 7/31/2027				(\$26.25)
Y65060	BEC Steps to Advance Literacy Solutions Gr. 2 Student Books 5-Copy Set 1-Year	Current	\$315.00	4	\$1,260.00
Y65061	BEC Steps to Advance Literacy Solutions Gr. 3 Student Books 5-Copy Set 1-Year	Current	\$315.00	27	\$8,505.00
Y65062	BEC Steps to Advance Literacy Solutions Gr. 4 Student Books 5-Copy Set 1-Year	Current	\$315.00	27	\$8,505.00
Y65063	BEC Steps to Advance Literacy Solutions Gr. 5 Student Books 5-Copy Set 1-Year	Current	\$315.00	32	\$10,080.00

Subtotal	Discount / Gratis Product Total	Sales Tax	Shipping Cost	Total
\$39,771.42	\$0.00	\$0.00	\$3,402.00	\$43,173.42 USD

Memo
Prorated Renewal Estimate: Subscriptions to expire 7/31/2027 / A temporary 2% fuel surcharge has been added to our standard 10% Shipping and Handling charges.

- * The above pricing cannot be combined with any other offers.
- * Price valid through 6/13/2026. Price quote must be attached to school purchase orders to receive the quoted price.
- * All digital subscriptions will end on July 31st the last year of the term purchased.
- * Any changes, including cancellations to the originally agreed upon PD trainings, must be made at least 10 business days prior to the delivery of the PD trainings. Customized PD changes must be submitted at least 15 business days prior to agreed delivery date and must go through the customized request process. Benchmark Education will do its best to accommodate the requested changes; however, it reserves the right to render services according to the initial agreement. Please note that any changes requested may incur an additional charge or reduction of number of PD training days rendered. Please note that no changes can be requested on site and all requests must go through the Company approval process.



**BENCHMARK
EDUCATION
COMPANY**
145 Huguenot Street, 8th Floor
New Rochelle, New York 10801

Contact representative
E02081 Angie Templeton
Email: atempleton@benchmarkeducation.com
Office Phone:
Phone: 615-679-8020

QUOTE: 95604

PLEASE INCLUDE THIS PROPOSAL WITH YOUR PURCHASE ORDER ALONG WITH THE FOLLOWING INFORMATION

- Billing Contact Name _____
- Billing Contact Email _____
- Billing Contact Phone _____

PLEASE INCLUDE THE FOLLOWING INFORMATION FOR ALL DIGITAL SUBSCRIPTIONS

- Name of School(s) That Will Use the Subscription(s)
Attach separate document if necessary _____

- Onboarding Tech Contact Name _____
- Onboarding Tech Contact E-Mail _____

• REQUIRED

SEND ORDER TO: Benchmark Education Company
6295 Commerce Center Drive, Suite B| Groveport, OH 43125-1160
Email: neworders@benchmarkeducation.com
Phone: 877-236-2465| Fax: 877-732-8273

Terms of Service

* By placing an order for Benchmark Education Company ("BEC") products (the "Products"), the entity ("Customer") that this proposal has been prepared for agrees to be bound by BEC's Terms of Service and Terms of Use and Privacy Policy (Please visit this site: <https://help.benchmarkuniverse.com/bubateacher/Content/Customer%20Support/Privacy%20Policy.htm?Highlight=privacy>). Subject to the Customer's payment of the fees set out above, BEC grants to Customer a non-exclusive and non-transferable license to access and use the Products under the terms described in this Terms of Service. The proposal contains the scope of use allowed and the term of Customer's license to the Products.

WCS-RFP Review-Beverage Vendors-April 2026		
Specifications	PepsiCo	Coca-Cola
1. Provide detailed schedule for updating and maintaining product logos for all scoreboards;	YES	YES
2. Provide \$ _____ sponsorship per year;	\$5,000	\$14,540
3. Provide \$ _____ for scholarships per year;	\$2,500	\$1,000
4. Provide \$ _____ for scoreboard purchases per year;	\$2,500	\$0
5. Pay rebate of \$ _____ per case on purchases through concessions;	\$2.00-24 pack; \$1.00 per 12-pack	\$2.00
6. Provide the commission rates for sold items;	20%	25%
7. Provide a minimum number of drink machines in each school, based on student enrollment, with at least one machine per 200 students;	YES	YES
8. Provide detailed schedule for servicing drink/vending machines at all WCS buildings;	YES	YES
9. Provide _____ complimentary cases of products per year for Central Office Board Meetings;	150	100
10. Any other services vendor may opt to provide. (SEE BELOW)		
10. PepsiCo: Above items #s 2,3, and 4 \$ amounts are subject to a minimum 4500 cases, if that amount is not met, the payables will decrease; 6 large Gatorade kits per year; Vending machine rates: 20 oz water= \$2.25, 20 oz Soda=\$2.50, 20 oz Gatorade=\$3.00		
10. Coca-Cola: \$1000 first year for large Powerade kits. \$500 in year three; "Sideline" program for more free Powerade kits dependent upon purchases of Powerade cases; Vending machine rates: 20 oz water= \$2.50, 20 oz Soda=\$3.00, 20 oz Powerade=\$3.00; \$350 minimum purchase for free delivery for concession stands		



WASHINGTON COUNTY SCHOOLS

INSPIRE ★ STRIVE ★ THRIVE

Mr. Jerry S. Boyd
Superintendent

405 W. College St.
Jonesborough, TN 37659
Phone (423) 753-1100

By submitting this bid, the bidder agrees that the quoted products and services meet the stated specifications and will remain in compliance with Washington County Board of Education standards throughout the contract period.

Bidder Information:

Printed Name: Kenny Turner

Signature: [Handwritten Signature]

Telephone #: 423-929-8453

Cell #: 423-612-3386

Fax #: _____

Company Name: Shelton Tile + Flooring

Mailing Address: 1308 E. Main St.

City/State/ZIP: Johnson City TN 37601

Date: April 21, 2026

Email Address: Kenny.Sheltontile@gmail.com

Exceptions (If none, state "No conditions and/or exceptions.")

Does not include covebase or bullnose
but can be added.

Eric Barnes
Annette Buchanan
Keith Ervin

Board of Directors

Chad Fleenor
David Hammond
Gregg Huddleston

Mike Masters
Whitney Riddle
Vince Walters



WASHINGTON
COUNTY SCHOOLS
INSPIRE ★ STRIVE ★ THRIVE

Mr. Jerry S. Boyd
Superintendent

405 W. College St.
Jonesborough, TN 37659
Phone (423) 753-1100

Terms and Conditions

- **Bid Validity:** All bids must be valid for a minimum of 60 days from the submission deadline.
- **Selection Criteria:** Bids will be evaluated based on price, material quality, contractor experience and reputation, warranty terms, and the completeness of the proposal.
- **Site Visit:** All bidders are encouraged to visit each site location. A time may be scheduled with WCS Maintenance Director Jeremy Moore who can be reached at 423-753-1129 or moorej4@wcde.org

Submission Instructions

Bids must be received no later than the deadline specified above. Submissions should be delivered to Dr. Jarrod Adams 405 W. College St. Jonesborough, TN 37659 in a **sealed envelope** with the subject line "Bid for Kitchen Flooring".

TOTAL BID AMOUNT: \$ _____

20,972.01

Board of Directors

Eric Barnes
Annette Buchanan
Keith Ervin

Chad Fleenor
David Hammond
Gregg Huddleston

Mike Masters
Whitney Riddle
Vince Walters

Shelton Tile and Flooring

1308 E Main St
 Johnson City, TN 37601
 (423)929-8453
 www.sheltontileandflooring.com



Estimate

ADDRESS

Sulphur Springs Elementary School
 Washington County Schools
 1518 Gray Station
 Jonesborough, TN 37659

ESTIMATE 2591
 DATE 04/21/2026

	DESCRIPTION	QTY	RATE	AMOUNT
	This estimate includes work for the kitchen area and the kitchen bathroom only. It does not include any office spaces. Cove base is not included in this estimate; however, it can be added and priced separately upon request.			
	If you have any questions or need further clarification, please feel free to reach out at Kenny.sheltontile@gmail.com			
Quarry Textures Ashen Gray 6x6	11sf/box	1,089	4.70	5,118.30T
TEC Power Grout - 25 lb. - color TBD		20	89.90	1,798.00T
Dumpster Rental	For Disposal of Tear Out and Scrap Material	1	300.00	300.00T
dump fee		1	100.00	100.00T
Labor- Demo	includes tool rental if needed	985	4.00	3,940.00
Install		985	7.00	6,895.00
Freight		1	199.00	199.00T
[SP] MICROBIAL ACRYLIC ADHESIVE REMOVER 4 GALLON		1	399.99	399.99T
Misc	estimate for transitions and other misc. materials	1	200.00	200.00T
[SP] All Set Thin Set White 50 lbs		25	39.99	999.75T
1/8" Ultimate "X" Leave In Spacer 700 Pc Jar		10	14.25	142.50T

NOTES:	SUBTOTAL	20,092.54
[SP] Special Order items are non-returnable. Schluter products are non-returnable.	TAX	879.47

If the estimate is acceptable and you would like to place an order please confirm by phone or email

TOTAL

\$20,972.01

Shelton Tile and Flooring is not responsible for square footage ordered.

We recommend the installer of the customer's project to figure quantities.

Due to current supply volatility all ETAs are merely estimates and subject to change

50% deposit required to order material.

Balance due upon arrival of material to Shelton Tile & Flooring

Effective July 1st 2021, if using a credit/debit card rather than cash or check a 3% convenience fee will apply to the total invoice before tax.

For delivery 1 week prior notice is required.

Accepted By

Accepted Date



WASHINGTON COUNTY SCHOOLS

INSPIRE ★ STRIVE ★ THRIVE

Mr. Jerry S. Boyd
Superintendent

405 W. College St.
Jonesborough, TN 37659
Phone (423) 753-1100

By submitting this bid, the bidder agrees that the quoted products and services meet the stated specifications and will remain in compliance with Washington County Board of Education standards throughout the contract period.

Bidder Information:

Printed Name: Kenny Turner

Signature: [Handwritten Signature]

Telephone #: 423-929-8453

Cell #: 423-612-3386

Fax #: _____

Company Name: Shelton Tile + Flooring

Mailing Address: 1308 E. Main St.

City/State/ZIP: Johnson City TN 37601

Date: April 21, 2026

Email Address: Kenny.Sheltontile@gmail.com

Exceptions (If none, state "No conditions and/or exceptions.")

Does not include Covebase or bullnose
but can be added.

Board of Directors

Eric Barnes
Annette Buchanan
Keith Ervin

Chad Fleenor
David Hammond
Gregg Huddleston

Mike Masters
Whitney Riddle
Vince Walters



WASHINGTON
COUNTY SCHOOLS
INSPIRE ★ STRIVE ★ THRIVE

Mr. Jerry S. Boyd
Superintendent

405 W. College St.
Jonesborough, TN 37659
Phone (423) 753-1100

Terms and Conditions

- **Bid Validity:** All bids must be valid for a minimum of 60 days from the submission deadline.
- **Selection Criteria:** Bids will be evaluated based on price, material quality, contractor experience and reputation, warranty terms, and the completeness of the proposal.
- **Site Visit:** All bidders are encouraged to visit each site location. A time may be scheduled with WCS Maintenance Director Jeremy Moore who can be reached at 423-753-1129 or moorej4@wcde.org

Submission Instructions

Bids must be received no later than the deadline specified above. Submissions should be delivered to Dr. Jarrod Adams 405 W. College St. Jonesborough, TN 37659 in a **sealed envelope** with the subject line "Bid for Kitchen Flooring".

TOTAL BID AMOUNT: \$ _____

21,940.90

Board of Directors

Eric Barnes
Annette Buchanan
Keith Ervin

Chad Fleenor
David Hammond
Gregg Huddleston

Mike Masters
Whitney Riddle
Vince Walters

Shelton Tile and Flooring

1308 E Main St
 Johnson City, TN 37601
 (423)929-8453
 www.sheltontileandflooring.com



Estimate

ADDRESS
 West View Elementary School
 Washington County School
 2847 Old State Rte 34
 Limestone, TN 37681

ESTIMATE 2592
 DATE 04/21/2026

DESCRIPTION	QTY	RATE	AMOUNT
This estimate includes work for the kitchen area and office space. It does not include the kitchen bathroom. Cove base is not included in this estimate; however, it can be added and priced separately upon request. If you have any questions or need further clarification, please feel free to reach out at Kenny.sheltontile@gmail.com			
Quarry Textures Ashen Gray 6x6	1,144	4.70	5,376.80T
TEC Power Grout - 25 lb. - color TBD	21	89.90	1,887.90T
Dumpster Rental	1	300.00	300.00T
dump fee	1	100.00	100.00T
Labor- Demo	1,033	4.00	4,132.00
Install	1,033	7.00	7,231.00
Freight	1	199.00	199.00T
[SP] MICROBIAL ACRYLIC ADHESIVE REMOVER 4 GALLON	1	399.99	399.99T
Misc	1	200.00	200.00T
[SP] All Set Thin Set White 50 lbs	26	39.99	1,039.74T
1/8" Ultimate "X" Leave In Spacer 700 Pc Jar	11	14.25	156.75T

NOTES:	SUBTOTAL	21,023.18
[SP] Special Order items are non-returnable. Schluter products are non-returnable.	TAX	917.72

If the estimate is acceptable and you would like to place an order please confirm by phone or email

TOTAL

\$21,940.90

Shelton Tile and Flooring is not responsible for square footage ordered.

We recommend the installer of the customer's project to figure quantities.

Due to current supply volatility all ETAs are merely estimates and subject to change

50% deposit required to order material.

Balance due upon arrival of material to Shelton Tile & Flooring

Effective July 1st 2021, if using a credit/debit card rather than cash or check a 3% convenience fee will apply to the total invoice before tax.

For delivery 1 week prior notice is required.

Accepted By

Accepted Date



WASHINGTON
COUNTY SCHOOLS
INSPIRE * STRIVE * THRIVE

Mr. Jerry S. Boyd
Superintendent

405 W. College St.
Jonesborough, TN 37659
Phone (423) 753-1100

By submitting this bid, the bidder agrees that the quoted products and services meet the stated specifications and will remain in compliance with Washington County Board of Education standards throughout the contract period.

Bidder Information:

Printed Name: Steve Garrison

Signature: [Handwritten Signature]

Telephone #: 423-791-2799

Cell #: _____

Fax #: _____

Company Name: ES Dockery, Inc

Mailing Address: 254 Christian Church Rd

City/State/ZIP: Gray, TN 37615

Date: 4-21-26

Email Address: stevegarrison@esdockery.com

Exceptions (If none, state "No conditions and/or exceptions.")

Removal and replacement of fixtures by owner

Door cut offs by owner

Removal of existing VCT and adhesives by others

Includes vinyl base at Sulpher Springs; no base at West View

Board of Directors

Eric Barnes
Annette Buchanan
Keith Ervin

Chad Fleenor
David Hammond
Gregg Huddlestone

Mike Masters
Whitney Riddle
Vince Walters



WASHINGTON
COUNTY SCHOOLS

INSPIRE ★ STRIVE ★ THRIVE

Mr. Jerry S. Boyd
Superintendent

405 W. College St.
Jonesborough, TN 37659
Phone (423) 753-1100

Terms and Conditions

- **Bid Validity:** All bids must be valid for a minimum of 60 days from the submission deadline.
- **Selection Criteria:** Bids will be evaluated based on price, material quality, contractor experience and reputation, warranty terms, and the completeness of the proposal.
- **Site Visit:** All bidders are encouraged to visit each site location. A time may be scheduled with WCS Maintenance Director Jeremy Moore who can be reached at 423-753-1129 or moorej4@wcde.org

Submission Instructions

Bids must be received no later than the deadline specified above. Submissions should be delivered to Dr. Jarrod Adams 405 W. College St. Jonesborough, TN 37659 in a **sealed envelope** with the subject line "Bid for Kitchen Flooring".

TOTAL BID AMOUNT: \$45,195.00

Board of Directors

Eric Barnes
Annette Buchanan
Keith Ervin

Chad Fleenor
David Hammond
Gregg Huddleston

Mike Masters
Whitney Riddle
Vince Walters



STATE OF TENNESSEE
DEPARTMENT OF
COMMERCE AND INSURANCE



E. S. DOCKERY, INC.

424610

ID NUMBER: 30879
LIC STATUS: ACTIVE
EXPIRATION DATE: January 31, 2027

BOARD FOR LICENSING CONTRACTORS
CONTRACTOR

THIS IS TO CERTIFY THAT ALL REQUIREMENTS
OF THE STATE OF TENNESSEE HAVE BEEN MET

E. S. DOCKERY, INC.
254 CHRISTIAN CHURCH ROAD
GRAY, TN 37615

State of Tennessee

424610

BOARD FOR LICENSING CONTRACTORS
CONTRACTOR
E. S. DOCKERY, INC.

This is to certify that all requirements of the State of Tennessee have been met.

ID NUMBER: 30879
LIC STATUS: ACTIVE
EXPIRATION DATE: January 31, 2027
\$750,000.00; BC-b(sm)



IN-1313
DEPARTMENT OF
COMMERCE AND INSURANCE



STATE OF TENNESSEE
DEPARTMENT OF REVENUE

Business Tax Filing Status Certificate

February 19, 2026

E. S. DOCKERY, INC.
254 CHRISTIAN CHURCH RD
JOHNSON CITY TN 37615-4475

Letter ID: L0129340864
Account ID: 1000945302-BUS
Account Type: Business Tax

Dear E. S. DOCKERY, INC.:

This certificate confirms the business tax filing status of Retailer for the above-named taxpayer. The certificate is valid beginning April 15, 2026 and expiring on April 15, 2027 for the following location:

Location ID: 1001494523
Location Address: E. S. DOCKERY, INC.
254 CHRISTIAN CHURCH RD
GRAY TN 37615-4475

According to Tenn. Code Ann. § 67-4-720, a vendor that receives a certificate from a customer shall not owe additional tax, nor be refunded tax, based on a retroactive change in the customer's filing status as a wholesaler or retailer during the certificate's effective period.

The taxpayer may furnish its supplier(s) with a **COPY** of the enclosed certificate upon vendor(s) request. Vendors may rely on the certificate for transactions occurring during the certificate's effective period for the purpose of determining their business liability. The original certificate should be retained **for the taxpayer's records**. The vendor must maintain a file copy as evidence of their business tax filings.

Tennessee Department of Revenue

Business Tax Filing Status Certificate

Location Address:
E. S. DOCKERY, INC.
254 CHRISTIAN CHURCH RD
GRAY TN 37615-4475

Effective Period Begin: April 15, 2026
Effective Period End: April 15, 2027
Filing Status: Retailer
Location ID: 1001494523

AMERICAN OLEAN 1-YEAR LIMITED WARRANTY

American Olean Corporation warrants that manufactured products will be free from defect for a period of one-year from date of purchase. Defect is defined as a shortfall in the product to perform to American Olean specifications as disclosed in product literature, within industry allowable tolerances as set forth in standard, national industry protocols. American Olean provides detailed information in its product literature regarding appropriate tile and stone applications. Failure to comply with recommended applications voids this warranty. **THIS ONE-YEAR EXPRESS WARRANTY IS THE SOLE WARRANTY EXTENDED AND REPLACES ANY STATUTORY WARRANTIES TO THE MAXIMUM EXTENT ALLOWABLE BY LAW.**

Implied Warranty of Fitness for a Particular Purpose

American Olean provides detailed information in its product literature regarding appropriate tile and stone applications. Failure to comply with recommended applications voids this warranty. There are no warranties extended beyond the description on the face hereof.

Implied Warranties Limited in Duration and Scope

The Federal Magnuson-Moss Warranty Act limits disclaimers of implied warranties involving consumer products. To the maximum extent allowable by federal and state law, this warranty supplements or supersedes federal and state consumer goods warranty protections. There are no warranties extended beyond the description on the face hereof.

Additional Exclusions

All warranty claims must be reported immediately. Failure to report any warranty claim within 30 days of defect discovery will void this warranty. All products must be inspected prior to installation. Installation of products with visual defects or nonconformities apparent prior to installation voids this warranty.

Customer misuse including negligence, physical, or chemical abuse is not covered by this warranty. Installation defects are not covered by this warranty.

Tile is subject to variation in technical specifications, including DCOF, due to inherent variability in the raw materials and production process. Express technical specifications are not guarantees of minimum or maximum thresholds of performance. Tile containing abrasives create a rough surface, creating cleaning challenges because dirt and other contaminants lodge in the surface. Extra attention is necessary to assure contaminants are removed promptly. Unless specifically stated otherwise, tile recommended for floor or wall applications refers to interior applications only. American Olean does not recommend its products for use on ceilings or roofs, unless specifically disclosed as being suitable for ceilings or roofs in product literature. Local building codes may dictate minimum tile performance specifications. American Olean does not warrant product installations that violate building codes.

Natural stone products are mined and cut from natural formations. Because these products are not subject to a manufacturing process, quality warranties are limited to the specified representations in product literature and guidelines established by the Marble Institute of America. American Olean does not warrant natural stone products for shade, size, thickness, warping, cleft variations, surface finish variations, or other natural variances on stone products.

Photographic color images may not be an exact product match. Product samples are representative only and may not be an exact match to supplied materials due to variations in batch manufacturing or naturally occurring stone. Supplied materials may have slight differences in color, shade, and/or surface appearance.

Remedy Limitation & Disclaimer

If a defect in materials or workmanship is discovered within the one-year period, American Olean will either refund the price of the product or provide a replacement product after a reasonable number of attempts to remedy product defects. Buyer's remedy is limited to replacement or repair of the defective product. No consequential (including, but not limited to, lost profits) or incidental damages are recoverable. American Olean disclaims all express warranties not contained in this limited express warranty.

No person has authority to make representations other than those in this writing. Any representations made in connection with the sale of this product that differs from the terms of this warranty are not valid and should be brought to the attention of American Olean immediately (1-888-AOT-TILE).

LEGAL NOTICE: WARNING -- Tile and installation products contain chemicals known to the state of California to cause cancer, birth defects, reproductive harm, respiratory harm or other health problems. For more product-specific information on chemical content, obtain an MSDS at Americanolean.com or contact American Olean at 1-888-AOT-TILE.

To Make A Claim:

1. The original purchaser must notify an American Olean Sales Service Center or an authorized representative in writing within 30 days of the discovery of any defect.
2. After notification, American Olean or an authorized representative will inspect and/or test the product for defect and complete a Product Claim Action form. No claim will be honored without product inspection by American Olean or an authorized representative.
3. Upon determination that the product defect claim is valid, American Olean will notify the purchaser in writing. American Olean reserves the right to repair, replace or refund the originally-purchased product, at its sole discretion.



WASHINGTON COUNTY SCHOOLS

INSPIRE ★ STRIVE ★ THRIVE

Mr. Jerry S. Boyd
Superintendent

405 W. College St.
Jonesborough, TN 37659
Phone (423) 753-1100

By submitting this bid, the bidder agrees that the quoted products and services meet the stated specifications and will remain in compliance with Washington County Board of Education standards throughout the contract period.

Bidder Information:

Printed Name: Keith Malone
Signature: *Keith Malone*
Telephone #: 423 282 1112
Cell #: 423 360 7729
Fax #: 423 282 1113
Company Name: K+M Flooring
Mailing Address: 3901 Bristol Hwy Ste 203
City/State/ZIP: Johnson City, TN 37601
Date: 4-16
Email Address: Kandmflooring3901@gmail.com

License # 0027383

Exceptions (If none, state "No conditions and/or exceptions.")

Floor Must Be Empty of Appliance
& Furn of Table. Ready to Start Prepwork
and Installation.

Board of Directors

Eric Barnes
Annette Buchanan
Keith Ervin

Chad Fleenor
David Hammond
Gregg Huddleston

Mike Masters
Whitney Riddle
Vince Walters



WASHINGTON COUNTY SCHOOLS

INSPIRE ★ STRIVE ★ THRIVE

Mr. Jerry S. Boyd
Superintendent

405 W. College St.
Jonesborough, TN 37659
Phone (423) 753-1100

Terms and Conditions

- Bid Validity: All bids must be valid for a minimum of 60 days from the submission deadline.
- Selection Criteria: Bids will be evaluated based on price, material quality, contractor experience and reputation, warranty terms, and the completeness of the proposal.
- Site Visit: All bidders are encouraged to visit each site location. A time may be scheduled with WCS Maintenance Director Jeremy Moore who can be reached at 423-753-1129 or moorej4@wcde.org

10:30

Submission Instructions

Bids must be received no later than the deadline specified above. Submissions should be delivered to Dr. Jarrod Adams 405 W. College St. Jonesborough, TN 37659 in a **sealed envelope** with the subject line "Bid for Kitchen Flooring".

Westview
Sulfur Springs

TOTAL BID AMOUNT: \$

Both 4/226.⁰⁰

Board of Directors

Eric Barnes
Annette Buchanan
Keith Ervin

Chad Fleenor
David Hammond
Gregg Huddlestone

Mike Masters
Whitney Riddle
Vince Walters

K&M Flooring, Inc.

3901 Bristol Hwy. Ste#203

Johnson City, TN 37601

Phone: 423-282-1112

Fax: 423-282-1113

EST

SOLD TO Washington Co School	SHIPPED TO West View	VIA
ADDRESS	ADDRESS	
CITY, STATE, ZIP	CITY, STATE, ZIP Janesborough Tn.	
CUSTOMER ORDER NO.	DATE 4-21-26	

1200#	Quarry Tile	ABRASIVE Surface Red EASOL Edge Tile	5.89	6948.00
	Prep the Floor			500.00
25	Thinset (Delta set)			1125.00
8	Grout Power Grout		120.00	960.00
2 boxes	Cove Base 4" BLACK			360.00
6	Cove Base Glue		15.00	90.00
3	Slender Bar			180.00
	Shipping			850.00
	labor to install			960.00
	* They Re Move all old Flooring & Appliance *		Total	20613.00
<p>Thanks Keith Malone</p>				

K&M Flooring, Inc.

3901 Bristol Hwy. Ste#203

Johnson City, TN 37601

Phone: 423-282-1112

Fax: 423-282-1113

EST

SOLD TO <u>Washington Co School</u>		SHIPPED TO <u>Sulfur Springs</u>	VIA
ADDRESS		ADDRESS	
CITY, STATE, ZIP		CITY, STATE, ZIP <u>Janesborough Tn.</u>	
CUSTOMER ORDER NO.	SOLD BY	TERMS	DATE <u>4-21-26</u>

1200ft	Quarry Tile	ABRASIVE Synthetic Red EASOL Edge Tile	5.89	6948.00
	Prep the Floor			500.00
25	Thinset (Delta set)			1125.00
8	Grout Power Grout		120.00	960.00
2 boxes	Cove Base 4" Black			360.00
6	Cove Base Glue		15.00	90.00
3	Slender Bar			180.00
	Shipping			850.00
	labor to install			9600.00
	* They Remove all old Flooring & Appliance *		Total	20613.00

Thanks Keith Malin



Safety Data Sheet

Quarry Tile, Chemical Brick, Thin Brick

Section 1. Identification

Product Identifier	Quarry Tile, Chemical Brick, Thin Brick		
Synonyms	N/A		
Manufacturer Stock Numbers	N/A		
Recommended use	Products are used as exterior and interior floor and wall coverings and finishes.		
Uses advised against	N/A		
Manufacturer Contact Address	Summitville Tiles, Inc PO BOX 73 Summitville , OHIO, 43962 USA		
	Phone	Emergency Phone	Fax
	(330) 223-1511	(330) 223-1511	(330) 223-1414
	Email contact@summitville.com		

Section 2. Hazards Identification

Classification	N/A
Signal Word	
Pictogram	
Hazard Statements	N/A
Precautionary Statements	
Response	N/A
Prevention	N/A
Storage	N/A
Disposal	N/A
Ingredients of unknown toxicity	0%

Hazards not Otherwise Classified

Additional Information

DO NOT DRY CUT THIS PRODUCT as dry cutting may release respirable silica and will release respirable dust. Use a wet saw for all cutting operations. This product is otherwise considered an article and is not hazardous under normal transportation, installation, and subsequent useage.

Section 3. Ingredients

CAS	Ingredient Name	Weight %
14808-60-7	Quartz (SiO2)	15% - 25%

Occupational exposure limits, if available, are listed in Section 8.

Section 4. First-Aid Measures

Inhalation If exposed to excessive levels of dusts, remove to particulate free environment and get medical attention if cough or other symptoms develop.

Section 5. Fire Fighting Measures

Suitable Extinguishing Media Material will not burn.

Unsuitable Extinguishing Media N/A

Section 6. Accidental Release Measures

Clean-Up This material is not hazardous under normal usage or clean up of debris. If pieces are broken, edges may be sharp. Use caution when picking up pieces that may be sharp. Sweep up small pieces in a manner that minimizes dust as dust may contain respirable silica.

Section 7. Handling and Storage

Storage Shelf life, unlimited.

Section 8. Exposure Controls/Personal Protection

Occupational Exposure Limits	Ingredient Name	ACGIH TLV	OSHA PEL	STEL
------------------------------	-----------------	-----------	----------	------

	Quartz (SiO2)	N/A	N/A	N/A
--	---------------	-----	-----	-----

Personal Protective Equipment Goggles, Gloves, Respirator

Other clothing

Cut resistant gloves may be necessary if handling broken shards that may have sharp edges. Gloves not normally needed during other operations. Respirator not needed unless dust is being created by incorrectly cutting the materials with a dry saw. Use a wet saw or water jet only to cut this product. Goggles needed when cutting this product or if "chipping" this product such as with a hammer.

Section 9. Physical and Chemical Properties

Physical State	Solid
Color	Solid tile or brick
Odor	none
Odor Threshold	N/A
Solubility	insoluble
Partition coefficient Water/n-octanol	N/A
VOC%	N/A
Viscosity	NA
Specific Gravity	1
Density lbs/Gal	N/A
Pounds per Cubic Foot	N/A
Flash Point	NA
FP Method	NA
Ph	NA
Melting Point	NA
Boiling Point	NA
Boiling Range	NA
LEL	N/A
UEL	N/A
Evaporation Rate	NA
Flammability	not flammable
Decomposition Temperature	NA
Auto-ignition Temperature	NA
Vapor Pressure	NA
Vapor Density	NA

Section 10. Stability and Reactivity

Conditions to avoid Avoid contact with Hydrofluoric acid.

Section 11. Toxicological Information

Inhalation Dust generated from dry cutting quarry tiles, thin bricks, and chemical bricks may release respirable and non-respirable crystalline silica. Crystalline silica is a known carcinogen and may lead to a condition known as silicosis in humans if proper precautions are not followed.

Eyes Eyes may be irritated by dust generated by dry cutting chemical bricks, quarry tiles, and/or thin bricks and during dry demolition. Protect eyes from potential injury from dust and/or broken chips when cutting or demolishing.

Section 12. Ecological Information

Not hazardous There is no evidence that these materials produce any environmental hazards.

Section 13. Disposal

Disposal should be in accordance with applicable regional, national and local laws and regulations. Not a hazardous waste per US EPA regulations.

Section 14. Transport Information

UN Number	N/A
UN Proper Shipping Name	N/A
DOT Classification	N/A
Packing Group	N/A
Additional Information	Quarry tile, chemical brick, thin brick products are not classified as hazardous for storage or transportation considerations.

Section 15. Regulatory Information

Silica	Dry cutting, chipping, breaking, abrading, drilling, and/or dry demolishing of these products releases dust that may contain crystalline silica. Use proper respiratory protection. Do not inhale dust.
--------	---

Section 16. Other Information

Revision Date

5/4/2015

While the information and recommendations in this publication are to the best of our knowledge, information and belief accurate at the date of publication, NOTHING HEREIN IS TO BE CONSTRUED AS A WARRANTY, EXPRESS OR OTHERWISE.

IN ALL CASES, IT IS THE RESPONSIBILITY OF THE USER TO DETERMINE THE APPLICABILITY OF SUCH INFORMATION AND RECOMMENDATIONS AND THE SUITABILITY OF ANY PRODUCT FOR ITS OWN PARTICULAR PURPOSE.



SPECIFICATIONS FOR
UNGLAZED QUARRY TILE
AND
UNGLAZED, OLDE TOWNE QUARRY TILE
December 3, 2021

1. Facial Dimensions – ASTM C-499-20

The average facial dimension(s) of each tile in the sample when measured as described in ASTM C-499-09 shall not vary more than +/- 2.0% from the nominal facial dimension(s). The range of facial dimensions of all tile in the sample shall not exceed +/-0.75% of the average facial dimension of the sample when measured according to ASTM C-499-20.

Above referenced products fall well within ANSI Specification A137.1-2021 for this property.

2. Warpage – ASTM C485-16

When measured as described in ASTM C-485-09, the warpage of each tile in the sample shall not exceed +/- 1.5% along any edge nor +/- 1.0% along either diagonal.

Above referenced products fall well within ANSI Specification A137.1 -2021 for this property.

3. Wedging – ASTM C502-16

Applicable to 6" x 6" and larger quarry tile. When measured as described in ASM C-50204, the wedging of each tile in the sample shall not exceed +/- 1.0%.

Above referenced products fall well within ANSI Specification A137.1-2021 for this property.

4. Breaking Strength – ASTM C-648-20

When tested as described in ASTM C-648-20, the average breaking strength shall be 250 pounds or greater.

Above referenced products fall well within ANSI Specification A137.1-2021 for the property.

5. Water Absorption – ASTM C-373-18

When tested as described in ASTM C-373-18, the tile in the sample shall have a water absorption not exceeding 5.0 percent.

Above referenced products fall well within ANSI A137.1 – 2021 for this property.

6. Dynamic Coefficient of Friction - ANSI A326.3-17

When tested as described in ANSI A236.3-17, DCOF measurements shall be equal to or greater than 0.42.

Above referenced products fall well within ANSI Specification A326.3-17 for this property.

Respectfully submitted,

SUMMITVILLE TILES, INC.



David W. Johnson
Chief Executive Officer

Terms and Conditions

The following terms (the "Terms") apply to any customer ("Customer") purchase of any Company (defined below) product ("Product").

1. Orders by Customer may be submitted by signed purchase order, which orders shall not be binding until written confirmation by General Shale Brick, Inc., or any of its subsidiaries or affiliates listed hereon (hereinafter, the "Company"). These Terms and the attached Warranty shall control over any Customer purchase order or document. The Company shall not be liable for any delay or failure to deliver any Product in case such delay or failure is caused, in whole or part, by any event or circumstance partially or fully beyond the reasonable control of the Company, including but not limited to labor disputes, strikes, war, riots, insurrection, civil disturbance, fire, flood, accident, storm, epidemic, pandemic, delays of common carriers, failure of supplies, or an act of God. When Distributor Customers place a purchase order, a shipping schedule must be included before the material can be scheduled for manufacture. ***This shipping schedule will be subject to availability in effect on date received.***
2. Unless expressly and fully excepted by the supply agreement between the Parties, all prices, to include those on the Company's price list, are subject to change for any reason including increased plant and other charges at the time of sale. Pricing does not include state, provincial, and/or local taxes, all of which are Customer's responsibility. The Company reserves the right to require pre-payment for special order or custom Product and/or storage charges in the event Customer delays scheduled delivery. Special Production products are produced ***only*** after a purchase order has been received and ***may be priced at 20% above FOB list price***. All shapes or any item not listed as a Stock item which have been ordered and produced, must be paid for whether taken or not. If material is paid for and not taken it will be subject to sale or disposal by the Company. Cancellation is not permitted after production has started.
3. Distributor Customer: Product is sold "FOB Origin-Freight Collect" and title and risk of loss transfers to Customer upon tender to Customer's carrier. Direct Customer: All risk of loss transfers to Customer upon delivery to Customer or Customer's carrier or agent. All Customers: Customer will inspect the goods immediately upon receipt and report loss or damage within 24 hours to the carrier and the Company or be barred from any claim. Customer will provide the Company with written notice of any claimed defect or breach of warranty (including claims from Customer's purchaser or any end user) as soon as possible and will, to the maximum extent possible, assist the Company in minimizing any damage(s) resulting from any claimed defect or breach of warranty. Distributor Customer: Demurrage begins 24 hours after actual or constructive placement of all cars shipped on 150,000-pound rates.
4. Invoice terms are net 30 days unless different terms have been applied to an individual account. In the event action is taken to collect from Customer, Customer shall be responsible for all costs incurred by the Company, including reasonable attorney fees. A 1.5% finance charge will be assessed on past due balances at time of statement.
5. Distributor Customer shall insure that all Product conforms to the Company's specifications before re-sale and that all packaging, including product literature and instructions, are in good order and delivered to Product purchasers. Direct Customer shall insure that all Product conforms to project specification before installation and that all packaging, including product literature and instructions, are delivered to Customer's purchaser or any end user. Customer shall indemnify, defend at its cost, and hold the Company harmless for, from, and against any and all claims, causes of action, damages, fines, judgments, penalties, costs, liabilities, losses, or expenses resulting from a breach of these obligations.
6. ***The Company makes no warranty that extends beyond the Company product description. The Company specifically disclaims and excludes any implied warranty of merchantability or fitness for a particular purpose. All goods are subject to variations permitted under applicable industry standards, including size, color, texture, chippage, or warpage. Samples (including cards) are illustrative only and may not serve as the basis for any product warranty. Product use or resale is acceptance as conforming goods.***
7. ***Customer's sole and exclusive remedy with respect to any product defect, non-conformity, or breach of warranty or contract shall be preinstallation product replacement, refunding of the purchase price at the time of original purchase, or the utilization of color correction techniques, all subject to the Company's sole discretion. The Company shall not be responsible or have any liability for any commercial loss, indirect, consequential, special, incidental, punitive, or exemplary damages for any reason, including, but not limited to any damages for replacing or removing any brick, stone, masonry, or other product from any structure. The cumulative amount of all payments, obligations, or liabilities hereunder, including for damages of any kind, shall in no event exceed the original purchase price of the particular order, lot, shipment, or the original purchase price of that portion which is not repaired or replaced (whichever lesser is applicable) with respect to which a claim is asserted.***
8. Claims of any nature pertaining to any Product shall be filed in a court of competent jurisdiction within ***one (1) year*** of delivery or be forever barred. In the event that the Company successfully defends against any claim filed by Customer, Customer shall be responsible for the Company's costs of defending said claim(s), including but not limited to reasonable attorney's fees.
9. The Company reserves, in its sole discretion, the rights to (a) suspend sales, including installment sales, to Customer if any part of Customer's account with the Company is delinquent, (b) place Customer on credit hold, and (c) demand that all Product is paid for in full prior to delivery. No goods may be returned without prior authorization, and returns are subject to applicable restocking fees.
10. Where local deliveries apply: Truck Deliveries "F.O.B. job site" will be made only on suitable and accessible surfaces. When the Customer requests delivery "inside the curb", Customer assumes all responsibility for mud tracked on streets and for any damage, including sidewalks, driveways, buildings, trees, shrubbery, lawns, silt fence, and any other structure. Delivery in separate lots is permitted.
11. Except as otherwise provided in writing, these Terms and the attached Warranty supersede any and all prior or contemporaneous understandings, negotiations, discussions, or agreements and constitute a complete, exclusive, and final written expression of all the terms of sale, and any representations, promises, warranties, or statements, or conditions by the Company or its agents that differ in any way from the terms hereof shall be given no force or effect. Only a writing signed by an Officer of the Company may amend these terms. No waiver of any provision herein shall constitute a waiver of any other provision, nor shall such waiver constitute a continuing waiver.



CERTIFICATE OF LIABILITY INSURANCE

DATE (MM/DD/YYYY)
4/16/2026

THIS CERTIFICATE IS ISSUED AS A MATTER OF INFORMATION ONLY AND CONFERS NO RIGHTS UPON THE CERTIFICATE HOLDER. THIS CERTIFICATE DOES NOT AFFIRMATIVELY OR NEGATIVELY AMEND, EXTEND OR ALTER THE COVERAGE AFFORDED BY THE POLICIES BELOW. THIS CERTIFICATE OF INSURANCE DOES NOT CONSTITUTE A CONTRACT BETWEEN THE ISSUING INSURER(S), AUTHORIZED REPRESENTATIVE OR PRODUCER, AND THE CERTIFICATE HOLDER.

IMPORTANT: If the certificate holder is an ADDITIONAL INSURED, the policy(ies) must have ADDITIONAL INSURED provisions or be endorsed. If SUBROGATION IS WAIVED, subject to the terms and conditions of the policy, certain policies may require an endorsement. A statement on this certificate does not confer rights to the certificate holder in lieu of such endorsement(s).

PRODUCER Widener Insurance Agency Inc. 607 Baxter Street Johnson City, TN 37601	CONTACT NAME: PHONE (A/C, No, Ext): (423) 926-7151	FAX (A/C, No): (423) 926-1825	
	E-MAIL ADDRESS: sandrad@widenerins.com		
INSURED K & M Flooring Inc 3901 Bristol Hwy Johnson City, TN 37601-1405	INSURER(S) AFFORDING COVERAGE		NAIC #
	INSURER A : Auto Owners Insurance		18988
	INSURER B : Accident Fund General Insurance Company		12304
	INSURER C :		
	INSURER D :		
	INSURER E :		
INSURER F :			

COVERAGES

CERTIFICATE NUMBER:

REVISION NUMBER:

THIS IS TO CERTIFY THAT THE POLICIES OF INSURANCE LISTED BELOW HAVE BEEN ISSUED TO THE INSURED NAMED ABOVE FOR THE POLICY PERIOD INDICATED. NOTWITHSTANDING ANY REQUIREMENT, TERM OR CONDITION OF ANY CONTRACT OR OTHER DOCUMENT WITH RESPECT TO WHICH THIS CERTIFICATE MAY BE ISSUED OR MAY PERTAIN, THE INSURANCE AFFORDED BY THE POLICIES DESCRIBED HEREIN IS SUBJECT TO ALL THE TERMS, EXCLUSIONS AND CONDITIONS OF SUCH POLICIES. LIMITS SHOWN MAY HAVE BEEN REDUCED BY PAID CLAIMS.

INSR LTR	TYPE OF INSURANCE	ADDL INSD	SUBR WVD	POLICY NUMBER	POLICY EFF (MM/DD/YYYY)	POLICY EXP (MM/DD/YYYY)	LIMITS
A	<input checked="" type="checkbox"/> COMMERCIAL GENERAL LIABILITY			03658615	3/3/2026	3/3/2027	EACH OCCURRENCE \$ 2,000,000
	<input type="checkbox"/> CLAIMS-MADE <input type="checkbox"/> OCCUR						DAMAGE TO RENTED PREMISES (Ea occurrence) \$ 50,000
	<input checked="" type="checkbox"/> Owner's & Contractor						MED EXP (Any one person) \$ 5,000
	GEN'L AGGREGATE LIMIT APPLIES PER:						PERSONAL & ADV INJURY \$ 2,000,000
	<input checked="" type="checkbox"/> POLICY <input type="checkbox"/> PROJECT <input type="checkbox"/> LOC						GENERAL AGGREGATE \$ 2,000,000
	OTHER:						PRODUCTS - COMP/OP AGG \$ 2,000,000
	AUTOMOBILE LIABILITY						COMBINED SINGLE LIMIT (Ea accident) \$
	<input type="checkbox"/> ANY AUTO OWNED AUTOS ONLY <input type="checkbox"/> SCHEDULED AUTOS						BODILY INJURY (Per person) \$
	<input type="checkbox"/> HIRED AUTOS ONLY <input type="checkbox"/> NON-OWNED AUTOS ONLY						BODILY INJURY (Per accident) \$
							PROPERTY DAMAGE (Per accident) \$
							\$
	UMBRELLA LIAB						EACH OCCURRENCE \$
	EXCESS LIAB						AGGREGATE \$
	DED						\$
	RETENTION \$						\$
B	WORKERS COMPENSATION AND EMPLOYERS' LIABILITY			100140624	2/18/2026	2/18/2027	PER STATUTE
	ANY PROPRIETOR/PARTNER/EXECUTIVE OFFICER/MEMBER EXCLUDED? (Mandatory in NH)		N/A				OTH-ER
	If yes, describe under DESCRIPTION OF OPERATIONS below						E.L. EACH ACCIDENT \$ 100,000
							E.L. DISEASE - EA EMPLOYEE \$ 100,000
							E.L. DISEASE - POLICY LIMIT \$ 500,000

DESCRIPTION OF OPERATIONS / LOCATIONS / VEHICLES (ACORD 101, Additional Remarks Schedule, may be attached if more space is required)

CERTIFICATE HOLDER

CANCELLATION

Washington Co. Schools
 405 W. College St.
 Jonesborough, TN 37659

SHOULD ANY OF THE ABOVE DESCRIBED POLICIES BE CANCELLED BEFORE THE EXPIRATION DATE THEREOF, NOTICE WILL BE DELIVERED IN ACCORDANCE WITH THE POLICY PROVISIONS.

AUTHORIZED REPRESENTATIVE

CES Corporation

812 Blakely Court
Knoxville TN 37924-3938
865-523-3070
cescorporation@comcast.net

TN Security License C-0376
TN Contractor License 11766

West View Elementary School Washington County Valcom Intercom April 20 2026, Bid Date

38 Each	BO-CSD2X2VRA	BOGEN CLG SPK TILE 2X2 2-PACK
1 Each	BO-WBS8WT725	BOGEN WALL BAFFLE
2 Each	BO-PS120G2	BOGEN PLATINUM 120W AMP
2 Each	BO-PSRPK	BOGEN RACK MOUNT KIT
10 Each	312/25T	FOURJAY 312 SERIES 12-WATT HORN
1 Each	6V-VACS25	VALCOM 24 ZONE INTERCOM
1 Each	VACSX7225	VALCOM 72 ZONE EXOANSION MODULE
1 Each	6V-VEADP4	VALCOM MASTER STATION
2 Each	6V-V9939C	VALVOM PAGE ADAPTOR
6 Each	VU-9208-00-8P	VERTICAL 8-BUTTON PHONE 8-PACK
2 Each	VU-9224-00	VERTICAL 24-BUTTON PHONE
43 Each	VIP-9002-WM	VERTICAL EDGE VIP9002 AND VU-9208 WM
1 Each	VS-5530-08	SUMMIT 800 MPB 800
1 Each	VS-5500-00	SUMMIT 800 BASIC KSU
1 Each	VS-5571-00	SUMMIT POWER SUPPLY
1 Each	VS-5531-12	SUMMIT 800 12DTIB, LCOB
1 Each	VS-5532-24	SUMMIT 24 DKT INTERFACE
2 Each	M2-52M	BLOCK MALE CONNECTORS
4 Each	253PC15GY	ALLEN TEL 15 FT PC CABLE
1 Each	XCW1P24RDWHSGCC	CROSS CONNECT RED AND WHITE
1 Each	XCXIP24BLWHSGCC	CROSS CONNECT BLUE WHITE
LABOR	INSTALLATION LABOR AND PROGRAMMING	

Grand Total: \$52,975.00

State of Tennessee

15140978

BOARD FOR LICENSING CONTRACTORS
CONTRACTOR
CES CORPORATION

This is to certify that all requirements of the State of Tennessee have been met.

ID NUMBER: 11766
LIC STATUS: ACTIVE
EXPIRATION DATE: April 30, 2028
\$700,000.00; CE-D; CE-G



IN-1313
DEPARTMENT OF
COMMERCE AND INSURANCE



CESCORP-01

ACRISTY

CERTIFICATE OF LIABILITY INSURANCE

DATE (MM/DD/YYYY)
7/31/2025

THIS CERTIFICATE IS ISSUED AS A MATTER OF INFORMATION ONLY AND CONFERS NO RIGHTS UPON THE CERTIFICATE HOLDER. THIS CERTIFICATE DOES NOT AFFIRMATIVELY OR NEGATIVELY AMEND, EXTEND OR ALTER THE COVERAGE AFFORDED BY THE POLICIES BELOW. THIS CERTIFICATE OF INSURANCE DOES NOT CONSTITUTE A CONTRACT BETWEEN THE ISSUING INSURER(S), AUTHORIZED REPRESENTATIVE OR PRODUCER, AND THE CERTIFICATE HOLDER.

IMPORTANT: If the certificate holder is an ADDITIONAL INSURED, the policy(ies) must have ADDITIONAL INSURED provisions or be endorsed. If SUBROGATION IS WAIVED, subject to the terms and conditions of the policy, certain policies may require an endorsement. A statement on this certificate does not confer rights to the certificate holder in lieu of such endorsement(s).

PRODUCER Oakbridge Insurance Agency 10325 Technology Dr, Knoxville, TN 37932	CONTACT NAME: Heather Long, CPCU	
	PHONE (A/C, No, Ext): (865) 675-6500 3401	FAX (A/C, No): (865) 675-0866
E-MAIL ADDRESS: hlong@oakbridgeinsurance.com		
INSURER(S) AFFORDING COVERAGE		NAIC #
INSURER A: Landmark American Ins Co		33138
INSURER B: Frankenmuth Insurance Company		13986
INSURER C:		
INSURER D:		
INSURER E:		
INSURER F:		

INSURED

CES Corporation
 PO Box 14620
 Knoxville, TN 37914

COVERAGES **CERTIFICATE NUMBER:** **REVISION NUMBER:**

THIS IS TO CERTIFY THAT THE POLICIES OF INSURANCE LISTED BELOW HAVE BEEN ISSUED TO THE INSURED NAMED ABOVE FOR THE POLICY PERIOD INDICATED. NOTWITHSTANDING ANY REQUIREMENT, TERM OR CONDITION OF ANY CONTRACT OR OTHER DOCUMENT WITH RESPECT TO WHICH THIS CERTIFICATE MAY BE ISSUED OR MAY PERTAIN, THE INSURANCE AFFORDED BY THE POLICIES DESCRIBED HEREIN IS SUBJECT TO ALL THE TERMS, EXCLUSIONS AND CONDITIONS OF SUCH POLICIES. LIMITS SHOWN MAY HAVE BEEN REDUCED BY PAID CLAIMS.

INSR LTR	TYPE OF INSURANCE	ADDL INSD	SUBR WVD	POLICY NUMBER	POLICY EFF (MM/DD/YYYY)	POLICY EXP (MM/DD/YYYY)	LIMITS
A	<input checked="" type="checkbox"/> COMMERCIAL GENERAL LIABILITY <input type="checkbox"/> CLAIMS-MADE <input checked="" type="checkbox"/> OCCUR GEN'L AGGREGATE LIMIT APPLIES PER: <input type="checkbox"/> POLICY <input checked="" type="checkbox"/> PRO-JECT <input type="checkbox"/> LOC OTHER:			LHA115330	8/1/2025	8/1/2026	EACH OCCURRENCE \$ 1,000,000 DAMAGE TO RENTED PREMISES (Ea occurrence) \$ 50,000 MED EXP (Any one person) \$ PERSONAL & ADV INJURY \$ 1,000,000 GENERAL AGGREGATE \$ 2,000,000 PRODUCTS - COMP/OP AGG \$ 2,000,000
B	<input checked="" type="checkbox"/> AUTOMOBILE LIABILITY <input checked="" type="checkbox"/> ANY AUTO OWNED AUTOS ONLY <input type="checkbox"/> SCHEDULED AUTOS <input type="checkbox"/> HIRED AUTOS ONLY <input type="checkbox"/> NON-OWNED AUTOS ONLY			6655189	3/1/2025	3/1/2026	COMBINED SINGLE LIMIT (Ea accident) \$ 1,000,000 BODILY INJURY (Per person) \$ BODILY INJURY (Per accident) \$ PROPERTY DAMAGE (Per accident) \$
A	<input checked="" type="checkbox"/> UMBRELLA LIAB <input checked="" type="checkbox"/> OCCUR <input checked="" type="checkbox"/> EXCESS LIAB <input type="checkbox"/> CLAIMS-MADE DED <input checked="" type="checkbox"/> RETENTION \$ 0			LHA608089	8/1/2025	8/1/2026	EACH OCCURRENCE \$ 1,000,000 AGGREGATE \$ 1,000,000
B	WORKERS COMPENSATION AND EMPLOYERS' LIABILITY ANY PROPRIETOR/PARTNER/EXECUTIVE OFFICER/MEMBER EXCLUDED? (Mandatory in NH) <input checked="" type="checkbox"/> Y <input checked="" type="checkbox"/> N If yes, describe under DESCRIPTION OF OPERATIONS below		N/A	6663898	8/1/2025	8/1/2026	<input checked="" type="checkbox"/> PER STATUTE <input type="checkbox"/> OTH-ER E.L. EACH ACCIDENT \$ 500,000 E.L. DISEASE - EA EMPLOYEE \$ 500,000 E.L. DISEASE - POLICY LIMIT \$ 500,000

DESCRIPTION OF OPERATIONS / LOCATIONS / VEHICLES (ACORD 101, Additional Remarks Schedule, may be attached if more space is required)

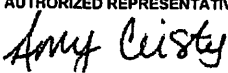
CERTIFICATE HOLDER FOR INFORMATION ONLY	CANCELLATION SHOULD ANY OF THE ABOVE DESCRIBED POLICIES BE CANCELLED BEFORE THE EXPIRATION DATE THEREOF, NOTICE WILL BE DELIVERED IN ACCORDANCE WITH THE POLICY PROVISIONS. AUTHORIZED REPRESENTATIVE 
---	--

Advanced Communication System



The Advanced Communication System, or V-ACS, is a compact, wall mounted intercom system designed to meet the needs of small to medium size commercial, government and K-12 facilities. The ACS is easy-to-install and integrates with any telephone system or a stand-alone phone. It is programmed with a user-friendly Windows-based software that helps you to easily manage schedules, caller ID descriptions from call buttons, alert tones, department moves or room changes.

The ACS works with your existing systems to give you the flexibility to manage your daily operations over your network.

Accessories

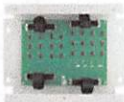

4-Station Cable Adapter
(use w/ V-ACS45 only)
V-CA2924



A compact, yet powerful communications and emergency system.

ACS Advanced Communication System

- 24 Zones (25 Volt) V-ACS25
- Expands the V-ACS25 to 48 Zone V-ACS-X48/25
- Expands the V-ACS25 to 72 Zone V-ACS-X72/25

- 24 Zones (45 Ohm) V-ACS45
- Expands the V-ACS45 to 48 Zone V-ACS-X48/45
- Expands the V-ACS45 to 72 Zone V-ACS-X72/45



THE SUM OF ALL YOUR BUSINESS COMMUNICATIONS



VERTICAL SUMMIT

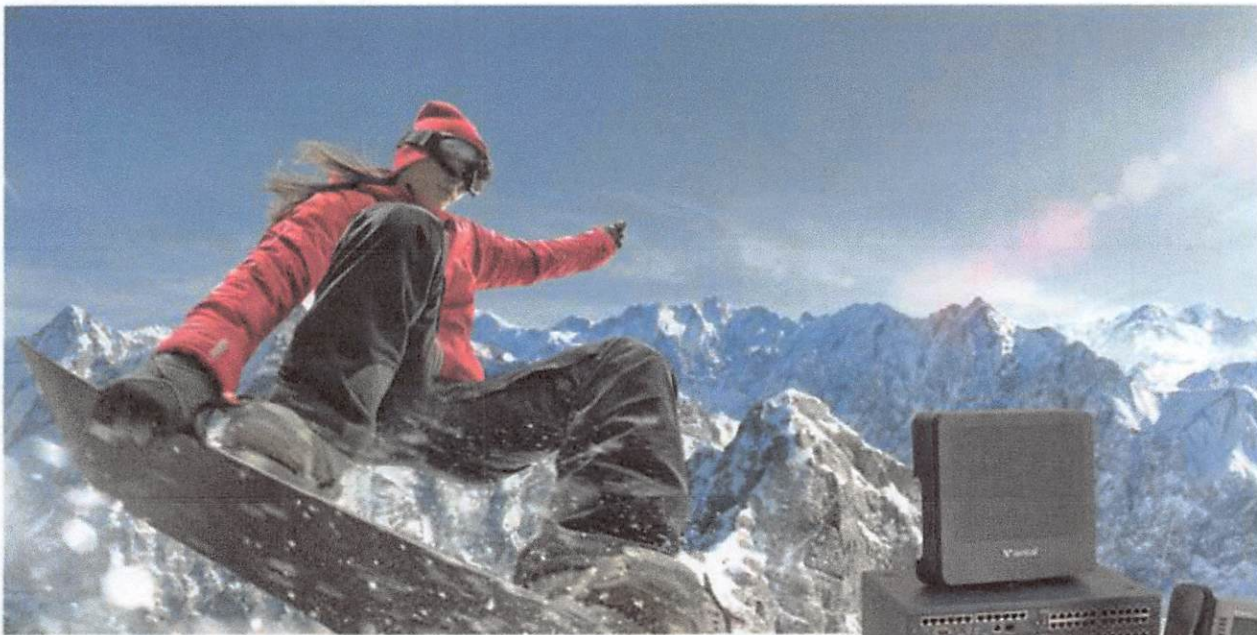

COMMUNICATIONS FOR PEAK PERFORMANCE

Voice. UC. BYOD. Mobile.

Now you can have it all – with the versatile Vertical Summit™ unified communications (UC) platform. More than a simple phone system, the Summit gives you cost-effective options that add up to real-time communications and bottom-line business benefits with the ability to easily – and affordably – migrate from analog to IP for true mobility and more. Simple to set up and administer, the Summit's optimized IP/TDM hybrid architecture gives you all the standard features you need while supporting more advanced UC and mobility applications, so you can communicate and collaborate seamlessly wherever your business takes you.

In addition to standard call handling features including one-touch call transfer, call recording, Caller ID and music on hold, the Vertical Summit offers more advanced functions through integrated applications and features such as a multi-level Auto Attendant and voice mail with email notification; at-a-glance presence management and call routing capabilities; videoconferencing; and even the ability to place calls by simply clicking on a number in a Windows-based Web page or document.

Key Features

- UCS Desktop Client with Voice (Softphone)
- UCS Mobile Client
- Presence
- 1:1 Video Calling
- Secure IM
- ClickCall
- Voice & Videoconferencing
- Advanced Call Recording
- Visual Voice Mail
- Automatic Call Distribution (ACD)
- Auto Attendant
- Mobile & SIP Extensions
- Dedicated Hospitality Telephony Suite
- Green Power Save

Your License to Communicate

To ensure peak performance from the Summit's powerful suite of multimedia, collaboration and productivity tools and applications, each system includes licenses for the standard Summit Unified Communications Solution (UCS) Desktop Client with Voice (softphone), as well as Summit UCS Mobile Client licenses.* The Summit's UCS clients give you seamless, single-number connectivity to customers, co-workers and features from your PC or smartphone, so you can:

- Make, receive and transfer calls from anywhere with one touch
- Quickly handle calls with at-a-glance, presence-based call management and individual call routing
- Access directories, call logs, paging and other system features with the tap of a finger
- Automatically integrate and synchronize private and shared directories with your contacts and schedule for more efficient communications
- Send and receive secure IM, text and broadcast messages
- Easily set up and manage videoconferences with up to six people
- Share applications, white boards and desktops in real time
- Record calls with a single click
- Conduct 3-way conference calling



Summit UCS Desktop & Mobile Clients

Optimize Your Communications with Optional Applications

To get peak performance from your Summit system, optional applications are available to further enhance your business's communications capabilities and bottom line.

IPCR Call Recording – Ensure compliance with regulatory requirements and improve employee training and customer service with more advanced call recording capabilities. IPCR Call Recording lets you securely record and monitor calls to and from any phone on your Summit system on demand or systemwide, and quickly search, retrieve and replay calls via your Web browser.

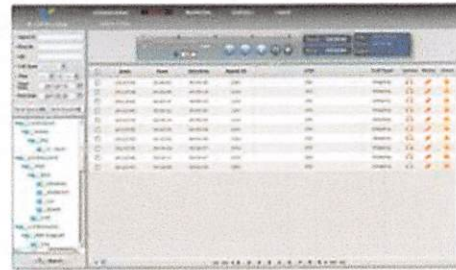

IP Attendant (Office/Hotel) – Streamline call handling and distribution with simplified control of the Summit's Attendant features and functions via this easy-to-use interface and high voice quality, built-in IP softphone. IP Attendant software displays call, user and system status for standard office use, and is also available with a dedicated hospitality telephony feature set that integrates with various hotel/motel property management systems.



ClickCall – Now you can make calls from numbers in any Windows-based application, Web page, or document without dialing your phone. Save time and eliminate misdials by simply highlighting the number and dragging it into the ClickCall pop-up window to place the call automatically from your desktop phone.



**Vertical Summit includes 2 standard UCS Desktop Client w/Voice and 2 UCS Mobile Client licenses. Summit 800 includes 5 standard UCS Desktop Client w/Voice and 5 UCS Mobile Client licenses. Additional UCS Client licenses sold separately.*

Affordable Expandability

Easy to set up, maintain and use, each Summit platform gives you the flexibility to design an affordable, dynamic communications system that's truly the best fit for your business with:

- Advanced VoIP technology
- Low cost SIP trunking
- On/off premise mobility
- Remote connectivity

With the Summit, you can easily expand your communications infrastructure as your business grows with extra expansion units to serve up to 800 users.

The Summit is also compatible with Vertical's SBX IP and MBX IP platforms, so you can quickly network up to 250 sites together while creating a simple migration path to the full-feature and cost-saving benefits of the Summit's built-in VoIP technology.



The cost effective Vertical Summit™ platform is ideally suited for small businesses with five to 50 users, and with optional expansion unit, can accommodate up to 140.

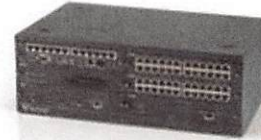

The easily expandable Vertical Summit™ 800 system delivers both digital and VoIP capabilities to small and medium-sized businesses in a single, cost-effective system for 50 and up to 800 users.

Flexible Phone Options

Get the most out of the Summit's feature set with Vertical's new Edge 9000 Series IP and digital phones and DECT phones featuring display-based interfaces, call logs, self-labeling keys and simplified administration. The optional Summit Wireless DECT System let's you cost-effectively increase your coverage, voice traffic and number of users with up to 48 additional extensions. The Summit also integrates with other Vertical SBX IP and MBX IP digital, SIP and IP phones, as well as Vodavi single-line analog, XTS, STS and Triad phones to protect and extend your current communications capabilities and investment.



*Edge 9000 Series
IP Phones*



*Edge 9000 Series
Digital Phones*



*Nomad IP WiFi
Phone*



Summit Wireless DECT System

For more information on the Vertical Summit, visit www.vertical.com, call 1-877-VERTICAL, or contact an authorized Vertical Summit dealer.

Corporate Headquarters

3900 Freedom Circle
Suite 110
Santa Clara, CA 95054
Phone: (408) 404-1600
FAX: (408) 969-9601

Sales & Service

1000 Holcomb Woods Parkway
Bldg. 300, Suite 300
Roswell, GA 30076
Phone: (770) 446-3100

RMA & Technical Support

4717 East Hilton Avenue
Suite 400
Phoenix, AZ 85034
Phone: (480) 374-8900
FAX: (480) 374-8852



BOGEN

DROP-IN CEILING SPEAKERS

EASY TO INSTALL CEILING TILE SPEAKERS - SIMPLY CONNECT AND DROP INTO PLACE



Available In
A Variety of
Styles to Meet
Your Needs

CSD1X2

- 1 ft. x 2 ft. with back can enclosure
- 70V/25V, 4W transformer (4, 2, 1, 0.5, 0.25 watt) taps; selected by rotary switch
- 8" main speaker cone with 10 oz. magnet, plus secondary high-frequency cone
- Front-mounted, recessed volume control available (VR)



Available In
2 Color Choices:
Off-white and
Bright White



CSD2X2

- 2 ft. x 2 ft. with back can enclosure
- 70V/25V, 4W transformer (4, 2, 1, 0.5, 0.25 watt) taps; selected by rotary switch
- 8" main speaker cone with 10 oz. magnet, plus secondary high-frequency cone
- Front-mounted, recessed volume control available (VR)

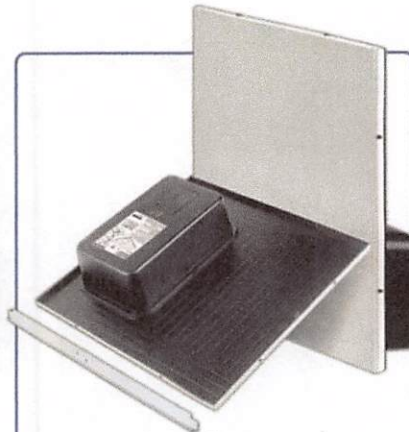

CSD2X2L

- 2 ft. x 2 ft. with back can enclosure
- Low-impedance: 8-ohm speaker, 15W maximum power
- 8" main speaker cone with 10 oz. magnet, plus secondary high-frequency cone



ACD2X2

- 2 ft. x 2 ft. with back can enclosure
- Self-contained 1-watt amplifier
- For 24V, self-amplified systems, or as add-on to expand other systems
- 8" main speaker cone with 10 oz. magnet, plus secondary high-frequency cone
- Front-mounted, recessed volume control

CSD1X2, CSD2X2, and ACD2X2 Series Drop-In Ceiling Speakers

All Models Feature:

Finely perforated grille over entire front of speaker • Industrial-grade Steel Construction
Choose Bright White or Off-white Grille Finish • Support Rail Crossbar (included) • Seismic Attachment Points

These ceiling speakers are fast and easy to install, and fit into standard 2 ft. x 2 ft. or 2 ft. x 4 ft. grids.

- 1 Place speaker in ceiling grid.
- 2 Make a simple cut to the ceiling tile (if necessary).
- 3 Lay Tile Support Rail across ceiling grid (if necessary).
- 4 Drop speaker into place.

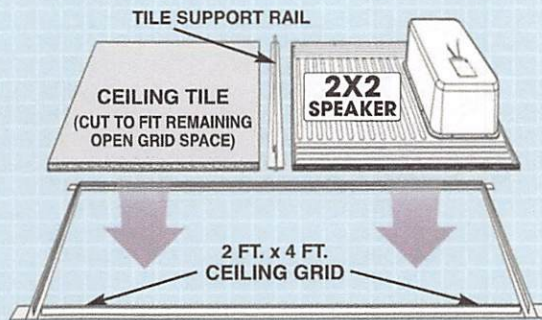
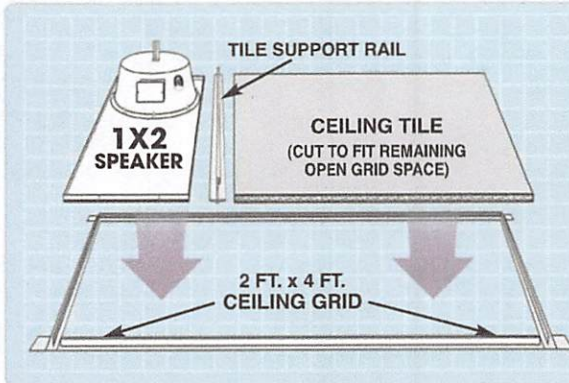
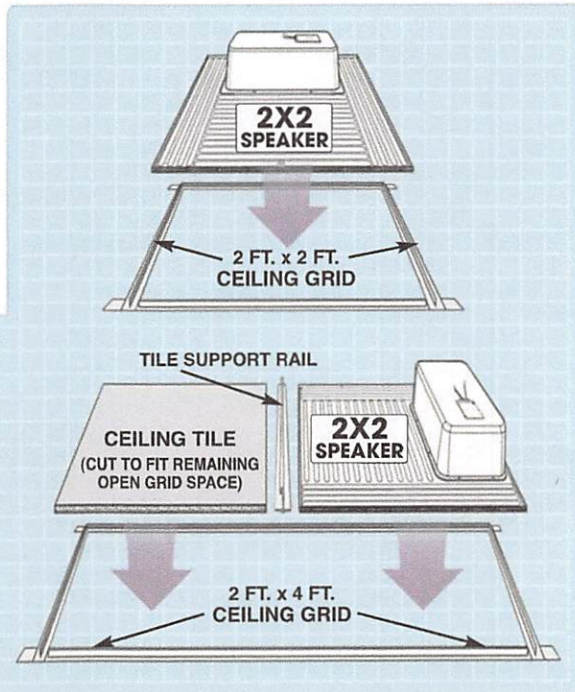

Model	Speaker Size		Grille Color		Impedance			Speaker Back Can	Recessed Volume Control
	1 ft. x 2 ft.	2 ft. x 2 ft.	Off-white	Bright White	70V/25V (4W max.)	8-ohm (15W max.)	24V Self-Amplified (1W max.)		
CSD1X2	●		●		●			●	
CSD1X2U	●			●	●			●	
CSD1X2VR	●		●		●			●	●
CSD1X2VRU	●			●	●			●	●
CSD2X2		●	●		●			●	
CSD2X2U		●		●	●			●	
CSD2X2VR		●	●		●			●	●
CSD2X2VRU		●		●	●			●	●
CSD2X2L		●	●			●		●	
CSD2X2LU		●		●		●		●	
ACD2X2		●	●				●	●	●
ACD2X2U		●		●			●	●	●

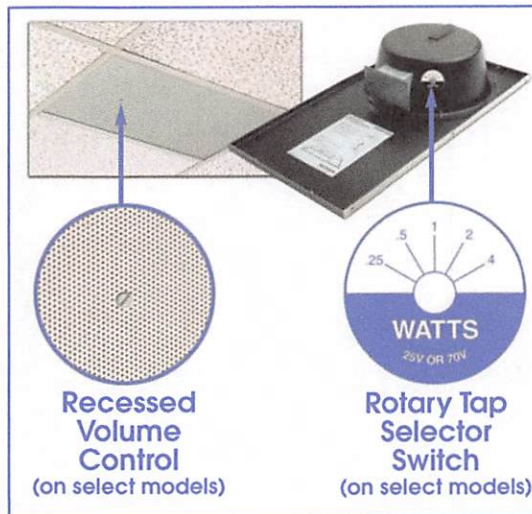

For complete specifications of all models, visit: www.bogen.com



12 Watt Reflex Horn Speaker

for Music & Paging

312 Series

- Reflex horn speaker with good frequency range for music and paging applications in moderately noisy environments.
- Power rating 12 watts, continuous duty.
- Unique mounting base design offers quick and easy mounting and adjustment.
- Two hole patterns allow assembly of base plate to various electrical boxes.
- Strong but lightweight construction of impact & UV resistant ABS with polycarbonate base assembly and stainless steel fasteners.
- Polycarbonate base plate is strong enough to be mounted with stud gun or concrete nails.
- May be recess mounted - hole locations are dimpled on back of flange.
- Attractive tan color.
- 25 or 70.7 volt models are tapped with 5-conductor color coded cable.
- Manufactured in Fourjay's plant under strict quality requirements.

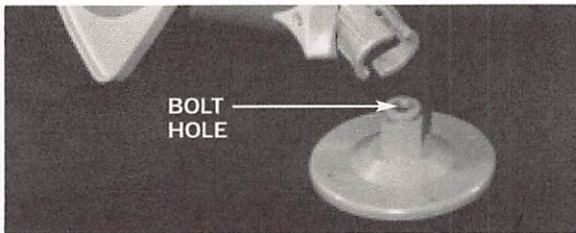

MODEL NO.	RATED INPUT	INPUT TAPS		WT. (lbs.)
		WATTS	OHMS ($\pm 10\%$)	
312-8	8 ohms	12	8	2
312/25-T	25 V line	12,6,3,1	52,104,208,625	2-1/2
312/70-T	70.7 V line	12,6,3,1	415,830,1660,5000	2-1/2

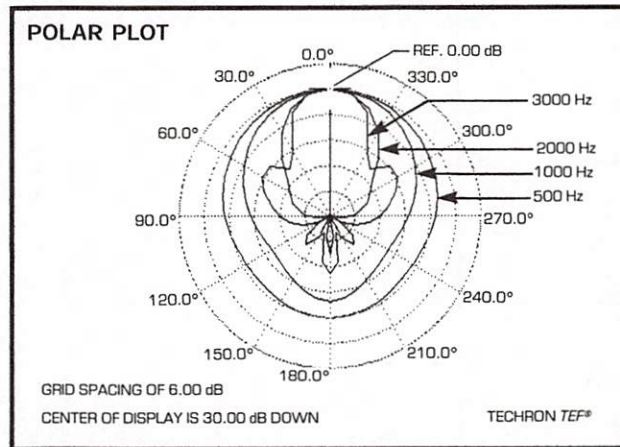
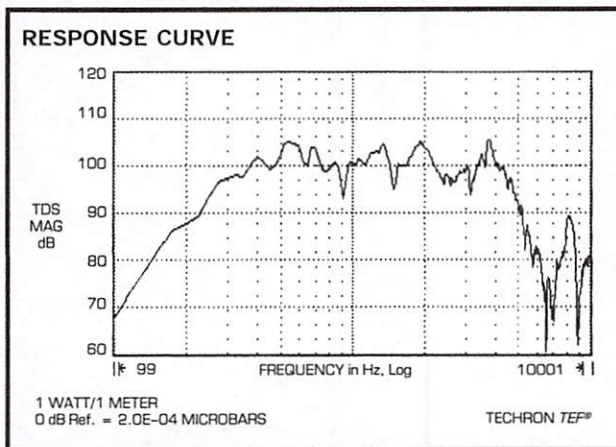

FOURJAY SINCE 1956
INDUSTRIES, INC.

3400 STOP EIGHT ROAD • P.O. BOX 13617 • DAYTON, OH 45413-0617
TELEPHONE (937) 890-6444 • FAX (800) 4J HORNS (454-6767)
WEBSITE: <http://www.fourjay.com> • EMAIL: 4j@fourjay.com

Fourjay Quality—American Made

IN STOCK

IMMEDIATE SHIPMENT

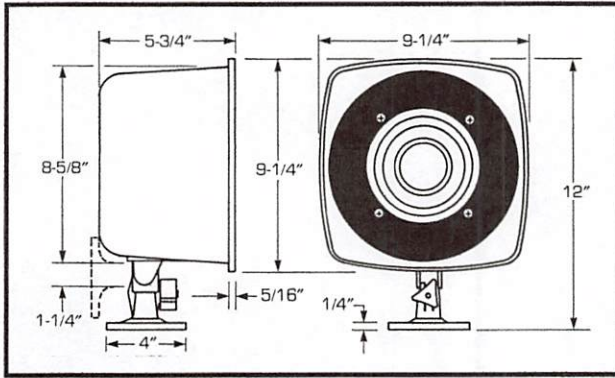

TECHNICAL SPECIFICATIONS

Power Handling: 12 watts continuous duty.

Frequency Range: 230-5000 Hz (± 6 dB)
(On Axis) 140-6200 Hz (± 12 dB)

Sound Pressure Level: (Model 312-8 at 1 meter)
• 1 watt, 500-5000 Hz, averaged; 101 dB
• 12 watts, 500-5000 Hz, averaged; 112 dB

5 CONDUCTOR INPUT CABLE POWER TAP CODE

MODELS	BLK	BRN	GRN	RED	WH
312/25-T 312/70-T	COM	12W	6W	3W	1W

PHYSICAL SPECIFICATIONS

Materials: Impact resistant ABS horn. High stability polycarbonate mounting components. Stainless steel fasteners.

Driver: Cone type, 5-1/4" diameter loudspeaker. Steel parts plated to resist corrosion.

Mounting Provisions: Fully adjustable, 2-axis, positive spline lock mounting assembly. Removable polycarbonate base mounts to electrical boxes. Dimpled hole locators in flange for recessed mounting.

Color: Tan.

Wiring: 2-conductor black jacketed 18-gauge cable on Model 312-8. Color coded 5-conductor 20-gauge black jacketed cable on Model 312/25-T and 312/70-T.

ARCHITECT'S & ENGINEER'S SPECIFICATIONS

The loudspeaker shall be a reflex driver type horn projector of integrated construction, Fourjay Model (312-8, 312/25-T, 312/70-T). It shall be rated 12 watts for voice or music material with an on-axis frequency response of 230 to 5000 Hz (± 6 dB). The sound pressure level shall average 101 dB (1W/1M) for 500 to 5000 Hz.

The horn shall be tan in color and constructed of impact & UV resistant ABS with a matching color base assembly constructed of polycarbonate. All materials shall resist damage from extreme weather exposure and will retain mechanical properties from -20° to $+160^{\circ}$ F.

The mounting Provisions shall be a fully adjustable, 2-axis, positive spline lock assembly with removable base that will mount to many electrical boxes, or recess mounted using horn flange.

MOUNTING METHODS AND ACCESSORIES

KBC123 Kit Beam Clamp Mount	KBJ123 Kit Bar Joist Mount	KTG123 Kit Toggle Bolt Mount	KPM123 Kit Pole Mount
Stud Driver or Concrete Nails	Mounting to Electrical Boxes		



FOURJAY SINCE 1956
INDUSTRIES, INC.

3400 STOP EIGHT ROAD • P.O. BOX 13617 • DAYTON, OH 45413-0617
TELEPHONE (937) 890-6444 • FAX (800) 4J HORNS (454-6767)
WEBSITE: <http://www.fourjay.com> • EMAIL: 4j@fourjay.com

Fourjay Quality—American Made

CES Corporation

812 Blakely Court
Knoxville TN 37924-3938
865-523-3070
cescorporation@comcast.net

TN Security License C-0376
TN Contractor License 11766

David Crockett High School Washington County Valcom Intercom April 20 2026, Bid Date

60 Each	BO-CSD2X2VRA	BOGEN CLG SPK TILE 2X2 2-PACK
2 Each	BO-PS120G2	BOGEN PLATINUM 120W AMP
2 Each	BO-PSRPK	BOGEN RACK MOUNT KIT
24 Each	312/25T	FOURJAY 312 SERIES 12-WATT HORN
1 Each	6V-VACS25	VALCOM 24 ZONE INTERCOM
1 Each	VACSX7225	VALCOM 72 ZONE EXPANSION MODULE
1 Each	6V-VEADP4	VALCOM MASTER STATION
2 Each	6V-V9939C	VALVOM PAGE ADAPTOR
10 Each	VU-9208-00-8P	VERTICAL 8-BUTTON PHONE 8-PACK
4 Each	VU-9224-00	VERTICAL 24-BUTTON PHONE
75 Each	VIP-9002-WM	VERTICAL EDGE VIP9002 AND VU-9208 WM
1 Each	VS-5530-08	SUMMIT 800 MPB 800
1 Each	VS-5500-00	SUMMIT 800 BASIC KSU
1 Each	VS-5571-00	SUMMIT POWER SUPPLY
1 Each	VS-5531-12	SUMMIT 800 12DTIB, LCOB
1 Each	VS-5532-24	SUMMIT 24 DKT INTERFACE
12 Each	G4-M150	CONNECTOR BLOCK 66M150
12 Each	G4-S89D	MOUNTING BRACKET FOR 66M150
4 Each	M2-52M	BLOCK MALE CONNECTORS
4 Each	WG-21211101	HONEYWELL 16/2 WHITE STRANDED
4 Each	253PC15GY	ALLEN TEL 15 FT PC CABLE
1 Each	XCW1P24RDWHSGCC	CROSS CONNECT RED AND WHITE
1 Each	XCXIP24BLWHSGCC	CROSS CONNECT BLUE WHITE
LABOR	INSTALLATION LABOR AND PROGRAMMING	

Grand Total: \$79,900.00

State of Tennessee

15140978

BOARD FOR LICENSING CONTRACTORS
CONTRACTOR
CES CORPORATION

This is to certify that all requirements of the State of Tennessee have been met.

ID NUMBER: 11766
LIC STATUS: ACTIVE
EXPIRATION DATE: April 30, 2028
\$700,000.00; CE-D; CE-G



IN-1313
DEPARTMENT OF
COMMERCE AND INSURANCE

Advanced Communication System



The Advanced Communication System, or V-ACS, is a compact, wall mounted intercom system designed to meet the needs of small to medium size commercial, government and K-12 facilities. The ACS is easy-to-install and integrates with any telephone system or a stand-alone phone. It is programmed with a user-friendly Windows-based software that helps you to easily manage schedules, caller ID descriptions from call buttons, alert tones, department moves or room changes.

The ACS works with your existing systems to give you the flexibility to manage your daily operations over your network.

Accessories

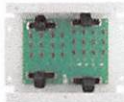

4-Station Cable Adapter
(use w/ V-ACS45 only)
V-CA2924



A compact, yet powerful communications and emergency system.

ACS Advanced Communication System

24 Zones (25 Volt) V-ACS25
Expands the V-ACS25 to 48 Zone V-ACS-X48/25
Expands the V-ACS25 to 72 Zone V-ACS-X72/25

24 Zones (45 Ohm) V-ACS45
Expands the V-ACS45 to 48 Zone V-ACS-X48/45
Expands the V-ACS45 to 72 Zone V-ACS-X72/45



THE SUM OF ALL YOUR BUSINESS COMMUNICATIONS



VERTICAL SUMMIT

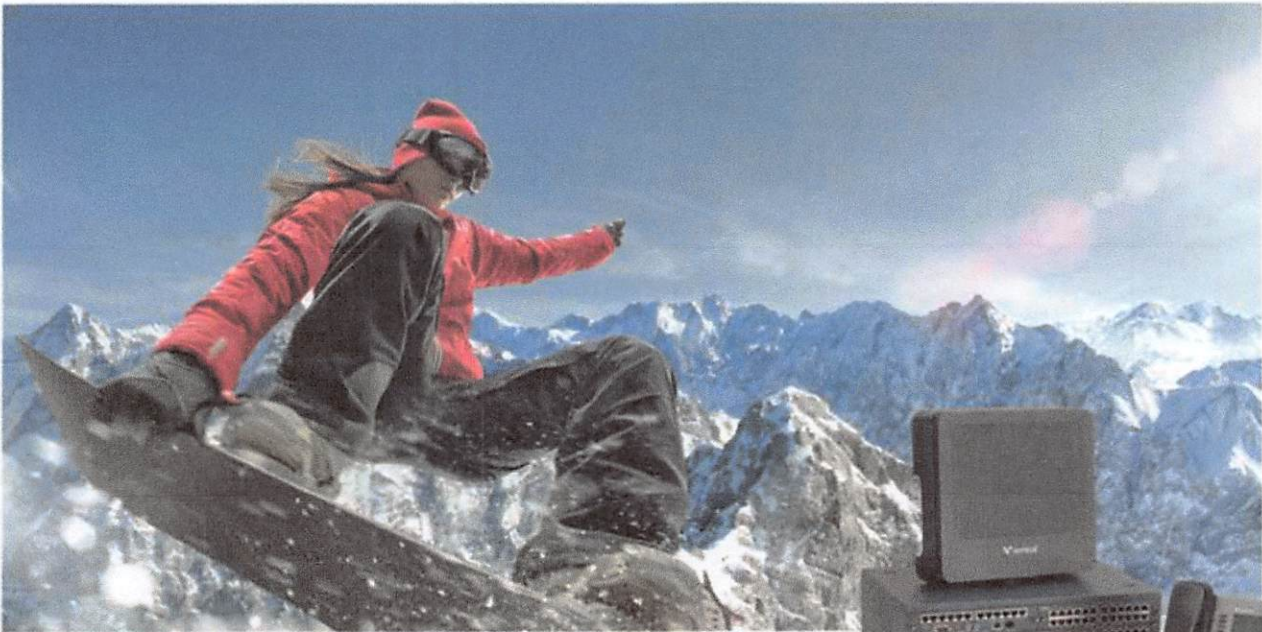

COMMUNICATIONS FOR PEAK PERFORMANCE

Voice. UC. BYOD. Mobile.

Now you can have it all – with the versatile Vertical Summit™ unified communications (UC) platform. More than a simple phone system, the Summit gives you cost-effective options that add up to real-time communications and bottom-line business benefits with the ability to easily – and affordably – migrate from analog to IP for true mobility and more. Simple to set up and administer, the Summit's optimized IP/TDM hybrid architecture gives you all the standard features you need while supporting more advanced UC and mobility applications, so you can communicate and collaborate seamlessly wherever your business takes you.

In addition to standard call handling features including one-touch call transfer, call recording, Caller ID and music on hold, the Vertical Summit offers more advanced functions through integrated applications and features such as a multi-level Auto Attendant and voice mail with email notification; at-a-glance presence management and call routing capabilities; videoconferencing; and even the ability to place calls by simply clicking on a number in a Windows-based Web page or document.

Key Features

- UCS Desktop Client with Voice (Softphone)
- UCS Mobile Client
- Presence
- 1:1 Video Calling
- Secure IM
- ClickCall
- Voice & Videoconferencing
- Advanced Call Recording
- Visual Voice Mail
- Automatic Call Distribution (ACD)
- Auto Attendant
- Mobile & SIP Extensions
- Dedicated Hospitality Telephony Suite
- Green Power Save

Your License to Communicate

To ensure peak performance from the Summit's powerful suite of multimedia, collaboration and productivity tools and applications, each system includes licenses for the standard Summit Unified Communications Solution (UCS) Desktop Client with Voice (softphone), as well as Summit UCS Mobile Client licenses.* The Summit's UCS clients give you seamless, single-number connectivity to customers, co-workers and features from your PC or smartphone, so you can:

- Make, receive and transfer calls from anywhere with one touch
- Quickly handle calls with at-a-glance, presence-based call management and individual call routing
- Access directories, call logs, paging and other system features with the tap of a finger
- Automatically integrate and synchronize private and shared directories with your contacts and schedule for more efficient communications
- Send and receive secure IM, text and broadcast messages
- Easily set up and manage videoconferences with up to six people
- Share applications, white boards and desktops in real time
- Record calls with a single click
- Conduct 3-way conference calling



Summit UCS Desktop & Mobile Clients

Optimize Your Communications with Optional Applications

To get peak performance from your Summit system, optional applications are available to further enhance your business's communications capabilities and bottom line.

IPCR Call Recording – Ensure compliance with regulatory requirements and improve employee training and customer service with more advanced call recording capabilities. IPCR Call Recording lets you securely record and monitor calls to and from any phone on your Summit system on demand or systemwide, and quickly search, retrieve and replay calls via your Web browser.

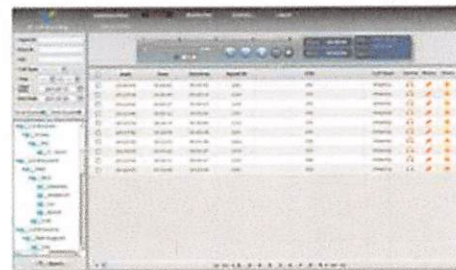

IP Attendant (Office/Hotel) – Streamline call handling and distribution with simplified control of the Summit's Attendant features and functions via this easy-to-use interface and high voice quality, built-in IP softphone. IP Attendant software displays call, user and system status for standard office use, and is also available with a dedicated hospitality telephony feature set that integrates with various hotel/motel property management systems.



ClickCall – Now you can make calls from numbers in any Windows-based application, Web page, or document without dialing your phone. Save time and eliminate misdials by simply highlighting the number and dragging it into the ClickCall pop-up window to place the call automatically from your desktop phone.



**Vertical Summit includes 2 standard UCS Desktop Client w/Voice and 2 UCS Mobile Client licenses. Summit 800 includes 5 standard UCS Desktop Client w/Voice and 5 UCS Mobile Client licenses. Additional UCS Client licenses sold separately.*

Affordable Expandability

Easy to set up, maintain and use, each Summit platform gives you the flexibility to design an affordable, dynamic communications system that's truly the best fit for your business with:

- Advanced VoIP technology
- Low cost SIP trunking
- On/off premise mobility
- Remote connectivity

With the Summit, you can easily expand your communications infrastructure as your business grows with extra expansion units to serve up to 800 users.

The Summit is also compatible with Vertical's SBX IP and MBX IP platforms, so you can quickly network up to 250 sites together while creating a simple migration path to the full-feature and cost-saving benefits of the Summit's built-in VoIP technology.



The cost effective Vertical Summit™ platform is ideally suited for small businesses with five to 50 users, and with optional expansion unit, can accommodate up to 140.

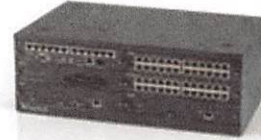

The easily expandable Vertical Summit™ 800 system delivers both digital and VoIP capabilities to small and medium-sized businesses in a single, cost-effective system for 50 and up to 800 users.

Flexible Phone Options

Get the most out of the Summit's feature set with Vertical's new Edge 9000 Series IP and digital phones and DECT phones featuring display-based interfaces, call logs, self-labeling keys and simplified administration. The optional Summit Wireless DECT System let's you cost-effectively increase your coverage, voice traffic and number of users with up to 48 additional extensions. The Summit also integrates with other Vertical SBX IP and MBX IP digital, SIP and IP phones, as well as Vodavi single-line analog, XTS, STS and Triad phones to protect and extend your current communications capabilities and investment.



*Edge 9000 Series
IP Phones*



*Edge 9000 Series
Digital Phones*



*Nomad IP WiFi
Phone*



Summit Wireless DECT System

For more information on the Vertical Summit, visit www.vertical.com, call 1-877-VERTICAL, or contact an authorized Vertical Summit dealer.

Corporate Headquarters

3900 Freedom Circle
Suite 110
Santa Clara, CA 95054
Phone: (408) 404-1600
FAX: (408) 969-9601

Sales & Service

1000 Holcomb Woods Parkway
Bldg. 300, Suite 300
Roswell, GA 30076
Phone: (770) 446-3100

RMA & Technical Support

4717 East Hilton Avenue
Suite 400
Phoenix, AZ 85034
Phone: (480) 374-8900
FAX: (480) 374-8852



BOGEN

DROP-IN CEILING SPEAKERS

EASY TO INSTALL CEILING TILE SPEAKERS - SIMPLY CONNECT AND DROP INTO PLACE



Available In
A Variety of
Styles to Meet
Your Needs

CSD1X2

- 1 ft. x 2 ft. with back can enclosure
- 70V/25V, 4W transformer (4, 2, 1, 0.5, 0.25 watt) taps; selected by rotary switch
- 8" main speaker cone with 10 oz. magnet, plus secondary high-frequency cone
- Front-mounted, recessed volume control available (VR)



Available In
2 Color Choices:
Off-white and
Bright White

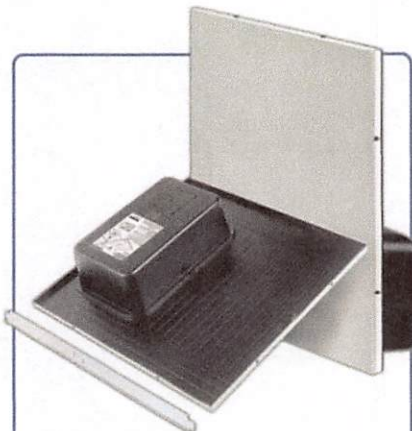

CSD2X2

- 2 ft. x 2 ft. with back can enclosure
- 70V/25V, 4W transformer (4, 2, 1, 0.5, 0.25 watt) taps; selected by rotary switch
- 8" main speaker cone with 10 oz. magnet, plus secondary high-frequency cone
- Front-mounted, recessed volume control available (VR)

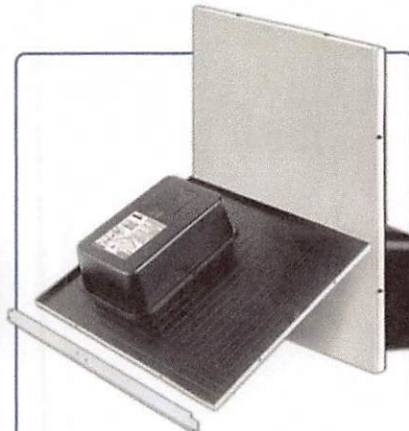

CSD2X2L

- 2 ft. x 2 ft. with back can enclosure
- Low-impedance: 8-ohm speaker, 15W maximum power
- 8" main speaker cone with 10 oz. magnet, plus secondary high-frequency cone

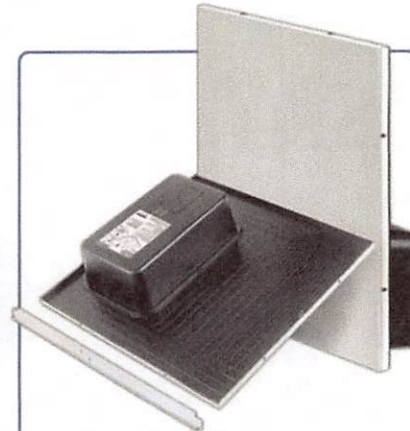

ACD2X2

- 2 ft. x 2 ft. with back can enclosure
- Self-contained 1-watt amplifier
- For 24V, self-amplified systems, or as add-on to expand other systems
- 8" main speaker cone with 10 oz. magnet, plus secondary high-frequency cone
- Front-mounted, recessed volume control

CSD1X2, CSD2X2, and ACD2X2 Series Drop-In Ceiling Speakers

All Models Feature:

Finely perforated grille over entire front of speaker • Industrial-grade Steel Construction
Choose Bright White or Off-white Grille Finish • Support Rail Crossbar (included) • Seismic Attachment Points

These ceiling speakers are fast and easy to install, and fit into standard 2 ft. x 2 ft. or 2 ft. x 4 ft. grids.

- 1 Place speaker in ceiling grid.
- 2 Make a simple cut to the ceiling tile (if necessary).
- 3 Lay Tile Support Rail across ceiling grid (if necessary).
- 4 Drop speaker into place.

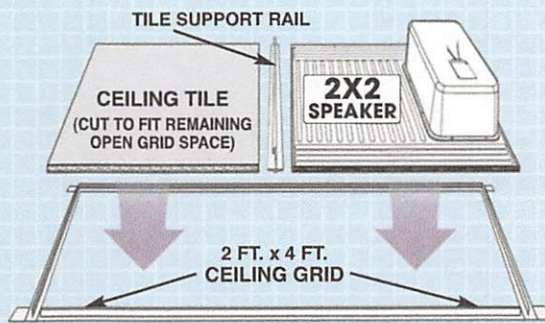
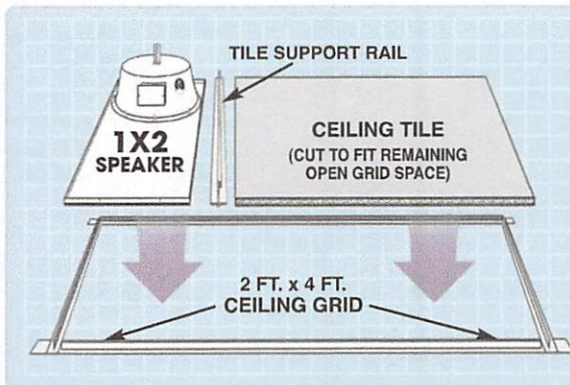
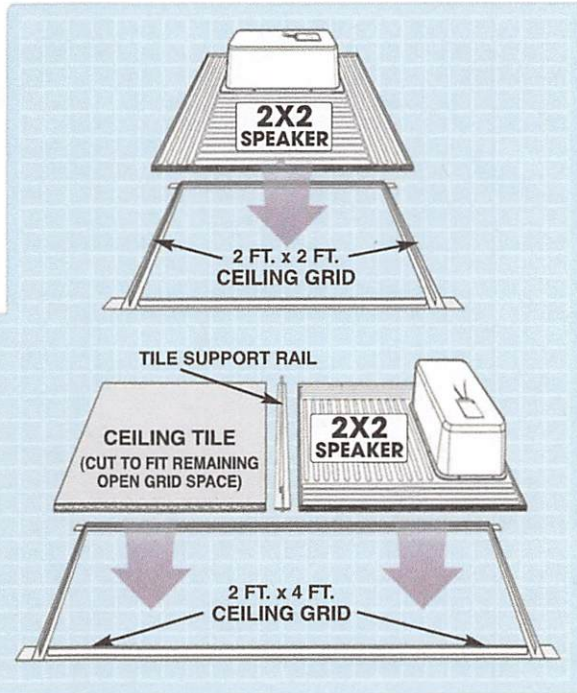

Model	Speaker Size		Grille Color		Impedance			Speaker Back Can	Recessed Volume Control
	1 ft. x 2 ft.	2 ft. x 2 ft.	Off-white	Bright White	70V/25V (4W max.)	8-ohm (15W max.)	24V Self-Amplified (1W max.)		
CSD1X2	●		●		●			●	
CSD1X2U	●			●	●			●	
CSD1X2VR	●		●		●			●	●
CSD1X2VRU	●			●	●			●	●
CSD2X2		●			●			●	
CSD2X2U		●		●	●			●	
CSD2X2VR		●	●		●			●	●
CSD2X2VRU		●		●	●			●	●
CSD2X2L		●	●			●		●	
CSD2X2LU		●		●		●		●	
ACD2X2		●	●				●	●	●
ACD2X2U		●		●			●	●	●

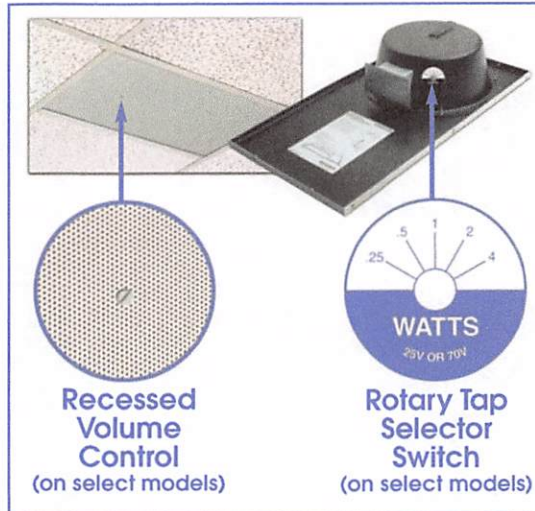

For complete specifications of all models, visit: www.bogen.com



12 Watt Reflex Horn Speaker

for Music & Paging

312 Series

- Reflex horn speaker with good frequency range for music and paging applications in moderately noisy environments.
- Power rating 12 watts, continuous duty.
- Unique mounting base design offers quick and easy mounting and adjustment.
- Two hole patterns allow assembly of base plate to various electrical boxes.
- Strong but lightweight construction of impact & UV resistant ABS with polycarbonate base assembly and stainless steel fasteners.
- Polycarbonate base plate is strong enough to be mounted with stud gun or concrete nails.
- May be recess mounted – hole locations are dimpled on back of flange.
- Attractive tan color.
- 25 or 70.7 volt models are tapped with 5-conductor color coded cable.
- Manufactured in Fourjay's plant under strict quality requirements.

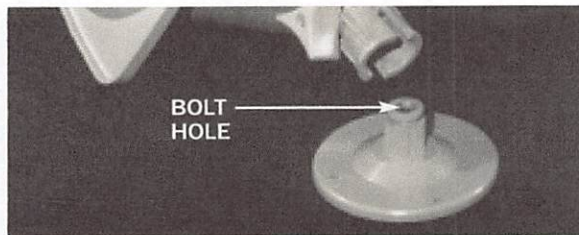

MODEL NO.	RATED INPUT	INPUT TAPS		WT. (lbs.)
		WATTS	OHMS ($\pm 10\%$)	
312-8	8 ohms	12	8	2
312/25-T	25 V line	12,6,3,1	52,104,208,625	2-1/2
312/70-T	70.7 V line	12,6,3,1	415,830,1660,5000	2-1/2

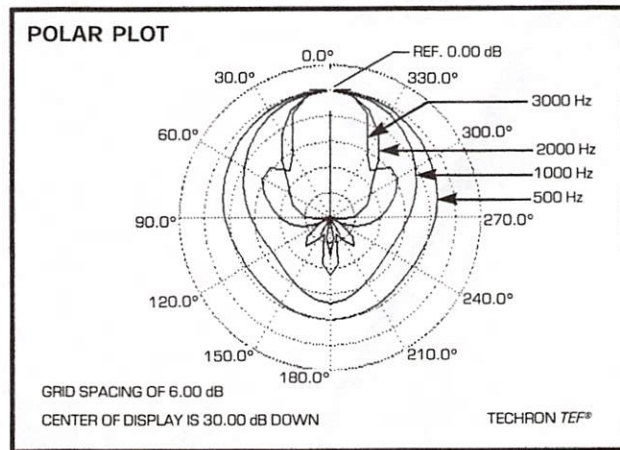
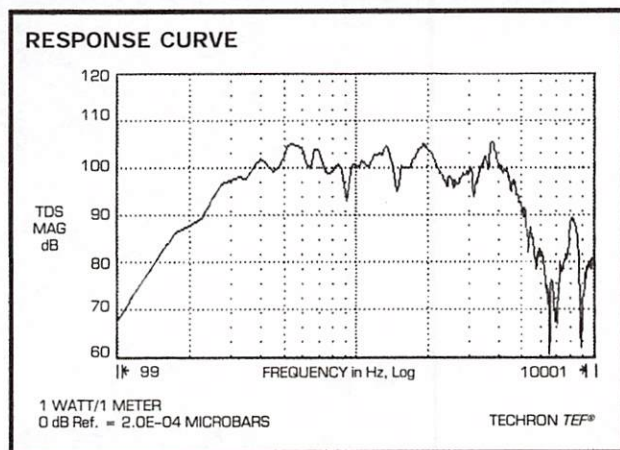

FOURJAY SINCE 1956
INDUSTRIES, INC.

3400 STOP EIGHT ROAD • P.O. BOX 13617 • DAYTON, OH 45413-0617
TELEPHONE (937) 890-6444 • FAX (800) 4J HORNS (454-6767)
WEBSITE: <http://www.fourjay.com> • EMAIL: 4j@fourjay.com

Fourjay Quality—American Made

IN STOCK

IMMEDIATE SHIPMENT

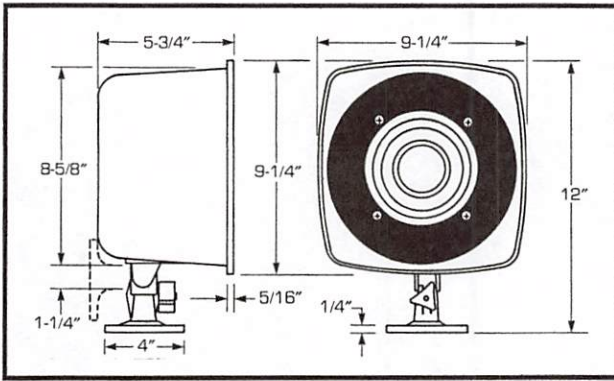

TECHNICAL SPECIFICATIONS

Power Handling: 12 watts continuous duty.

Frequency Range: 230-5000 Hz (± 6 dB)
(On Axis) 140-6200 Hz (± 12 dB)

Sound Pressure Level: (Model 312-8 at 1 meter)

- 1 watt, 500-5000 Hz, averaged; 101 dB
- 12 watts, 500-5000 Hz, averaged; 112 dB

5 CONDUCTOR INPUT CABLE POWER TAP CODE

MODELS	BLK	BRN	GRN	RED	WH
312/25-T 312/70-T	COM	12W	6W	3W	1W

PHYSICAL SPECIFICATIONS

Materials: Impact resistant ABS horn. High stability polycarbonate mounting components. Stainless steel fasteners.

Driver: Cone type, 5-1/4" diameter loudspeaker. Steel parts plated to resist corrosion.

Mounting Provisions: Fully adjustable, 2-axis, positive spline lock mounting assembly. Removable polycarbonate base mounts to electrical boxes. Dimpled hole locators in flange for recessed mounting.

Color: Tan.

Wiring: 2-conductor black jacketed 18-gauge cable on Model 312-8. Color coded 5-conductor 20-gauge black jacketed cable on Model 312/25-T and 312/70-T.

ARCHITECT'S & ENGINEER'S SPECIFICATIONS

The loudspeaker shall be a reflex driver type horn projector of integrated construction, Fourjay Model (312-8, 312/25-T, 312/70-T). It shall be rated 12 watts for voice or music material with an on-axis frequency response of 230 to 5000 Hz (± 6 dB). The sound pressure level shall average 101 dB (1W/1M) for 500 to 5000 Hz.

The horn shall be tan in color and constructed of impact & UV resistant ABS with a matching color base assembly constructed of polycarbonate. All materials shall resist damage from extreme weather exposure and will retain mechanical properties from -20° to $+160^{\circ}$ F.

The mounting Provisions shall be a fully adjustable, 2-axis, positive spline lock assembly with removable base that will mount to many electrical boxes, or recess mounted using horn flange.

MOUNTING METHODS AND ACCESSORIES

KBC123 Kit Beam Clamp Mount	KBJ123 Kit Bar Joist Mount	KTG123 Kit Toggle Bolt Mount	KPM123 Kit Pole Mount
Stud Driver or Concrete Nails	Mounting to Electrical Boxes		



FOURJAY SINCE 1956
INDUSTRIES, INC.

3400 STOP EIGHT ROAD • P.O. BOX 13617 • DAYTON, OH 45413-0617
TELEPHONE (937) 890-6444 • FAX (800) 4J HORNS (454-6767)
WEBSITE: <http://www.fourjay.com> • EMAIL: 4j@fourjay.com

Fourjay Quality—American Made

Washington County Board of Education

Monitoring: Review: Annually	Descriptor Term: Telework During Emergencies	Descriptor Code: 5.1151	Issued Date: 04/09/20
		Rescinds:	Issued:

General

Teleworking is a work arrangement where designated employees are allowed to perform their normal duties and responsibilities through the use of hardware and software at an alternate location from their normal work site.

The Director of Schools may require an employee to telework if the duties and responsibilities of the position are required during times of emergency. An employee's participation in the program will be determined by the length and duration of the emergency and will be both initiated and ended at the discretion of the supervisor and/or the Director of Schools. **Telework outside of times of emergency is not permitted.**

WORK ENVIRONMENT

Employees approved for telework shall maintain a dedicated and safe work environment.

An employee who teleworks shall not allow anyone other than district employees to utilize district provided services or equipment. Employees shall keep remote work and information confidential, in accordance with district policies, procedures, and applicable privacy laws.

Cross References

Emergency Closings 1.8011

Washington County Board of Education

Monitoring: Review: Annually	Descriptor Term: Student Wellness	Descriptor Code: 6.411	Issued Date: 07/01/25
		Rescinds: 6.411	Issued: 09/07/23

The Board recognizes the value of proper nutrition, physical activity, and other health conscious practices and the impact that such practices have on student academic achievement, health, and well being. In order to provide an environment conducive to overall student wellness, this policy shall be followed by all schools in the district.¹

COMMITMENT TO COORDINATED SCHOOL HEALTH

All schools shall implement the CDC's Coordinated School Health approach to managing new and existing wellness related programs and services in schools and the surrounding community based on state law and State Board of Education CSH standards and guidelines. Washington County's Coordinated School Health Coordinator shall be responsible for overseeing compliance with State Board of Education CSH standards and guidelines in the school district.

SCHOOL HEALTH ADVISORY COUNCIL^{2,3}

A school district health advisory council shall be established to serve as a resource to school sites for implementing policies and programs and develop an active working relationship with the county health council. The council shall consist of individuals representing the school and community, including parents, students, teachers, school administrators, health professionals, school food service representatives, and members of the public. The primary responsibilities of the council include but are not limited to:

1. Developing, implementing, monitoring, reviewing, and as necessary, making recommendations as to physical activity and nutrition policies;
2. Ensuring all schools within the district create and implement an action plan related to all School Health Index modules;
3. Ensuring that the results of the action plan are annually reported to the council; and
4. Ensuring that school level results include measures of progress on each indicator of the School Health Index.

The State Board of Education's Coordinated School Health and Physical Activity policies shall be used as guidance by the council to make recommendations. The Board will consider recommendations of the council in making policy changes or revisions.

Additionally, each school will have a Healthy School Team consisting of but not limited to the school nurse, teachers, students, parents, community members, and administrators.² The Team will hold Healthy School Team meetings during the school year to assess needs and oversee planning and implementation of school health efforts. The Director of Schools/designee will ensure compliance with the school wellness policy, to include an assessment of the implementation of the wellness policy and the progress made in attaining the policy goals. The assessment will be made available to the public.

COMMITMENT TO NUTRITION

All schools within the district shall participate in the USDA child nutrition programs, which may include but not be limited to, the National School Lunch Program, the School Breakfast Program, the Summer Food Service Program, and the After School Snack Program.^{4,5,6}

Meals shall be accessible to all students in a non-stigmatizing manner. Students will be given adequate time to enjoy healthy meals and relax in a pleasant environment. Good nutritional habits shall be encouraged. All food including vending machines, fundraising items, and concessions must meet guidelines set forth by the Healthy, Hunger-free Kids Act, 2010, Smart Snacks in Schools.^{4,5,6} The school principal/designee shall be responsible for overseeing the school district's compliance with the State Board of Education rules and regulations for sale of food items in the school district.^{2,5,6}

Fundraising

Food-and beverages sold that can be consumed on campus during the school day must meet or exceed the USDA Smart Snacks guidelines in school nutrition standards. Schools shall follow the limit on days per semester in which non-healthy foods may be used for fundraisers.⁴

DISTRICT GOALS

The district will promote healthy nutrition through various activities, including nutrition related newsletters, informational links on the district website, healthy eating posters and bulletin boards in dining areas, and informational booths at various community functions. Nutrition education will be offered as part of a standards based program designed to provide students with the knowledge and skills needed to promote and protect their health as outlined in the State Board of Education Health Education and Lifetime Wellness Standards. Nutrition education will discourage teachers from using high fat, sugar, and sodium foods as rewards and encourage students to start each day with a healthy breakfast.

COMMITMENT TO PHYSICAL ACTIVITY AND PHYSICAL EDUCATION⁷

The Board recognizes that physical activity is extremely important to the overall health of a child. Schools shall support and promote physical activity. Physical activity may be integrated into any areas of the school program.

Unstructured physical activity periods shall be offered in addition to the school district's physical education program. Elementary school students shall receive a minimum of forty (40) minutes of physical activity each full school day. Middle and high school students shall receive a minimum of ninety (90) minutes of physical activity each full school week.

Physical education classes shall be offered as part of a standards based program designed to provide developmentally appropriate moderate to vigorous physical activity as an integral part of the class. All physical education classes shall comply with the State Board of Education's Physical Education Standards. In addition to the district's physical education program, non-structured physical activity periods shall be offered as required by law.

Schools shall continue to offer after school sports and activities. Physical activity shall not be employed as a form of discipline or punishment during scheduled curricular activities. This policy is not designed to address the use of physical activity as a form of discipline for students choosing to participate in extracurricular activities. The withholding of physical activity or physical education in response to inappropriate behavior such as failure to complete assignments or other negative behavior is not permitted. This does not refer to withholding physical activity, benching a student for a time period, because of inappropriate behavior during physical education class or other organized physical game/activity.

MARKETING OF SMART SNACKS

All food and beverage marketing within school premises, including vending machines, school stores, cafeteria displays, and promotional materials, must exclusively feature items that meet the USDA's Smart Snacks in School nutrition standards. Foods and beverages promoted through marketing materials must be in compliance with these standards, ensuring that only nutritious and healthy choices are encouraged. Food and beverage items that do not meet the Smart Snacks in School guidelines, such as sugary snacks, regular sodas, and high-calorie items, shall not be advertised or promoted through marketing initiatives within the school. Beverage vending machines located on school premises will exclusively offer beverages that meet Smart Snacks requirements. Non-compliant beverages, such as regular sodas and sugary drinks, shall not be available for purchase through school vending machines.

COMMITMENT TO CURRICULUM³

All applicable courses of study should be based on State-approved curriculum standards.

SCHOOL HEALTH INDEX³

All schools within the district shall annually administer a baseline assessment on each of the recommended School Health Index modules. Results shall be submitted to the School Health Advisory Council and reported to the State Department of Education.

RECORD KEEPING COMPLIANCE

The district's Coordinated School Health Coordinator shall ensure that records demonstrating compliance with community involvement requirements are maintained. The Coordinated School Health Coordinator shall additionally document that the school wellness policy and triennial assessments are made available to the public.⁸

Legal References

1. [TCA 49-6-1022](#)
2. [State Board of Education Policy 4.204](#)
3. [State Board of Education Policy 4.206](#)
4. [TRR/MS 0520-01-06](#)
5. [42 USCA § 1758b; TRR/MS 0520-01-06-.04](#)
6. [TRR/MS.0520-01-06](#)
7. [7 CFR § 210; 7 CFR § 220](#)
8. [TCA 49-6-1021; Public Acts of 2025, Chapter No. 306](#)
9. [7 CFR § 210.31\(f\)](#)

Cross References

Student Suicide Prevention 6.415

1st Reading

Washington County Board of Education			
Monitoring: Review: Annually	Descriptor Term: Director of Schools	Descriptor Code: 5.800	Issued Date: 11/20/19
		Rescinds: 5.121	Issued: 05/07/98

The director of schools shall be the chief executive officer of the school system and shall have, under the direction of the board, general supervision of all the public schools, personnel, and departments of the school system. The director of schools is responsible for the management of the schools under the board's policies and is accountable to the board.¹ **The Director of Schools is the only employee directly employed by the Board of Education. All other employees of the district are employed, supervised, and managed under the authority of the Director of Schools.¹**

The Director of Schools is charged by the Board with the responsibility to oversee and manage all personnel matters within the district, consistent with applicable laws, regulations, and Board policies. This includes hiring, assignment, evaluation, discipline, and dismissal of employees, as well as the delegation of such duties as appropriate.²

Legal References

1. [TCA 49-2-301\(a\)](#)
2. [TCA 49-2-301\(e\)](#)

The director of schools, at his/her discretion, may delegate any of his/her duties to other school personnel.

- 3.

1st Reading

Washington County Board of Education			
Monitoring: Review: Annually	Descriptor Term: Tutoring for Pay	Descriptor Code: 5.608	Issued Date: 05/07/98
		Rescinds:	Issued:

Any teacher may enter into an agreement with parents for tutoring children for a fee, but this practice must be limited to those children who the teacher is not currently exercising teaching, administrative, or supervisory responsibility.¹ **No private teaching or tutoring shall be done during the hours of the regular school day.**

Any teacher who enters into a private tutoring agreement with a parent/guardian does so as an independent actor and not as an agent of the school district. The school district shall not be liable for any claims, damages, or liabilities arising from or related to private tutoring services provided by a school employee. The teacher providing such tutoring services shall assume full responsibility and liability, and agrees to indemnify and hold harmless the school district, its board members, administrators, and employees from any and all claims, demands, actions, or causes of action arising out of or in connection with such services.

School facilities may not be used for private profit.²

Legal References

1. TCA 49-5-1003
2. TCA 49-2-405(a)

1st Reading

Washington County Board of Education			
Monitoring: Review: Annually	Descriptor Term: Political Activities	Descriptor Code: 5.606	Issued Date: 01/09/20
		Rescinds: 5.606	Issued: 05/07/98

Employees have a right to express their views on any issue but must in each case make clear that the view expressed is not the official view of the board or school system.

Employees may, on their own time, campaign for or against any candidate or referendum but are prohibited from using system owned property to engage in political activity. District owned property includes, but is not limited to: all buildings, signage, message boards, telephonic equipment, electronic equipment, and email accounts. **District-owned property, including school buildings, district offices, and other facilities, shall not be used as a location for filming or recording content intended for political promotion or solicitation.** Employees shall not use audio or video messages to engage in any political promotion or solicitation during school hours.¹

Legal References

1. TCA 49-6-2009

Cross References

Board-Community Relations 1.500
News Releases, News Conferences & Interviews 1.503
Advertising & Distribution of Materials in Schools 1.806

Washington County Board of Education

Monitoring: Review: Annually	Descriptor Term: Drug & Alcohol Testing for Employees	Descriptor Code: 5.403	Issued Date: 11/05/20
		Rescinds: 5.403	Issued: 02/03/20

REASONABLE SUSPICION DRUG TESTING

If a supervisor observes or receives a report of conduct suggesting a potential violation of Policy 1.804, Alcohol & Drugs in the Workplace, the supervisor shall promptly inform the Director/designee. Upon reasonable suspicion that an employee’s job performance or behavior may be impaired by illegal drugs, including improper use of prescribed drugs, or alcohol, the Director/designee may require the employee to undergo drug or alcohol testing.

An employee who is required to submit to drug or alcohol testing based upon reasonable suspicion and refuses shall be charged with insubordination, and necessary procedures will be taken to terminate the employee in accordance with board policy, and state law, where applicable.

An employee who tests positive on a reasonable suspicion test will be in violation of this policy and subject to termination.

The Director or his/her authorized designee are the only individuals in the district authorized to make the determination that reasonable suspicion or cause exists to order a drug screen and are the only individuals who may order an employee to submit to a drug screen.

Two types of cases for which reasonable suspicion procedures may be invoked are:

1. **Chronic Case:** Deteriorating job performance or changes in personal traits characteristics where the use of alcohol or drugs may be reasonably suspected as the cause.
2. **Acute Case:** Appearing in a specific incident or observation to then be under the present influence of alcohol or drugs, or investigation of an accident where the use of alcohol or drugs is reasonably suspected to be a contributing cause.

Circumstances under which substance screening may be considered, in either the chronic or acute cases, include, but are not limited to, the following:

1. Observed use, possession, or sale of illegal drugs and/or use, possession, sale, or abuse of alcohol and/or the illegal use or sale of prescription drugs.
2. Apparent physical state of impairment of motor functions.

3. Marked changes in personal behavior not attributable to other factors.
4. Employee involvement in or contribution to an accident where the use of alcohol or drugs is reasonably suspected or employee involvement in a pattern of repetitive accidents, whether or not they involve actual or potential injury.
5. Violations of criminal drug law statutes involving the use of illegal drugs, alcohol, or prescription drugs and/or violations of drug statutes.

The circumstances, under which substance screening may be considered, as outlined above, are strictly limited in time and place to employee conduct on duty or during work hours, or on or in Board of Education property, or at school system-approved or school-related functions.

Prior to substance screening, employees must sign an acknowledgment that the summary result will be transmitted to the Medical Review Officer and the Director/designee.

Drug and alcohol screening shall be conducted by Board approved, independent, certified laboratories utilizing recognized techniques and procedures. A breath analysis test will be performed by a certified Breath Alcohol Technician.

TESTING FOR CDL EMPLOYEES

All drivers and applicants for driver positions who are required to hold a Commercial Driver's License (CDL) to perform their job function shall adhere to the requirements of this policy and all procedures relating to this policy.¹

The use, possession, sale, purchase, or transfer of any controlled substances, except medically prescribed drugs on school property, while on school business, or while operating school vehicles and equipment, is prohibited. Drinking alcoholic beverages during working hours, four (4) hours before reporting to work, or having any measurable amount of alcohol in the employee's system during working hours is prohibited, whether on or off school property. Working hours include all breaks. Off-duty use of drugs and alcohol is prohibited to the extent that it affects the driver's attendance or performance and his/her ability to pass required Department of Transportation alcohol and controlled substance tests. Any violation of this policy is grounds for termination and possible legal prosecution.

The use of any prescription drug that could affect the central nervous system or one that would impair reaction time shall be reported to the Director of Schools/designee. Notice shall be given of non-prescription (over-the-counter) drugs being taken on a regular basis. The notice shall include the duration of ingestion and the possible side effects.

Procedures

The execution and enforcement of this policy will follow set procedures to screen bodily fluids, conduct breath testing, and/or search all employees/applicants for alcohol and drug use and those employees suspected of violating this policy who are involved in a reportable accident or who are periodically or randomly selected. The procedures are designed not only to detect violations of this policy but also to ensure fairness to each employee. Disciplinary action will be taken as necessary.

Implementation

The Director of Schools/designee is authorized to implement this policy and procedures for the drug testing program, including a periodic review of the program to address any problems, changes, and/or revisions of it, maintenance of all records required by the federal regulations, and determination upon board approval of how the program will be accomplished, whether in-house, contracted, or by consortium.

Dissemination

The Director of Schools/designee shall be responsible for communicating this policy and the procedures to all employees affected by this policy and shall be accountable for its consistent enforcement.² The Director of Schools/designee is designated to answer questions about this policy, procedures, and all other matters involved in alcohol and controlled substance testing of CDL drivers and the reasonable suspicion testing of all other employees. ~~It is the policy of the Washington County School System to maintain a workplace that is free from the effects of drug and alcohol abuse, subject to the following provisions:~~

- ~~1. It is prohibited for any employee to use or possess illegal controlled substances on or off duty;~~
- ~~2. It is prohibited for any employee to use legal drugs in a manner which might interfere with the employee's performance of duties;~~
- ~~3. Any employee found in violation of these provisions may be subject to disciplinary action;~~
- ~~4. Employees will be subject to testing for alcohol and controlled substances according to the procedures described in this policy.~~
- ~~5. Employees must notify their Department Head/Principal of any criminal drug statute conviction no later than the first work day following the conviction.~~

~~CLASSES OF EMPLOYEES~~

~~This policy applies to all employees and applicants of Washington County Schools. All employees are subject to pre-employment drug testing and reasonable suspicion drug and alcohol testing.~~

~~Commercial drivers license (CDL) holders, as part of their job duties, are also subject to additional drug testing requirements pursuant to a separate policy dictated the U.S. Department of Transportation. CDL holders are also subject to this policy.⁴~~

~~TESTS REQUIRED²~~

Pre-employment

~~All job applicants of Washington County Schools must consent to undergo drug testing at the time of the pre-employment/post-offer physical examination. Tests will be conducted after a provisional offer of employment has been made and before an employee performs a health or safety function for the first time.~~

Post-accident/Serious Incident

~~Alcohol and controlled substance tests will be conducted after accidents involving employees whose performance could have contributed to the accident, which results in (1) a fatality; (2) bodily injury which requires immediate medical treatment away from the scene of the accident, and/or; (3) in the case of a vehicle accident, damage requiring the vehicle to be towed away from the scene of the accident. Tests should be done as soon as practicable after the accident, although there should be no delay in any medical treatment required. Alcohol tests should be completed within two hours of the accident and in no event after eight hours and controlled substance tests will be administered within 32 hours of the accident.~~

~~Employees may be ordered to test any time they use force, which is reasonably calculated to produce death or serious bodily injury. Serious bodily injury is any injury that creates a substantial risk of death; causes permanent disfigurement or results in long-term loss or impairment of any bodily member or organ.~~

Reasonable Suspicion

~~When a supervisor observes and documents appearance, behavior, speech, or body odors of an employee, which are characteristic of the use of alcohol or controlled substances, drug and alcohol tests may be ordered. Observations may include symptoms of chronic use or withdrawal. Supervisors must document these observations on the approved form. The Director of Human Resources or his/her designee will review the documentation and pertinent information ascertains the suspicion. If the Director of Human Resources or his/her designee agrees, he/she will order the employee to submit to a controlled substances and/or alcohol test.~~

~~No employee shall be allowed to drive or perform any health or safety function when suspected of being impaired, until a test report that the employee is medically qualified to work is received.~~

HOW TESTS WILL BE DONE²

Alcohol

~~Alcohol is defined as any food, beverage, mixture or preparation, including any medication, containing ethyl alcohol. Testing for the use of alcohol will be done using evidential breath testing (EBT) devices approved by the federal government. EBT devices determine the concentration of alcohol in the blood alcohol concentration (BAC). If the BAC is less than four-hundredths of one percent (.04%) by weight of alcohol in the blood, the test is considered negative. This is the standard for all employees although a CDL holder is not allowed to drive with a BAC greater than two-hundredths of one percent (.02%). If the BAC is four-hundredths of one percent (.04%) or greater, the test is considered positive and a second test will be conducted immediately after the initial test to confirm the result of the initial test. Washington County Schools reserves the right to order a blood test as additional confirmation in extraordinary situations.~~

Controlled Substances

~~Controlled substance tests will be done by urinalysis and will check for the following drugs:~~

- ~~Acetylmorphine~~
- ~~Amphetamines~~
- ~~MDA~~
- ~~Cocaine~~
- ~~Marijuana (THC metabolite)~~
- ~~Opiates (including heroin and codeine)~~
- ~~Opiates-Semi-Synthetic~~
- ~~Oxycodones~~
- ~~Phencyclidine (PCP)~~

~~Tests may be requested for other substances if there is reason to believe that a test for the substances may be positive. Analysis shall be conducted by a laboratory certified by the U.S. Department of Health and Human Services (DHHS). If a screening test is positive for a controlled substance, a confirmation test is performed using the gas chromatography/mass spectrometry (GC/MS) analysis. The urine sample will be split in case of the possibility of retest. Levels constituting a positive test are established by DHHS. A positive test is considered the same as being under the influence of drugs for the purpose of this policy.~~

~~NOTIFICATION OF RESULTS AND ROLE OF THE MRO~~

~~All controlled substances tests are reviewed and interpreted by a physician designated as the Medical Review Officer (MRO) before they are reported to the employer. If the laboratory reports a confirmed positive result to the MRO, the MRO contacts the employee or applicant to determine if there is an alternative medical explanation for the substances found in the urine specimen.~~

~~If the employee provides appropriate documentation and the MRO determines that it is legitimate medical use of the prohibited substances, the result is reported as negative to the employer although the employee may not be medically qualified to perform normal functions. The Director of Human Resources (or designee) will notify the employee of test results, and if positive, will inform the employee to contact the MRO if the MRO has been unable to contact the employee.~~

~~CONSEQUENCES OF A POSITIVE TEST~~

~~*Refusal to Test*~~

~~Any refusal to submit to a test shall be considered a positive test. Willful refusal to test, or an attempt to tamper with the test, is in violation of this policy and will be considered a positive test. Refusal to submit may include failure to provide an adequate breath or urine sample for testing unless medical reasons are confirmed.~~

~~An employee who tests positive or who refuses to test will be subject to disciplinary action up to and including termination.~~

~~*Removal from Normal Duties*~~

~~Employees who test positive for controlled substances or alcohol, refuse to submit to such tests, or attempt to tamper with the test are in violation of this policy and shall be removed from performing normal duties pending further action. Employees who are ordered to test based on reasonable suspicion~~

~~shall be removed from any duties in which they may pose a possible safety risk until the test results confirm they are medically fit to perform such duties.~~

Removal from Eligibility

~~Employees and applicants who have a confirmed positive pre-employment test result for controlled substances or alcohol or refuse to test will be denied employment and may be considered ineligible for future employment~~

~~Employees who have a confirmed positive result on any test for controlled substances or alcohol shall be subject to further action, which may include rehabilitation and/or disciplinary action up to and including termination. Disciplinary action is at the discretion of the Director of Schools. The Director of Schools may take into account factors such as the circumstances which led to testing, the employee's work history, length of employment, job performance, and past corrective or disciplinary action.~~

~~*Disciplinary action, based on a violation of this substance abuse policy, is not automatically suspended by an employee's participation in an Employee Assistance Program and disciplinary action may be imposed upon the employee if the Director of Schools finds such action warranted*~~

~~RE-TEST PROVISION~~

~~Breath alcohol tests are conducted and confirmed while the employee or applicant is present, eliminating the need for a re-test. For controlled substances, an employee or applicant who has confirmed positive test results may request that the split sample be tested at a separate laboratory with federal certification. Such request must be made within seventy-two (72) hours of learning of the confirmed positive test. Any action required by this policy as the result of a positive test is not stayed pending the result of a test on a split sample. All costs associated with the re-testing of the split sample must be prepaid by the employee, including shipping and handling, transportation, testing and MRO assessment. If the result of the retest is negative, these costs will be reimbursed to the employee.~~

~~RETURN TO WORK AND FOLLOW-UP~~

~~Employees with a confirmed positive test for controlled substances or alcohol may be referred to the Employee Assistance Program in addition to or in lieu of disciplinary action. Employees shall not be allowed to return to normal duties until they submit to a return to work test with confirmed negative results and are recommended by the Employee Assistance or other appropriate counselor to return.~~

~~Employees with a confirmed positive test who are allowed to return to work shall be required to sign a Return to Work Agreement prior to returning to work. For follow-up alcohol tests, any level will constitute a positive, even if it is below the normal cut-off level of a BAC of four-hundredths of one percent (.04%). Failure to comply with the Return to Work Agreement will subject an employee to disciplinary action.~~

~~OPERATING WASHINGTON COUNTY SCHOOL SYSTEM EQUIPMENT~~

~~No employee shall be allowed to operate a school system vehicle following a positive test for a minimum period of ninety (90) calendar days after presenting a negative return-to-work test. The same requirement shall apply to an employee whose license is suspended due to a DUI conviction, even if the employee is granted a restricted license. A Return-to-Work Agreement is also required in such cases. If driving is an essential function of the position, the employee may be demoted until all restrictions are lifted.~~

~~CONFIDENTIALITY~~

~~Washington County Schools, the company contracting to administer the testing program, the testing laboratory, and the Medical Review Officer shall strictly maintain the confidentiality of controlled substances and alcohol testing results and records. These results cannot be released to others without the written consent of the employee. Exceptions to these confidentiality provisions are limited to the decision-maker in litigation or administrative proceedings or officials designated in the federal regulations. Statistical records are maintained for required reports.~~

~~Employees involved in testing and the administration of this policy shall observe strict confidentiality of an employee's test results and treatment. Any employee who violates this requirement for confidentiality will be subject to disciplinary action.~~

~~TRAINING³~~

~~Informational Program - All employees will be made aware of this policy. The policy will be made known to all new employees and the information will be incorporated in new employee orientation.~~

~~Supervisors - Supervisors shall attend a program of training. This program will be designed to teach supervisors how to identify and document substance abuse among employees and to familiarize them with the controlled substances testing program, provisions of this policy, and related laws.~~

~~Program Administrator - the Director of Human Resources serves as the liaison with the company who manages testing and reporting~~

~~CONFLICT WITH OTHER LAWS OR COURT ACTION~~

~~If any provision of this policy or the application thereof, to any person or circumstance is held to be invalid, the invalidation shall not affect any other provisions or the application of this program and to this end the provisions of the program are declared to be severable.~~

~~ADMINISTRATIVE PROCEDURES~~

~~The Director of Schools shall develop administrative procedures in accordance with the *Tennessee Drug Free Workplace Employer's Program Development and Implementation Guide (October 1997)* and state law and regulations.~~

Legal References

1. ~~49 USCA § 5331; Alcohol and Controlled Substances Testing (Omnibus Transportation Employee Testing Act of 1991)~~ Omnibus Transportation Employee Testing Act of 1991, 49 USCA § 5331
2. ~~Drug-Free Workplace Act of 1988~~
3. 49 CFR 382.601

Cross References

Alcohol & Drugs in the Workplace 1.804

Washington County Board of Education

Monitoring: Review: Annually	Descriptor Term: Personnel Health Examinations / Communicable Diseases	Descriptor Code: 5.400	Issued Date: 09/03/20
		Rescinds: 5.400	Issued: 08/13/19

All employees, prior to entering service, shall present a certificate showing a satisfactory health record.¹ Employees shall inform the **Director of Schools** ~~director of schools~~ whenever they contract a contagious or communicable disease.

An employee who has a communicable disease shall not perform his/her duties in any location where such might endanger the health of students. ~~No employee who has any communicable disease shall perform his/her duties in any location where such might endanger the health of school children.~~ The ~~board~~ Board shall require any employee to submit to a physical examination by a physician whenever there is reason to believe that the employee has any communicable disease.²

The Director of Schools shall reassign an employee to alternate duties, place employee on administrative leave with pay, or temporarily remove employee from the school setting who is suspected of having a communicable disease which might endanger the health of students, pending investigation and final disposition of the case before the Board.

To assist the Board in making final disposition of the case, the Director of Schools may refer the case to the County Health Office or other medical experts.

~~The director of schools shall reassign or suspend any employee who is suspected of having a communicable disease which might endanger the health of children, pending investigation and final disposition.~~

~~In the event an employee has been exposed to a communicable disease but is asymptomatic and has not tested positive for the disease, and pursuant to guidance from the Tennessee Department of Health or the local health department, the Washington County Board of Education delegates to the director of schools the discretion to permit the employee to continue working provided that each of the following criteria are met:~~

- ~~● The director determines that the employee performs an essential function in support of critical infrastructure, as those terms are used by state and federal agencies, and that the employee cannot perform those essential functions remotely;~~
- ~~● The employee remains asymptomatic and has not tested positive;~~
- ~~● The employee wears all necessary and appropriate protective equipment, such as, but not limited to, face masks, while on school campus;~~
- ~~● The employee is able to perform his or her duties while maintaining appropriate social distance; and~~
- ~~● The employee chooses to continue working rather than taking leave otherwise available to him or her.~~

~~The director shall exercise this discretion on a case by case basis weighing the nature of the employee's duties, whether those duties are an essential part of the school system's critical infrastructure, and whether any threat posed by the employee's exposure can be mitigated by the use of protective equipment and maintaining distance from other people.~~

~~Before exercising the discretion set forth in this policy, the director shall develop appropriate administrative procedures, incorporating whatever specific terms or conditions the appropriate local, state, or federal authorities may recommend or require. These procedures shall not become effective unless and until they have first been approved by the appropriate public health authority.~~

~~When the director exercises discretion pursuant to this policy, the director's decision shall be final.~~

Legal References

1. ~~TRR/MS-0520-01-03-.08(2)(f)~~ [TCA 49-5-404](#)
- ~~2. TCA 49-2-203(b)(2); TCA 49-5-710(a)(7); TCA 49-5-404~~

Cross References

Section 504 and ADA Grievance Procedures 1.802

Washington County Board of Education

Monitoring: Review: Annually	Descriptor Term: Sick Leave	Descriptor Code: 5.302	Issued Date: 06/29/23
		Rescinds: 5.302	Issued: 02/04/20

PROFESSIONAL PERSONNEL

Professional personnel shall earn one (1) day of sick leave for each month employed during the school year, and these days shall accumulate for an unlimited number of days.¹

~~A teacher shall be allowed to use unearned sick leave up to the amount of days which such teacher may accumulate during the remainder of the school year in which they are employed. Such advance use of sick leave shall be charged to sick leave accumulated in the same school year. Upon termination of the employment of such teacher before such days are earned or at the end of the school year, there shall be deducted from the final salary of such teacher an amount based on their daily rate of pay sufficient to cover the excess sick leave days used by him. If such final salary is insufficient for this purpose, the teacher shall be liable for reimbursement of any amount in excess of their final salary.~~

Sick leave shall be defined as: illness of a teacher from natural causes or accident, quarantine, or illness or death of a member of the immediate family of a teacher, including the teacher's wife or husband, parents, grandparents, children, grandchildren, brothers, sisters, mother-in-law, father-in-law, daughter-in-law, son-in-law, brother-in-law, and sister-in-law.²

A signed statement listing the cause of absence shall be provided by the employee on forms furnished by the Director of Schools and shall promptly be given to the immediate supervisor in support of all claims for sick leave pay. A falsified statement shall be grounds for dismissal. **An employee absent for five (5) consecutive working days shall submit a doctor's statement verifying illness or injury of the employee or immediate family member.**

Frequent use and/or suspected misuse of sick leave by an employee are sufficient grounds for requiring a physician's certificate stating the reason for absence.

Documentation from a physician may be required in support of any claim for sick leave pay.

~~A certificate from the physician on forms furnished by the Board may be required in support of any claim for sick leave pay.³ If there is any reason to doubt the validity of the certification provided, the director of schools may require, at the expense of the Board, an opinion of a second physician.~~

The principal shall notify the Director of Schools' office at once if an employee is sick beyond ~~twenty (20) consecutive instructional days~~ **the limit of his/her sick leave accumulation.** ~~The substitute teacher, at this point, must have a certificate or permit and must be paid according to the state salary scale.~~

Permanent, cumulative sick leave records for each active professional employee shall be kept in the Director of Schools' office.

A teacher, upon employment, may transfer his/her accumulated sick leave from another Tennessee school **system district**, provided that the Director of Schools of the system in which the accumulated leave was held provides notarized verification.³

SUPPORT PERSONNEL

Support personnel shall earn one (1) day of sick leave for each month an employee is employed. Sick leave may not be earned during the employee's initial three (3) month employment which shall serve as a probation period.

At the termination of the employment of any employee, all unused sick leave accumulated by the employee shall be forfeited for purposes of pay but may be used toward retirement under applicable law.

The immediate supervisor may require ~~a physician's certificate~~ **documentation from a physician** stating the reason for absence.

SICK LEAVE BANK (if applicable)

The purpose of the sick leave bank is to provide sick leave to all employees⁴ who have suffered an unplanned personal illness, injury, disability, or quarantine and whose personal sick leave is exhausted.

To form a sick leave bank, a minimum of twenty (20) employees from the school **system district** shall petition the Board for permission to establish a sick leave bank.⁵ Upon approval, sick leave bank trustees shall be appointed and shall operate as the governing body of the sick leave bank and shall enact rules and regulations consistent with state law.⁶ Employees wishing to participate shall initially give a maximum of three (3) days of sick leave. These days are to be deducted from the employee's personal accumulation and donated to the sick leave bank. Donations of sick leave to the bank are nonrefundable and nontransferable.⁷

At any time the number of days in the sick leave bank is less than twenty (20), or one (1) per employee if there are more than twenty (20) members, or at any time deemed advisable, the trustees shall assess each member one (1) or more days of accumulated sick leave. If an employee has no accumulated sick leave at the time of assessment, the first earned days shall be donated as they are accrued by the employee.⁷

An employee who is a member of the sick leave bank may request an allotment of days (for the employee's personal illness or on account of an illness of his/her minor child) in the manner designated by the trustees. The need for these days shall be verified by a statement from a doctor.⁸

By written notice to the trustees, an employee may withdraw from bank participation on June 30th of any year.⁹ Membership withdrawal results in forfeiture of all days contributed.

The sick leave bank shall be operated in accordance with state law.¹⁰

~~MEDICAL INSURANCE WHILE ON UNPAID LEAVE~~

~~If an employee is ineligible for FMLA and has exhausted all accumulated sick leave, the Board portion of medical insurance will be paid for an employee on unpaid leave for a maximum of 90 days. The employee portion must be paid directly to Washington County Schools if the employee is not receiving a paycheck sufficient to cover the premium amount due. If the employee portion is not received by the 30th of each month, insurance will be terminated. After ninety (90) days, the employee will be responsible for the full premium amount, to be paid directly to the state by the employee.~~

 Legal References

1. TCA 49-5-710(a)(1)
2. TRR/MS 0520-01-02-.04(2)
3. TCA 49-5-710(a)(5)
4. TCA 49-5-811
5. TCA 49-5-803
6. TCA 49-5-804; TCA 49-5-805
7. TCA 49-5-807
8. ~~Public Acts of 2023, Chapter No. 151; TCA 49-5-808(j)~~ [TCA 49-5-808\(j\), \(m\)](#)
9. TCA 49-5-806(d)
10. TCA 49-5-801 *et seq.*

 Cross References

Workers' Compensation 3.602
 Orientation and Probation 5.107
 Short Term Leaves of Absence 5.300
 Family and Medical Leave 5.305
 Physical Assault Leave 5.307

Washington County Board of Education

Monitoring: Review: Annually	Descriptor Term: Separation Practices for Non-Certified Employees	Descriptor Code: 5.202	Issued Date: 06/25/19
		Rescinds: 5.2031	Issued: 01/03/13

ALLEGATIONS REQUIRING TEMPORARY REMOVAL FROM DUTY

If an investigation of an employee's conduct is required, the Director of Schools shall determine whether to temporarily modify the employee's work status based on concerns for safety or to minimize disruption to the educational environment. This may include, but is not limited to:

- Reassignment to alternate duties;
- Placement on administrative leave with pay; or
- Temporary removal from the school setting.

Such action shall not be considered disciplinary in nature but rather a precautionary measure until a determination can be made regarding an appropriate return to duties, or the imposition of disciplinary action, which could include suspension without pay.

SUSPENSION

A Director of Schools/designee ~~director of schools or his/her designee~~ may suspend an employee at any time when deemed necessary.¹

Under no circumstances shall a Director of Schools ~~director of schools~~ suspend an employee with pay if a Department of Children's services or criminal investigation is pending. If reinstated, the employee shall be paid full salary for the period of suspension, unless suspension without pay is deemed to be an appropriate penalty.

DISMISSAL

All non-certified (classified) employees are employed at the will of the Director of Schools ~~director~~. The Director of Schools ~~director of schools~~ may dismiss any non-certified employee during the year for any lawful reason.

RESIGNATION

Support personnel shall give the immediate supervisor written notice of resignation ~~at least two (2) weeks (ten (10) working days)~~ ten (10) working days in advance of the effective date of voluntary

termination. The ten (10) working days may be waived by the Director of Schools ~~director of schools~~ for justifiable reason.

The immediate supervisor shall forward copies the day received to the Director of Schools' ~~director of schools'~~ office. The payroll office will prepare final payment for the next appropriate scheduled pay day.

RETIREMENT

Retirement shall mean a termination of services under conditions which will allow the employee to draw benefits from retirement plans and/or social security benefits. Employees eligible for retirement benefits may elect to retire at any age according to the provisions of the retirement system.

Central office personnel shall assist employees in securing retirement benefits; however, it shall be the responsibility of the retiring employee to obtain verification of eligibility in writing from the Tennessee Consolidated Retirement System (TCRS) ~~TCRS~~ to the central office. It shall be the responsibility of the retiring employee to file for eligible benefits. Employees who retire under TCRS may be employed up to one hundred twenty (120) days per year without loss of retirement benefits.²

Legal References

1. [TCA 49-2-301\(b\)\(1\)\(EE\), \(FF\)](#)
2. [TCA 8-36-805](#)

Cross References

Recommendations and File Transfers 5.203

Washington County Board of Education			
Monitoring: Review: Annually	Descriptor Term: Separation Practices for Non-Tenured Teachers	Descriptor Code: 5.201	Issued Date: 06/30/22
		Rescinds: 5.201	Issued: 08/05/21

ALLEGATIONS REQUIRING TEMPORARY REMOVAL FROM DUTY

If an investigation of an employee’s conduct is required, the Director of Schools shall determine whether to temporarily modify the employee’s work status based on concerns for safety or to minimize disruption to the educational environment. This may include, but is not limited to:

- Reassignment to alternate duties;
- Placement on administrative leave with pay; or
- Temporary removal from the school setting.

Such action shall not be considered disciplinary in nature but rather a precautionary measure until a determination can be made regarding an appropriate return to duties, or the imposition of disciplinary action, which could include suspension without pay.

SUSPENSION PENDING AN INVESTIGATION¹

The Director of Schools may suspend a teacher at any time that may seem necessary, pending investigation, or final disposition of a case before the Board or an appeal. If the matter under investigation is not the subject of an ongoing criminal investigation or a Department of Children's Services investigation, and if no charges for dismissal have been made, a suspension pending investigation shall not exceed ninety (90) days in duration. Under no circumstances shall the Director of Schools suspend a non-tenured teacher with pay **if there is a pending investigation**. If vindicated or reinstated, the non-tenured teacher shall be paid full salary for the period of suspension.

SUSPENSION OF THREE DAYS OR LESS²

The Director of Schools/designee may suspend a teacher for incompetence, inefficiency, neglect of duty, unprofessional conduct, and insubordination. Before a teacher is suspended, he/she shall be: (1) provided with written notice, including the reasons for the suspension along with an explanation of the evidence; (2) given an opportunity to respond to the Director of Schools at a recorded conference, if requested within five (5) days; and (3) given a written decision of the suspension within ten (10) days. Both parties may be represented by counsel at the conference, which shall be recorded.

Under no circumstances shall the Director of Schools suspend a non-tenured teacher with pay. If reinstated, the non-tenured teacher shall be paid full salary for the period of suspension unless suspension without pay is deemed to be an appropriate penalty.

DISMISSAL OR SUSPENSION GREATER THAN THREE DAYS²

The Director of Schools may dismiss or suspend for more than three (3) days any non-tenured teacher during the contract year for incompetence, inefficiency, insubordination, improper conduct, or neglect of duty after giving the non-tenured teacher, in writing, due notice of the charges.

The Director of Schools shall give the non-tenured teacher an opportunity for a full and complete hearing before an impartial hearing officer.

The Board will appoint an impartial hearing officer to conduct such hearings. The hearing officer will hear the case, and the teacher shall have the right to:

1. Be represented by counsel;
2. Call and subpoena witnesses;
3. Examine all witnesses; and
4. Require that all testimony be given under oath.

Factual findings and decisions in all dismissal cases shall be reduced to written form and delivered to the affected teacher within ten (10) working days following the close of the hearing. The teacher may appeal the decision to the Board within ten (10) working days of the hearing officer rendering the written decision to the teacher. Written notice of appeal to the Board shall be given to the Director of Schools. Within twenty (20) working days of receipt of notice, the Director of Schools shall prepare a copy of the proceedings, including all transcripts and evidence, documentary or otherwise, and provide a copy to the Board.

The Director of Schools shall also have the right to appeal any adverse ruling by the hearing officer in the same manner as the non-tenured teacher.

The Board shall hear the appeal. No new evidence shall be introduced. The non-tenured teacher may appear in person or be represented by counsel and argue why the decision should be modified or reversed. The Board shall take one of the following actions:

1. Sustain the decision;
2. Send the record back if additional evidence is necessary; or
3. Revise the penalty or reverse the decision.

Before any decision to dismiss is made, a majority of the membership of the Board shall concur in sustaining the charges. The Board shall render a decision on the appeal within ten (10) working days after the conclusion of the hearing.

Within twenty (20) working days after receipt of notice of the decision of the Board, either party may appeal to the chancery court in the county where the school district is located. The Board shall provide the entire record of the hearing to the court.

NONRENEWAL

Non-tenured teachers are subject to the same rules and regulations and are entitled to the privileges of employment enjoyed by tenured teachers except that they have no claim upon continuing employment or tenure protections.

The principal is responsible for discussing deficiencies as part of the evaluation process with the non-tenured teacher and providing assistance for overcoming these deficiencies.

The Director of Schools is under no obligation to re-employ non-tenured teachers at the end of their contract period. If the Director of Schools determines not to renew the contract of a non-tenured teacher, the following action shall be taken:

1. The Board shall be notified at the next regular board meeting; and
2. Written notice of non-renewal shall be sent to the teacher by certified mail, overnight carrier, or by email within five (5) business days following the last instructional day for the school year.³ If the reason for nonrenewal is due only to a loss of funding for the position, then the notice shall include a statement listing it as the cause for nonrenewal.⁴

RESIGNATION

A teacher shall give the Director of Schools notice of resignation at least thirty (30) days before the effective date of the resignation.⁵ The Board may waive the thirty (30) days notice requirement and permit a teacher to resign in good standing.

The conditions under which it is permissible to break a contract with the Board are as follows:⁶

1. The incapacity on the part of the teacher to perform the contract as evidenced by the certified statement of a physician approved by the Board; or
2. The release by the Board of the teacher from the contract which the teacher has entered into with the Board.

Any teacher on leave shall notify the Director of Schools in writing at least thirty (30) days prior to the date of return if the teacher does not intend to return to the position from which he/she has taken leave. Failure to render such notice may be considered a breach of contract.⁷

Upon a breach of contract, the Board, upon a motion recorded in its minutes, may file a complaint with the State Board of Education and request the suspension of a teacher's license. After the State Board of Education has provided the teacher an opportunity for defense during a hearing, the State Board of Education may suspend the license for no less than thirty (30) days and no more than three hundred sixty-five (365) days.⁸

RETIREMENT

Retirement is a termination of services under conditions which will allow the teacher to draw benefits from retirement plans and/or Social Security benefits.

Teachers eligible for retirement benefits may elect to retire at any age according to the provisions of the retirement system. Central office personnel shall assist teachers in securing retirement benefits; however, it shall be the responsibility of the retiring teacher to provide verification of eligibility in writing from the Tennessee Consolidated Retirement System (TCRS) to the central office. It shall be the responsibility of the retiring teacher to file for benefits.

(Note: Nonrenewal of non-tenured teachers after the contract year is not suspension or dismissal and does NOT follow the suspension/dismissal guidelines outlined in this policy. Rather, nonrenewal of non-tenured teachers after the contract year follows the nonrenewal guidelines outlined in this policy.)

Legal References

1. TCA 49-5-511(a)(3)
2. TCA 49-2-301(b)(1)(EE); TCA 49-5-512
3. TCA 49-5-409
4. ~~Public Acts of 2022, Chapter No. 678~~ [TCA 49-5-409\(b\)\(2\)](#)
5. TCA 49-5-508
6. TCA 49-5-411(a)
7. TCA 49-5-706
8. TCA 49-5-411(b)

Cross References

Public Hearings 1.401
Teacher Tenure 5.117
Recommendations and File Transfers 5.203

Washington County Board of Education			
Monitoring: Review: Annually	Descriptor Term: Separation Practices for Tenured Teachers	Descriptor Code: 5.200	Issued Date: 03/02/23
		Rescinds: 5.200	Issued: 06/30/22

ALLEGATIONS REQUIRING TEMPORARY REMOVAL FROM DUTY

If an investigation of an employee’s conduct is required, the Director of Schools shall determine whether to temporarily modify the employee’s work status based on concerns for safety or to minimize disruption to the educational environment. This may include, but is not limited to:

- Reassignment to alternate duties;
- Placement on administrative leave with pay; or
- Temporary removal from the school setting.

Such action shall not be considered disciplinary in nature but rather a precautionary measure until a determination can be made regarding an appropriate return to duties, or the imposition of disciplinary action, which could include suspension without pay.

SUSPENSION PENDING AN INVESTIGATION¹

The Director of Schools may suspend a teacher at any time that may seem necessary, pending investigation, or final disposition of a case before the Board or an appeal. If the matter under investigation is not the subject of an ongoing criminal investigation or a Department of Children's Services investigation, and if no charges for dismissal have been made, a suspension pending investigation shall not exceed ninety (90) days in duration. Under no circumstances shall the Director of Schools suspend a teacher with pay **if there is a pending investigation**. If vindicated or reinstated, the teacher shall be paid full salary for the period of suspension.

SUSPENSION OF THREE DAYS OR LESS^{2,3}

The Director of Schools/designee may suspend a teacher for incompetence, inefficiency, neglect of duty, unprofessional conduct, and insubordination. Before a teacher is suspended, he/she shall be: (1) provided with written notice, including the reasons for the suspension along with an explanation of the evidence; (2) given an opportunity to respond to the Director of Schools at a conference, if requested within five (5) days; and (3) given a written decision of the suspension within ten (10) days. Both parties may be represented by counsel at the conference, which shall be recorded.

Under no circumstances shall a Director of Schools suspend a tenured teacher with pay. If reinstated, the tenured teacher shall be paid full salary for the period of suspension unless suspension without pay is deemed to be an appropriate penalty.

DISMISSAL OR SUSPENSION GREATER THAN THREE DAYS⁴

No teacher shall be dismissed or suspended except as provided in this part.

The causes for which a teacher may be dismissed or suspended are: incompetence, inefficiency, neglect of duty, unprofessional conduct, and insubordination, as defined in 49-5-501.

A director of schools may suspend a teacher at any time that may seem necessary, pending investigation or final disposition of a case before the board or an appeal. If the matter under investigation is not the subject of an ongoing criminal investigation or a department of children's services investigation, and if no charges have been made pursuant to subdivision (a)(4), a suspension pending investigation shall not exceed ninety (90) days in duration. If vindicated or reinstated, the teacher shall be paid the full salary for the period during which the teacher was suspended.

When a tenured teacher is charged with offenses that may justify dismissal or a suspension greater than three (3) days, the charges shall be made in writing, specifically stating the offenses that are charged, and shall be signed by the party or parties making the charges.

If, in the opinion of the Board, the charges are of such nature as to warrant the dismissal or a suspension greater than three (3) days of the teacher, the Director of Schools shall give the teacher a written notice of this decision, a copy of the charges against the teacher, and a copy of a form provided by the Commissioner of Education advising the teacher of his/her legal duties, rights, and recourse.

A tenured teacher who has been given notice of charges against him/her may within thirty (30) days after receipt of notice give written notice to the Director of Schools of his/her request for a hearing.

The Director of Schools shall, within five (5) days after receipt of request, assign a hearing officer from the list maintained by the Board.

The Board shall maintain a list of qualified individuals who have indicated a willingness to act as impartial hearing officers as defined under Tennessee law.

The hearing officer shall notify the parties, or their attorney, of the officer's assignment and direct the parties or the attorneys for the parties, or both, to appear before the hearing officer for simplification of issues and the scheduling of the hearing. That hearing shall be set no later than thirty (30) days following receipt of the initial request for a hearing. In the discretion of the hearing officer, all or part of any prehearing conference may be conducted by telephone if each participant has an opportunity to participate, be heard, and to address proof and evidentiary concerns. The hearing officer is empowered to issue appropriate orders and to regulate the conduct of the proceedings.

Either party may appeal to the Board an adverse ruling by giving written notice of appeal within ten (10) working days of the hearing officer's delivery of the hearing officer's written findings and conclusions. The Director of Schools shall prepare a copy of the proceedings, including all transcripts

and evidence, documentary or otherwise, and transmit the same to the Board within twenty (20) working days of the receipt of the notice of appeal.

The Board shall hear the appeal on the record, and no new evidence may be submitted by either party. The appealing party may appear before the Board to argue why the adverse ruling should be overturned. In no event should such argument last more than fifteen (15) minutes unless the Board votes to extend additional time. At the conclusion of the hearing, any member of the Board may vote to sustain the decision of the hearing officer, send the record back for additional evidence, revise the penalty, or reverse the decision. The Board shall render its decision within ten (10) working days after the conclusion of the hearing. In the event that the decision of the Board is appealed to the chancery court, the Board shall transmit the entire record prepared by the Director of Schools and reviewed by the Board to the chancery court for its review.

RESIGNATION

A teacher shall give the Director of Schools notice of resignation at least thirty (30) days before the effective date of the resignation. A teacher who fails to give such notice, in the absence of justifiable extenuating circumstances, shall forfeit all tenure status. The Board may waive the thirty (30) days' notice requirement and permit a teacher to resign in good standing.⁵

The conditions under which it is permissible to break a contract with the Board are as follows:⁶

1. The incapacity on the part of the teacher to perform the contract as evidenced by the certified statement of a physician approved by the Board; or
2. The release by the Board of the teacher from the contract that the teacher has entered into with the Board.

Any teacher on leave shall notify the Director of Schools in writing at least thirty (30) days prior to the date of return if the teacher does not intend to return to the position from which he/she has taken leave. Failure to render such notice may be considered a breach of contract.⁷

Upon a breach of contract, the Board, upon a motion recorded in its minutes, may file a complaint with the State Board of Education and request the suspension of a teacher's license. After the State Board of Education has provided the teacher an opportunity for defense during a hearing, the State Board of Education may suspend the license for no less than thirty (30) days and no more than three hundred sixty-five (365) days.⁸

RETIREMENT

Retirement is a termination of services under conditions that will allow the teacher to draw benefits from retirement plans and/or Social Security benefits. Teachers eligible for retirement benefits may elect to retire at any age according to the provisions of the retirement system.

Central office personnel shall assist teachers in securing retirement benefits; however, it shall be the responsibility of the retiring teacher to provide verification of eligibility in writing from the Tennessee Consolidated Retirement System (TCRS) to the central office. It shall be the responsibility of the retiring teacher to file for benefits.

Legal References

1. TCA 49-5-511(a)(3)
2. TCA 49-2-301(b)(1)(EE), TCA 49-5-512(d)
3. TCA 49-5-511(a)(2)
4. TCA 49-5-511—513
5. TCA 49-5-508(a)
6. TCA 49-5-508(c)
7. TCA 49-5-706
8. TCA 49-5-411(b)

Cross References

Public Hearings 1.401
Teacher Tenure 5.117
Recommendations and File Transfers 5.203

Washington County Board of Education

Monitoring: Review: Annually	Descriptor Term: Personnel Records	Descriptor Code: 5.114	Issued Date: 06/25/19
		Rescinds: 5.117	Issued: 08/07/03

The ~~director of schools or his/her designee(s)~~ **Director of Schools/designee(s)** shall be authorized to maintain personnel records and to permit inspection of the same, except for matters deemed confidential by law. The following personnel records shall be maintained for all employees as appropriate:

1. Employee applications and contracts;
2. Professional certificates and other documents required by state and federal laws and regulations;¹
3. Evaluations;
4. Cumulative information files; and
5. **INS Form I-9²; and**
6. **Disciplinary action, as appropriate and any response from the employee.**

The following guidelines shall be followed:

1. Information contained in personnel records shall be limited to job-related matters;
2. The ~~director of schools~~ **Director of Schools** shall be responsible for notifying all employees of the types of records kept and uses made of such records;
3. Employees shall be granted an opportunity to respond in writing to material placed in records;
4. Employee records are public records, except for matters deemed confidential by law, and shall be open for inspection during regular business hours;³
5. In accordance with federal law, the district shall release information regarding the professional qualifications and degrees of teachers and the qualifications of paraprofessionals to ~~parents~~ **parent(s)/guardian(s)** upon request for any teacher or paraprofessional who is employed by a school receiving Title I funds and who provides instruction to their child at that school;⁴
6. Members of the public may not obtain the home telephone number, personal cell phone number, bank account information, social security number, residential street address, driver license information (except where driving or operating a vehicle is considered to be a part of the employee's duties), or the results of individual teacher evaluations of an employee or of the immediate family members or household members of an employee, unless release of this

information is expressly authorized by the employee;⁵

7. A record of the person inspecting and the date of inspection shall be recorded and notification given to the employee; and
8. Copies of records may be made under rules determined by the **Director of Schools** ~~director of schools~~.⁶

Legal References

1. TCA 49-2-301(b)(1)(M)
2. Immigration Reform and Control Act of 1986, Pub. L. No. 99-603, 100 Stat. 3359
3. TCA 10-7-503, 504
4. ~~20 USCA § 6311(g)(2)~~ 20 USCA § 6312(e)(1)
5. TCA 10-7-504(f)(1); TCA 10-7-504(a)(23)
6. ~~TCA 10-7-506; TCA 49-2-301(b)(1)(CC); TCA 8-50-108~~ TCA 10-7-506; TCA 49-2-301(b)(1)(AA)

Cross References

~~School District Records 1.607~~ Teacher Effect Data 5.1141

1st Reading

Washington County Board of Education			
Monitoring: Review: Annually	Descriptor Term: Field Trips / Excursions / Competitions	Descriptor Code: 4.302	Issued Date: 10/27/20
		Rescinds: 4.302	Issued: 11/08/18

The board encourages field trips and excursions when the experiences are an integral part of the school curriculum and contribute to the board's desired educational goals.

The director of schools shall develop forms and procedures for submitting, reviewing, and approving requests for field trips. **Any request for a field trip, excursion, or competition which requires students to travel out of state or stay overnight requires prior board approval.**

The following guidelines shall be followed in planning and conducting field trips and excursions:

1. Any teacher or principal desiring to take a group of students away from the school on an education field trip requiring transportation must obtain advanced approval of the director. Field trips in the immediate vicinity of the school and not requiring transportation may be approved by the principal;
2. The trip must have a definite purpose and reflect careful planning. Students should be prepared by general class discussion and/or research;
3. If bus transportation is required, the principal or their designee shall make the necessary arrangements. A fee will be charged to the school for mileage when school system buses are used;
4. Signed parental permission forms must be obtained for every student make an off-campus trip beyond the immediate vicinity of the school. The principal shall ensure that these forms are kept on file for the remainder of the school year. The form for parental permission must include: purpose, date, time of departure & return, travel plans, destination, number of chaperons, personal expense involved, rules of conduct and penalties for violation, and other facts necessary for parents to be fully informed. This information is to be completed by the school before the form is signed by the parents;
5. Overnight educational trips and chaperones must be approved by the director of schools in advance. These groups must be accompanied by at least one regular staff member and others from the school who are appropriate for adequate supervision and shall be responsible for student conduct while away. There must be at least one female and one male chaperon if the trip is for a mixed group;
6. Students shall not be penalized for participating in approved school-sponsored trips and activities. Teachers shall permit students to make up class assignments missed because of a trip or activity;
7. All accidents that occur on a school-sponsored trip must be reported by the teacher to the principal immediately upon returning to school. Serious accidents involving personal injury must be reported to the principal and/or director of schools. An emergency shall be dealt with promptly by the teacher or other members of the school staff by taking appropriate action,

including sending the student to the hospital or summoning medical aid or ambulance. In cases where it is necessary to send the student to the hospital, reasonable effort must be made to notify the parents;

8. Any school-sponsored trip not meeting the “educationally beneficial” criteria as defined in this section must have prior approval of the director of schools or their designee.
9. Any school-sponsored trip which is out of country, both out-of-state and overnight must have prior approval by the Board; and
10. Students who are members of the above group who do not go on the field trip are required to attend regular classes.

Any trip for which a fee is charged as defined by state board policy is prohibited.¹

INDEPENDENTLY PLANNED TRIPS

Trips privately planned by school district employees, acting outside the scope of their employment, are not authorized by the school district.

These trips are not approved by the Board and are not considered a part of the curriculum. Total responsibility for privately planned trips rests with the chaperone(s) as well as with the parent(s)/guardian(s) of the students participating in the trip. The following restrictions shall apply:

1. Board funds or resources shall not be used;
2. School district materials shall not be used;
3. The Board shall not assume any liability;
4. Employees are not authorized to act on behalf of the school district;
5. Recruitment efforts made by an employee shall not occur during the instructional school day;
6. Employees are not authorized to recruit students in any privately planned trip except to the extent that the school also permits third party vendors to recruit for such trips; and
7. Absences caused by participation in privately planned trips shall be considered unexcused.

The Washington County Board of Education cautions any employee organizing a privately planned trip regarding an educator’s professional duties toward the students of the Washington County Schools, including the obligation not to use relationships with students for personal financial gain.

Legal Reference

1. TRR/MS 0520-01-03(3)(a)

Cross References

Special Use of School Vehicles 3.402
 Extracurricular Activities 4.300
 Attendance 6.200

Washington County Board of Education

Monitoring: Review: Annually	Descriptor Term: Revenues	Descriptor Code: 2.400	Issued Date: 04/11/19
		Rescinds: 2.400	Issued: 05/04/18

General

Any money collected by any school shall be documented by a written receipt.

The schools may receive funds collected from activities and for events held at or in connection with the school, including contracts with other schools for interschool events. To be included in this accounting are all monies collected from lunch rooms, athletics, entertainments, school clubs, fees, concessions, and all fundraising activities. Each principal shall determine the reconciliation method to be used for all events which require a ticket.¹

The purchase of items intended for resale for profit through the schools shall be subject to sales tax based on the purchase price to the vendor providing the service or item. Resale items not intended to generate a profit will follow the same approval process as fundraisers.²

FEES

School fees are to be kept to a minimum and may be expended only for the purposes for which they were collected. The school shall not require any student to pay a fee to the school for any purpose, except as authorized by the board. No fees shall be required of any student as a condition to attend the school or use its equipment.³ School fees shall be waived for students who receive free or reduced-price lunches.⁴ No student will be penalized for nonpayment of any school fee.

EXTENDED SCHOOL PROGRAM

Extended school funds shall be collected at the individual schools and receipted and deposited in the school bank account. The principal shall report the collections and pay the board by school check.⁵

FINES

A student will be held responsible for the cost of replacing any materials or property which the student loses or damages,⁶ including textbooks, library books, equipment, and buildings. All money collected as fines shall be placed in the system-wide school fund.

TUITION INCOME

Tuition collected from nonresident students shall be placed in the system-wide school fund.

RENTAL INCOME

The principal will collect and remit to the central office all money received for use of a particular school facility or other school property.

GRANTS

Grants for educational purposes made available by the state and/or federal government may be sought by the school system but only when the conditions of their availability are in harmony with the purposes and policies of the board and the laws of the state and county. Principals may apply for and receive grants, but funds must be recorded in a separate restricted fund account.⁷

COLLECTION OF FUNDS THROUGH ONLINE PAYMENT⁶

Approved district staff may utilize vendors approved through the CFO's office with the Director of School's approval for electronic transactions. The Director of Schools/designee shall determine when this type of transaction may be utilized on a case-by-case basis. At the individual school level, the principal shall oversee the collection of funds and submit a plan that includes the following:

1. Adequate supporting documentation for the electronic collection method including a plan to provide a total daily receipt summary;
2. Methods of providing receipts to payers;
3. Information on maintaining and inspecting any voided receipts; and
4. How daily electronic collections shall be reconciled with the total daily receipt summary and who will be assigned to complete this task.

Processing fees for these transactions shall not be charged on the school side.

The Director of School/designee shall establish adequate internal controls to ensure compliance with the *Tennessee Internal School Funds Manual*.

ROUNDING IN CASH TRANSACTIONS

Due to the discontinuance of the penny, rounding procedures shall be utilized in cash transactions. This applies to collections of all cash funds received by the district.

Cash transactions shall be rounded to the nearest \$0.05. The following rounding method shall be utilized:

- Amounts ending in \$0.01 or \$0.02 shall be rounded down
- Amounts ending in \$0.03 or \$0.04 shall be rounded up
- Amounts ending in \$0.06 or \$0.07 shall be rounded down

- Amounts ending in \$0.08 or \$0.09 shall be rounded up

The Director of Schools/designee shall monitor implementation to ensure compliance with accounting standards and state law.

Legal References

1. [TCA 49-2-110\(a\); *Internal School Funds Manual, Section 5-4*](#)
2. [TCA 49-6-3001\(a\); TCA 49-2-110\(c\)](#)
3. [TCA 49-2-114](#)
4. [Internal School Funds Manual, Section 4-32, 4-33](#)
5. [TCA 37-10-101, 102](#)
6. [Internal School Funds Manual, Section 5-8](#)

Cross References

Fundraising Activities 2.601
Student Activity Funds Management 2.900
Food Service Management 3.500
Textbooks and Instructional Materials 4.400
Compensation Guides & Contracts 5.110
Attendance of Non-Resident Students 6.204
Student Fees and Fines 6.709

Washington County Board of Education

Monitoring: Review: Annually	Descriptor Term: Alcohol & Drugs in the Workplace	Descriptor Code: 1.804	Issued Date: 08/13/19
		Rescinds: 1.804	Issued: 04/11/19

General

Any employee who violates the terms of this policy shall be subject to disciplinary action, including but not limited to, suspension, dismissal, and/or referral for prosecution.

The Director of Schools shall be responsible for providing a copy of this policy to all school district employees.

DEFINITIONS

“Workplace” shall include any school building or any school premise; any school-owned or any other school-approved vehicle used to transport students to and from school or school activities; and off-school property during any school-sponsored or school approved activity, event, or function.

“Illegal drugs” shall include any narcotic drug, hallucinogenic drug, amphetamine, barbiturate, marijuana, or any other controlled substance as defined by federal law.²

“Unauthorized drugs” shall include, but are not limited to, inhalants; any designer, synthetic, derivative, analogous, or "look-alike" substances that are manufactured, designed, or intended to resemble and/or mimic the effects of illegal drugs; any legally prescribed drugs being used in a manner for which they were not intended or prescribed including, but not limited to, the use of prescription drugs prescribed for another individual; and any lawful substances that could result in impairment of physical or mental capacity that is threatening to the health or safety of the employee or others.³

“Alcohol” shall include, but is not limited to, spirits, liquor, wine, beer, and any liquid containing alcohol as defined by state and federal law.⁴

ALCOHOL & DRUG-FREE WORKPLACE

No employee while on or in the workplace shall unlawfully manufacture, distribute, dispense, possess, use, or be under the influence of any illegal or unauthorized drugs¹ or any alcohol.⁵

PHYSICAL EXAMINATION/SCREENING BASED UPON REASONABLE SUSPICION

Whenever the Director, or his/her authorized designee reasonably suspects that an employee’s work performance or on-the-job behavior may have been affected in any way by illegal drugs or alcohol or that an employee has otherwise violated this policy, Alcohol & Drugs in the workplace, the employee

may be required to submit a breath and/or urine sample for drug and alcohol testing as detailed in Policy 5.403 Drug & Alcohol Testing for Employees.

Legal References

1. [Drug Free Workplace Act of 1988, 41 USCA § 8103; 34 CFR §§ 84.205 – 84.215](#)
2. [21 USCA § 812](#)
3. [TCA 49-5-1003\(b\)\(16\), \(17\), \(18\)](#)
4. [TCA 57-4-102; 26 USCA § 5002](#)
5. [TCA 39-17-715](#)

Cross References

Supervision 5.108
Drug & Alcohol Testing for Employees 5.403
Drug-Free Schools 6.307

Washington County Department of Education
School Educational **OVERNIGHT** Trip Authorization*

RECEIVED
5/7/26
Jm

Date of Request 5/6/26 School Sulphur Springs Trip Date June 7-10
Estimated time of departure 12 pm June 7 and return 6 pm June 10 total time away 4 days
Destination (include location) Varsity Dance Camp (UDA) at Double Tree Park Vista Resort
Teacher Sandra Hughes Class _____ Grade 6-8 Bathtubburg, TN

Chaperones Ronice Albert Number of Students Involved 6
Sandra Hughes Estimated Total Miles (both ways) of Trip 200 miles

Bus Driver/Number chaperone transport w/ parent permission Bus Driver/ Number _____

Will Chaperones have a list (roll) that they are responsible for? yes

As you plan the trip, will all children be given instructions as to what they should do if they become separated (lost) from the group? yes

Will you have on file parental release forms signed by parents or legal guardians? yes

Explain the educational value of the trip: This trip is a way to provide a structure environment for learning technique, coordination, and physical fitness. They will develop teamwork and social skills.

Total Cost Estimate \$500.00

Plans for meeting the costs fundraising / parents meet remaining balance - hoping this cost will be less than \$200.00 after fundraising

Transportation cost for educational trips shall be calculated in the following manner:
\$16.00 per hour for driver (2 hour minimum)
\$ 3.15 per hour to cover fixed charges (SS, retirement. etc.)
\$19.15 total to be remitted to the central office per hour

Reimbursement for the bus and fuel shall be made at the rate of **\$.75** per mile.
*Refer to Board Policy 4.302

[Signature]
Principal's Signature
APPROVED
BY WC SUPERINTENDENT
Superintendent's Signature

5/6/26
Date
5/7/26
Date

Date Approved by the Board of Education _____