

Public Comment Period

There shall be a public comment period for each meeting with actionable items on the agenda, with the exception of teacher disciplinary hearings. Comments shall be limited to topics listed on the agenda and matters that are germane to the school board's jurisdiction.

The total public comment period shall be for no more than three (3) minutes. If an individual wishes to address the Board, he/she shall sign up on the form provided before the beginning of the board meeting to request time to speak. Each speaker shall be given no more than (3) minutes. Delegations must select only one individual to speak on their behalf unless otherwise determined by the Board. *Board Policy 1.609 Appeals to and Appearances Before the Board*

WASHINGTON COUNTY BOARD OF EDUCATION

April 2, 2026

6:00 PM

Central Office

- I. Call to Order**
- II. West View Elementary Students**
- III. Daniel Boone High Girls Basketball Team**
- IV. Presentation from BrightRidge**
- V. Recognition of Tenured Personnel**
- VI. Consideration of Meeting Agenda**
- VII. Public Comment**
- VIII. Approval of Meeting Minutes**
 - A. March 10, 2026**
March 24, 2026
- IX. Announcements**
 - A. April 2, 2026; 2:00 p.m.**
County Commission HEW Committee
 - B. April 3, 2026**
Good Friday
District Offices Closed/No School
April 4, 2026
Easter
April 5, 2026
Easter Monday
District Offices Closed/No School
 - C. April 8, 2026; 9:00 a.m.**
County Budget Committee

- D. **April 14, 2026; 5:30 p.m.**
Joint Meeting of the Board of Education and County Commission
- E. **April 27, 2026; 6:00 p.m.**
County Commission Meeting
- F. **April 28, 2026; 6:00 p.m.**
Monthly Board Workshop
- G. **April 30, 2026; 7:00 p.m.**
Daniel Boone High and David Crockett High Top Ten % Banquet
Brinkley Center
- H. **May 4, 2026; 7:00 p.m.**
CTE Banquet; Daniel Boone High and David Crockett High
Brinkley Center
- I. **May 8, 2026; 6:00 p.m.**
Asbury Graduation
Daniel Boone High Gymnasium
- J. **May 11, 2026; 6:00 p.m.**
Teacher of the Year Banquet
Grace Meadows Farm
- K. **May 16, 2026; Graduations; ETSU Mini-Dome**
David Crockett High; 9:00 a.m.
Daniel Boone High; 1:00 p.m.
- L. **May 21, 2026**
Last Student Day
- X. **Superintendent's Report**
 - A. **Student Board Member Hannah Campbell, David Crockett High School**
 - B. **Enrollment Report**
 - C. **Maintenance Report**
 - D. **Monthly Financials**
 - E. **Grant Report**
 - F. **Personnel Report**
 - G. **Day Trips**
 - H. **Other**
- XI. **Consideration of Consent Agenda**
 - A. **Request for New Clubs**
 - 1. **Ridgeview Elementary Dance Club**
 - 2. **Boones Creek Elementary Dance Club**
 - B. **Purchase Orders**
 - 1. **Dietary Requisition No 1430260255; Pepsi Cola Company; Add On Order for 2026; \$15,000.00; Line Item 143E 73100 422**
 - 2. **Purchase Order 7648; College Board; Pre AP Courses; Daniel Boone High and David Crockett High; Not to exceed \$20,000.00; Line Item 141E 71100-449**
 - 3. **Purchase Order 7548; B&H, New York, NY; Wacom Display Tablets (15); David Crockett High; CTE Digital Arts; Funded by ISM Grant; \$14,885.00 (\$959 ea); Line Item 141E 71300-730-000-00000-002**

4. **Purchase Order 7018; College Board; AP Exams for Daniel Boone High and David Crockett High; Price Modification from prior Board approval 12/4/25 for \$44,000); Not to exceed \$50,000.00; Line item 141E 72130-322**
 5. **Purchase Order 7463; The Stage Depot, Ladera Ranch, CA; Stage System; Lamar Elementary; Funded by ISM Grant; \$24,999.00; Line Item 141E 71300 730 000 00000 002**
 6. **Purchase Order 7577; Leonard Truck Outfitters, Johnson City, TN; Shelving Kits and Ladder Rack for 2 Vans (Installation Included); Maintenance Department; \$24,178.00; Line Item 141E 72710 729**
 7. **Purchase Order 35917; Solution Tree, Bloomington, IN; Professional Development (3 Days); Jonesborough Elementary; \$21,300.00; Line Item 142E 722100 524 100**
- C. Request to Release Bids**
1. **Request to release bids for intercoms at West View Elementary and David Crockett High**
 2. **RFP for Beverage Provider**
 3. **Release Bids for Kitchen Floor Replacement at West View Elementary and Sulphur Springs Elementary**
- D. Request to Purchase 625 Chromebooks (\$288,543.75); 330 Access Points (\$211,092.75); Funded by County Educational Capital Fund**

XII. Discussions/Presentations

- A. Envelope Machine Request**
- B. Trash Compactors for Daniel Boone High, David Crockett High, and Grandview Elementary**
- C. Purchase Orders**
 1. **Purchase Order 29003; BSN Sports; Daniel Boone High; Middle School Football Uniforms; Not to Exceed \$11,000.00; Line Item 145L 620**
 2. **Purchase Order 7718; Amitrace, Norcross, GA; VidPod Turnkey Video Podcast; Sole Source; Lamar Elementary; Funded by ISM Grant; \$15,990.00; Line Item 141E 71100 722 000 00000 002**
 3. **Purchase Order 7783; Gallopade Textbooks; TN 26-27 GAP Renewal Grades 3-4; \$56,336.09; Line Item 141E 71100-449**
 4. **Purchase Order 7782; SAVAAS Learning Company, Paramus, NJ; Additional High School Biology Foundations Workbooks; \$33,288; Line Item 141E 71100 449**
 5. **Purchase Order 7652; Presentation Solutions, Buckner, KY; BuyBoard Contract #76025; Color Pro Banner Maker Supplies; Lamar Elementary; \$19,058.61; Funded by ISM Grant; Line Item 141E 71300 429 000 00000 002**
 6. **Purchase Order 7788; Benchmark Education; Renewal (3 yrs) SY 26-27,27-28,28-29; \$427,360.20; Line Item 141E 71100 449**
 7. **Purchase Order 7785; Magma Math; Renewal (Year 2) SY27-28; \$76,720.00; Line Item 141E 71100 449**

- 8. **Purchase Order 7784; Code HS Online Classroom; Computer Science; High Schools; 7/1/26-6/30/27; \$22,225.00; Line Item 141E 71100 449**
- D. **Review of bids for kitchen equipment at Gray Elementary and South Central Elementary; Line Item 143E 73100-710**
- E. **Discuss the process to develop a formal plan of action for potential PreK-5 and 6-8 schools reconfigurations.**
- F. **Consideration of Board Resolution Opposing School Vouchers**
- G. **Policy 1.609 Appeals to and Appearances Before the Board - 1st and 2nd Reading**
- H. **Overnight Trip Requests**
 - 1. **David Crockett High School**
July 5th-10th, 2026
Washington, DC
FCCLA 9th-12th Grades
Duration: 5 Days
 - 2. **David Crockett High School**
April 20th-23rd, 2026
Franklin, TN
Residential and Commercial Construction Gr.10-12th
Duration: 3 Days

XIII. Adjournment

WASHINGTON COUNTY BOARD OF EDUCATION

March 10, 2026; 6:00 PM; Central Office

Those present were Chairman Annette Buchanan, Vice-Chairman David Hammond, Eric Barnes, Whitney Riddle, Mike Masters, Keith Ervin, Vince Walters, Chad Fleenor, Gregg Huddleston, and Superintendent Jerry Boyd.

I. Call to Order

Mr. Walters led a prayer, followed by Lily Fleenor who led the pledge to the flag.

II. Grandview Elementary BETA Club

III. South Central Elementary CTE Class: Food Truck Design Project

IV. 2026 SCOPE Attendees and Student Board Members

2026 SCOPE Attendees AJ Wynn, Journey Higgins, Ellaleigh Baker, and Jo Robinson (absent) shared about attending the Conference.

David Crockett High Students AJ Wynn and Journey Higgins; and Daniel Boone High Students Conner Davis and Sophia Ashby were introduced as the SY26-27 Student Board Members.

V. Presentation from BrightRidge (rescheduled)

VI. Consideration of Meeting Agenda

Chad Fleenor moved for approval of the meeting agenda; with the addition of consideration by the Board to send a letter of opposition to State Legislators of prohibiting Board of Educations from entering into MOU's with professional educators. Whitney Riddle seconded the motion which carried on roll call vote:

- Eric Barnes: *yes*
- Keith Ervin: *yes*
- Chad Fleenor: *yes*
- David Hammond: *yes*
- Gregg Huddleston: *yes*
- Mike Masters: *yes*
- Whitney Riddle: *yes*
- Vince Walters: *yes*
- Annette Buchanan: *yes*

VII. Public Comment

No public comment.

VIII. Approval of Meeting Minutes

February 5, 2026

February 10, 2026

February 24, 2026

Chad Fleenor moved for approval of the meeting minutes, as presented. Whitney Riddle seconded the motion which carried on roll call vote:

- Eric Barnes: *yes*
- Keith Ervin: *yes*
- Chad Fleenor: *yes*
- David Hammond: *yes*
- Gregg Huddlestone: *yes*
- Mike Masters: *yes*
- Whitney Riddle: *yes*
- Vince Walters: *yes*
- Annette Buchanan: *yes*

IX. Announcements

A. March 5, 2026; 1:00 p.m.

County Commission HEW Committee

B. March 11, 2026; 9:00 a.m.

County Commission Budget Meeting

C. March 16-20, 2026

Spring Break

District Offices Closed Friday, March 20

D. March 24, 2026; 12:00 a.m. - 1:00 p.m.

Community meeting to receive input in regard to updating the Board's Five-Year Strategic Plan

Central Office Board Room

E. March 24, 2026; 6:00 p.m.

Board Workshop

F. April 30, 2026; 7:00 p.m.

Daniel Boone High and David Crockett High Top Ten Percent Banquet

Millenium Center Ballroom

G. May 4, 2026; 7:00 p.m.

Daniel Boone High and David Crockett High CTE Banquet

Millenium Center

H. May 8, 2026; 6:00 p.m.

Asbury Graduation; Daniel Boone High School Gym

I. May 11, 2026; 6:00 p.m.

Teacher of the Year Banquet

Grace Meadows Farm

**J. May 16, 2026; Graduation Ceremonies; ETSU Mini Dome
David Crockett High School 9:00 a.m.
Daniel Boone High School 1:00 p.m.**

X. Superintendent's Report

- A. Lilly Fleenor, Daniel Boone High School**
- B. Enrollment Report**
- C. Personnel Report**
- D. Grant Report**
- E. Maintenance Report**
- F. Monthly Financials**
- G. Day Field Trips**
- H. Other**

XI. Consideration of Consent Agenda

A. Purchase Orders

- 1. Purchase Order 7367 Sphero, Greenville, TX; Bolt+Power Pack & Space/Soccer Code Mat; Blueprint Engineering Class Pack; Sole Source; Gray Elementary; Funded by ISM Grant; \$11, 648.00; Line Item 141E 71300 730 002**
- 2. Purchase Order 7382; Presentation Solutions, Buckner, KY; Diamond XL 2 Color Pro Ultra (Indoor/Outdoor Poster & Banner Maker); Ridgeview Elementary; BuyBoard #760-25; Funded by ISM Grant; \$12, 394.05; Line Item 141E 71300 730 000 00000 002**
- 3. Purchase Order 7385; Presentation Solutions, Buckner, KY; Diamond XL 2 Color Pro Ultra (Indoor/Outdoor Poster & Banner Maker), Stadium/Gym Posters starter kit, Different color tapes, Standard 24" and 36" Bond paper; Gray Elementary; BuyBoard #760-25; Funded by ISM Grant; \$14,363.00; Line Item 141E 71300 730 000 00000 002**

B. Overnight Trip Requests

- 1. DCHS
March 14th-March 19th, 2026
Gulf Shores, AL
Softball Team
Duration: 6 Days**
- 2. DCHS
April 6th-11th, 2026
Chattanooga, TN
FCCLA State Leadership Conference
Duration: 6 Days**

3. DCHS
March 29th-April 1st, 2026
Chattanooga, TN
HOSA State Leadership Conference
Duration: 3 days

Chad Fleenor moved for approval of the consent agenda. Vince Walters seconded the motion which carried on roll call vote:

- Eric Barnes: *yes*
- Keith Ervin: *yes*
- Chad Fleenor: *yes*
- David Hammond: *yes*
- Gregg Huddlestone: *yes*
- Mike Masters: *yes*
- Whitney Riddle: *yes*
- Vince Walters: *yes*
- Annette Buchanan: *yes*

XII. Discussions/Presentations

Chad Fleenor moved for approval of the Overnight Trip Requests, as presented. Whitney Riddle seconded the motion which carried on roll call vote:

- Eric Barnes: *yes*
- Keith Ervin: *yes*
- Chad Fleenor: *yes*
- David Hammond: *yes*
- Gregg Huddlestone: *yes*
- Mike Masters: *yes*
- Whitney Riddle: *yes*
- Vince Walters: *yes*
- Annette Buchanan: *yes*

A. Additional Overnight Trip Requests

1. David Crockett High School
September 4th-6th, 2026
Gatlinburg, TN
Girls Soccer Team
Duration: 3 Days

2. David Crockett High School
April 17th-19th, 2026
Matthews, NC
Track and Field
Duration: 2 days

3. Daniel Boone High School
March 10th-14th, 2026
Murfreesboro, TN
State Basketball Tournament/Girls Basketball Team-Coaches
Duration: 4 days

4. David Crockett High School
July 16-19th, 2026
University of Tennessee Chattanooga, TN
Girls Soccer Team
Duration: 4 days

5. David Crockett High School
March 18th-22nd, 2026
Millington, TN
Baseball Team
Duration: 5 days

6. Daniel Boone High School
March 11th-14th, 2026
Murfreesboro, TN
State Basketball Tournament-Cheerleaders
Duration: 3 days

B. Approval of a Middle School CTE Enterprise Club

Eric Barnes moved for approval of a Middle School CTE Enterprise Club. Vince Walters seconded the motion which carried on roll call vote:

- Eric Barnes: *yes*
- Keith Ervin: *yes*
- Chad Fleenor: *yes*
- David Hammond: *yes*
- Gregg Huddlestone: *yes*
- Mike Masters: *yes*
- Whitney Riddle: *yes*
- Vince Walters: *yes*
- Annette Buchanan: *yes*

C. Approval of Frontier Trail Proposal

Chad Fleenor moved for approval of the Frontier Trail Proposal. Gregg Huddlestone seconded the motion which carried on roll call vote:

- Eric Barnes: *yes*
- Keith Ervin: *yes*
- Chad Fleenor: *yes*
- David Hammond: *yes*

- Gregg Huddlestone: *yes*
- Mike Masters: *yes*
- Whitney Riddle: *yes*
- Vince Walters: *no*
- Annette Buchanan: *yes*

D. Awarding of bid for greenspace at Boones Creek Elementary; Funded by ISM Grant

Chad Fleenor moved to award bid to Custom Building Group, Inc., Kingsport, TN. Gregg Huddlestone seconded the motion which carried on roll call vote:

- Eric Barnes: *yes*
- Keith Ervin: *yes*
- Chad Fleenor: *yes*
- David Hammond: *yes*
- Gregg Huddlestone: *yes*
- Mike Masters: *yes*
- Whitney Riddle: *yes*
- Vince Walters: *yes*
- Annette Buchanan: *yes*

E. Anticipated Tenure Recommendations

Gregg Huddlestone moved to award tenure status to the personnel recommended, as presented. Chad Fleenor seconded the motion which carried on roll call vote:

- Eric Barnes: *yes*
- Keith Ervin: *yes*
- Chad Fleenor: *yes*
- David Hammond: *yes*
- Gregg Huddlestone: *yes*
- Mike Masters: *yes*
- Whitney Riddle: *yes*
- Vince Walters: *yes*
- Annette Buchanan: *yes*

F. Approval of Purchase Orders

Chad Fleenor moved for approval of the purchase orders, as presented. Vince Walters seconded the motion which carried on roll call vote:

- Eric Barnes: *yes*
- Keith Ervin: *yes*
- Chad Fleenor: *yes*
- David Hammond: *yes*
- Gregg Huddlestone: *yes*
- Mike Masters: *yes*
- Whitney Riddle: *yes*

- Vince Walters: *yes*
- Annette Buchanan: *yes*

1. Purchase Order 35920; TNTP, Inc., New York, NY; ELA Curriculum Support; System-wide; HQIM; Literacy Implementation Grant; Year 5; \$36,400.00; Line Item 142E 72210 399 951

2. Purchase Order 7460; Inspire Business Interiors, Johnson City, TN; Omnia #R240117; CTE Classroom Furniture (1 Agriscience, 3 Health Science Classrooms) Daniel Boone High School; Funded by ISM Grant; \$70,587.84; Line Item 141E 71100 722 000 00000 002

3. Purchase Order 7459; Presentation Solutions, Inc., Buckner, KY; Diamond XL2 Indoor/Outdoor Poster & Banner Maker; Lamar Elementary; Funded by ISM Grant; \$12,394.05; Line Item 141E 71300 730 000 00000 002

4. Purchase Order 7544; Presentation Solutions, Inc., Buckner, KY; Supplies for Indoor/Outdoor Banner Maker; Boones Creek Elementary; Buy Board Contract #760-25; Funded by ISM Grant; \$19,058.00; Line Item 141E 71300 429 000 00000 002

Gregg Huddleston made a motion for the Washington County Board of Education to send a letter of opposition to HB2226 and SB2445. David Hammond seconded the motion which carried on roll call vote:

- Eric Barnes: *yes*
- Keith Ervin: *yes*
- Chad Fleenor: *yes*
- David Hammond: *yes*
- Gregg Huddleston: *yes*
- Mike Masters: *yes*
- Whitney Riddle: *yes*
- Vince Walters: *yes*
- Annette Buchanan: *yes*

XIII. Adjournment

School	-2	-1	0	1	2	3	4	5	6	7	8	9	10	11	12	Total
Boones Creek Elementary School	17	14	86	83	110	84	95	79	102	77	78					825
Daniel Boone High School												280	271	271	223	1045
David Crockett High School												275	277	265	192	1009
Fall Branch Elementary School			20	16	31	19	22	36	26	24	21					215
Gray Elementary School	19		48	53	54	50	61	51	59	60	54					509
Grandview Elementary School	17	13	45	67	57	67	56	70	51	54	61					558
Jonesborough Elementary School	35	1	74	93	110	99	114	111	84	91	88					900
Lamar Elementary School	19		45	45	45	48	46	32	38	40	42					400
Ridgeview Elementary School	15		44	59	62	88	76	75	64	86	96					665
South Central Elementary School			15	10	20	15	22	26	17	11	16					152
Sulphur Springs Elementary School	16		33	37	35	34	44	34	51	38	44					366
University School			18	21	22	18	23	48	52	49	52	83	83	82	81	632
West View Elementary School			18	25	26	24	29	33	43	29	36					263
Tennessee Virtual Learning Academy												3	9	13	6	31
Washington County Special Ed Service School	5	15	3	3	1		2								1	30
Total	143	43	449	512	573	546	590	595	587	559	588	641	640	631	503	7600

Full District - <https://app.espace.cool/Woms/PublicAnalytic/Index?guid=dde5295c-df1a-474a-b823-4a8bd9b65d97>

Asbury - <https://app.espace.cool/Woms/PublicAnalytic/Index?guid=e61a4c0a-ed39-485a-befd-bc76b00a5b2b>

BCE - <https://app.espace.cool/Woms/PublicAnalytic/Index?guid=e9a185b1-26b1-409c-a97a-bf1bf13816ad>

DBHS - <https://app.espace.cool/Woms/PublicAnalytic/Index?guid=91dfdef2-bff7-43b4-a04e-16dc73a3500a>

DCHS - <https://app.espace.cool/Woms/PublicAnalytic/Index?guid=7cc09814-5753-44ee-bbea-8c233512630a>

CO - <https://app.espace.cool/Woms/PublicAnalytic/Index?guid=14237d1d-34fc-481f-a224-404f9f6d6a5c>

FBES - <https://app.espace.cool/Woms/PublicAnalytic/Index?guid=7bc55f59-47d1-4b33-a1fb-96a42b3e4968>

GVES - <https://app.espace.cool/Woms/PublicAnalytic/Index?guid=0b061f31-9847-4a14-afd8-35b2f25897bb>

GES - <https://app.espace.cool/Woms/PublicAnalytic/Index?guid=3567a5e2-e75a-41d2-af94-2871ce93f10a>

JES - <https://app.espace.cool/Woms/PublicAnalytic/Index?guid=e9233523-ef22-4440-a3ca-753bb4dad5d>

LES - <https://app.espace.cool/Woms/PublicAnalytic/Index?guid=3e2eb3b6-42f5-4932-aafc-596fc3581fa0>

Midway - <https://app.espace.cool/Woms/PublicAnalytic/Index?guid=557087e0-5f3e-4951-a538-efa094a7de7b>

RVES - <https://app.espace.cool/Woms/PublicAnalytic/Index?guid=e445ed82-298f-47fc-9f1c-12d68795ffd1>

SCES - <https://app.espace.cool/Woms/PublicAnalytic/Index?guid=19182fea-4f76-4570-8038-5ee9ec8aa93e>

SSES - <https://app.espace.cool/Woms/PublicAnalytic/Index?guid=be7abc19-2a4f-4d34-a9d9-5f3b7ac0dcd4>

WVES - <https://app.espace.cool/Woms/PublicAnalytic/Index?guid=c66a8c57-f4d8-47c3-a1f6-05c18bb47ccf>

Bus Garage - <https://app.espace.cool/Woms/PublicAnalytic/Index?guid=3f6c86d7-c52e-45fe-aff-4ffda625fd7>

Revenue and Expense Summaries for February 2026 for the 141, 142, & 143 Funds

141-Fund Revenues

- Revenue for February 2026 was \$11,513,370 compared to \$11,015,702 February 2025. This is a increase of \$500,670
 - The main key variations from last February are listed below.
 - 40110 Current Property Tax was an increase of \$113,322 which mostly due to timing of Trustee collections.
 - 40210 Local Options Sales Tax was an increase of \$69,162.00.
 - 46510 TISA was an increase of \$186,990.00.
 - 46790 Other Vocational was an increase of \$56,905 due to timing and or usage of the CTE ISM Grant.
 - You can evaluate the Rural Option Sales Tax impact from the prior formula change to both the Washington County Schools and Johnson City Schools on document (4-A_Washington County Rural Option Sales Tax_February 2026).

141-Fund Expenses

- Expenses for February 2026 are coming in at \$8,483,285.28. This is (\$395,140.81) more than February 2025.
 - Major variances from February 2025
 - Overall salary expenses were \$336,646.07 more than February 2025.
 - Vocational Instructional Equipment 141E 71300-730-000-00000-002 was \$71,933.88 more than last February due to timing of purchases through the CTE-ISM Grant.
- You can also reference a report that gives some additional details this month on BOE Connected titled as (1-D_Summary_141_Payables Detail February 2026).

142-Federal Fund

- Due to timing of state funds received, the Federal Projects fund saw \$0 of flow through revenues in February 2026. It is anticipated the March 2026 revenue report will have both February and March revenues combined. The breakdown of the reimbursements are listed below.
- The current breakdown of revenue/reimbursements received are listed below:
 - Consolidated/Title Grants accounted for 0%
 - SPED grants accounted for 0%
 - All other grants accounted for 0%
- You can also reference a report that gives some additional details this month on BOE Connect titled as (2-A_Summary_142_Payables Detail February 2026).

143-Dietary Fund (From the Trustee's Report-Unreconciled)

- Revenue for February 2026 came in around \$367,290.73 which is \$16K less than February 2025.
- Expenses came in around \$371K which is around \$81K less than February of 2025.
- The unreconciled Dietary Fund balance for February 2026 off the Trustee's Revenue Report is just over \$1.552 Million.
 - Dietary experienced an increase of around \$116K in fund balance for February 2026 from the prior month.
 - In comparison to February 2025, the Dietary Fund balance has decreased by around \$188K, this is off the Trustee report which is an unreconciled report.
 - We will need to keep watch on this closely as we get close to the \$750K minimum fund balance threshold.

Account Level		2025-26	2024-25	2025-26	February	2024-25	2025-26	FYTD	2025-26	2025-26			
Fnd	Acct	Obj	Prj	Description	Revised Budget	February	February	Variance	FYTD Activit	FYTD Activit	Variance	Uncollected Reve	FY % Coll
141	40110	000	000	CURRENT PROPERTY TAX	13,552,792	3,744,591	3,857,913	113,322	12,581,113	12,439,084	-142,029	1,113,708	91.78
141	40120	000	000	TRUSTEE'S COLLECTIONS - PRIOR	98,228	28,098	55,916	27,819	57,514	256,593	199,079	-158,365	261.22
141	40125	000	000	CLK/MASTER COLLECTIONS-PRIOR	644	0	0	0	0	94	94	550	14.61
141	40130	000	000	CIRCUIT CLERK/CLERK & MASTER C	61,916	3,197	2,869	-328	37,046	51,175	14,129	10,741	82.65
141	40140	000	000	INTEREST AND PENALTY	61,707	6,545	11,029	4,484	31,889	50,071	18,182	11,636	81.14
141	40162	000	000	PAYMENTS IN LIEU OF TAXES - LO	216,227	0	0	0	605	0	-605	216,227	0.00
141	40163	000	000	PAYMENTS IN LIEU OF TAXES - OT	25,410	2,081	1,994	-87	14,354	3,367	-10,987	22,043	13.25
141	40210	000	000	LOCAL OPTION SALES TAX	21,000,000	2,184,610	2,253,772	69,162	15,118,441	15,690,315	571,873	5,309,685	74.72
141	40270	000	000	BUSINESS TAX	578,402	32,300	24,681	-7,619	116,720	117,214	495	461,188	20.27
141	40275	000	000	MIXED DRINK TAX	3,542	1	0	-1	7,935	19	-7,916	3,523	0.54
141	40320	000	000	BANK EXCISE TAX	109,398	0	0	0	0	0	0	109,398	0.00
141	41110	000	000	MARRIAGE LICENSE	1,727	80	59	-21	1,170	997	-174	730	57.71
141	43517	000	000	TUITION - OTHER	129,980	14,450	7,150	-7,300	91,640	87,650	-3,990	42,330	67.43
141	43581	000	000	COMMUNITY SERVICE FEES - CHILD	665,548	69,963	45,974	-23,988	448,042	392,727	-55,315	272,821	59.01
141	44120	000	000	RENT ON BUILDINGS	2,830	750	0	-750	1,750	1,064	-686	1,766	37.60
141	44130	000	000	SALE OF MATERIALS AND SUPPLIES	1,914	0	0	0	1,480	1,449	-31	465	75.68
141	44520	000	000	INSURANCE RECOVERY	74,207	0	0	0	0	0	0	74,207	0.00
141	44530	000	000	SALE OF EQUIPMENT	55,228	310	0	-310	42,615	0	-42,615	55,228	0.00
141	44570	000	000	CONTRIBUTIONS & GIFTS	201,936	0	4,353	4,353	201,936	42,835	-159,101	159,101	21.21
141	44990	000	000	OTHER LOCAL REVENUES - TAGS	393	36	72	36	268	18,989	18,721	-18,596	4,831.82
141	44991	000	000	OTHER LOCAL REVENUE	87,799	652	926	275	58,187	36,779	-21,407	51,020	41.89
141	44992	000	000	OTHER LOCAL REV- ROYALTIES/CO	33,608	2,992	2,503	-490	23,287	18,948	-4,340	14,661	56.38
141	45550	000	000	CLERK & MASTER	0	0	0	0	0	-10,812	-10,812	10,812	0.00
141	46510	000	000	TISA	50,837,399	4,899,384	5,086,374	186,990	35,044,224	36,378,620	1,334,396	14,458,779	71.56
141	46515	000	000	EARLY CHILDHOOD EDUCATION	161,697	0	0	0	159,969	30,183	-129,786	131,514	18.67
141	46550	000	000	DRIVER EDUCATION	32,737	0	0	0	0	0	0	32,737	0.00
141	46590	000	000	OTHER STATE EDUCATION FUNDS	761,614	0	5,143	5,143	0	1,422,878	1,422,878	-661,264	186.82
141	46596	000	000	PAID PARENTAL LEAVE	0	0	0	0	0	820	820	-820	0.00
141	46610	000	000	CAREER LADDER PROGRAM	52,713	0	0	0	29,354	22,676	-6,678	30,037	43.02
141	46790	000	000	OTHER VOCATIONAL	1,000,000	0	56,905	56,905	996,898	475,003	-521,894	524,997	47.50
141	46851	000	000	STATE REVENUE SHARING - T.V.A.	1,353,820	0	0	0	668,572	747,577	79,005	606,243	55.22
141	46980	000	000	OTHER STATE GRANTS	768,730	0	28,438	28,438	159,586	101,957	-57,629	666,773	13.26
141	47141	000	000	TITLE I GRANTS TO LOCAL EDUCAT	1,624	0	0	0	1,624	0	-1,624	1,624	0.00
141	47146	000	000	ENGLISH LANGUAGE AQU. GRANTS	8,093	0	0	0	0	0	0	8,093	0.00
141	47640	000	000	ROTC REIMBURSEMENT	181,443	25,662	49,408	23,746	114,724	114,065	-658	67,378	62.87
141	48990	000	000	OTHER	615,515	0	0	0	346,339	37,450	-308,889	578,065	6.08
141	49700	000	000	INSURANCE RECOVERY	17,821	0	20,891	20,891	17,821	45,170	27,348	-27,349	253.46
141	49800	000	000	OPERATING TRANSFERS	100,000	0	0	0	889,464	0	-889,464	100,000	0.00
Grand Revenue Totals					92,856,642	11,015,702	11,516,370	500,670	67,264,567	68,574,957	1,310,390	24,281,686	73.85

Account Level		2025-26	2024-25	2025-26	February	2024-25	2025-26	FYTD	2025-26	2025-26
<u>Fnd Acct</u>	<u>Obj Prj Description</u>	<u>Revised Budget</u>	<u>February</u>	<u>February</u>	<u>Variance</u>	<u>FYTD Activit</u>	<u>FYTD Activit</u>	<u>Variance</u>	<u>Uncollected Reve</u>	<u>FY % Coll</u>
Number of Accounts: 38										

***** End of report *****

	A	B	C	D	E	F	G	H	I	J	K	L	M	N
1	SALES TAX TRACKING													
2	141R 40210													
3														
4	YEAR	TOTAL	July	August	September	October	November	December	January	February	March	April	May	June
5														
6	1995-96	7,964,549.95	611,536.43	650,039.30	596,451.81	626,656.64	665,950.77	645,367.17	793,944.02	872,382.08	581,914.60	553,125.28	700,497.25	666,684.60
7	1996-97	8,336,657.30	668,621.91	695,781.06	645,426.90	665,996.66	712,853.08	700,269.94	714,674.24	917,676.40	636,923.88	635,082.70	639,073.10	704,277.43
8	1997-98	9,028,886.69	721,817.32	780,093.18	704,916.44	717,825.19	798,852.97	747,016.98	760,728.85	1,024,051.84	649,227.26	638,150.71	787,948.69	698,257.26
9	1998-99	9,418,336.41	729,516.21	780,343.86	758,281.99	769,388.96	789,685.47	793,285.27	808,672.84	1,049,009.40	669,997.81	685,164.29	785,149.89	799,840.42
10	1999-00	9,925,491.78	761,578.86	848,424.57	757,359.52	832,656.56	798,763.84	812,346.45	826,725.33	1,142,546.37	711,564.82	750,908.81	878,078.63	804,538.02
11	2000-01	10,302,344.61	804,204.89	905,337.72	804,216.35	854,382.25	909,453.32	794,725.07	882,257.31	1,178,919.01	758,048.36	742,368.32	860,763.60	807,668.41
12	2001-02	10,532,891.37	808,555.26	866,353.62	796,577.42	828,852.58	889,601.40	870,074.31	872,050.60	1,199,611.30	768,580.66	790,051.97	938,373.85	904,208.40
13	2002-03	10,638,027.23	906,277.17	974,296.94	882,472.09	811,952.60	891,857.89	850,620.49	926,239.19	1,186,561.52	763,464.89	727,893.01	896,976.99	819,414.45
14	2003-04	11,067,961.48	852,744.87	931,182.77	884,455.76	904,582.89	939,687.81	883,319.35	949,214.33	1,224,464.85	796,000.63	798,184.90	971,370.65	932,752.67
15	2004-05	12,141,242.02	959,427.54	1,003,502.83	961,878.30	960,187.49	981,448.59	962,577.75	1,007,923.70	1,354,489.51	869,026.19	1,061,329.31	1,043,956.65	975,494.16
16	2005-06	12,336,585.09	955,565.19	1,032,019.38	1,019,556.16	1,105,255.87	1,019,172.70	995,288.52	1,052,343.46	1,443,274.33	811,741.53	876,236.72	1,048,459.42	977,671.81
17	2006-07	12,847,409.98	1,026,100.62	1,085,657.40	1,035,122.60	1,044,487.23	1,102,319.02	1,016,987.55	980,057.85	1,443,529.82	1,018,080.51	955,096.95	1,130,190.78	1,009,779.65
18	2007-08	13,475,705.49	1,079,389.94	1,164,602.82	1,112,875.15	1,123,975.96	1,128,221.21	1,082,375.90	1,170,203.04	1,480,368.07	934,432.24	1,003,760.54	1,131,648.39	1,063,852.23
19	2008-09	13,118,209.41	1,121,283.53	1,163,968.03	1,069,948.56	1,109,937.70	1,119,035.49	1,083,890.72	1,091,466.64	1,441,865.04	858,933.82	992,382.26	1,070,456.28	995,041.34
20	2009-10	12,609,635.54	1,008,819.19	1,099,406.55	992,789.10	1,066,457.07	1,052,452.00	997,413.03	1,039,892.90	1,366,560.85	888,185.43	945,035.53	1,121,973.47	1,030,650.42
21	2010-11	13,050,988.91	1,054,228.59	1,128,189.89	1,037,584.63	1,056,839.88	1,086,389.24	1,054,070.16	1,094,354.84	1,429,909.64	867,910.25	1,009,209.95	1,143,124.29	1,089,177.55
22	2011-12	13,808,173.10	1,081,535.67	1,228,666.98	1,138,627.12	1,132,824.15	1,125,406.77	1,090,432.58	1,133,742.86	1,526,365.45	1,016,848.19	1,065,106.10	1,194,803.93	1,073,813.30
23	2012-13	13,530,626.40	1,137,511.17	1,176,802.38	1,071,451.21	1,148,396.78	1,150,162.91	1,096,243.83	1,142,826.70	1,516,667.47	785,969.43	1,037,806.81	1,169,086.53	1,097,701.18
24	2013-14	13,756,487.05	1,138,760.08	1,166,521.54	1,081,327.46	1,126,284.98	1,099,605.17	1,103,883.00	1,136,848.35	1,508,355.06	971,672.20	1,055,143.00	1,275,350.78	1,092,735.43
25	2014-15	14,057,315.44	1,142,752.51	1,227,623.79	1,131,340.43	1,189,344.14	1,190,743.05	1,134,318.63	1,199,396.63	1,588,182.32	889,370.36	1,008,340.90	1,211,709.73	1,144,192.95
26	2015-16	14,722,621.29	1,241,008.04	1,233,271.57	1,166,463.36	1,203,804.59	1,229,321.78	1,188,390.71	1,246,671.22	1,641,380.40	1,070,197.64	997,571.40	1,284,815.87	1,219,724.71
27	2016-17	14,747,100.82	1,183,242.43	1,271,727.15	1,176,910.43	1,236,255.66	1,252,584.64	1,203,060.65	1,234,360.41	1,672,699.50	977,436.65	1,033,968.30	1,288,153.30	1,216,701.70
28	2017-18	15,349,677.89	1,205,951.87	1,271,772.24	1,218,781.58	1,210,362.79	1,249,834.14	1,202,844.48	1,292,583.56	1,624,509.44	1,147,863.70	1,134,847.93	1,558,692.28	1,231,633.88
29	2018-19	15,494,923.37	1,278,018.86	1,291,098.17	1,228,129.70	1,291,319.95	1,284,627.33	1,285,032.84	1,328,654.02	1,591,314.78	1,249,696.22	1,156,902.45	1,353,122.68	1,157,006.37
30	2019-20	16,025,666.39	1,344,150.84	1,344,028.39	1,307,238.15	1,361,539.99	1,316,157.76	1,348,576.15	1,379,403.02	1,729,590.49	1,212,600.58	1,176,918.48	1,324,871.88	1,180,590.66
31	2020-21	18,656,288.63	1,395,726.34	1,499,518.71	1,411,794.82	1,382,621.85	1,465,357.10	1,472,356.92	1,510,857.41	1,869,107.00	1,464,509.00	1,610,321.46	1,840,466.32	1,733,651.70
32	2021-22	20,931,816.79	1,727,238.03	1,711,551.64	1,741,191.00	1,659,586.42	1,736,797.58	1,711,047.73	1,862,765.56	2,152,612.02	1,607,027.31	1,654,556.12	1,930,358.42	1,437,084.96
33	2022-23	22,857,494.37	1,898,693.27	1,921,027.35	1,828,958.80	1,803,789.27	1,926,053.40	\$ 1,878,522.95	1,931,396.64	2,269,090.00	1,801,473.36	1,668,098.37	1,966,856.01	1,963,534.95
34	2023-24	21,601,025.58	1,990,790.71	1,789,745.09	1,753,458.04	1,682,817.47	1,736,275.41	\$ 1,766,029.31	1,813,960.70	2,266,646.75	1,586,385.69	1,654,346.13	1,818,284.57	1,742,285.71
35	2024-25	22,244,594.11	1,824,507.00	1,833,757.00	1,830,075.87	1,824,105.97	1,769,380.11	\$ 1,954,793.00	1,897,212.04	2,184,610.00	1,638,744.00	1,634,652.00	1,942,460.00	1,910,297.12
36	2025-26	15,690,314.93	1,883,990.00	1,890,348.82	1,942,413.41	1,934,260.34	1,909,227.43	\$ 1,929,801.54	1,946,501.06	2,253,772.33				
37														
38		Prior Year-to-Date Comparison												
39	INC / (DEC)	571,873.94	59,483.00	56,591.82	112,337.54	110,154.37	139,847.32	(24,991.46)	49,289.02	69,162.33				
40														
41														
42														
43		Budgeted												
44														
45	% of FY26 Budget Collected		74.72%											
46	FY26 Budgeted Amount		21,000,000											
47														
48		TOTAL YTD %	July	August	September	October	November	December	January	February	March	April	May	June
49	2025-26	74.716%	8.971%	9.002%	9.250%	9.211%	9.092%	9.190%	9.269%	10.732%				

EXPENSE NARRATIVE FEBRUARY, 2026

71100399 – OTHER CONTRACTED SERVICES

\$ 573,234.25 to ETSU University School ; January Revenue Sharing

22,727.28 for CSH School-Based Counselors

2,835.00 for juvenile facility fees

71100449 – TEXTBOOKS

\$ 76,720.00 for Magma Math subscription renewal

71100499 – OTHER SUPPLIES

\$ 8,125.00 for 250 cases of copier paper

23,352.23 for Special Education classroom materials

71100722 – 002 – CTE ISM GRANT

\$ 7,495.00 for classroom equipment ; Gray

9,995.00 for classroom equipment ; Grandview

71300429 – INSTRUCTIONAL SUPPLIES

\$ 3,400.00 for virtual business site licenses ; DBHS CTE

71300429 – 002 – CTE ISM GRANT SUPPLIES

\$ 3,158.75 for Audio-Visual system ; West View

4,344.43 for classroom equipment and furniture ; Lamar

71300471 – 002 – SOFTWARE – ISM GRANT

\$ 3,800.00 for Level Up system renewal ; Ridgeview

71300730 – 002 – CTE ISM GRANT EQUIPMENT

- \$ 3,365.40 for hydroponics system ; Sulphur Springs
- 3,119.15 for classroom materials ; Lamar
- 6,487.00 for laminator ; Jonesborough Elementary
- 3,999.00 for embroidery unit ; Grandview
- 18,282.00 for solvent printer ; DBHS
- 31,584.23 for audio visual system; West View

72130499 – OTHER SUPPLIES

- \$ 5,363.36 for annual Shoe Day expenses (reimbursed by the United Way)

72130524 – 002 – INSERVICE/STAFF DEVELOPMENT – CTE ISM GRANT

- \$ 4,181.29 for conference lodging
- 3,608.83 for conference expenses
- 6,680.00 for conference registrations

72210524 – INSERVICE/STAFF DEVELOPMENT

- \$ 2,882.64 for conference lodging
- 1,551.80 for conference expenses
- 5,645.00 for conference registrations
- 64,500.00 for Education Elements annual renewal

72220524 – INSERVICE/STAFF DEVELOPMENT

- \$ 6,846.00 for Special Education Professional Development/Webinar fees

72250350 – INTERNET CONNECTIVITY

- \$ 5,139.00 for monthly access fee

72250399 – OTHER CONTRACTED SERVICES

\$ 23,370.00 for Thrillshare Rooms Subscription

72250499 – OTHER SUPPLIES

\$ 3,829.14 for fourteen computer units ; system wide stock

3,700.66 for ten printers ; system wide stock

15,236.26 for technology department toner and materials ; system wide

72310399 – OTHER CONTRACTED SERVICES

\$ 4,249.45 to Lewis Group Architects ; security upgrades

6,018.49 to Lewis Group Architects ; DBHS HVAC upgrades

3,000.00 to TSBA for annual BOE Connect fee

72320399 – OTHER CONTRACTED SERVICES

\$ 12,561.88 for system wide copier leases

2,510.86 for Form 1095 processing fees

72610499 – OTHER SUPPLIES

\$ 7,350.00 for system wide ball field maintenance materials

72620335 – 0013 – SULPHUR SPRINGS – MAINTENANCE & REPAIRS, BUILDING

\$ 9,999.99 for gymnasium wall padding

72620336 – 0007 – FALL BRANCH – MAINTENANCE & REPAIRS, EQUIPMENT

\$ 10,993.50 for two HVAC units

72620336 – 0011 – LAMAR – MAINTENANCE & REPAIRS, EQUIPMENT

\$ 8,944.48 for water heater unit

72620336 – 0025 – RIDGEVIEW – MAINTENANCE & REPAIRS, EQUIPMENT

\$ 4,773.17 for HVAC unit compressor

72620399 – 004 – OTHER CONTRACTED SERVICES

\$ 98,600.00 for safety fencing ; Ridgeview, DCHS, South Central, and Asbury

72620499 – OTHER SUPPLIES

\$ 7,031.50 for electrical maintenance supplies

2,898.78 for HVAC maintenance supplies

5,261.69 for plumbing maintenance supplies

16,611.98 for grounds maintenance supplies

7,699.12 for general maintenance supplies

72710729 – TRANSPORTATION EQUIPMENT

\$ 2,981.09 for Ex-Mark mower leases

99100590 – TRANSFERS TO OTHER FUNDS

\$ 28,241.00 for EESI Loan Repayment # 45

		CHECK CHECK					
FND	ACCT	OBJ	PRJ	NUMBER	DATE	VENDOR	AMOUNT
141	71300	429	000	141235785	02/04/2026	BANK CARD	408.43
141	72130	524	000	141235785	02/04/2026	BANK CARD	4,885.88
141	72210	524	000	141235786	02/04/2026	BANKCARD	7,674.10
141	72310	599	000	141235786	02/04/2026	BANKCARD	267.54
141	72250	399	000	141235786	02/04/2026	BANKCARD	72.00
141	72310	331	000	141235787	02/04/2026	BENNETT & DECAMP PLL	4,500.00
141	72130	524	000	141235788	02/04/2026	DRINNON, BROOKE	71.31
141	72130	524	000	141235789	02/04/2026	LEWIS, CHRISTIE	215.00
141	72710	412	000	141235790	02/04/2026	MCPHERSON FLEETCARD	19,389.25
141	72710	425	000	141235790	02/04/2026	MCPHERSON FLEETCARD	9,979.40
141	72310	399	000	141235791	02/04/2026	TENN SCHOOL BOARDS A	3,000.00
141	72620	499	000	141235792	02/06/2026	AIRGAS INC, SOUTH DI	72.36
141	72620	499	000	141235792	02/06/2026	AIRGAS INC, SOUTH DI	31.48
141	72710	424	000	141235793	02/06/2026	ATCO INTERNATIONAL	362.84
141	72510	355	000	141235794	02/06/2026	AYERS, TAMMY	20.30
141	72710	453	000	141235795	02/06/2026	B & H SALES	383.00
141	72210	432	000	141235796	02/06/2026	BARNES & NOBLE INC	664.79
141	72620	499	000	141235797	02/06/2026	BATTERIES PLUS LLC	158.34
141	72120	355	000	141235798	02/06/2026	BEDERIAN, SHAWNA	262.45
141	72710	450	000	141235799	02/06/2026	BEST ONE TIRE	4,382.55
141	72510	355	000	141235800	02/06/2026	BLACK, CONNIE	47.13
141	72610	434	000	141235801	02/06/2026	BLOSSMAN GAS & APPLI	7,590.43
141	72610	434	000	141235801	02/06/2026	BLOSSMAN GAS & APPLI	4,147.23
141	72610	434	000	141235801	02/06/2026	BLOSSMAN GAS & APPLI	1,865.25
141	72710	442	000	141235801	02/06/2026	BLOSSMAN GAS & APPLI	8,754.83
141	72610	599	000	141235802	02/06/2026	BRIGHTSPEED	125.02
141	72510	355	000	141235803	02/06/2026	BUXTON, MELISSA	126.88
141	71100	299	000	141235804	02/06/2026	CHAPMAN, SARA	135.00
141	72210	355	000	141235805	02/06/2026	CHRISTIAN, AARON	116.00
141	72510	355	000	141235806	02/06/2026	CHURCH, ANGELA	46.40
141	72320	399	000	141235807	02/06/2026	COMCAST	162.73
141	72320	399	000	141235807	02/06/2026	COMCAST	118.87
141	72710	599	000	141235808	02/06/2026	CRAWFORD, LYDIA	99.15
141	72120	355	000	141235809	02/06/2026	DEBUSK, SYDNEE	165.30
141	72710	207	000	141235810	02/06/2026	DIRECT HEALTH CARE	300.00
141	72620	499	000	141235811	02/06/2026	DOWN TO EARTH	519.75
141	72620	499	000	141235811	02/06/2026	DOWN TO EARTH	553.50
141	72130	524	000	141235812	02/06/2026	EAN SERVICES LLC	659.75
141	72620	599	000	141235813	02/06/2026	EAST TENN RENT-ALLS	1,356.99
141	71200	599	000	141235814	02/06/2026	ETSU OFFICE OF PD	2,400.00
141	72620	499	000	141235815	02/06/2026	FENCO SUPPLY	2,898.78
141	72620	399	000	141235817	02/06/2026	FOSTER SIGNS	375.00
141	72620	399	000	141235817	02/06/2026	FOSTER SIGNS	335.00
141	72210	355	000	141235818	02/06/2026	FOUTCH, CHERIE	30.45
141	72620	499	000	141235819	02/06/2026	GOOD COMPANY	708.00
141	72110	355	000	141235820	02/06/2026	GRAY, SHANNON	236.35
141	71300	429	000	141235821	02/06/2026	GRIMCO INC	434.12
141	71300	429	000	141235821	02/06/2026	GRIMCO INC	18.88
141	71300	429	000	141235821	02/06/2026	GRIMCO INC	62.94
141	72510	355	000	141235822	02/06/2026	HACKETT, BARBARA	142.10
141	72230	355	000	141235823	02/06/2026	HAULDREN, KELLI	435.00
141	72230	355	000	141235823	02/06/2026	HAULDREN, KELLI	175.00
141	72120	355	000	141235824	02/06/2026	JACKSON, KRISTEN	100.05
141	71100	299	000	141235825	02/06/2026	JOHNSON, JENNIFER	135.00
141	72610	454	000	141235826	02/06/2026	JOHNSON CITY UTILITY	455.07
141	72610	454	000	141235826	02/06/2026	JOHNSON CITY UTILITY	22.87

Conference Lodging & Expenses; CTE DSM
Conference Lodging & Expenses

Diesel Fuel
Gasoline
BCE Connect

Tires for fleet vehicles

PROPANE

HVAC Mtna Materials

		CHECK CHECK					
<u>END</u>	<u>ACCT</u>	<u>OBJ</u>	<u>PRJ</u>	<u>NUMBER</u>	<u>DATE</u>	<u>VENDOR</u>	<u>AMOUNT</u>
141	72610	454	000	141235826	02/06/2026	JOHNSON CITY UTILITY	1,145.84
141	72610	454	000	141235826	02/06/2026	JOHNSON CITY UTILITY	10.54
141	72510	355	000	141235827	02/06/2026	KILIAN, KIMBERLY	101.50
141	72210	355	000	141235828	02/06/2026	LEWIS, TERESA	141.38
141	72510	355	000	141235829	02/06/2026	MASTERS, PAUL	34.08
141	72610	399	000	141235830	02/06/2026	MCCLAIN'S PEST CONTR	50.00
141	72120	355	000	141235831	02/06/2026	MEADE, MEAGAN	105.13
141	72710	453	000	141235832	02/06/2026	MID-SOUTH BUS CENTER	3,859.13
141	72510	499	000	141235833	02/06/2026	NELCO	794.74
141	71100	299	000	141235834	02/06/2026	NORTON, KAREN	135.00
141	72210	432	000	141235835	02/06/2026	PERMA-BOUND	187.41
141	72210	432	000	141235835	02/06/2026	PERMA-BOUND	1,492.13
141	72210	432	000	141235835	02/06/2026	PERMA-BOUND	509.16
141	72320	355	000	141235836	02/06/2026	RIVERS, KIM	34.80
141	72310	599	000	141235836	02/06/2026	RIVERS, KIM	295.78
141	72120	355	000	141235837	02/06/2026	SALYER, WENDI	89.18
141	72620	499	000	141235838	02/06/2026	SITE ONE LANDSCAPE S	3,819.49
141	72610	399	000	141235839	02/06/2026	STATE OF TENNESSEE	60.00
141	72210	524	000	141235840	02/06/2026	STEPP, WILLIAM	435.00
141	72210	524	000	141235840	02/06/2026	STEPP, WILLIAM	435.00
141	72510	355	000	141235841	02/06/2026	STEVENS, MICHELLE	7.98
141	72320	435	000	141235843	02/06/2026	TENNESSEE OFFICE SUP	196.43
141	71100	429	000	141235843	02/06/2026	TENNESSEE OFFICE SUP	1,300.00
141	71100	499	000	141235843	02/06/2026	TENNESSEE OFFICE SUP	8,125.00
141	71100	429	000	141235844	02/06/2026	THEMES & VARIATIONS	200.00
141	72120	355	000	141235845	02/06/2026	TIPTON, CLANCI	215.33
141	72620	499	000	141235846	02/06/2026	TMS SOUTH	178.14
141	72610	454	000	141235847	02/06/2026	TOWN OF JONESBOROUGH	38.00
141	72610	454	000	141235847	02/06/2026	TOWN OF JONESBOROUGH	133.59
141	72610	454	000	141235847	02/06/2026	TOWN OF JONESBOROUGH	1,757.10
141	72250	350	000	141235848	02/06/2026	UNITED DATA TECHNOLO	5,139.00
141	72710	412	000	141235849	02/06/2026	WADE, TERRY	173.72
141	72120	355	000	141235850	02/06/2026	WAGNER, KELLY	85.55
141	72320	355	000	141235851	02/09/2026	BOYD, JERRY	335.00
141	72320	355	000	141235851	02/09/2026	BOYD, JERRY	435.00
141	72410	355	000	141235852	02/09/2026	KITE, JOSH	277.68
141	72310	355	000	141235853	02/10/2026	BARNES, ERIC	435.00
141	72310	355	000	141235853	02/10/2026	BARNES, ERIC	210.00
141	72320	355	000	141235854	02/10/2026	BOYD, JERRY	135.00
141	72320	355	000	141235854	02/10/2026	BOYD, JERRY	350.18
141	72310	355	000	141235855	02/10/2026	BUCHANAN, ANNETTE	210.00
141	72310	355	000	141235855	02/10/2026	BUCHANAN, ANNETTE	435.00
141	72310	355	000	141235856	02/10/2026	FLEENOR, CHAD	435.00
141	72310	355	000	141235856	02/10/2026	FLEENOR, CHAD	210.00
141	72310	355	000	141235857	02/10/2026	HAMMOND, DAVID	210.00
141	72310	355	000	141235857	02/10/2026	HAMMOND, DAVID	435.00
141	72310	355	000	141235858	02/10/2026	MASTERS, MIKE	435.00
141	72310	355	000	141235858	02/10/2026	MASTERS, MIKE	135.00
141	72310	355	000	141235859	02/10/2026	WALTERS, VINCE	210.00
141	72310	355	000	141235859	02/10/2026	WALTERS, VINCE	435.00
141	71100	299	000	141235866	02/11/2026	OMNI GROUP	100.00
141	71100	299	000	141235867	02/11/2026	TASC	400.00
141	71300	730	000	141235884	02/12/2026	AIRMARK	6,487.00
141	71200	429	000	141235885	02/12/2026	AMAZON CAPITAL SERVI	39.99
141	71200	429	000	141235885	02/12/2026	AMAZON CAPITAL SERVI	57.02
141	71300	429	000	141235885	02/12/2026	AMAZON CAPITAL SERVI	12.59

Vehicle Parts

Grounds Int'l Materials

250 cases of copy paper

Internet Connectivity

Laminator ; JES, CTE ISM

		CHECK CHECK						
FND	ACCT	OBJ	PRJ	NUMBER	DATE	VENDOR		AMOUNT
141	71100	429	000	141235885	02/12/2026	AMAZON CAPITAL SERVI		26.79
141	71100	429	000	141235885	02/12/2026	AMAZON CAPITAL SERVI		15.28
141	71100	429	000	141235885	02/12/2026	AMAZON CAPITAL SERVI		37.28
141	71100	429	000	141235885	02/12/2026	AMAZON CAPITAL SERVI		265.17
141	71100	429	000	141235885	02/12/2026	AMAZON CAPITAL SERVI		89.65
141	71100	429	000	141235885	02/12/2026	AMAZON CAPITAL SERVI		149.36
141	71100	429	000	141235885	02/12/2026	AMAZON CAPITAL SERVI		104.11
141	71100	429	000	141235885	02/12/2026	AMAZON CAPITAL SERVI		154.11
141	71100	429	000	141235885	02/12/2026	AMAZON CAPITAL SERVI		39.96
141	71100	429	000	141235885	02/12/2026	AMAZON CAPITAL SERVI		19.99
141	71100	429	000	141235885	02/12/2026	AMAZON CAPITAL SERVI		277.58
141	71100	429	000	141235885	02/12/2026	AMAZON CAPITAL SERVI		255.06
141	71100	429	000	141235885	02/12/2026	AMAZON CAPITAL SERVI		118.66
141	71100	429	000	141235885	02/12/2026	AMAZON CAPITAL SERVI		180.46
141	72210	432	000	141235885	02/12/2026	AMAZON CAPITAL SERVI		172.60
141	72210	432	000	141235885	02/12/2026	AMAZON CAPITAL SERVI		2,147.26
141	71100	429	000	141235885	02/12/2026	AMAZON CAPITAL SERVI		157.87
141	71100	429	000	141235885	02/12/2026	AMAZON CAPITAL SERVI		18.60
141	71100	429	000	141235885	02/12/2026	AMAZON CAPITAL SERVI		296.87
141	71100	429	000	141235885	02/12/2026	AMAZON CAPITAL SERVI		297.36
141	71100	429	000	141235885	02/12/2026	AMAZON CAPITAL SERVI		297.37
141	71100	429	000	141235885	02/12/2026	AMAZON CAPITAL SERVI		52.49
141	71100	429	000	141235885	02/12/2026	AMAZON CAPITAL SERVI		239.89
141	71100	429	000	141235885	02/12/2026	AMAZON CAPITAL SERVI		207.60
141	71100	429	000	141235885	02/12/2026	AMAZON CAPITAL SERVI		237.04
141	72620	499	000	141235885	02/12/2026	AMAZON CAPITAL SERVI		47.98
141	72250	499	000	141235886	02/12/2026	AMAZON CAPITAL SERVI		118.71
141	72250	499	000	141235886	02/12/2026	AMAZON CAPITAL SERVI		105.70
141	72250	499	000	141235886	02/12/2026	AMAZON CAPITAL SERVI		1,296.00
141	72250	499	000	141235886	02/12/2026	AMAZON CAPITAL SERVI		57.75
141	72250	499	000	141235886	02/12/2026	AMAZON CAPITAL SERVI		189.85
141	72250	499	000	141235886	02/12/2026	AMAZON CAPITAL SERVI		2,243.61
141	71300	730	000	141235886	02/12/2026	AMAZON CAPITAL SERVI		3,999.00
141	71100	722	000	141235886	02/12/2026	AMAZON CAPITAL SERVI		489.49
141	71300	429	000	141235886	02/12/2026	AMAZON CAPITAL SERVI		71.98
141	73300	499	000	141235887	02/12/2026	AMERICAN RED CROSS		42.00
141	72620	499	000	141235888	02/12/2026	ANDY OXY CO INC		97.48
141	72250	399	000	141235889	02/12/2026	APPTEGY INC		23,370.00
141	72220	524	000	141235890	02/12/2026	ARC NETWORK LLC		1,800.00
141	72220	355	000	141235891	02/12/2026	BOWMAN, JEREMY		125.43
141	72620	499	000	141235892	02/12/2026	BSN SPORTS		1,961.83
141	71100	399	000	141235893	02/12/2026	CADAS INC		945.00
141	72210	355	000	141235894	02/12/2026	CALDERWOOD, TAMARA		31.18
141	72610	399	000	141235895	02/12/2026	CES CORPORATION		156.50
141	72610	399	000	141235895	02/12/2026	CES CORPORATION		490.00
141	72610	454	000	141235896	02/12/2026	CHUCKEY UTILITY DIST		356.82
141	72610	599	000	141235897	02/12/2026	CINTAS		513.68
141	72610	599	000	141235897	02/12/2026	CINTAS		316.25
141	72620	499	000	141235898	02/12/2026	CITY ELECTRIC SUPPLY		1,511.43
141	72610	454	000	141235899	02/12/2026	CITY OF KINGSPORT		255.17
141	72620	499	000	141235900	02/12/2026	CLINE-HOLDER ELECTRI		5,474.00
141	71100	499	000	141235901	02/12/2026	DANIEL BOONE HIGH SC		185.68
141	71100	499	000	141235902	02/12/2026	DAVID CROCKETT HIGH		213.16
141	71100	499	000	141235903	02/12/2026	DCHS CTE CULINARY DE		600.00
141	72220	355	000	141235904	02/12/2026	DUNCAN, CYNTHIA		48.58
141	71200	599	000	141235905	02/12/2026	ETSU OFFICE OF PD		2,400.00

Embroidery Unit; Grandview, CTE ISM

Thrillshare Rooms

Electrical Mtnc Materials

		CHECK CHECK					
END	ACCT	OBJ	PRJ	NUMBER	DATE	VENDOR	AMOUNT
141	72620	499	000	141235906	02/12/2026	FERGUSON ENTERPRISES	3,208.22
141	72610	399	000	141235907	02/12/2026	FLEENOR SECURITY SYS	39.99
141	72610	399	000	141235907	02/12/2026	FLEENOR SECURITY SYS	59.98
141	72610	399	000	141235907	02/12/2026	FLEENOR SECURITY SYS	84.99
141	72610	399	000	141235907	02/12/2026	FLEENOR SECURITY SYS	179.94
141	72610	399	000	141235907	02/12/2026	FLEENOR SECURITY SYS	84.99
141	72610	399	000	141235907	02/12/2026	FLEENOR SECURITY SYS	29.99
141	72610	399	000	141235907	02/12/2026	FLEENOR SECURITY SYS	25.00
141	72610	399	000	141235907	02/12/2026	FLEENOR SECURITY SYS	84.99
141	72610	399	000	141235907	02/12/2026	FLEENOR SECURITY SYS	37.01
141	72610	399	000	141235907	02/12/2026	FLEENOR SECURITY SYS	88.99
141	72610	399	000	141235907	02/12/2026	FLEENOR SECURITY SYS	29.99
141	72610	399	000	141235907	02/12/2026	FLEENOR SECURITY SYS	447.50
141	72610	399	000	141235907	02/12/2026	FLEENOR SECURITY SYS	593.73
141	72710	453	000	141235908	02/12/2026	FLEET EFORCE	4,801.85
141	72120	599	000	141235909	02/12/2026	FOOD CITY	44.87
141	72210	524	000	141235909	02/12/2026	FOOD CITY	168.11
141	71100	399	000	141235910	02/12/2026	FRONTIER HEALTH	22,727.28
141	71300	730	000	141235911	02/12/2026	GOVCONNECTION, INC	677.93
141	71300	730	000	141235911	02/12/2026	GOVCONNECTION, INC	-99.86
141	71300	429	000	141235912	02/12/2026	GRIMCO INC	130.57
141	72230	355	000	141235913	02/12/2026	HAULDREN, KELLI	196.48
141	72610	328	000	141235914	02/12/2026	HES FACILITIES	17,680.24
141	72610	328	000	141235914	02/12/2026	HES FACILITIES	11,512.72
141	72610	328	000	141235914	02/12/2026	HES FACILITIES	6,578.69
141	72610	328	000	141235914	02/12/2026	HES FACILITIES	10,690.38
141	72610	328	000	141235914	02/12/2026	HES FACILITIES	17,675.35
141	72610	328	000	141235914	02/12/2026	HES FACILITIES	9,868.03
141	72610	328	000	141235914	02/12/2026	HES FACILITIES	7,812.21
141	72610	328	000	141235914	02/12/2026	HES FACILITIES	8,223.37
141	72610	328	000	141235914	02/12/2026	HES FACILITIES	7,812.21
141	72610	328	000	141235914	02/12/2026	HES FACILITIES	18,913.75
141	72610	328	000	141235914	02/12/2026	HES FACILITIES	18,913.75
141	72610	328	000	141235914	02/12/2026	HES FACILITIES	11,512.72
141	72250	399	000	141235915	02/12/2026	INSIGHT PUBLIC SECTO	459.28
141	72220	355	000	141235916	02/12/2026	JOHNSON, AMY	166.03
141	71100	399	000	141235917	02/12/2026	LANGUAGE TRAINING CE	5.94
141	72210	355	000	141235918	02/12/2026	LEONARD, JILL	46.20
141	72310	599	000	141235919	02/12/2026	LOWE'S	230.40
141	72620	499	000	141235919	02/12/2026	LOWE'S	3,681.43
141	71300	429	000	141235919	02/12/2026	LOWE'S	159.33
141	72620	499	000	141235920	02/12/2026	MEADE TRACTOR	479.60
141	72210	355	000	141235921	02/12/2026	MILLER, JESSICA	129.05
141	71300	429	000	141235922	02/12/2026	NORTHEAST STATE	60.00
141	72250	499	000	141235923	02/12/2026	ODP BUSINESS SOLUTIO	630.38
141	72250	499	000	141235923	02/12/2026	ODP BUSINESS SOLUTIO	71.80
141	72250	499	000	141235923	02/12/2026	ODP BUSINESS SOLUTIO	678.68
141	72250	499	000	141235923	02/12/2026	ODP BUSINESS SOLUTIO	932.90
141	72250	499	000	141235923	02/12/2026	ODP BUSINESS SOLUTIO	876.26
141	72250	499	000	141235923	02/12/2026	ODP BUSINESS SOLUTIO	470.94
141	72250	499	000	141235923	02/12/2026	ODP BUSINESS SOLUTIO	69.48
141	72250	499	000	141235923	02/12/2026	ODP BUSINESS SOLUTIO	566.08
141	72250	499	000	141235923	02/12/2026	ODP BUSINESS SOLUTIO	291.30
141	72250	499	000	141235923	02/12/2026	ODP BUSINESS SOLUTIO	376.56
141	72250	499	000	141235923	02/12/2026	ODP BUSINESS SOLUTIO	375.64
141	72250	499	000	141235923	02/12/2026	ODP BUSINESS SOLUTIO	89.24

Plumbing Mtnc Materials

Electric Bus Parts

CSH Behavioral Counselors

Custodial Services

Mtnc Dept Materials

		CHECK CHECK					
FND	ACCT	OBJ	FRJ	NUMBER	DATE	VENDOR	AMOUNT
141	72250	499	000	141235923	02/12/2026	ODP BUSINESS Solutio	277.62
141	72620	499	000	141235923	02/12/2026	ODP BUSINESS Solutio	611.65
141	72210	432	000	141235924	02/12/2026	PERMA-BOUND	2,416.52
141	72210	432	000	141235924	02/12/2026	PERMA-BOUND	156.70
141	72130	524	000	141235925	02/12/2026	PIE CONSULTING	110.00
141	72130	524	000	141235925	02/12/2026	PIE CONSULTING	110.00
141	72130	524	000	141235925	02/12/2026	PIE CONSULTING	110.00
141	72130	524	000	141235925	02/12/2026	PIE CONSULTING	110.00
141	72130	524	000	141235925	02/12/2026	PIE CONSULTING	110.00
141	72130	524	000	141235925	02/12/2026	PIE CONSULTING	110.00
141	72210	355	000	141235926	02/12/2026	POORE, TAYLOR	43.50
141	72710	453	000	141235927	02/12/2026	PRO BILLING & FUNDIN	674.25
141	72320	399	000	141235928	02/12/2026	RLI	350.00
141	71300	730	000	141235929	02/12/2026	ROBERT J. YOUNG COMP	18,282.00
141	72130	524	000	141235930	02/12/2026	ROSENBAUM, KELLY	105.00
141	72210	355	000	141235931	02/12/2026	SANDERS, MEGAN	92.80
141	71300	730	000	141235932	02/12/2026	SCHOOL SPECIALTY LLC	3,119.15
141	72220	355	000	141235933	02/12/2026	SELF, LEA	179.80
141	72250	499	000	141235934	02/12/2026	SHIELDS ELECTRONICS	1,095.00
141	72220	355	000	141235935	02/12/2026	ST JOHN, SEBRENA	92.80
141	71300	429	000	141235936	02/12/2026	TCAT ELIZABETHTON	820.20
141	72620	499	000	141235937	02/12/2026	TMS SOUTH	519.27
141	72220	355	000	141235938	02/12/2026	TRAINOR, THEVA	39.15
141	72620	499	000	141235939	02/12/2026	TRI CITY MOWER & SAW	400.00
141	72320	307	000	141235940	02/12/2026	UNITED DATA TECHNOLO	238.25
141	72320	307	000	141235940	02/12/2026	UNITED DATA TECHNOLO	347.13
141	72320	307	000	141235940	02/12/2026	UNITED DATA TECHNOLO	315.96
141	72320	307	000	141235940	02/12/2026	UNITED DATA TECHNOLO	130.54
141	72320	307	000	141235940	02/12/2026	UNITED DATA TECHNOLO	204.08
141	72320	307	000	141235940	02/12/2026	UNITED DATA TECHNOLO	161.49
141	72320	307	000	141235940	02/12/2026	UNITED DATA TECHNOLO	26.85
141	72320	307	000	141235940	02/12/2026	UNITED DATA TECHNOLO	151.18
141	72320	307	000	141235940	02/12/2026	UNITED DATA TECHNOLO	147.86
141	72320	307	000	141235940	02/12/2026	UNITED DATA TECHNOLO	233.84
141	72320	307	000	141235940	02/12/2026	UNITED DATA TECHNOLO	517.10
141	72320	307	000	141235940	02/12/2026	UNITED DATA TECHNOLO	242.96
141	72320	307	000	141235940	02/12/2026	UNITED DATA TECHNOLO	130.85
141	72320	307	000	141235940	02/12/2026	UNITED DATA TECHNOLO	151.08
141	72320	307	000	141235940	02/12/2026	UNITED DATA TECHNOLO	257.38
141	72320	307	000	141235940	02/12/2026	UNITED DATA TECHNOLO	158.79
141	72710	307	000	141235940	02/12/2026	UNITED DATA TECHNOLO	19.14
141	72620	307	000	141235940	02/12/2026	UNITED DATA TECHNOLO	107.39
141	73300	599	000	141235940	02/12/2026	UNITED DATA TECHNOLO	50.01
141	72620	336	000	141235941	02/12/2026	UNITED REFRIGERATION	4,773.17
141	72320	307	000	141235942	02/12/2026	VERIZON WIRELESS	43.73
141	72320	307	000	141235942	02/12/2026	VERIZON WIRELESS	2,004.90
141	71300	429	000	141235943	02/12/2026	VEX ROBOTICS	772.78
141	72610	166	000	141235944	02/12/2026	WASHINGTON COUNTY FO	798.38
141	72610	399	000	141235945	02/12/2026	WATER SOLUTIONS ENGI	1,230.00
141	72610	410	000	141235946	02/12/2026	WEBB CHEMICAL & PAPE	439.72
141	72610	410	000	141235946	02/12/2026	WEBB CHEMICAL & PAPE	914.59
141	72610	410	000	141235946	02/12/2026	WEBB CHEMICAL & PAPE	180.14
141	72610	410	000	141235946	02/12/2026	WEBB CHEMICAL & PAPE	1,613.19
141	72610	410	000	141235946	02/12/2026	WEBB CHEMICAL & PAPE	497.40
141	72610	410	000	141235946	02/12/2026	WEBB CHEMICAL & PAPE	2,014.03
141	72610	410	000	141235946	02/12/2026	WEBB CHEMICAL & PAPE	843.56
141	72610	410	000	141235946	02/12/2026	WEBB CHEMICAL & PAPE	3,520.14

Solvent Printer; DHS CTE ISM

Classroom Materials; Lamar CTE ISM

HVAC unit compressor; Ridgeview

Custodial Supplies

CHECK CHECK							
FND	ACCT	OBJ	PRJ	NUMBER	DATE	VENDOR	AMOUNT
141	72610	410	000	141235946	02/12/2026	WEBB CHEMICAL & PAPE	513.00
141	72610	410	000	141235946	02/12/2026	WEBB CHEMICAL & PAPE	1,167.67
141	72610	410	000	141235946	02/12/2026	WEBB CHEMICAL & PAPE	410.31
141	72610	410	000	141235946	02/12/2026	WEBB CHEMICAL & PAPE	895.23
141	72210	355	000	141235947	02/12/2026	ZUEHLKE, JAN	229.10
141	72320	399	000	141235948	02/13/2026	AMERICAN BENEFIT ADM	200.00
141	71100	722	000	141235949	02/13/2026	APPLE INC	1,645.00
141	71300	429	000	141235949	02/13/2026	APPLE INC	119.00
141	72620	399	000	141235950	02/13/2026	ESKOLA LLC	719.40
141	72220	524	000	141235951	02/13/2026	EVERWAY LLC	6,846.00
141	71100	499	000	141235951	02/13/2026	EVERWAY LLC	20,485.58
141	71100	499	000	141235951	02/13/2026	EVERWAY LLC	2,866.35
141	71300	429	000	141235952	02/13/2026	GRIMCO INC	606.00
141	72130	524	000	141235953	02/13/2026	PIE CONSULTING	110.00
141	72130	524	000	141235953	02/13/2026	PIE CONSULTING	110.00
141	72320	399	000	141235954	02/13/2026	ROBERT J. YOUNG COMP	12,561.88
141	71300	730	000	141235955	02/13/2026	SKYLINE PRINT	1,447.00
141	71100	399	000	141235956	02/13/2026	VILLAGE BEHAVIORAL H	945.00
141	71100	399	000	141235956	02/13/2026	VILLAGE BEHAVIORAL H	945.00
141	72620	499	000	141235957	02/13/2026	WASHINGTON FARMERS C	3,271.57
141	72210	355	000	141235961	02/20/2026	ADAMS, JARROD	246.50
141	72710	453	000	141235962	02/20/2026	ADVANCE AUTO PARTS	8,065.64
141	71300	429	000	141235963	02/20/2026	AIRGAS INC, SOUTH DI	32.17
141	71300	429	000	141235963	02/20/2026	AIRGAS INC, SOUTH DI	174.00
141	71300	429	000	141235964	02/20/2026	AMBROSOUND	3,158.75
141	71300	730	000	141235964	02/20/2026	AMBROSOUND	31,584.23
141	72620	335	000	141235965	02/20/2026	ATLAS GREENHOUSE LLC	1,960.00
141	72610	434	000	141235966	02/20/2026	ATMOS ENERGY	1,152.08
141	72610	434	000	141235966	02/20/2026	ATMOS ENERGY	1,097.70
141	72610	434	000	141235966	02/20/2026	ATMOS ENERGY	741.72
141	72610	434	000	141235966	02/20/2026	ATMOS ENERGY	1,426.00
141	72610	434	000	141235966	02/20/2026	ATMOS ENERGY	1,727.61
141	72610	434	000	141235966	02/20/2026	ATMOS ENERGY	8,740.63
141	72610	434	000	141235966	02/20/2026	ATMOS ENERGY	7,912.26
141	72610	434	000	141235966	02/20/2026	ATMOS ENERGY	5,919.43
141	72320	399	000	141235967	02/20/2026	BHMA OCCUPATIONAL ME	45.00
141	72320	399	000	141235967	02/20/2026	BHMA OCCUPATIONAL ME	45.00
141	72320	399	000	141235968	02/20/2026	BLUE RIDGE DOCUMENT	100.00
141	72610	415	000	141235969	02/20/2026	BRIGHT RIDGE	9,269.17
141	72610	415	000	141235969	02/20/2026	BRIGHT RIDGE	4,789.65
141	72610	415	000	141235969	02/20/2026	BRIGHT RIDGE	3,828.17
141	72610	415	000	141235969	02/20/2026	BRIGHT RIDGE	14,626.30
141	72610	415	000	141235969	02/20/2026	BRIGHT RIDGE	16,076.38
141	72610	415	000	141235969	02/20/2026	BRIGHT RIDGE	5,785.25
141	72610	415	000	141235969	02/20/2026	BRIGHT RIDGE	10,761.16
141	72610	415	000	141235969	02/20/2026	BRIGHT RIDGE	8,716.47
141	72610	415	000	141235969	02/20/2026	BRIGHT RIDGE	2,645.25
141	72610	415	000	141235969	02/20/2026	BRIGHT RIDGE	12,539.29
141	72610	415	000	141235969	02/20/2026	BRIGHT RIDGE	7,437.07
141	72610	415	000	141235969	02/20/2026	BRIGHT RIDGE	10,345.60
141	72610	415	000	141235969	02/20/2026	BRIGHT RIDGE	13,807.86
141	72610	415	000	141235969	02/20/2026	BRIGHT RIDGE	32,798.98
141	72610	415	000	141235969	02/20/2026	BRIGHT RIDGE	35,193.35
141	72610	415	000	141235969	02/20/2026	BRIGHT RIDGE	17,739.92
141	72320	307	000	141235970	02/20/2026	BRIGHTSPEED	27.99
141	72220	355	000	141235971	02/20/2026	CAMPBELL, AMANDA	198.80

PTD & Webinar; SpEd
Classroom Materials; SpEd

Copier Leases; Systemwide

Grounds Maintenance Materials

Vehicle Parts

Audio-Visual System; West View CTE ISM

NATURAL GAS

		CHECK CHECK					
FND	ACCT	OBJ	PRJ	NUMBER	DATE	VENDOR	AMOUNT
141	72220	355	000	141235971	02/20/2026	CAMPBELL, AMANDA	223.30
141	72220	355	000	141235972	02/20/2026	CHAPMAN, JOHANNA	176.90
141	72220	355	000	141235973	02/20/2026	CHITTUM, ROB	296.53
141	72610	599	000	141235974	02/20/2026	CINTAS	804.68
141	72610	599	000	141235974	02/20/2026	CINTAS	130.60
141	71300	429	000	141235975	02/20/2026	CREXO INC	794.25
141	71300	730	000	141235975	02/20/2026	CREXO INC	2,348.00
141	72230	355	000	141235976	02/20/2026	DBHS HEALTH SCIENCE	4,089.00
141	72230	355	000	141235977	02/20/2026	DBHS SKILLS USA	2,407.00
141	72230	355	000	141235978	02/20/2026	DCHS HEALTH SCIENCE	2,323.00
141	72230	355	000	141235979	02/20/2026	DCHS SKILLS USA	4,097.00
141	72210	432	000	141235980	02/20/2026	DEMCO	2,438.21
141	72210	432	000	141235980	02/20/2026	DEMCO	2,438.21
141	72210	432	000	141235980	02/20/2026	DEMCO	320.15
141	72230	355	000	141235981	02/20/2026	DRINNON, SHANNON	29.00
141	71300	429	000	141235982	02/20/2026	EDYNAMIC LP	3,400.00
141	72620	399	000	141235983	02/20/2026	ES DOCKERY, INC	565.00
141	71100	399	000	141235984	02/20/2026	ETSU UNIVERSITY SCHO	573,234.25
141	72710	599	000	141235985	02/20/2026	FAST SIGNS	60.31
141	72610	399	000	141235986	02/20/2026	FLEENOR SECURITY SYS	37.01
141	72610	399	000	141235986	02/20/2026	FLEENOR SECURITY SYS	84.99
141	72210	336	000	141235987	02/20/2026	FOLLETT SOFTWARE, LL	452.11
141	71300	429	000	141235988	02/20/2026	FOOD CITY	1,100.00
141	72210	355	000	141235989	02/20/2026	GARST, JOHNATHAN	105.85
141	71300	429	000	141235990	02/20/2026	GRIMCO INC	224.99
141	71300	429	000	141235990	02/20/2026	GRIMCO INC	61.00
141	71300	429	000	141235990	02/20/2026	GRIMCO INC	24.25
141	72210	432	000	141235991	02/20/2026	GUMDROP BOOKS	3,042.26
141	72620	336	000	141235992	02/20/2026	HAJOCA CORPORATION	8,944.48
141	72230	355	000	141235993	02/20/2026	HALE, CHARLES	213.15
141	71300	730	000	141235994	02/20/2026	HARVEST RIGHT	1,795.00
141	71300	429	000	141235995	02/20/2026	HEADMASTER LLP	169.85
141	72210	355	000	141235996	02/20/2026	HOLLEY, PRESTON	234.90
141	72620	399	000	141235997	02/20/2026	KINGS DEVELOPMENT GR	98,600.00
141	72610	399	000	141235998	02/20/2026	LEO'S PEST CONTROL	1,316.50
141	72130	524	000	141235999	02/20/2026	LEWIS, CHRISTIE	145.00
141	72610	599	000	141236000	02/20/2026	LYONS, KIM	58.00
141	72620	499	000	141236001	02/20/2026	MARTIN MARIETTA MATE	5,606.24
141	72130	524	000	141236002	02/20/2026	MURRAY, KIRSTEN	145.00
141	72130	524	000	141236003	02/20/2026	NC3	495.00
141	72130	524	000	141236004	02/20/2026	O'NEAL, DIANA	145.00
141	72250	499	000	141236005	02/20/2026	ODP BUSINESS SOLUTIO	278.33
141	72250	499	000	141236005	02/20/2026	ODP BUSINESS SOLUTIO	87.52
141	72250	499	000	141236005	02/20/2026	ODP BUSINESS SOLUTIO	341.79
141	71100	429	000	141236005	02/20/2026	ODP BUSINESS SOLUTIO	9.39
141	71100	429	000	141236005	02/20/2026	ODP BUSINESS SOLUTIO	118.55
141	71100	429	000	141236005	02/20/2026	ODP BUSINESS SOLUTIO	23.26
141	71100	429	000	141236005	02/20/2026	ODP BUSINESS SOLUTIO	576.23
141	71100	429	000	141236005	02/20/2026	ODP BUSINESS SOLUTIO	21.33
141	71100	429	000	141236005	02/20/2026	ODP BUSINESS SOLUTIO	13.78
141	71100	429	000	141236005	02/20/2026	ODP BUSINESS SOLUTIO	14.34
141	71300	471	000	141236006	02/20/2026	PAXTON/PATTERSON	3,800.00
141	71100	722	000	141236006	02/20/2026	PAXTON/PATTERSON	2,450.55
141	72520	355	000	141236007	02/20/2026	PERCELL, CINDY	123.25
141	72210	432	000	141236008	02/20/2026	PERMA-BOUND	141.48
141	72130	524	000	141236009	02/20/2026	PERRY, RACHEL	145.00

State conference expenses

Business Site Licenses; DBHS CTE

Revenue Sharing; January

Library Books; GRAY

Plumbing mtnc Materials

Security Fencing; RV, DCHS, SC, Asbury

Stone Products; Grounds Dept

Level Up System; Ridgeview CTE ISM

		CHECK CHECK					
FND	ACCT	OBJ	PRJ	NUMBER	DATE	VENDOR	AMOUNT
141	72320	348	000	141236010	02/20/2026	PITNEY BOWES PURCHAS	2,108.87
141	72320	348	000	141236011	02/20/2026	PITNEY BOWES INC	522.04
141	72320	399	000	141236012	02/20/2026	PRIMO BRANDS	373.41
141	72410	499	000	141236013	02/20/2026	QUILL LLC	66.96
141	71100	429	000	141236013	02/20/2026	QUILL LLC	7.44
141	71100	429	000	141236013	02/20/2026	QUILL LLC	495.86
141	71100	429	000	141236013	02/20/2026	QUILL LLC	23.99
141	71100	429	000	141236013	02/20/2026	QUILL LLC	14.60
141	71100	429	000	141236013	02/20/2026	QUILL LLC	15.72
141	71100	429	000	141236013	02/20/2026	QUILL LLC	7.25
141	71300	730	000	141236014	02/20/2026	REALITYWORKS	3,365.40
141	71100	429	000	141236015	02/20/2026	SCHOOL SPECIALTY LLC	524.20
141	72130	524	000	141236016	02/20/2026	SHELTON, HEATHER	145.00
141	72220	399	000	141236017	02/20/2026	SIDEKICK THERAPY PAR	328.40
141	72620	399	000	141236018	02/20/2026	SNYDER SIGNS	1,566.57
141	72620	335	000	141236019	02/20/2026	SOLAR RESPONSE, LLC	636.00
141	72210	524	000	141236020	02/20/2026	SULPHUR SPRINGS SCHO	1,368.00
141	72620	599	000	141236021	02/20/2026	TEG ENTERPRISES	105.00
141	72310	599	000	141236022	02/20/2026	TENN SCHOOL BOARDS A	350.00
141	71300	730	000	141236023	02/20/2026	THE CERAMIC SHOP	988.19
141	71300	730	000	141236023	02/20/2026	THE CERAMIC SHOP	482.59
141	72220	355	000	141236024	02/20/2026	THOMPSON, LESLIE	189.23
141	72620	499	000	141236025	02/20/2026	TMS SOUTH	415.66
141	72610	359	000	141236026	02/20/2026	TOWN OF JONESBOROUGH	125.00
141	72610	454	000	141236026	02/20/2026	TOWN OF JONESBOROUGH	75.79
141	72620	336	000	141236027	02/20/2026	TRANE COMPANY	10,993.50
141	72710	453	000	141236028	02/20/2026	TRUCK PRO	4,875.71
141	99100	590	000	141236029	02/20/2026	WASHINGTON COUNTY DEBT	28,241.00
141	71300	429	000	141236030	02/20/2026	WESTEL GREENHOUSE, L	292.49
141	72130	524	000	141236031	02/20/2026	WIDNER, DONNA	145.00
141	72210	355	000	141236047	02/25/2026	ADAMS, JARROD	300.00
141	72210	355	000	141236047	02/25/2026	ADAMS, JARROD	400.20
141	72210	355	000	141236047	02/25/2026	ADAMS, JARROD	210.00
141	72310	599	000	141236048	02/25/2026	BANK CARD	320.33
141	72320	399	000	141236048	02/25/2026	BANK CARD	2,510.86
141	72520	499	000	141236048	02/25/2026	BANK CARD	299.00
141	72120	524	000	141236048	02/25/2026	BANK CARD	2,765.83
141	71300	429	000	141236049	02/25/2026	BANKCARD	411.50
141	72230	355	000	141236049	02/25/2026	BANKCARD	812.64
141	71300	429	000	141236049	02/25/2026	BANKCARD	739.92
141	72130	524	000	141236049	02/25/2026	BANKCARD	1,253.00
141	72320	355	000	141236050	02/25/2026	BOYD, JERRY	70.00
141	72320	355	000	141236050	02/25/2026	BOYD, JERRY	435.00
141	72610	599	000	141236051	02/25/2026	CINTAS	319.76
141	72620	599	000	141236051	02/25/2026	CINTAS	2,163.70
141	72710	599	000	141236051	02/25/2026	CINTAS	750.20
141	72610	599	000	141236051	02/25/2026	CINTAS	404.64
141	72610	599	000	141236051	02/25/2026	CINTAS	145.00
141	72610	599	000	141236051	02/25/2026	CINTAS	290.92
141	72210	355	000	141236053	02/25/2026	GRAY, SHANNON	225.00
141	72610	454	000	141236054	02/25/2026	JOHNSON CITY UTILITY	4,913.27
141	72610	454	000	141236054	02/25/2026	JOHNSON CITY UTILITY	1,852.00
141	72610	454	000	141236054	02/25/2026	JOHNSON CITY UTILITY	3,569.84
141	72610	359	000	141236054	02/25/2026	JOHNSON CITY UTILITY	183.26
141	72610	359	000	141236054	02/25/2026	JOHNSON CITY UTILITY	1,043.00
141	72610	359	000	141236054	02/25/2026	JOHNSON CITY UTILITY	963.00

Hydroponics System; Sulphur Springs CTE ISM

*Two HVAC Units; Fall Branch
Vehicle Parts
EESI Loan Payment # 45*

*Form 1095 Processing
Conference Expenses*

		CHECK CHECK					
FND	ACCT	OBJ	PRJ	NUMBER	DATE	VENDOR	AMOUNT
141	72610	359	000	141236054	02/25/2026	JOHNSON CITY UTILITY	150.00
141	72610	359	000	141236054	02/25/2026	JOHNSON CITY UTILITY	440.00
141	72610	359	000	141236054	02/25/2026	JOHNSON CITY UTILITY	275.00
141	72610	359	000	141236054	02/25/2026	JOHNSON CITY UTILITY	275.00
141	72610	359	000	141236054	02/25/2026	JOHNSON CITY UTILITY	420.00
141	72610	359	000	141236054	02/25/2026	JOHNSON CITY UTILITY	156.38
141	72610	359	000	141236054	02/25/2026	JOHNSON CITY UTILITY	210.14
141	72610	359	000	141236054	02/25/2026	JOHNSON CITY UTILITY	151.85
141	72610	359	000	141236054	02/25/2026	JOHNSON CITY UTILITY	59.05
141	72610	359	000	141236054	02/25/2026	JOHNSON CITY UTILITY	174.34
141	72610	454	000	141236054	02/25/2026	JOHNSON CITY UTILITY	775.69
141	72610	454	000	141236054	02/25/2026	JOHNSON CITY UTILITY	461.33
141	72610	454	000	141236054	02/25/2026	JOHNSON CITY UTILITY	42.60
141	72610	359	000	141236054	02/25/2026	JOHNSON CITY UTILITY	7,545.00
141	72520	355	000	141236055	02/25/2026	PERCELL, CINDY	75.00
141	72520	355	000	141236055	02/25/2026	PERCELL, CINDY	142.10
141	72210	524	000	141236055	02/25/2026	PERCELL, CINDY	150.00
141	72210	524	000	141236055	02/25/2026	PERCELL, CINDY	411.80
141	72520	355	000	141236055	02/25/2026	PERCELL, CINDY	284.20
141	72520	355	000	141236055	02/25/2026	PERCELL, CINDY	150.00
141	71100	449	000	141236056	02/25/2026	RADISH EDUCATION INC	76,720.00 <i>Magma Math Subscription</i>
141	72120	499	000	141236057	02/25/2026	SALYER, WENDI	225.00
141	72210	355	000	141236058	02/25/2026	STEPP, WILLIAM	570.00
141	72120	499	000	141236059	02/25/2026	TIPTON, CLANCI	225.00
141	72610	454	000	141236060	02/25/2026	TOWN OF JONESBOROUGH	38.00
141	72610	454	000	141236060	02/25/2026	TOWN OF JONESBOROUGH	438.77
141	72610	454	000	141236060	02/25/2026	TOWN OF JONESBOROUGH	247.69
141	72610	359	000	141236060	02/25/2026	TOWN OF JONESBOROUGH	125.00
141	72610	454	000	141236060	02/25/2026	TOWN OF JONESBOROUGH	76.61
141	72610	359	000	141236060	02/25/2026	TOWN OF JONESBOROUGH	375.00
141	72610	454	000	141236060	02/25/2026	TOWN OF JONESBOROUGH	79.09
141	72610	454	000	141236060	02/25/2026	TOWN OF JONESBOROUGH	50.13
141	72610	454	000	141236060	02/25/2026	TOWN OF JONESBOROUGH	50.13
141	72610	454	000	141236060	02/25/2026	TOWN OF JONESBOROUGH	808.85
141	72610	359	000	141236060	02/25/2026	TOWN OF JONESBOROUGH	750.00
141	72610	454	000	141236060	02/25/2026	TOWN OF JONESBOROUGH	23.00
141	72610	454	000	141236060	02/25/2026	TOWN OF JONESBOROUGH	25.10
141	72610	454	000	141236060	02/25/2026	TOWN OF JONESBOROUGH	306.82
141	72610	454	000	141236060	02/25/2026	TOWN OF JONESBOROUGH	244.03
141	72120	499	000	141236062	02/25/2026	WAGNER, KELLY	225.00
141	72710	599	000	141236063	02/25/2026	WESTERN EQUIPMENT FI	2,981.09 <i>Ex-Mark Mauer Leases</i>
141	72520	355	000	141236064	02/25/2026	WHITAKER, JERRY	142.10
141	72520	355	000	141236064	02/25/2026	WHITAKER, JERRY	75.00
141	72210	524	000	141236064	02/25/2026	WHITAKER, JERRY	120.00
141	72210	524	000	141236065	02/25/2026	XANEDU PUBLISHING IN	64,500.00 <i>Education Elements</i>
141	72710	599	000	141236066	02/27/2026	AAA AUTO GLASS	100.00
141	72710	599	000	141236067	02/27/2026	ACE AUTO GLASS	395.00
141	72210	524	000	141236068	02/27/2026	AMAZON CAPITAL SERVI	200.98
141	72210	524	000	141236068	02/27/2026	AMAZON CAPITAL SERVI	16.85
141	71200	429	000	141236068	02/27/2026	AMAZON CAPITAL SERVI	93.73
141	71200	429	000	141236068	02/27/2026	AMAZON CAPITAL SERVI	45.96
141	71300	429	000	141236068	02/27/2026	AMAZON CAPITAL SERVI	728.16
141	71300	429	000	141236068	02/27/2026	AMAZON CAPITAL SERVI	194.63
141	71300	429	000	141236068	02/27/2026	AMAZON CAPITAL SERVI	323.46
141	72320	435	000	141236068	02/27/2026	AMAZON CAPITAL SERVI	69.98
141	72320	435	000	141236068	02/27/2026	AMAZON CAPITAL SERVI	43.50

		CHECK CHECK					
FND	ACCT	OBJ	PRJ	NUMBER	DATE	VENDOR	AMOUNT
141	73400	499	000	141236068	02/27/2026	AMAZON CAPITAL SERVI	364.11
141	72210	432	000	141236068	02/27/2026	AMAZON CAPITAL SERVI	31.20
141	72210	432	000	141236068	02/27/2026	AMAZON CAPITAL SERVI	1,844.28
141	72210	432	000	141236068	02/27/2026	AMAZON CAPITAL SERVI	53.98
141	72210	432	000	141236068	02/27/2026	AMAZON CAPITAL SERVI	59.16
141	72210	432	000	141236068	02/27/2026	AMAZON CAPITAL SERVI	74.50
141	72250	499	000	141236068	02/27/2026	AMAZON CAPITAL SERVI	2,302.77
141	72250	499	000	141236068	02/27/2026	AMAZON CAPITAL SERVI	208.32
141	72250	499	000	141236068	02/27/2026	AMAZON CAPITAL SERVI	129.00
141	72250	499	000	141236068	02/27/2026	AMAZON CAPITAL SERVI	79.75
141	72250	499	000	141236068	02/27/2026	AMAZON CAPITAL SERVI	192.40
141	71100	722	000	141236068	02/27/2026	AMAZON CAPITAL SERVI	499.00
141	71300	429	000	141236068	02/27/2026	AMAZON CAPITAL SERVI	4,344.43
141	71300	429	000	141236068	02/27/2026	AMAZON CAPITAL SERVI	58.06
141	71300	429	000	141236068	02/27/2026	AMAZON CAPITAL SERVI	1,480.05
141	71300	429	000	141236068	02/27/2026	AMAZON CAPITAL SERVI	879.47
141	71300	429	000	141236068	02/27/2026	AMAZON CAPITAL SERVI	205.29
141	71300	429	000	141236068	02/27/2026	AMAZON CAPITAL SERVI	1,311.98
141	71100	722	000	141236068	02/27/2026	AMAZON CAPITAL SERVI	366.59
141	71300	429	000	141236068	02/27/2026	AMAZON CAPITAL SERVI	175.13
141	71300	429	000	141236068	02/27/2026	AMAZON CAPITAL SERVI	22.95
141	71300	429	000	141236068	02/27/2026	AMAZON CAPITAL SERVI	47.98
141	72610	499	000	141236071	02/27/2026	AMERICAN SPORTS FIEL	7,350.00
141	72620	499	000	141236072	02/27/2026	AMERICAN FLOOR MATS	1,685.29
141	71300	429	000	141236073	02/27/2026	APPLIED AMERICAN LAB	1,355.00
141	71100	722	000	141236073	02/27/2026	APPLIED AMERICAN LAB	7,495.00
141	71300	429	000	141236074	02/27/2026	BANKCARD	1,521.20
141	71300	730	000	141236074	02/27/2026	BANKCARD	2,464.00
141	72620	499	000	141236075	02/27/2026	BATTERIES PLUS LLC	191.28
141	72620	499	000	141236075	02/27/2026	BATTERIES PLUS LLC	459.90
141	71100	299	000	141236076	02/27/2026	BEDERIAN, SHAWNA	93.31
141	72210	355	000	141236077	02/27/2026	BOWDEN, MARY	78.88
141	72620	335	000	141236078	02/27/2026	BSN SPORTS	9,999.00
141	72620	399	000	141236079	02/27/2026	CES CORPORATION	1,219.00
141	72610	599	000	141236080	02/27/2026	CINTAS	253.00
141	72230	355	000	141236081	02/27/2026	DCHS FCCLA	2,354.00
141	72230	355	000	141236082	02/27/2026	DCHS FFA	1,857.00
141	72620	599	000	141236083	02/27/2026	DCHS WELDING DEPT	100.00
141	72710	599	000	141236084	02/27/2026	DIRECT HEALTH CARE	1,630.00
141	72250	399	000	141236086	02/27/2026	FREUND RESOURCES	455.00
141	71300	730	000	141236087	02/27/2026	GOVCONNECTION, INC	134.96
141	72250	499	000	141236087	02/27/2026	GOVCONNECTION, INC	3,829.14
141	72250	499	000	141236087	02/27/2026	GOVCONNECTION, INC	3,700.66
141	72250	499	000	141236087	02/27/2026	GOVCONNECTION, INC	491.85
141	72210	355	000	141236088	02/27/2026	GRANT, BRYON	159.50
141	71100	299	000	141236089	02/27/2026	HAMPTON, ALIESHA	135.00
141	72210	524	000	141236090	02/27/2026	HILL, DENISE	105.00
141	72210	524	000	141236090	02/27/2026	HILL, DENISE	435.00
141	72320	399	000	141236091	02/27/2026	INSTRUCTURE INC	300.00
141	72710	146	000	141236092	02/27/2026	LAMAR SCHOOL	161.35
141	72210	355	000	141236093	02/27/2026	LEONARD, JILL	25.38
141	72210	355	000	141236093	02/27/2026	LEONARD, JILL	64.53
141	72210	355	000	141236093	02/27/2026	LEONARD, JILL	37.80
141	72310	399	000	141236094	02/27/2026	LEWIS GROUP ARCHITEC	159.20
141	72310	399	000	141236094	02/27/2026	LEWIS GROUP ARCHITEC	3,777.75
141	72310	399	000	141236094	02/27/2026	LEWIS GROUP ARCHITEC	6,018.49

Classroom equipment & furniture; Lamar CTE ISM

Grounds mtace Materials

Classroom equipment; Gray CTE ISM

Gymnasium wall padding; Sulphur Springs

*14 computers; stock
10 printers; stock*

*Security upgrades
DBHS HVAC upgrades*

		CHECK CHECK					
FND	ACCT	OBJ	PRJ	NUMBER	DATE	VENDOR	AMOUNT
141	72310	399	000	141236094	02/27/2026	LEWIS GROUP ARCHITEC	312.50
141	72610	399	000	141236095	02/27/2026	MCCLAIN'S PEST CONTR	50.00
141	72130	524	000	141236096	02/27/2026	MILLER, ANTHONY	31.61
141	72210	524	000	141236097	02/27/2026	MILLER, JESSICA	105.00
141	72250	499	000	141236098	02/27/2026	ODP BUSINESS SOLUTIO	311.03
141	71100	206	000	141236099	02/27/2026	AMERICAN UNITED LIFE	1,500.00
141	71100	299	000	141236099	02/27/2026	AMERICAN UNITED LIFE	3,166.83
141	71200	206	000	141236099	02/27/2026	AMERICAN UNITED LIFE	281.00
141	71300	206	000	141236099	02/27/2026	AMERICAN UNITED LIFE	130.50
141	72110	206	000	141236099	02/27/2026	AMERICAN UNITED LIFE	4.40
141	72120	206	000	141236099	02/27/2026	AMERICAN UNITED LIFE	44.30
141	72130	206	000	141236099	02/27/2026	AMERICAN UNITED LIFE	77.80
141	72210	206	000	141236099	02/27/2026	AMERICAN UNITED LIFE	92.10
141	72230	206	000	141236099	02/27/2026	AMERICAN UNITED LIFE	6.10
141	72320	206	000	141236099	02/27/2026	AMERICAN UNITED LIFE	17.40
141	72410	206	000	141236099	02/27/2026	AMERICAN UNITED LIFE	179.50
141	72510	206	000	141236099	02/27/2026	AMERICAN UNITED LIFE	6.00
141	72610	206	000	141236099	02/27/2026	AMERICAN UNITED LIFE	69.50
141	72620	206	000	141236099	02/27/2026	AMERICAN UNITED LIFE	28.10
141	72710	206	000	141236099	02/27/2026	AMERICAN UNITED LIFE	151.70
141	72810	206	000	141236099	02/27/2026	AMERICAN UNITED LIFE	7.60
141	72250	206	000	141236099	02/27/2026	AMERICAN UNITED LIFE	47.90
141	71100	299	000	141236100	02/27/2026	PHILLIPS, MICHELLE	135.00
141	72130	524	000	141236101	02/27/2026	PIE CONSULTING	110.00
141	72710	399	000	141236102	02/27/2026	PONDER AUTO REPAIR	224.83
141	72610	399	000	141236103	02/27/2026	PREMIER FIRE PROTECT	700.00
141	72520	355	000	141236104	02/27/2026	RIDDLE, HEATHER	75.00
141	72520	355	000	141236104	02/27/2026	RIDDLE, HEATHER	142.10
141	72120	599	000	141236105	02/27/2026	RUBBER STAMP CHAMP.C	108.00
141	72310	599	000	141236106	02/27/2026	SAM'S CLUB DIRECT	119.45
141	71100	429	000	141236107	02/27/2026	SAM'S CLUB MC/SYNCB	193.50
141	71100	429	000	141236107	02/27/2026	SAM'S CLUB MC/SYNCB	87.00
141	72130	524	000	141236108	02/27/2026	SHELTON, HEATHER	187.05
141	72120	599	000	141236109	02/27/2026	SHOE CARNIVAL INC	5,363.36
141	72210	355	000	141236110	02/27/2026	SMITH, ALICE ANN	93.53
141	72130	524	000	141236111	02/27/2026	SPHERO INC	200.00
141	71300	429	000	141236112	02/27/2026	STEMFINITY LLC	190.96
141	71300	730	000	141236112	02/27/2026	STEMFINITY LLC	619.00
141	72320	399	000	141236113	02/27/2026	TENN BUREAU OF INVES	650.00
141	72210	524	000	141236114	02/27/2026	TENN SCHOOL BOARDS A	2,500.00
141	72210	524	000	141236114	02/27/2026	TENN SCHOOL BOARDS A	2,500.00
141	71100	722	000	141236115	02/27/2026	THE MAGIC TOUCH USA	9,995.00
141	72210	524	000	141236116	02/27/2026	TIAAA	180.00
141	72620	499	000	141236117	02/27/2026	TMS SOUTH	940.40
141	72130	524	000	141236119	02/27/2026	WIDNER, DONNA	151.52

Board provided life insurance

Shoe Day

Conference registrations

Classroom equipment; Grandview CTE ISM

Totals for checks 1,861,710.16

FUND SUMMARY

<u>FUND</u>	<u>DESCRIPTION</u>	<u>BALANCE SHEET</u>	<u>REVENUE</u>	<u>EXPENSE</u>	<u>TOTAL</u>
141	GENERAL PURPOSE SCHOOL	0.00	0.00	1,861,710.16	1,861,710.16
***	Fund Summary Totals ***	0.00	0.00	1,861,710.16	1,861,710.16

***** End of report *****

Account Level						2025-26	February 2025-26	2025-26	Encumbered	Unexpended	2025-26
Fnd T Acct	Obj Prj Loc	Prg	Description	Budget	Monthly Activity	FYTD Activity	Amount	Balance - YTD Act	FYTD %		
71100	REGULAR INSTRUCTION										
141 E 71100 429 000 00000 300	ESTU SLICE GRANT					0.00	0.00	0.00	0.00	0.00	0.00
141 E 71100 429 000 00002 000	INSTRUCTIONAL SUPPLIES-ASBURY					0.00	0.00	3,229.72	0.00	-3,229.72	0.00
141 E 71100 429 000 00003 000	INSTRUCTIONAL SUPPLIES-MIDWAY					0.00	0.00	0.00	0.00	0.00	0.00
141 E 71100 429 000 00004 000	INSTRUCTIONAL SUPPLIES-BCES					0.00	1,370.52	16,162.74	0.00	-16,162.74	0.00
141 E 71100 429 000 00005 000	INSTRUCTIONAL SUPPLIES-BCMS					0.00	0.00	0.00	0.00	0.00	0.00
141 E 71100 429 000 00006 000	INSTRUCTIONAL SUPPLIES-GVES					0.00	0.00	19,170.76	0.00	-19,170.76	0.00
141 E 71100 429 000 00007 000	INSTRUCTIONAL SUPPLIES-FBES					0.00	0.00	9,900.08	0.00	-9,900.08	0.00
141 E 71100 429 000 00008 000	INSTRUCTIONAL SUPPLIES-GES					0.00	1,276.32	11,902.76	0.00	-11,902.76	0.00
141 E 71100 429 000 00009 000	INSTRUCTIONAL SUPPLIES-JES					0.00	0.00	22,136.51	0.00	-22,136.51	0.00
141 E 71100 429 000 00010 000	INSTRUCTIONAL SUPPLIES-JMS					0.00	0.00	0.00	0.00	0.00	0.00
141 E 71100 429 000 00011 000	INSTRUCTIONAL SUPPLIES-LES					0.00	280.50	13,421.54	0.00	-13,421.54	0.00
141 E 71100 429 000 00012 000	INSTRUCTIONAL SUPPLIES-SCES					0.00	200.00	5,943.97	0.00	-5,943.97	0.00
141 E 71100 429 000 00013 000	INSTRUCTIONAL SUPPLIES-SSES					0.00	0.00	13,210.88	0.00	-13,210.88	0.00
141 E 71100 429 000 00014 000	INSTRUCTIONAL SUPPLIES-WVES					0.00	0.00	11,372.66	0.00	-11,372.66	0.00
141 E 71100 429 000 00015 000	INSTRUCTIONAL SUPPLIES-DBHS					0.00	1,300.00	19,233.61	0.00	-19,233.61	0.00
141 E 71100 429 000 00016 000	INSTRUCTIONAL SUPPLIES-DCHS					0.00	891.71	27,065.17	0.00	-27,065.17	0.00
141 E 71100 429 000 00025 000	INSTRUCTIONAL SUPPLIES-RVES					0.00	0.00	15,401.28	0.00	-15,401.28	0.00
141 E 71100 449 000 00000 000	TEXTBOOKS					1,200,000.00	76,720.00	228,836.60	0.00	971,163.40	19.07
141 E 71100 499 000 00000 000	OTHER SUPPLIES AND MATERIALS					583,000.00	32,076.93	160,104.57	0.00	422,895.43	27.46
141 E 71100 499 000 00000 002	CTE ISM GRANT					0.00	0.00	0.00	0.00	0.00	0.00
141 E 71100 499 000 00000 003	Supplies-Summer Learning					0.00	0.00	0.00	0.00	0.00	0.00
141 E 71100 499 000 00000 005	SUPPLIES-STEM GRANTS					0.00	0.00	0.00	0.00	0.00	0.00
141 E 71100 499 000 00000 100	OTHER SUPPLIES-CIVICS GRANT					0.00	0.00	0.00	0.00	0.00	0.00
141 E 71100 499 000 00000 200	GRANT FUNDS					0.00	0.00	0.00	0.00	0.00	0.00
141 E 71100 499 000 00000 300	ETSU SLICE-SIUPPLIES					0.00	0.00	0.00	0.00	0.00	0.00
141 E 71100 499 000 00000 802	INSTR. SCIENCE CLASS SUPPLIES					24,000.00	0.00	16,484.91	0.00	7,515.09	68.69
141 E 71100 499 000 00002 000	OTHER SUPPLIES & MAT.-ASBURY					0.00	0.00	0.00	0.00	0.00	0.00
141 E 71100 499 000 00003 000	OTHER SUPPLIES & MAT.-MIDWAY					0.00	0.00	0.00	0.00	0.00	0.00
141 E 71100 499 000 00004 000	OTHER SUPPLIES & MAT.-BCES					0.00	0.00	1,770.50	0.00	-1,770.50	0.00
141 E 71100 499 000 00005 000	OTHER SUPPLIES & MAT.-BCMS					0.00	0.00	0.00	0.00	0.00	0.00
141 E 71100 499 000 00006 000	OTHER SUPPLIES & MAT.-GVES					0.00	0.00	3,423.72	0.00	-3,423.72	0.00
141 E 71100 499 000 00007 000	OTHER SUPPLIES & MAT.-FBES					0.00	0.00	3,466.74	0.00	-3,466.74	0.00
141 E 71100 499 000 00008 000	OTHER SUPPLIES & MAT.-GES					0.00	0.00	2,500.00	0.00	-2,500.00	0.00
141 E 71100 499 000 00009 000	OTHER SUPPLIES & MAT.-JES					0.00	0.00	1,777.02	0.00	-1,777.02	0.00
141 E 71100 499 000 00010 000	OTHER SUPPLIES & MAT.-JMS					0.00	0.00	0.00	0.00	0.00	0.00
141 E 71100 499 000 00011 000	OTHER SUPPLIES & MAT.-LES					0.00	0.00	135.40	0.00	-135.40	0.00
141 E 71100 499 000 00012 000	OTHER SUPPLIES & MAT.-SCES					0.00	0.00	5,500.00	0.00	-5,500.00	0.00
141 E 71100 499 000 00013 000	OTHER SUPPLIES & MAT.-SSES					0.00	0.00	3,011.00	0.00	-3,011.00	0.00

Fnd T Acct	Obj Prj Loc	Prg Description	2025-26 Budget	February 2025-26 Monthly Activity	2025-26 FYTD Activity	Encumbered Amount	Unexpended Balance - YTD Act	2025-26 FYTD %
71100		REGULAR INSTRUCTION						
141 E 71100 499 000 00014 000		OTHER SUPPLIES & MAT.-WVES	0.00	0.00	283.78	0.00	-283.78	0.00
141 E 71100 499 000 00015 000		OTHER SUPPLIES & MAT.-DBHS	0.00	185.68	13,349.63	0.00	-13,349.63	0.00
141 E 71100 499 000 00016 000		OTHER SUPPLIES & MAT.-DCHS	0.00	213.16	9,227.32	0.00	-9,227.32	0.00
141 E 71100 499 000 00017 000		OTHER SUPPLIES & MAT-UH	0.00	0.00	0.00	0.00	0.00	0.00
141 E 71100 499 000 00025 000		OTHER SUPPLIES & MAT.-RVES	0.00	0.00	1,199.58	0.00	-1,199.58	0.00
141 E 71100 595 000 00000 000		JDC	0.00	0.00	0.00	0.00	0.00	0.00
141 E 71100 599 000 00000 000		OTHER CHARGES	124,573.13	0.00	0.00	0.00	124,573.13	0.00
141 E 71100 599 000 00000 003		Supplies-Summer Learning	0.00	0.00	0.00	0.00	0.00	0.00
141 E 71100 599 000 00000 025		OTHER CHARGES	0.00	0.00	0.00	0.00	0.00	0.00
141 E 71100 599 000 00002 000		ASBURY	932.19	0.00	0.00	0.00	932.19	0.00
141 E 71100 599 000 00004 000		BOONES CREEK ELEMENTARY	11,610.91	0.00	750.00	0.00	10,860.91	6.46
141 E 71100 599 000 00006 000		GRANDVIEW	7,439.27	0.00	0.00	0.00	7,439.27	0.00
141 E 71100 599 000 00007 000		FALL BRANCH	3,167.39	0.00	2,550.83	0.00	616.56	80.53
141 E 71100 599 000 00008 000		GRAY ELEMENTARY	7,261.84	0.00	0.00	0.00	7,261.84	0.00
141 E 71100 599 000 00009 000		JONESBOROUGH ELEMENTARY	14,312.13	0.00	14,200.00	0.00	112.13	99.22
141 E 71100 599 000 00011 000		LAMAR	4,429.01	0.00	2,993.76	0.00	1,435.25	67.59
141 E 71100 599 000 00012 000		SOUTH CENTRAL	1,910.86	0.00	2,951.25	0.00	-1,040.39	154.45
141 E 71100 599 000 00013 000		SULPHER SPRINGS	4,664.33	0.00	5,852.00	0.00	-1,187.67	125.46
141 E 71100 599 000 00014 000		WESTVIEW	2,552.74	0.00	4,284.40	0.00	-1,731.66	167.84
141 E 71100 599 000 00015 000		DANIEL BOONE HIGH	5,058.27	0.00	18,180.00	0.00	-13,121.73	359.41
141 E 71100 599 000 00016 000		DAVID CROCKETT HIGH	4,440.55	0.00	12,950.00	0.00	-8,509.45	291.63
141 E 71100 599 000 00017 000		UNIVERSITY SCHOOL-UH	7,572.21	0.00	0.00	0.00	7,572.21	0.00
141 E 71100 599 000 00025 000		RIDGEVIEW	10,075.17	0.00	5,583.60	0.00	4,491.57	55.42
141 E 71100 708 000 00000 000		COMMUNICATIONS EQUIPMENT	160,000.00	0.00	0.00	0.00	160,000.00	0.00
141 E 71100 722 000 00000 002		CTE ISM GRANT	0.00	22,940.63	117,070.84	0.00	-117,070.84	0.00
141 E 71100 --- --- ----- ---			51,988,174.00	4,349,843.76	28,137,033.75	0.00	23,851,140.25	54.12
71200		SPECIAL EDUCATION PROGRAM						
141 E 71200 116 000 00000 000		SP.ED. TEACHERS	3,437,144.00	281,267.85	1,715,322.57	0.00	1,721,821.43	49.91
141 E 71200 117 000 00000 000		CAREER LADDER PROGRAM	12,000.00	0.00	500.00	0.00	11,500.00	4.17
141 E 71200 128 000 00000 000		HOMEBOUND TEACHERS	20,400.00	0.00	0.00	0.00	20,400.00	0.00
141 E 71200 163 000 00000 000		EDUCATIONAL ASSISTANTS	1,261,937.00	102,934.95	640,803.27	0.00	621,133.73	50.78
141 E 71200 163 000 00000 912		EDUCATIONAL ASSISTANTS SPED PR	0.00	5,310.03	27,038.58	0.00	-27,038.58	0.00
141 E 71200 171 000 00000 000		SPEECH PATHOLOGIST	269,886.00	0.00	0.00	0.00	269,886.00	0.00

Fnd T	Acct	Obj	Prj	Loc	Prg	Account Level Description	2025-26 Budget	February 2025-26 Monthly Activity	2025-26 FYTD Activity	Encumbered Amount	Unexpended Balance - YTD Act	2025-26 FYTD %
71200						SPECIAL EDUCATION PROGRAM						
141 E	71200	188	000	00000	000	BONUS	0.00	0.00	112,000.00	0.00	-112,000.00	0.00
141 E	71200	189	000	00000	000	OTHER SALARIES	182,111.00	13,522.09	97,362.89	0.00	84,748.11	53.46
141 E	71200	195	000	00000	000	CERTIFIED SUBSTITUTE TEACHERS	20,000.00	0.00	0.00	0.00	20,000.00	0.00
141 E	71200	195	995	00000	000	WCDE RETIRED SUBSTITUTE TEACHE	0.00	0.00	0.00	0.00	0.00	0.00
141 E	71200	198	000	00000	000	NON-CERTIFIED SUBSTITUTE TEACH	65,000.00	0.00	0.00	0.00	65,000.00	0.00
141 E	71200	201	000	00000	000	SOCIAL SECURITY	326,646.00	23,027.54	149,834.33	0.00	176,811.67	45.87
141 E	71200	201	000	00000	912	SOCIAL SECURITY SPED PR	0.00	312.02	1,632.55	0.00	-1,632.55	0.00
141 E	71200	204	000	00000	000	STATE RETIREMENT	406,235.00	34,992.56	226,660.29	0.00	179,574.71	55.80
141 E	71200	204	000	00000	912	STATE RETIREMENT SPED PR	0.00	700.40	3,609.08	0.00	-3,609.08	0.00
141 E	71200	206	000	00000	000	LIFE INSURANCE	3,000.00	281.00	1,686.00	0.00	1,314.00	56.20
141 E	71200	207	000	00000	000	MEDICAL INSURANCE	720,230.00	101,286.08	566,476.15	0.00	153,753.85	78.65
141 E	71200	207	000	00000	912	MEDICAL INSURANCE SPED PR	0.00	0.00	0.00	0.00	0.00	0.00
141 E	71200	212	000	00000	000	EMPLOYER MEDICARE	76,393.00	5,385.49	35,041.94	0.00	41,351.06	45.87
141 E	71200	212	000	00000	912	MEDICARE SPED PR	0.00	72.97	381.80	0.00	-381.80	0.00
141 E	71200	299	000	00000	000	OTHER FRINGE BENEFITS	0.00	0.00	0.00	0.00	0.00	0.00
141 E	71200	399	000	00000	000	OTHER CONTRACTED SERVICES	0.00	0.00	0.00	0.00	0.00	0.00
141 E	71200	429	000	00000	000	INSTRUCTIONAL SUPPLIES & MATER	22,400.00	236.70	17,681.78	0.00	4,718.22	78.94
141 E	71200	429	000	00000	912	SUPPLIES AND MATERIALS SPED PR	0.00	0.00	0.00	0.00	0.00	0.00
141 E	71200	429	000	00002	000	INSTRUCTIONAL SUP. & MAT.-ASBU	0.00	0.00	0.00	0.00	0.00	0.00
141 E	71200	429	000	00003	000	INSTRUCTIONAL SUP. & MAT.-MIDW	0.00	0.00	0.00	0.00	0.00	0.00
141 E	71200	429	000	00004	000	INSTRUCTIONAL SUP. & MAT.-BCES	0.00	0.00	0.00	0.00	0.00	0.00
141 E	71200	429	000	00005	000	INSTRUCTIONAL SUP. & MAT.-BCMS	0.00	0.00	0.00	0.00	0.00	0.00
141 E	71200	429	000	00006	000	INSTRUCTIONAL SUP. & MAT.-GVES	0.00	0.00	0.00	0.00	0.00	0.00
141 E	71200	429	000	00007	000	INSTRUCTIONAL SUP. & MAT.-FBES	0.00	0.00	0.00	0.00	0.00	0.00
141 E	71200	429	000	00008	000	INSTRUCTIONAL SUP. & MAT.-GES	0.00	0.00	0.00	0.00	0.00	0.00
141 E	71200	429	000	00009	000	INSTRUCTIONAL SUP. & MAT.-JES	0.00	0.00	0.00	0.00	0.00	0.00
141 E	71200	429	000	00010	000	INSTRUCTIONAL SUP. & MAT.-JMS	0.00	0.00	0.00	0.00	0.00	0.00
141 E	71200	429	000	00011	000	INSTRUCTIONAL SUP. & MAT.-LES	0.00	0.00	0.00	0.00	0.00	0.00
141 E	71200	429	000	00012	000	INSTRUCTIONAL SUP. & MAT.-SCES	0.00	0.00	0.00	0.00	0.00	0.00
141 E	71200	429	000	00013	000	INSTRUCTIONAL SUP. & MAT.-SSES	0.00	0.00	0.00	0.00	0.00	0.00
141 E	71200	429	000	00014	000	INSTRUCTIONAL SUP. & MAT.-WVES	0.00	0.00	0.00	0.00	0.00	0.00
141 E	71200	429	000	00015	000	INSTRUCTIONAL SUP. & MAT.-DBHS	0.00	0.00	0.00	0.00	0.00	0.00
141 E	71200	429	000	00016	000	INSTRUCTIONAL SUP. & MAT.-DCHS	0.00	0.00	0.00	0.00	0.00	0.00
141 E	71200	429	000	00025	000	INSTRUCTIONAL SUP. & MAT.-RVES	0.00	0.00	0.00	0.00	0.00	0.00
141 E	71200	499	000	00000	000	OTHER SUPPLIES AND MATERIALS	0.00	0.00	6,377.10	0.00	-6,377.10	0.00
141 E	71200	499	000	00000	912	OTHER SUPPLIES SPED PR	0.00	0.00	0.00	0.00	0.00	0.00
141 E	71200	595	000	00000	000	INDIVIDUALIZED EDU. ACCOUNT	0.00	0.00	0.00	0.00	0.00	0.00
141 E	71200	599	000	00000	000	OTHER CHARGES	0.00	4,800.00	4,800.00	0.00	-4,800.00	0.00

Fnd T	Acct	Obj	Prj	Loc	Prg	Account Level Description	2025-26 Budget	February 2025-26 Monthly Activity	2025-26 FYTD Activity	Encumbered Amount	Unexpended Balance - YTD Act	2025-26 FYTD %
71300 VOCATIONAL EDUCATION PROGRAM												
141 E	71300	730	000	00025	000	VOCATIONAL INSTR EQUIP-RVES	0.00	0.00	0.00	0.00	0.00	0.00
141 E	71300	---	---	-----	---		4,108,093.00	444,220.56	2,606,791.05	0.00	1,501,301.95	63.46
71600 ADULT EDUCATION PROGRAM												
141 E	71600	116	000	00000	000	AD. ED. TEACHERS	0.00	0.00	0.00	0.00	0.00	0.00
141 E	71600	201	000	00000	000	SOCIAL SECURITY	0.00	0.00	0.00	0.00	0.00	0.00
141 E	71600	204	000	00000	000	STATE RETIREMENT	0.00	0.00	0.00	0.00	0.00	0.00
141 E	71600	212	000	00000	000	EMPLOYER MEDICARE	0.00	0.00	0.00	0.00	0.00	0.00
141 E	71600	429	000	00000	000	INSTRUCTIONAL SUPPLIES & MATER	0.00	0.00	0.00	0.00	0.00	0.00
141 E	71600	---	---	-----	---		0.00	0.00	0.00	0.00	0.00	0.00
71901 COVID-19 EXP. INSTRUCTION												
141 E	71901	499	000	00000	000	OTHER CHARGES AND MATERIALS	0.00	0.00	0.00	0.00	0.00	0.00
141 E	71901	---	---	-----	---		0.00	0.00	0.00	0.00	0.00	0.00
72110 ATTENDANCE PROGRAM												
141 E	72110	105	000	00000	000	SUPERVISOR/DIRECTOR	106,064.00	8,755.34	70,042.72	0.00	36,021.28	66.04
141 E	72110	117	000	00000	000	CAREER LADDER PROGRAM	1,000.00	0.00	0.00	0.00	1,000.00	0.00
141 E	72110	162	000	00000	000	CLERICAL PERSONNEL	46,904.00	3,842.84	30,742.72	0.00	16,161.28	65.54
141 E	72110	201	000	00000	000	SOCIAL SECURITY	9,546.00	718.18	5,881.10	0.00	3,664.90	61.61
141 E	72110	204	000	00000	000	STATE RETIREMENT	12,364.00	1,012.05	8,096.40	0.00	4,267.60	65.48
141 E	72110	206	000	00000	000	LIFE INSURANCE	50.00	4.40	26.40	0.00	23.60	52.80
141 E	72110	207	000	00000	000	MEDICAL INSURANCE	21,242.00	3,531.60	20,512.80	0.00	729.20	96.57
141 E	72110	212	000	00000	000	EMPLOYER MEDICARE	2,233.00	167.96	1,375.42	0.00	857.58	61.60
141 E	72110	299	000	00000	000	OTHER FRINGE BENEFITS	0.00	0.00	0.00	0.00	0.00	0.00
141 E	72110	355	000	00000	000	TRAVEL	2,000.00	236.35	1,816.05	0.00	183.95	90.80

Fnd T Acct	Obj Prj Loc	Prg	Account Level Description	2025-26 Budget	February 2025-26 Monthly Activity	2025-26 FYTD Activity	Encumbered Amount	Unexpended Balance - YTD Act	2025-26 FYTD %
72110 ATTENDANCE PROGRAM									
141 E 72110	499 000 000000	000	OTHER SUPPLIES AND MATERIALS	500.00	0.00	249.50	0.00	250.50	49.90
141 E 72110	499 000 000000	100	OTHER SUPPLIES & MATERIALS_D	0.00	0.00	0.00	0.00	0.00	0.00
141 E 72110	524 000 000000	000	IN-SERVICE / STAFF DEVELOPMENT	5,000.00	0.00	1,574.87	0.00	3,425.13	31.50
				<hr/>	<hr/>	<hr/>	<hr/>	<hr/>	<hr/>
141 E 72110	---	---	-----	206,903.00	18,268.72	140,317.98	0.00	66,585.02	67.82
				=====	=====	=====	=====	=====	=====
72120 HEALTH SERVICES									
141 E 72120	105 000 000000	000	SUPERVISOR/DIRECTOR	0.00	20,652.00	131,385.27	0.00	-131,385.27	0.00
141 E 72120	131 000 000000	000	MEDICAL PERSONNEL	368,403.00	45,966.41	285,631.76	0.00	82,771.24	77.53
141 E 72120	131 937 000000	000	MEDICAL PERSONNEL	0.00	0.00	0.00	0.00	0.00	0.00
141 E 72120	189 000 000000	000	OTHER SALARIES & WAGES	619,098.00	11,334.97	68,368.01	0.00	550,729.99	11.04
141 E 72120	201 000 000000	000	SOCIAL SECURITY	61,225.00	4,635.18	28,961.62	0.00	32,263.38	47.30
141 E 72120	204 000 000000	000	STATE RETIREMENT	130,251.00	7,907.67	50,836.27	0.00	79,414.73	39.03
141 E 72120	206 000 000000	000	LIFE INSURANCE	450.00	44.30	265.80	0.00	184.20	59.07
141 E 72120	207 000 000000	000	MEDICAL INSURANCE	198,906.00	14,927.60	77,892.40	0.00	121,013.60	39.16
141 E 72120	212 000 000000	000	EMPLOYER MEDICARE	14,319.00	1,084.03	6,773.18	0.00	7,545.82	47.30
141 E 72120	299 000 000000	000	OTHER FRINGE BENEFITS	0.00	0.00	0.00	0.00	0.00	0.00
141 E 72120	355 000 000000	000	TRAVEL	10,000.00	1,022.99	12,088.47	0.00	-2,088.47	120.88
141 E 72120	399 000 000000	000	OTHER CONTRACTED SERVICES	5,000.00	0.00	3,436.22	0.00	1,563.78	68.72
141 E 72120	399 000 000000	100	OTHER C & S - DONATION	0.00	0.00	0.00	0.00	0.00	0.00
141 E 72120	413 000 000000	000	DRUGS AND MEDICAL SUPPLIES	0.00	0.00	0.00	0.00	0.00	0.00
141 E 72120	499 000 000000	000	OTHER SUPPLIES AND MATERIALS	30,000.00	675.00	12,834.04	0.00	17,165.96	42.78
141 E 72120	499 999 000000	000	OTHER SUPPLIES-DONATIONS	0.00	0.00	0.00	0.00	0.00	0.00
141 E 72120	524 000 000000	000	IN-SERVICE / STAFF DEVELOPMENT	5,000.00	2,765.83	4,891.92	0.00	108.08	97.84
141 E 72120	599 000 000000	000	OTHER CHARGES	20,000.00	5,516.23	5,765.55	0.00	14,234.45	28.83
				<hr/>	<hr/>	<hr/>	<hr/>	<hr/>	<hr/>
141 E 72120	---	---	-----	1,462,652.00	116,532.21	689,130.51	0.00	773,521.49	47.12
				=====	=====	=====	=====	=====	=====
72130 OTHER STUDENT SUPPORT									
141 E 72130	117 000 000000	000	CAREER LADDER PROGRAM	2,000.00	0.00	500.00	0.00	1,500.00	25.00
141 E 72130	123 000 000000	000	GUIDANCE PERSONNEL	1,386,669.00	111,917.07	661,040.10	0.00	725,628.90	47.67
141 E 72130	123 000 000000	002	CTE ISM GRANT	0.00	0.00	13,210.19	0.00	-13,210.19	0.00

Account Level		2025-26	February 2025-26	2025-26	Encumbered	Unexpended	2025-26
Fnd T Acct	Obj Prj Loc Prg Description	Budget	Monthly Activity	FYTD Activity	Amount	Balance - YTD Act	FYTD %
72130	OTHER STUDENT SUPPORT						
141 E 72130 524 000 00000 002	CTE-ISM Grant	0.00	10,005.12	47,892.87	0.00	-47,892.87	0.00
141 E 72130 524 000 00000 150	IN-SERVICE / STAFF DEVELOPMENT	0.00	0.00	0.00	0.00	0.00	0.00
141 E 72130 790 000 00000 000	OTHER EQUIPMENT	28,000.00	0.00	133.99	0.00	27,866.01	0.48
141 E 72130 --- --- ----- ---		2,017,670.00	172,691.24	1,061,696.53	0.00	955,973.47	52.62
		=====	=====	=====	=====	=====	=====
72210	SUPPORT REGULAR INSTRUCTION						
141 E 72210 105 000 00000 000	SUPERVISOR/DIRECTOR	473,467.00	46,383.19	367,708.60	0.00	105,758.40	77.66
141 E 72210 105 003 00000 000	SUMMER PROGRAMS-LEARNING CAMPS	0.00	0.00	0.00	0.00	0.00	0.00
141 E 72210 117 000 00000 000	CAREER LADDER PROGRAM	0.00	0.00	0.00	0.00	0.00	0.00
141 E 72210 127 000 00000 000	CAREER LADDER EXTENDED CONTRAC	0.00	0.00	0.00	0.00	0.00	0.00
141 E 72210 129 000 00000 000	LIBRARIANS	868,703.00	66,161.13	396,966.78	0.00	471,736.22	45.70
141 E 72210 138 000 00000 000	TECHNOLOGY PERSONNEL	0.00	0.00	0.00	0.00	0.00	0.00
141 E 72210 162 000 00000 000	CLERICAL PERSONNEL	221,801.00	20,321.24	129,750.09	0.00	92,050.91	58.50
141 E 72210 189 000 00000 000	OTHER SALARIES & WAGES	0.00	0.00	0.00	0.00	0.00	0.00
141 E 72210 189 000 00000 010	OTHER SALARIES AND WAGES	0.00	0.00	0.00	0.00	0.00	0.00
141 E 72210 189 000 00000 011	OTHER SALARIES AND WAGES	0.00	0.00	0.00	0.00	0.00	0.00
141 E 72210 196 000 00000 000	IN-SERVICE TRAINING	0.00	0.00	0.00	0.00	0.00	0.00
141 E 72210 196 000 00000 011	IN SERVICE TRAINING	0.00	0.00	0.00	0.00	0.00	0.00
141 E 72210 201 000 00000 000	SOCIAL SECURITY	96,966.00	7,717.85	52,412.06	0.00	44,553.94	54.05
141 E 72210 201 000 00000 010	SOCIAL SECURITY	0.00	0.00	0.00	0.00	0.00	0.00
141 E 72210 201 000 00000 011	SOCIAL SECURITY	0.00	0.00	0.00	0.00	0.00	0.00
141 E 72210 201 003 00000 000		0.00	0.00	0.00	0.00	0.00	0.00
141 E 72210 204 000 00000 000	STATE RETIREMENT	106,699.00	9,469.12	63,084.70	0.00	43,614.30	59.12
141 E 72210 204 000 00000 010	STATE RETIREMENT	0.00	0.00	0.00	0.00	0.00	0.00
141 E 72210 204 000 00000 011	STATE RETIREMENT	0.00	0.00	0.00	0.00	0.00	0.00
141 E 72210 204 003 00000 000		0.00	0.00	0.00	0.00	0.00	0.00
141 E 72210 206 000 00000 000	LIFE INSURANCE	1,000.00	92.10	552.60	0.00	447.40	55.26
141 E 72210 207 000 00000 000	MEDICAL INSURANCE	223,105.00	25,311.30	149,011.20	0.00	74,093.80	66.79
141 E 72210 207 000 00000 010	MEDICAL INSURANCE	0.00	0.00	0.00	0.00	0.00	0.00
141 E 72210 207 000 00000 011	MEDICAL INSURANCE	0.00	0.00	0.00	0.00	0.00	0.00
141 E 72210 212 000 00000 000	EMPLOYER MEDICARE	22,678.00	1,804.99	12,257.72	0.00	10,420.28	54.05
141 E 72210 212 003 00000 000		0.00	0.00	0.00	0.00	0.00	0.00
141 E 72210 299 000 00000 000	OTHER FRINGE BENEFITS	0.00	0.00	0.00	0.00	0.00	0.00
141 E 72210 336 000 00000 000	MAINTENANCE AND REPAIR SERVICE	25,000.00	452.11	7,425.52	0.00	17,574.48	29.70

Account Level						2025-26	February 2025-26	2025-26	Encumbered	Unexpended	2025-26
Fnd T Acct	Obj Prj Loc	Prg	Description	Budget	Monthly Activity	FYTD Activity	Amount	Balance - YTD Act	FYTD %		
72210	SUPPORT REGULAR INSTRUCTION										
141 E 72210 355 000 00000 000	TRAVEL	43,000.00	3,611.73	24,504.79	0.00	18,495.21	56.99				
141 E 72210 429 000 00000 010	SUPPLIES & MATERIALS	0.00	0.00	0.00	0.00	0.00	0.00				
141 E 72210 429 000 00000 011	SUPPLIES & MATERIALS	0.00	0.00	0.00	0.00	0.00	0.00				
141 E 72210 432 000 00000 000	LIBRARY BOOKS	100,000.00	0.00	2,999.09	0.00	97,000.91	3.00				
141 E 72210 432 000 00002 000	LIBRARY BOOKS-ASBURY	0.00	0.00	0.00	0.00	0.00	0.00				
141 E 72210 432 000 00003 000	LIBRARY BOOKS-MIDWAY	0.00	0.00	0.00	0.00	0.00	0.00				
141 E 72210 432 000 00004 000	LIBRARY BOOKS-BCES	0.00	0.00	0.00	0.00	0.00	0.00				
141 E 72210 432 000 00005 000	LIBRARY BOOKS-BCMS	0.00	0.00	0.00	0.00	0.00	0.00				
141 E 72210 432 000 00006 000	LIBRARY BOOKS-GVES	0.00	2,714.70	5,245.14	0.00	-5,245.14	0.00				
141 E 72210 432 000 00007 000	LIBRARY BOOKS-FBES	0.00	320.15	3,359.46	0.00	-3,359.46	0.00				
141 E 72210 432 000 00008 000	LIBRARY BOOKS-GES	0.00	3,042.26	7,854.69	0.00	-7,854.69	0.00				
141 E 72210 432 000 00009 000	LIBRARY BOOKS-JES	0.00	0.00	0.00	0.00	0.00	0.00				
141 E 72210 432 000 00010 000	LIBRARY BOOKS-JMS	0.00	0.00	0.00	0.00	0.00	0.00				
141 E 72210 432 000 00011 000	LIBRARY BOOKS-LES	0.00	509.16	5,110.59	0.00	-5,110.59	0.00				
141 E 72210 432 000 00012 000	LIBRARY BOOKS-SCES	0.00	1,679.54	2,179.82	0.00	-2,179.82	0.00				
141 E 72210 432 000 00013 000	LIBRARY BOOKS-SSES	0.00	0.00	0.00	0.00	0.00	0.00				
141 E 72210 432 000 00014 000	LIBRARY BOOKS-WVES	0.00	0.00	0.00	0.00	0.00	0.00				
141 E 72210 432 000 00015 000	LIBRARY BOOKS-DBHS	0.00	6,908.34	11,052.83	0.00	-11,052.83	0.00				
141 E 72210 432 000 00016 000	LIBRARY BOOKS-DCHS	0.00	3,015.85	11,011.61	0.00	-11,011.61	0.00				
141 E 72210 432 000 00025 000	LIBRARY BOOKS-RVES	0.00	0.00	9,190.05	0.00	-9,190.05	0.00				
141 E 72210 499 000 00000 000	OTHER SUPPLIES AND MATERIALS	10,000.00	0.00	100.14	0.00	9,899.86	1.00				
141 E 72210 499 934 00000 000	OTHER SUPPLIES AND MATERIALS	0.00	0.00	0.00	0.00	0.00	0.00				
141 E 72210 524 000 00000 000	IN SERVICE / STAFF DEVELOPMENT	190,000.00	81,304.84	246,184.86	0.00	-56,184.86	129.57				
141 E 72210 --- --- ----- ---		2,382,419.00	280,819.60	1,507,962.34	0.00	874,456.66	63.30				
=====											
72220	SUPPORT SPECIAL EDUCATION -										
141 E 72220 105 000 00000 000	SUPERVISOR/DIRECTOR	214,517.00	10,749.75	89,184.92	0.00	125,332.08	41.57				
141 E 72220 117 000 00000 000	CAREER LADDER PROGRAM	0.00	0.00	0.00	0.00	0.00	0.00				
141 E 72220 124 000 00000 000	PSYCOLOGICAL PERSONNEL	145,123.00	10,151.18	65,907.08	0.00	79,215.92	45.41				
141 E 72220 127 000 00000 000	CAREER LADDER EXTENDED CONTRAC	0.00	0.00	0.00	0.00	0.00	0.00				
141 E 72220 135 000 00000 000	ASSESSMENT PERSONNEL	314,055.00	28,521.35	175,209.77	0.00	138,845.23	55.79				
141 E 72220 161 000 00000 000	SECRETARY(S)	46,426.00	1,747.20	16,598.40	0.00	29,827.60	35.75				
141 E 72220 162 000 00000 000	CLERICAL PERSONNEL	0.00	0.00	0.00	0.00	0.00	0.00				
141 E 72220 171 000 00000 000	SPEECH PATHOLOGIST	351,089.00	44,882.85	264,090.43	0.00	86,998.57	75.22				

Fnd T Acct	Obj Prj Loc	Prg Description	2025-26 Budget	February 2025-26 Monthly Activity	2025-26 FYTD Activity	Encumbered Amount	Unexpended Balance - YTD Act	2025-26 FYTD %
72220		SUPPORT SPECIAL EDUCATION -						
141 E 72220	189 000 00000 000	OTHER SALARIES & WAGES	148,099.00	12,418.01	71,289.02	0.00	76,809.98	48.14
141 E 72220	201 000 00000 000	SOCIAL SECURITY	75,597.00	6,318.42	39,741.37	0.00	35,855.63	52.57
141 E 72220	204 000 00000 000	STATE RETIREMENT	108,091.00	8,148.78	51,541.10	0.00	56,549.90	47.68
141 E 72220	206 000 00000 000	LIFE INSURANCE	500.00	0.00	0.00	0.00	500.00	0.00
141 E 72220	207 000 00000 000	MEDICAL INSURANCE	112,249.00	24,163.30	135,918.80	0.00	-23,669.80	121.09
141 E 72220	212 000 00000 000	EMPLOYER MEDICARE	17,680.00	1,477.70	9,294.39	0.00	8,385.61	52.57
141 E 72220	299 000 00000 000	OTHER FRINGE BENEFITS	0.00	0.00	0.00	0.00	0.00	0.00
141 E 72220	336 000 00000 000	MAINTENANCE AND REPAIR SERVICE	500.00	0.00	0.00	0.00	500.00	0.00
141 E 72220	355 000 00000 000	TRAVEL	25,000.00	1,736.55	13,122.32	0.00	11,877.68	52.49
141 E 72220	399 000 00000 000	OTHER CONTRACTED SERVICES	40,000.00	328.40	12,332.90	0.00	27,667.10	30.83
141 E 72220	499 000 00000 000	OTHER SUPPLIES AND MATERIALS	10,000.00	0.00	11,091.18	0.00	-1,091.18	110.91
141 E 72220	524 000 00000 000	IN SERVICE / STAFF DEVELOPMENT	5,000.00	8,646.00	11,783.35	0.00	-6,783.35	235.67
141 E 72220	599 000 00000 000	OTHER CHARGES	5,000.00	0.00	1,295.00	0.00	3,705.00	25.90
141 E 72220	--- --- ----- ---		1,618,926.00	159,289.49	968,400.03	0.00	650,525.97	59.82
=====								
72230		SUPPORT VOCATIONAL EDUCATION -						
141 E 72230	105 000 00000 000	SUPERVISOR/DIRECTOR	87,974.00	7,470.58	59,264.66	0.00	28,709.34	67.37
141 E 72230	117 000 00000 000	CAREER LADDER PROGRAM	0.00	0.00	0.00	0.00	0.00	0.00
141 E 72230	127 000 00000 000	CAREER LADDER EXTENDED CONTRAC	0.00	0.00	0.00	0.00	0.00	0.00
141 E 72230	161 000 00000 000	SECRETARY(S)	0.00	0.00	0.00	0.00	0.00	0.00
141 E 72230	201 000 00000 000	SOCIAL SECURITY	5,454.00	446.14	3,575.48	0.00	1,878.52	65.56
141 E 72230	204 000 00000 000	STATE RETIREMENT	5,076.00	672.35	5,333.82	0.00	-257.82	105.08
141 E 72230	206 000 00000 000	LIFE INSURANCE	100.00	6.10	36.60	0.00	63.40	36.60
141 E 72230	207 000 00000 000	MEDICAL INSURANCE	26,647.00	1,893.60	10,996.80	0.00	15,650.20	41.27
141 E 72230	212 000 00000 000	EMPLOYER MEDICARE	1,276.00	104.34	836.20	0.00	439.80	65.53
141 E 72230	299 000 00000 000	OTHER FRINGE BENEFITS	0.00	0.00	0.00	0.00	0.00	0.00
141 E 72230	336 000 00000 000	MAINTENANCE AND REPAIR SERVICE	10,000.00	0.00	0.00	0.00	10,000.00	0.00
141 E 72230	355 000 00000 000	TRAVEL	35,000.00	18,988.27	34,313.83	0.00	686.17	98.04
141 E 72230	399 001 00000 000	OTHER CONTR. SERVS-STEM MIDDLE	60,000.00	0.00	0.00	0.00	60,000.00	0.00
141 E 72230	499 000 00000 000	OTHER SUPPLIES AND MATERIALS	4,500.00	0.00	571.60	0.00	3,928.40	12.70
141 E 72230	--- --- ----- ---		236,027.00	29,581.38	114,928.99	0.00	121,098.01	48.69
=====								

Fnd T Acct	Obj Prj Loc	Prg Description	2025-26 Budget	February 2025-26 Monthly Activity	2025-26 FYTD Activity	Encumbered Amount	Unexpended Balance - YTD Act	2025-26 FYTD %
72250		SUPPORT EDUCATION TECHNOLOGY						
141 E 72250	105 000	00000 000 TECHNOLOGY SUPERVISOR	313,324.00	22,939.05	198,405.28	0.00	114,918.72	63.32
141 E 72250	121 000	00000 000 DATA PROCESSING PERSONNEL	181,192.00	13,731.24	123,581.16	0.00	57,610.84	68.20
141 E 72250	138 000	00000 000 INSTRUCTIONAL COMPUTER PERSONN	77,803.00	6,419.42	38,516.52	0.00	39,286.48	49.51
141 E 72250	161 000	00000 000 SECRETARY	0.00	0.00	0.00	0.00	0.00	0.00
141 E 72250	189 000	00000 000 OTHER SALARIES & WAGES	417,456.00	30,919.36	276,601.81	0.00	140,854.19	66.26
141 E 72250	201 000	00000 000 SOCIAL SECURITY	61,366.00	4,371.69	38,237.86	0.00	23,128.14	62.31
141 E 72250	204 000	00000 000 STATE RETIREMENT	130,551.00	9,761.78	80,455.93	0.00	50,095.07	61.63
141 E 72250	206 000	00000 000 LIFE INSURANCE	500.00	47.90	287.40	0.00	212.60	57.48
141 E 72250	207 000	00000 000 MEDICAL INSURANCE	128,846.00	14,331.20	81,580.80	0.00	47,265.20	63.32
141 E 72250	212 000	00000 000 EMPLOYER MEDICARE	14,352.00	1,022.44	8,942.80	0.00	5,409.20	62.31
141 E 72250	299 000	00000 000 OTHER FRINGE BENEFITS	0.00	0.00	0.00	0.00	0.00	0.00
141 E 72250	350 000	00000 000 INTERNET CONNECTIVITY FEE	145,000.00	5,139.00	48,547.00	0.00	96,453.00	33.48
141 E 72250	355 000	00000 000 TRAVEL	7,000.00	0.00	5,809.76	0.00	1,190.24	83.00
141 E 72250	399 000	00000 000 OTHER CONTRACTED SERVICES	550,000.00	24,356.28	659,884.18	0.00	-109,884.18	119.98
141 E 72250	499 000	00000 000 OTHER SUPPLIES & MATERIALS	553,367.00	18,385.57	193,234.82	0.00	360,132.18	34.92
141 E 72250	524 440	00000 000 IN-SERVICE/STAFF DEVELOPMENT	0.00	0.00	0.00	0.00	0.00	0.00
141 E 72250	599 000	00000 000 OTHER CHARGES	0.00	0.00	0.00	0.00	0.00	0.00
141 E 72250	---	-----	2,580,757.00	151,424.93	1,754,085.32	0.00	826,671.68	67.97
			=====	=====	=====	=====	=====	=====
72310		BOARD OF EDUCATION SERVICES						
141 E 72310	191 000	00000 000 BOARD AND COMMITTEE MEMBERS FE	41,700.00	3,475.00	27,800.00	0.00	13,900.00	66.67
141 E 72310	201 000	00000 000 SOCIAL SECURITY	2,585.00	141.16	1,287.66	0.00	1,297.34	49.81
141 E 72310	204 000	00000 000 STATE RETIREMENT	5,500.00	458.34	3,666.72	0.00	1,833.28	66.67
141 E 72310	207 000	00000 000 MEDICAL INSURANCE	66,731.00	6,075.60	34,635.60	0.00	32,095.40	51.90
141 E 72310	212 000	00000 000 EMPLOYER MEDICARE	605.00	33.01	301.18	0.00	303.82	49.78
141 E 72310	305 000	00000 000 AUDIT SERVICES	60,000.00	0.00	83,175.00	0.00	-23,175.00	138.63
141 E 72310	320 000	00000 000 DUES AND MEMBERSHIPS	33,669.00	0.00	3,000.00	0.00	30,669.00	8.91
141 E 72310	331 000	00000 000 LEGAL SERVICES	54,000.00	4,500.00	36,000.00	0.00	18,000.00	66.67
141 E 72310	355 000	00000 000 TRAVEL	23,000.00	3,795.00	23,442.63	0.00	-442.63	101.92
141 E 72310	399 000	00000 000 OTHER CONTRACTED SERVICES	404,680.00	13,267.94	121,320.72	0.00	283,359.28	29.98
141 E 72310	502 000	00000 000 BUILDING & CONTENTS INSURANCE	131,000.00	0.00	579,998.00	0.00	-448,998.00	442.75
141 E 72310	506 000	00000 000 LIABILITY INSURANCE	139,600.00	0.00	84,126.00	0.00	55,474.00	60.26
141 E 72310	508 000	00000 000 PREMIUMS ON CORPORATE SURETY B	17,000.00	0.00	82,857.00	0.00	-65,857.00	487.39
141 E 72310	510 000	00000 000 TRUSTEE'S COMMISSION	680,000.00	101,875.82	426,186.70	0.00	253,813.30	62.67

Fnd T Acct	Obj Prj Loc	Prg Description	2025-26 Budget	February 2025-26 Monthly Activity	2025-26 FYTD Activity	Encumbered Amount	Unexpended Balance - YTD Act	2025-26 FYTD %
72310 BOARD OF EDUCATION SERVICES								
141 E 72310	513 000 00000 000	WORKER'S COMPENSATION INSURANC	300,000.00	0.00	255,013.29	0.00	44,986.71	85.00
141 E 72310	599 000 00000 000	OTHER CHARGES	0.00	1,583.50	32,898.03	0.00	-32,898.03	0.00
141 E 72310 --- --- ----- ---			1,960,070.00	135,205.37	1,795,708.53	0.00	164,361.47	91.61
72320 OFFICE OF THE DIRECTOR								
141 E 72320	101 000 00000 000	DIRECTOR OF SCHOOLS	165,000.00	13,750.00	110,000.00	0.00	55,000.00	66.67
141 E 72320	117 000 00000 000	CAREER LADDER PROGRAM	1,000.00	0.00	1,500.00	0.00	-500.00	150.00
141 E 72320	127 000 00000 000	CAREER LADDER EXTENDED CONTRAC	0.00	0.00	0.00	0.00	0.00	0.00
141 E 72320	161 000 00000 000	SECRETARY(S)	378,664.00	29,774.97	275,209.53	0.00	103,454.47	72.68
141 E 72320	188 000 00000 000	BONUS	10,000.00	0.00	10,000.00	0.00	0.00	100.00
141 E 72320	189 000 00000 000	OTHER SALARIES & WAGES	49,795.00	3,763.24	33,869.16	0.00	15,925.84	68.02
141 E 72320	201 000 00000 000	SOCIAL SECURITY	37,476.00	2,696.25	25,305.56	0.00	12,170.44	67.52
141 E 72320	204 000 00000 000	STATE RETIREMENT	67,411.00	5,217.08	47,778.16	0.00	19,632.84	70.88
141 E 72320	206 000 00000 000	LIFE INSURANCE	200.00	17.40	104.40	0.00	95.60	52.20
141 E 72320	207 000 00000 000	MEDICAL INSURANCE	80,029.00	15,095.40	91,147.20	0.00	-11,118.20	113.89
141 E 72320	212 000 00000 000	EMPLOYER MEDICARE	9,308.00	630.56	5,918.06	0.00	3,389.94	63.58
141 E 72320	299 000 00000 000	OTHER FRINGE BENEFITS	0.00	0.00	0.00	0.00	0.00	0.00
141 E 72320	307 000 00000 000	COMMUNICATION	75,000.00	5,491.96	42,583.86	0.00	32,416.14	56.78
141 E 72320	348 000 00000 000	POSTAL CHARGES	14,000.00	2,630.91	7,769.76	0.00	6,230.24	55.50
141 E 72320	355 000 00000 000	TRAVEL	10,000.00	1,794.98	8,009.36	0.00	1,990.64	80.09
141 E 72320	399 000 00000 000	OTHER CONTRACTED SERVICES	85,000.00	17,417.75	124,060.30	0.00	-39,060.30	145.95
141 E 72320	435 000 00000 000	OFFICE SUPPLIES	5,000.00	309.91	3,563.58	0.00	1,436.42	71.27
141 E 72320 --- --- ----- ---			987,883.00	98,590.41	786,818.93	0.00	201,064.07	79.65
72410 OFFICE OF THE PRINCIPAL								
141 E 72410	104 000 00000 000	PRINCIPALS	1,239,375.00	91,986.30	731,962.82	0.00	507,412.18	59.06
141 E 72410	117 000 00000 000	CAREER LADDER PROGRAM	25,000.00	0.00	500.00	0.00	24,500.00	2.00
141 E 72410	127 000 00000 000	CAREER LADDER EXTENDED CONTRAC	0.00	0.00	0.00	0.00	0.00	0.00
141 E 72410	139 000 00000 000	ASSISTANT PRINCIPALS	1,477,400.00	122,998.55	733,356.14	0.00	744,043.86	49.64
141 E 72410	161 000 00000 000	SECRETARY(S)	963,919.00	80,685.91	538,171.34	0.00	425,747.66	55.83

Fnd T Acct	Obj Prj Loc	Prg	Account Level Description	2025-26 Budget	February 2025-26 Monthly Activity	2025-26 FYTD Activity	Encumbered Amount	Unexpended Balance - YTD Act	2025-26 FYTD %
72410			OFFICE OF THE PRINCIPAL						
141 E 72410	162 000	00000 000	SECRETARIES & BOOKKEEPERS	0.00	0.00	0.00	0.00	0.00	0.00
141 E 72410	189 000	00000 000	OTHER SALARIES & WAGES	168,799.00	15,126.44	115,976.25	0.00	52,822.75	68.71
141 E 72410	201 000	00000 000	SOCIAL SECURITY	240,219.00	18,270.32	126,237.69	0.00	113,981.31	52.55
141 E 72410	204 000	00000 000	STATE RETIREMENT	307,606.00	25,519.33	174,593.32	0.00	133,012.68	56.76
141 E 72410	206 000	00000 000	LIFE INSURANCE	1,800.00	179.50	1,077.00	0.00	723.00	59.83
141 E 72410	207 000	00000 000	MEDICAL INSURANCE	610,031.00	58,404.80	338,785.60	0.00	271,245.40	55.54
141 E 72410	212 000	00000 000	EMPLOYER MEDICARE	56,180.00	4,272.91	29,523.22	0.00	26,656.78	52.55
141 E 72410	299 000	00000 000	OTHER FRINGE BENEFITS	0.00	0.00	0.00	0.00	0.00	0.00
141 E 72410	307 000	00000 000	COMMUNICATION	25,000.00	0.00	0.00	0.00	25,000.00	0.00
141 E 72410	307 000	00002 000	COMMUNICATION-ASBURY	0.00	0.00	0.00	0.00	0.00	0.00
141 E 72410	307 000	00003 000	COMMUNICATION-MIDWAY	0.00	0.00	0.00	0.00	0.00	0.00
141 E 72410	307 000	00004 000	COMMUNICATION-BCES	0.00	0.00	0.00	0.00	0.00	0.00
141 E 72410	307 000	00005 000	COMMUNICATION-BCMS	0.00	0.00	0.00	0.00	0.00	0.00
141 E 72410	307 000	00006 000	COMMUNICATION-GVES	0.00	0.00	0.00	0.00	0.00	0.00
141 E 72410	307 000	00007 000	COMMUNICATION-FBES	0.00	0.00	0.00	0.00	0.00	0.00
141 E 72410	307 000	00008 000	COMMUNICATION-GES	0.00	0.00	0.00	0.00	0.00	0.00
141 E 72410	307 000	00009 000	COMMUNICATION-JES	0.00	0.00	0.00	0.00	0.00	0.00
141 E 72410	307 000	00010 000	COMMUNICATION-JMS	0.00	0.00	0.00	0.00	0.00	0.00
141 E 72410	307 000	00011 000	COMMUNICATION-LES	0.00	0.00	0.00	0.00	0.00	0.00
141 E 72410	307 000	00012 000	COMMUNICATION-SCES	0.00	0.00	0.00	0.00	0.00	0.00
141 E 72410	307 000	00013 000	COMMUNICATION-SSES	0.00	0.00	0.00	0.00	0.00	0.00
141 E 72410	307 000	00014 000	COMMUNICATION-WVES	0.00	0.00	0.00	0.00	0.00	0.00
141 E 72410	307 000	00015 000	COMMUNICATION-DBHS	0.00	0.00	0.00	0.00	0.00	0.00
141 E 72410	307 000	00016 000	COMMUNICATION-DCHS	0.00	0.00	0.00	0.00	0.00	0.00
141 E 72410	307 000	00025 000	COMMUNICATION-RVES	0.00	0.00	0.00	0.00	0.00	0.00
141 E 72410	355 000	00000 000	TRAVEL	7,000.00	277.68	3,536.88	0.00	3,463.12	50.53
141 E 72410	499 000	00000 000	OTHER SUPPLIES AND MATERIALS	71,500.00	0.00	0.00	0.00	71,500.00	0.00
141 E 72410	499 000	00002 000	OTHER SUPP. & MATERIALS-ASBURY	0.00	0.00	0.00	0.00	0.00	0.00
141 E 72410	499 000	00003 000	OTHER SUPP. & MATERIALS-MIDWAY	0.00	0.00	0.00	0.00	0.00	0.00
141 E 72410	499 000	00004 000	OTHER SUPP. & MATERIALS-BCES	0.00	0.00	396.96	0.00	-396.96	0.00
141 E 72410	499 000	00005 000	OTHER SUPP. & MATERIALS-BCMS	0.00	0.00	0.00	0.00	0.00	0.00
141 E 72410	499 000	00006 000	OTHER SUPP. & MATERIALS-GVES	0.00	0.00	393.23	0.00	-393.23	0.00
141 E 72410	499 000	00007 000	OTHER SUPP. & MATERIALS-FBES	0.00	0.00	394.77	0.00	-394.77	0.00
141 E 72410	499 000	00008 000	OTHER SUPP. & MATERIALS-GES	0.00	0.00	357.01	0.00	-357.01	0.00
141 E 72410	499 000	00009 000	OTHER SUPP. & MATERIALS-JES	0.00	0.00	398.41	0.00	-398.41	0.00
141 E 72410	499 000	00010 000	OTHER SUPP. & MATERIALS-JMS	0.00	0.00	0.00	0.00	0.00	0.00
141 E 72410	499 000	00011 000	OTHER SUPP. & MATERIALS-LES	0.00	66.96	427.46	0.00	-427.46	0.00
141 E 72410	499 000	00012 000	OTHER SUPP. & MATERIALS-SCES	0.00	0.00	389.08	0.00	-389.08	0.00

Fnd T	Acct	Obj	Prj	Loc	Prg	Account Level Description	2025-26 Budget	February Monthly Activity	2025-26 FYTD Activity	Encumbered Amount	Unexpended Balance - YTD Act	2025-26 FYTD %
72410 OFFICE OF THE PRINCIPAL												
141	E	72410	499	000	00013	000 OTHER SUPP. & MATERIALS-SSES	0.00	0.00	398.56	0.00	-398.56	0.00
141	E	72410	499	000	00014	000 OTHER SUPP. & MATERIALS-WVES	0.00	0.00	412.72	0.00	-412.72	0.00
141	E	72410	499	000	00015	000 OTHER SUPP. & MATERIALS-DBHS	0.00	0.00	395.40	0.00	-395.40	0.00
141	E	72410	499	000	00016	000 OTHER SUPP. & MATERIALS-DCHS	0.00	0.00	395.40	0.00	-395.40	0.00
141	E	72410	499	000	00025	000 OTHER SUPP. & MATERIALS-RVES	0.00	0.00	303.87	0.00	-303.87	0.00
141	E	72410	599	000	00000	000 OTHER CHARGES	65,000.00	0.00	65,918.75	0.00	-918.75	101.41
141	E	72410	599	000	00000	001 OTHER CHARGES-PEPSI SPONSOR	33,443.00	0.00	0.00	0.00	33,443.00	0.00
141	E	72410	599	000	00000	002 OTHER CHARGES-PEPSI SCOREBOARD	10,000.00	0.00	0.00	0.00	10,000.00	0.00
141	E	72410	599	000	00000	003 OTHER CHARGES-PEPSI SCHOLARSHI	10,000.00	0.00	0.00	0.00	10,000.00	0.00
141 E 72410 --- --- ----- ---							5,312,272.00	417,788.70	2,864,301.88	0.00	2,447,970.12	53.92
							=====	=====	=====	=====	=====	=====
72510 FISCAL SERVICES												
141	E	72510	105	000	00000	000 SUPERVISOR/DIRECTOR	269,976.00	20,650.10	185,850.90	0.00	84,125.10	68.84
141	E	72510	119	000	00000	000 ACCOUNTING STAFF	189,820.00	14,416.00	129,744.00	0.00	60,076.00	68.35
141	E	72510	162	000	00000	000 ACCOUNTING CLERK	0.00	0.00	0.00	0.00	0.00	0.00
141	E	72510	201	000	00000	000 SOCIAL SECURITY	28,507.00	2,023.96	18,696.65	0.00	9,810.35	65.59
141	E	72510	204	000	00000	000 STATE RETIREMENT	60,647.00	4,625.22	41,626.98	0.00	19,020.02	68.64
141	E	72510	206	000	00000	000 LIFE INSURANCE	100.00	6.00	36.00	0.00	64.00	36.00
141	E	72510	207	000	00000	000 MEDICAL INSURANCE	54,443.00	8,397.20	48,837.60	0.00	5,605.40	89.70
141	E	72510	212	000	00000	000 EMPLOYER MEDICARE	6,667.00	473.34	4,372.66	0.00	2,294.34	65.59
141	E	72510	355	000	00000	000 TRAVEL	2,400.00	526.37	4,113.87	0.00	-1,713.87	171.41
141	E	72510	399	000	00000	000 OTHER CONTRACTED SERVICES	12,000.00	0.00	6,324.14	0.00	5,675.86	52.70
141	E	72510	499	000	00000	000 OTHER SUPPLIES AND MATERIALS	15,300.00	794.74	5,320.64	0.00	9,979.36	34.78
141 E 72510 --- --- ----- ---							639,860.00	51,912.93	444,923.44	0.00	194,936.56	69.53
							=====	=====	=====	=====	=====	=====
72520 HUMAN RESOURCES												
141	E	72520	105	000	00000	000 DIRECTOR	152,637.00	16,610.36	140,273.75	0.00	12,363.25	91.90
141	E	72520	188	000	00000	000 BONUS	0.00	0.00	0.00	0.00	0.00	0.00
141	E	72520	189	000	00000	000 OTHER SALARIES AND WAGES	103,729.00	8,257.56	74,318.04	0.00	29,410.96	71.65
141	E	72520	201	000	00000	000 SOCIAL SECURITY	15,895.00	1,383.64	12,372.22	0.00	3,522.78	77.84

Account Level						2025-26	February 2025-26	2025-26	Encumbered	Unexpended	2025-26
Fnd T Acct	Obj Prj Loc	Prg	Description	Budget	Monthly Activity	FYTD Activity	Amount	Balance - YTD Act	FYTD %		
72520 HUMAN RESOURCES											
141 E 72520 204 000 00000 000	STATE RETIREMENT					22,489.00	2,598.69	22,856.25	0.00	-367.25	101.63
141 E 72520 206 000 00000 000	LIFE INSURANCE					200.00	0.00	0.00	0.00	200.00	0.00
141 E 72520 207 000 00000 000	MEDICAL INSURANCE					60,347.00	5,425.20	35,253.60	0.00	25,093.40	58.42
141 E 72520 212 000 00000 000	MEDICARE					3,717.00	323.59	2,893.40	0.00	823.60	77.84
141 E 72520 355 000 00000 000	BOARD TRAVEL					2,000.00	1,208.75	1,208.75	0.00	791.25	60.44
141 E 72520 399 000 00000 000	OTHER CONTRACTED SERVICE					0.00	0.00	0.00	0.00	0.00	0.00
141 E 72520 499 000 00000 000	OTHER SUPPLIES AND MATERIALS					1,000.00	299.00	1,944.59	0.00	-944.59	194.46
141 E 72520 --- --- ----- ---						362,014.00	36,106.79	291,120.60	0.00	70,893.40	80.42
72610 OPERATION OF PLANT											
141 E 72610 166 000 00000 000	CUSTODIAL PERSONNEL					1,227,850.00	82,435.97	752,871.31	0.00	474,978.69	61.32
141 E 72610 189 000 00000 000	OTHER SALARIES & WAGES					330,220.00	28,343.79	247,693.71	0.00	82,526.29	75.01
141 E 72610 201 000 00000 000	SOCIAL SECURITY					96,600.00	6,414.57	59,819.61	0.00	36,780.39	61.93
141 E 72610 204 000 00000 000	STATE RETIREMENT					205,509.00	13,710.75	117,681.36	0.00	87,827.64	57.26
141 E 72610 206 000 00000 000	LIFE INSURANCE					700.00	69.50	417.00	0.00	283.00	59.57
141 E 72610 207 000 00000 000	MEDICAL INSURANCE					290,467.00	28,903.20	169,269.24	0.00	121,197.76	58.27
141 E 72610 212 000 00000 000	EMPLOYER MEDICARE					22,592.00	1,500.16	13,990.13	0.00	8,601.87	61.93
141 E 72610 328 000 00000 000	JANITORIAL SERVICES					1,776,796.00	0.00	4,564.04	0.00	1,772,231.96	0.26
141 E 72610 328 000 00002 000	JANITORIAL SERVICES-ASBURY					0.00	0.00	0.00	0.00	0.00	0.00
141 E 72610 328 000 00003 000	JANITORIAL SERVICES-MIDWAY					0.00	0.00	0.00	0.00	0.00	0.00
141 E 72610 328 000 00004 000	JANITORIAL SERVICES-BCES					0.00	17,680.24	141,441.92	0.00	-141,441.92	0.00
141 E 72610 328 000 00005 000	JANITORIAL SERVICES-BCMS					0.00	0.00	0.00	0.00	0.00	0.00
141 E 72610 328 000 00006 000	JANITORIAL SERVICES-GVES					0.00	11,512.72	92,101.76	0.00	-92,101.76	0.00
141 E 72610 328 000 00007 000	JANITORIAL SERVICES-FBES					0.00	6,578.69	52,629.52	0.00	-52,629.52	0.00
141 E 72610 328 000 00008 000	JANITORIAL SERVICES-GES					0.00	10,690.38	85,523.04	0.00	-85,523.04	0.00
141 E 72610 328 000 00009 000	JANITORIAL SERVICES-JES					0.00	17,675.35	141,402.80	0.00	-141,402.80	0.00
141 E 72610 328 000 00010 000	JANITORIAL SERVICES-JMS					0.00	0.00	0.00	0.00	0.00	0.00
141 E 72610 328 000 00011 000	JANITORIAL SERVICES-LES					0.00	9,868.03	78,944.24	0.00	-78,944.24	0.00
141 E 72610 328 000 00012 000	JANITORIAL SERVICES-SCES					0.00	7,812.21	62,497.68	0.00	-62,497.68	0.00
141 E 72610 328 000 00013 000	JANITORIAL SERVICES-SSES					0.00	8,223.37	65,786.96	0.00	-65,786.96	0.00
141 E 72610 328 000 00014 000	JANITORIAL SERVICES-WVES					0.00	7,812.21	62,497.68	0.00	-62,497.68	0.00
141 E 72610 328 000 00015 000	JANITORIAL SERVICES-DBHS					0.00	18,913.75	151,310.00	0.00	-151,310.00	0.00
141 E 72610 328 000 00016 000	JANITORIAL SERVICES-DCHS					0.00	18,913.75	151,310.00	0.00	-151,310.00	0.00
141 E 72610 328 000 00025 000	JANITORIAL SERVICES-RVES					0.00	11,512.72	92,101.76	0.00	-92,101.76	0.00

Fnd T	Acct	Obj	Prj	Loc	Prg	Account Level Description	2025-26 Budget	February Monthly Activity	2025-26 FYTD Activity	Encumbered Amount	Unexpended Balance - YTD Act	2025-26 FYTD %
72610						OPERATION OF PLANT						
141 E	72610	359	000	00000	000	DISPOSAL FEES	124,000.00	8,504.05	78,836.73	0.00	45,163.27	63.58
141 E	72610	359	000	00002	000	DISPOSAL FEES ASBURY	0.00	0.00	0.00	0.00	0.00	0.00
141 E	72610	359	000	00003	000	DISPOSAL FEES MIDWAY	0.00	0.00	0.00	0.00	0.00	0.00
141 E	72610	359	000	00004	000	DISPOSAL FEES BCES	0.00	0.00	0.00	0.00	0.00	0.00
141 E	72610	359	000	00005	000	DISPOSAL FEES OLD BCMS	0.00	0.00	0.00	0.00	0.00	0.00
141 E	72610	359	000	00006	000	DISPOSAL FEES GVES	0.00	603.26	7,021.15	0.00	-7,021.15	0.00
141 E	72610	359	000	00007	000	DISPOSAL FEES FBES	0.00	150.00	1,350.00	0.00	-1,350.00	0.00
141 E	72610	359	000	00008	000	DISPOSAL FEES GES	0.00	0.00	319.00	0.00	-319.00	0.00
141 E	72610	359	000	00009	000	DISPOSAL FEES JES	0.00	750.00	6,065.00	0.00	-6,065.00	0.00
141 E	72610	359	000	00010	000	DISPOSAL FEES JMS	0.00	0.00	220.43	0.00	-220.43	0.00
141 E	72610	359	000	00011	000	DISPOSAL FEES LES	0.00	0.00	3,510.94	0.00	-3,510.94	0.00
141 E	72610	359	000	00012	000	DISPOSAL FEES SCES	0.00	0.00	0.00	0.00	0.00	0.00
141 E	72610	359	000	00013	000	DISPOSAL FEES SSES	0.00	0.00	0.00	0.00	0.00	0.00
141 E	72610	359	000	00014	000	DISPOSAL FEES WVES	0.00	0.00	0.00	0.00	0.00	0.00
141 E	72610	359	000	00015	000	DISPOSAL FEES DBHS	0.00	2,589.23	16,250.78	0.00	-16,250.78	0.00
141 E	72610	359	000	00016	000	DISPOSAL FEES DCHS	0.00	824.48	15,042.84	0.00	-15,042.84	0.00
141 E	72610	359	000	00025	000	DISPOSAL FEES RVES	0.00	0.00	0.00	0.00	0.00	0.00
141 E	72610	399	000	00000	000	OTHER CONTRACTED SERVICES	149,000.00	2,708.86	37,628.90	0.00	111,371.10	25.25
141 E	72610	399	000	00002	000	OTHER CONTRACTED SERV. ASBURY	0.00	0.00	1,713.97	0.00	-1,713.97	0.00
141 E	72610	399	000	00003	000	OTHER CONTRACTED SERV MIDWAY	0.00	100.00	1,205.00	0.00	-1,205.00	0.00
141 E	72610	399	000	00004	000	OTHER CONTRACTED SERVICE BCES	0.00	0.00	4,707.60	0.00	-4,707.60	0.00
141 E	72610	399	000	00005	000	OTHER CONTRACTED SERVICE BCM	0.00	0.00	0.00	0.00	0.00	0.00
141 E	72610	399	000	00006	000	OTHER CONTRACTED SERVICE GVES	0.00	737.01	5,344.05	0.00	-5,344.05	0.00
141 E	72610	399	000	00007	000	OTHER CONTRACTED SERVICE FBES	0.00	0.00	2,855.00	0.00	-2,855.00	0.00
141 E	72610	399	000	00008	000	OTHER CONTRACTED SERVICE GES	0.00	0.00	2,236.99	0.00	-2,236.99	0.00
141 E	72610	399	000	00009	000	OTHER CONTRACTED SERVICE JES	0.00	0.00	2,644.95	0.00	-2,644.95	0.00
141 E	72610	399	000	00010	000	OTHER CONTRACTED SERVICE JMS	0.00	0.00	120.00	0.00	-120.00	0.00
141 E	72610	399	000	00011	000	OTHER CONTRACTED SERVICE LES	0.00	532.49	6,341.12	0.00	-6,341.12	0.00
141 E	72610	399	000	00012	000	OTHER CONTRACTED SERVICE SCES	0.00	0.00	3,938.86	0.00	-3,938.86	0.00
141 E	72610	399	000	00013	000	OTHER CONTRACTED SERVICE SSES	0.00	0.00	3,830.00	0.00	-3,830.00	0.00
141 E	72610	399	000	00014	000	OTHER CONTRACTED SERVICE WVES	0.00	0.00	6,035.98	0.00	-6,035.98	0.00
141 E	72610	399	000	00015	000	OTHER CONTRACTED SERVICE DBHS	0.00	0.00	5,129.67	0.00	-5,129.67	0.00
141 E	72610	399	000	00016	000	OTHER CONTRACTED SERVICE DCHS	0.00	1,823.73	17,594.28	0.00	-17,594.28	0.00
141 E	72610	399	000	00025	000	OTHER CONTRACTED SERVICE RVES	0.00	60.00	4,981.48	0.00	-4,981.48	0.00
141 E	72610	410	000	00000	000	CUSTODIAL SUPPLIES	136,500.00	180.14	12,873.39	0.00	123,626.61	9.43
141 E	72610	410	000	00002	000	CUSTODIAL SUPPLIES-ASBURY	0.00	0.00	1,421.68	0.00	-1,421.68	0.00
141 E	72610	410	000	00003	000	CUSTODIAL SUPPLIES-MIDWAY	0.00	0.00	976.34	0.00	-976.34	0.00
141 E	72610	410	000	00004	000	CUSTODIAL SUPPLIES-BCES	0.00	2,014.03	13,517.16	0.00	-13,517.16	0.00

Fnd T	Acct	Obj	Prj	Loc	Prg	Account Level Description	2025-26 Budget	February Monthly Activity	2025-26 FYTD Activity	Encumbered Amount	Unexpended Balance - YTD Act	2025-26 FYTD %
72610						OPERATION OF PLANT						
141 E	72610	434	000	00009	000	NATURAL GAS-JES	0.00	7,912.26	20,632.07	0.00	-20,632.07	0.00
141 E	72610	434	000	00010	000	NATURAL GAS-JMS	0.00	741.72	2,268.51	0.00	-2,268.51	0.00
141 E	72610	434	000	00011	000	NATURAL GAS-LES	0.00	7,590.43	12,261.94	0.00	-12,261.94	0.00
141 E	72610	434	000	00012	000	NATURAL GAS-SCES	0.00	0.00	0.00	0.00	0.00	0.00
141 E	72610	434	000	00013	000	NATURAL GAS-SSES	0.00	4,147.23	6,256.85	0.00	-6,256.85	0.00
141 E	72610	434	000	00014	000	NATURAL GAS-WVES	0.00	0.00	0.00	0.00	0.00	0.00
141 E	72610	434	000	00015	000	NATURAL GAS-DBHS	0.00	1,865.25	5,930.09	0.00	-5,930.09	0.00
141 E	72610	434	000	00016	000	NATURAL GAS-DCHS	0.00	8,740.63	31,323.63	0.00	-31,323.63	0.00
141 E	72610	434	000	00025	000	NATURAL GAS-RVES	0.00	0.00	0.00	0.00	0.00	0.00
141 E	72610	454	000	00000	000	WATER AND SEWER	266,832.00	231.49	10,585.95	0.00	256,246.05	3.97
141 E	72610	454	000	00002	000	WATER & SEWER-ASBURY	0.00	916.40	3,737.56	0.00	-3,737.56	0.00
141 E	72610	454	000	00003	000	WATER & SEWER-MIDWAY	0.00	65.47	219.95	0.00	-219.95	0.00
141 E	72610	454	000	00004	000	WATER & SEWER-BCES	0.00	4,913.27	28,540.27	0.00	-28,540.27	0.00
141 E	72610	454	000	00005	000	WATER & SEWER-BCMS	0.00	0.00	0.00	0.00	0.00	0.00
141 E	72610	454	000	00006	000	WATER & SEWER-GVES	0.00	1,928.69	11,156.84	0.00	-11,156.84	0.00
141 E	72610	454	000	00007	000	WATER & SEWER-FBES	0.00	255.17	2,520.64	0.00	-2,520.64	0.00
141 E	72610	454	000	00008	000	WATER & SEWER-GES	0.00	1,156.38	9,539.96	0.00	-9,539.96	0.00
141 E	72610	454	000	00009	000	WATER & SEWER-JES	0.00	957.21	8,412.83	0.00	-8,412.83	0.00
141 E	72610	454	000	00010	000	WATER & SEWER-JMS	0.00	247.69	1,254.88	0.00	-1,254.88	0.00
141 E	72610	454	000	00011	000	WATER & SEWER-LES	0.00	476.77	21,872.98	0.00	-21,872.98	0.00
141 E	72610	454	000	00012	000	WATER & SEWER-SCES	0.00	356.82	2,914.70	0.00	-2,914.70	0.00
141 E	72610	454	000	00013	000	WATER & SEWER-SSES	0.00	775.69	6,383.18	0.00	-6,383.18	0.00
141 E	72610	454	000	00014	000	WATER & SEWER-WVES	0.00	550.85	6,409.40	0.00	-6,409.40	0.00
141 E	72610	454	000	00015	000	WATER & SEWER-DBHS	0.00	3,569.84	28,131.16	0.00	-28,131.16	0.00
141 E	72610	454	000	00016	000	WATER & SEWER-DCHS	0.00	0.00	19,487.97	0.00	-19,487.97	0.00
141 E	72610	454	000	00025	000	WATER & SEWER-RVES	0.00	1,852.00	11,648.44	0.00	-11,648.44	0.00
141 E	72610	499	000	00000	000	OTHER SUPPLIES AND MATERIALS	96,289.00	7,350.00	86,816.14	0.00	9,472.86	90.16
141 E	72610	499	000	00000	020	TAEP -AGRICULTURAL GRANT	0.00	0.00	0.00	0.00	0.00	0.00
141 E	72610	501	000	00000	000	BOILER INSURANCE	21,000.00	0.00	14,881.00	0.00	6,119.00	70.86
141 E	72610	599	000	00000	000	OTHER CHARGES	39,900.00	1,072.03	24,381.32	0.00	15,518.68	61.11
141 E	72610	599	000	00002	000	OTHER CHARGES ASBURY	0.00	404.64	2,892.33	0.00	-2,892.33	0.00
141 E	72610	599	000	00003	000	OTHER CHARGES MIDWAY	0.00	145.00	918.04	0.00	-918.04	0.00
141 E	72610	599	000	00004	000	OTHER CHARGES BCES	0.00	290.92	1,959.19	0.00	-1,959.19	0.00
141 E	72610	599	000	00005	000	OTHER CHARGES BCMS	0.00	0.00	0.00	0.00	0.00	0.00
141 E	72610	599	000	00006	000	OTHER CHARGES GVES	0.00	0.00	0.00	0.00	0.00	0.00
141 E	72610	599	000	00007	000	OTHER CHARGES FBES	0.00	0.00	0.00	0.00	0.00	0.00
141 E	72610	599	000	00008	000	OTHER CHARGES GES	0.00	0.00	0.00	0.00	0.00	0.00
141 E	72610	599	000	00009	000	OTHER CHARGES JES	0.00	513.68	4,160.03	0.00	-4,160.03	0.00

Account Level						2025-26	February 2025-26	2025-26	Encumbered	Unexpended	2025-26
Fnd T Acct	Obj Prj Loc	Prg	Description	Budget	Monthly Activity	FYTD Activity	Amount	Balance - YTD Act	FYTD %		
72610 OPERATION OF PLANT											
141 E 72610 599 000 00010 000	OTHER CHARGES JMS					0.00	0.00	0.00	0.00	0.00	0.00
141 E 72610 599 000 00011 000	OTHER CHARGES LES					0.00	0.00	0.00	0.00	0.00	0.00
141 E 72610 599 000 00012 000	OTHER CHARGES SCES					0.00	0.00	0.00	0.00	0.00	0.00
141 E 72610 599 000 00013 000	OTHER CHARGES SSES					0.00	0.00	437.88	0.00	-437.88	0.00
141 E 72610 599 000 00014 000	OTHER CHARGES WVES					0.00	130.60	838.37	0.00	-838.37	0.00
141 E 72610 599 000 00015 000	OTHER CHARGES DBHS					0.00	804.68	6,800.88	0.00	-6,800.88	0.00
141 E 72610 599 000 00016 000	OTHER CHARGES DCHS					0.00	0.00	0.00	0.00	0.00	0.00
141 E 72610 599 000 00025 000	OTHER CHARGES RVES					0.00	0.00	55.00	0.00	-55.00	0.00
141 E 72610 --- --- ----- ---						6,843,360.00	618,608.95	4,677,368.54	0.00	2,165,991.46	68.35
72620 MAINTENANCE OF PLANT											
141 E 72620 105 000 00000 000	SUPERVISOR/DIRECTOR					294,769.00	22,412.80	201,715.20	0.00	93,053.80	68.43
141 E 72620 167 000 00000 000	MAINTENANCE PERSONNEL					1,008,735.00	72,855.69	649,473.29	0.00	359,261.71	64.38
141 E 72620 201 000 00000 000	SOCIAL SECURITY					80,817.00	5,612.69	50,982.45	0.00	29,834.55	63.08
141 E 72620 204 000 00000 000	STATE RETIREMENT					171,932.00	12,070.10	105,285.17	0.00	66,646.83	61.24
141 E 72620 206 000 00000 000	LIFE INSURANCE					300.00	28.10	168.60	0.00	131.40	56.20
141 E 72620 207 000 00000 000	MEDICAL INSURANCE					161,677.00	24,909.20	142,236.00	0.00	19,441.00	87.98
141 E 72620 212 000 00000 000	EMPLOYER MEDICARE					18,901.00	1,312.68	11,923.26	0.00	6,977.74	63.08
141 E 72620 304 000 00000 000	ARCHITECTS					0.00	0.00	0.00	0.00	0.00	0.00
141 E 72620 307 000 00000 000	COMMUNICATION					2,700.00	107.39	889.88	0.00	1,810.12	32.96
141 E 72620 335 000 00000 000	MAINTENANCE & REPAIR - BUILDIN					226,191.00	636.00	636.00	0.00	225,555.00	0.28
141 E 72620 335 000 00002 000	MAINT. & REPAIR BUILD. ASBURY					0.00	0.00	0.00	0.00	0.00	0.00
141 E 72620 335 000 00003 000	MAINT. & REPAIR BUILD. MIDWAY					0.00	0.00	0.00	0.00	0.00	0.00
141 E 72620 335 000 00004 000	MAINT. & REPAIR BUILD. BCES					0.00	0.00	0.00	0.00	0.00	0.00
141 E 72620 335 000 00005 000	MAINT. & REPAIR BUILD. BCMS					0.00	0.00	0.00	0.00	0.00	0.00
141 E 72620 335 000 00006 000	MAINT. & REPAIR BUILD. GVES					0.00	0.00	4,263.00	0.00	-4,263.00	0.00
141 E 72620 335 000 00007 000	MAINT. & REPAIR BUILD. FBES					0.00	0.00	0.00	0.00	0.00	0.00
141 E 72620 335 000 00008 000	MAINT. & REPAIR BUILD. GES					0.00	0.00	3,859.50	0.00	-3,859.50	0.00
141 E 72620 335 000 00009 000	MAINT. & REPAIR BUILD. JES					0.00	0.00	0.00	0.00	0.00	0.00
141 E 72620 335 000 00010 000	MAINT. & REPAIR BUILD. JMS					0.00	0.00	0.00	0.00	0.00	0.00
141 E 72620 335 000 00011 000	MAINT. & REPAIR BUILD. LES					0.00	0.00	13,125.14	0.00	-13,125.14	0.00
141 E 72620 335 000 00012 000	MAINT. & REPAIR BUILD. SCES					0.00	0.00	4,116.00	0.00	-4,116.00	0.00
141 E 72620 335 000 00013 000	MAINT. & REPAIR BUILD. SSES					0.00	9,999.00	14,527.00	0.00	-14,527.00	0.00
141 E 72620 335 000 00014 000	MAINT. & REPAIR BUILD. WVES					0.00	0.00	4,116.00	0.00	-4,116.00	0.00

Fnd T	Acct	Obj	Prj	Loc	Prg	Account Level Description	2025-26 Budget	February 2025-26 Monthly Activity	2025-26 FYTD Activity	Encumbered Amount	Unexpended Balance - YTD Act	2025-26 FYTD %
72620						MAINTENANCE OF PLANT						
141 E	72620	499	000	00025	000	OTHER SUPPLIES & MAT. RVES	0.00	0.00	0.00	0.00	0.00	0.00
141 E	72620	599	000	00000	000	OTHER CHARGES	28,418.00	3,725.69	35,184.57	0.00	-6,766.57	123.81
141 E	72620	701	000	00000	000	ADMINISTRATION EQUIPMENT	0.00	0.00	0.00	0.00	0.00	0.00
141 E	72620	701	000	00000	004	PUBLIC SCHOOL SECURITY GRANT	0.00	0.00	0.00	0.00	0.00	0.00
141 E	72620	790	000	00000	004	OTHER EQUIPMENT	0.00	0.00	19,620.00	0.00	-19,620.00	0.00
141 E	72620	---	---	-----	---		2,885,782.00	323,223.53	1,941,329.95	0.00	944,452.05	67.27
							=====	=====	=====	=====	=====	=====
72710						STUDENT TRANSPORTATION						
141 E	72710	105	000	00000	000	SUPERVISOR/DIRECTOR	147,479.00	11,201.54	100,813.86	0.00	46,665.14	68.36
141 E	72710	142	000	00000	000	MECHANIC(S)	254,051.00	19,625.22	173,601.75	0.00	80,449.25	68.33
141 E	72710	146	000	00000	000	BUS DRIVERS	1,579,575.00	151,560.96	928,798.08	0.00	650,776.92	58.80
141 E	72710	146	000	00000	002	CTE ISM GRANT	0.00	0.00	0.00	0.00	0.00	0.00
141 E	72710	189	000	00000	000	OTHER PERSONEL	49,795.00	3,761.62	33,854.58	0.00	15,940.42	67.99
141 E	72710	201	000	00000	000	SOCIAL SECURITY	125,916.00	10,751.60	72,619.69	0.00	53,296.31	57.67
141 E	72710	201	000	00000	002	SS-ISM GRANT	0.00	0.00	0.00	0.00	0.00	0.00
141 E	72710	204	000	00000	000	STATE RETIREMENT	261,308.00	22,983.69	154,465.87	0.00	106,842.13	59.11
141 E	72710	204	000	00000	002	STATE RETIREMENT ISM	0.00	0.00	0.00	0.00	0.00	0.00
141 E	72710	206	000	00000	000	LIFE INSURANCE	1,550.00	151.70	910.20	0.00	639.80	58.72
141 E	72710	207	000	00000	000	MEDICAL INSURANCE	548,362.00	51,879.80	300,885.20	0.00	247,476.80	54.87
141 E	72710	212	000	00000	000	EMPLOYER MEDICARE	28,726.00	2,553.91	17,316.63	0.00	11,409.37	60.28
141 E	72710	212	000	00000	002	MEDICARE -ISM	0.00	0.00	0.00	0.00	0.00	0.00
141 E	72710	307	000	00000	000	COMMUNICATION	750.00	19.14	454.77	0.00	295.23	60.64
141 E	72710	330	000	00000	000	OPERATING LEASE PAYMENTS	73,400.00	0.00	36,845.90	0.00	36,554.10	50.20
141 E	72710	338	000	00000	000	MAINTENANCE & REPAIR	0.00	0.00	0.00	0.00	0.00	0.00
141 E	72710	399	000	00000	000	OTHER CONTRACTED SERVICES	5,000.00	224.83	4,302.09	0.00	697.91	86.04
141 E	72710	412	000	00000	000	DIESEL FUEL	283,000.00	18,753.12	126,476.91	0.00	156,523.09	44.69
141 E	72710	412	000	00000	002	CTE ISM GRANT	0.00	0.00	0.00	0.00	0.00	0.00
141 E	72710	424	000	00000	000	GARAGE SUPPLIES	30,000.00	362.84	5,674.00	0.00	24,326.00	18.91
141 E	72710	425	000	00000	000	GASOLINE	171,867.00	9,979.40	100,858.68	0.00	71,008.32	58.68
141 E	72710	425	000	00000	002	CTE ISM GRANT	0.00	0.00	0.00	0.00	0.00	0.00
141 E	72710	442	000	00000	000	PROPANE GAS-VEHICLES	80,000.00	8,754.83	57,551.85	0.00	22,448.15	71.94
141 E	72710	450	000	00000	000	TIRES AND TUBES	60,000.00	4,382.55	16,002.33	0.00	43,997.67	26.67
141 E	72710	453	000	00000	000	VEHICLE PARTS	160,000.00	22,659.58	104,191.98	0.00	55,808.02	65.12
141 E	72710	499	000	00000	000	OTHER SUPPLIES AND MATERIALS	5,250.00	0.00	6,700.39	0.00	-1,450.39	127.63

Fnd T Acct	Obj Prj Loc	Prg	Account Level Description	2025-26 Budget	February 2025-26 Monthly Activity	2025-26 FYTD Activity	Encumbered Amount	Unexpended Balance - YTD Act	2025-26 FYTD %
73100			FOOD SERVICE						
141 E 73100 299 000 00000 000			OTHER FRINGE BENEFITS	0.00	0.00	0.00	0.00	0.00	0.00
141 E 73100 --- --- ----- ---				0.00	0.00	0.00	0.00	0.00	0.00
=====									
73300			COMMUNITY SERVICES						
141 E 73300 105 000 00000 000			SUPERVISOR/DIRECTOR	66,792.00	6,557.90	55,626.10	0.00	11,165.90	83.28
141 E 73300 116 000 00000 000			TEACHERS	0.00	2,244.00	15,411.00	0.00	-15,411.00	0.00
141 E 73300 161 000 00000 000			SECRETARY(S)	0.00	0.00	0.00	0.00	0.00	0.00
141 E 73300 162 000 00000 000			SECRETARY	45,448.00	3,540.57	31,536.94	0.00	13,911.06	69.39
141 E 73300 163 000 00000 000			EDUCATIONAL ASSISTANTS	0.00	50.00	630.00	0.00	-630.00	0.00
141 E 73300 169 000 00000 000			PART-TIME PERSONNEL	0.00	0.00	0.00	0.00	0.00	0.00
141 E 73300 189 000 00000 000			OTHER SALARIES & WAGES	446,076.00	24,589.88	286,945.20	0.00	159,130.80	64.33
141 E 73300 189 000 00100 000			BCES CHILDCARE ANNEX SALARIES	0.00	0.00	0.00	0.00	0.00	0.00
141 E 73300 201 000 00000 000			SOCIAL SECURITY	34,616.00	2,191.68	23,564.50	0.00	11,051.50	68.07
141 E 73300 201 000 00100 000				0.00	0.00	0.00	0.00	0.00	0.00
141 E 73300 204 000 00000 000			STATE RETIREMENT	73,642.00	2,632.95	24,989.18	0.00	48,652.82	33.93
141 E 73300 207 000 00000 000			MEDICAL INSURANCE	27,852.00	2,622.00	15,228.00	0.00	12,624.00	54.67
141 E 73300 212 000 00000 000			EMPLOYER MEDICARE	0.00	512.57	5,511.06	0.00	-5,511.06	0.00
141 E 73300 212 000 00100 000				0.00	0.00	0.00	0.00	0.00	0.00
141 E 73300 355 000 00000 000			TRAVEL	2,000.00	0.00	627.20	0.00	1,372.80	31.36
141 E 73300 422 000 00000 000			FOOD SUPPLIES	30,000.00	0.00	0.00	0.00	30,000.00	0.00
141 E 73300 429 000 00000 100			OTHER SUPPLIES & MAT_LOT GRANT	0.00	0.00	736.04	0.00	-736.04	0.00
141 E 73300 499 000 00000 000			OTHER SUPPLIES AND MATERIALS	20,000.00	42.00	11,465.68	0.00	8,534.32	57.33
141 E 73300 524 000 00000 100			IN-SERVICE/STAFF DEV. - LOT GR	0.00	0.00	650.46	0.00	-650.46	0.00
141 E 73300 599 000 00000 000			OTHER CHARGES	13,000.00	50.01	451.96	0.00	12,548.04	3.48
141 E 73300 599 000 00000 100			OTHER CHARGES_LOT GRANT	0.00	0.00	0.00	0.00	0.00	0.00
141 E 73300 --- --- ----- ---				759,426.00	45,033.56	473,373.32	0.00	286,052.68	62.33
=====									

Account Level		2025-26	February 2025-26	2025-26	Encumbered	Unexpended	2025-26
Fnd T Acct	Obj Prj Loc Prg Description	Budget	Monthly Activity	FYTD Activity	Amount	Balance - YTD Act	FYTD %
76100	REGULAR CAPITAL OUTLAY						
141 E 76100 790 000 00000 000	OTHER EQUIPMENT	0.00	0.00	0.00	0.00	0.00	0.00
141 E 76100 799 000 00000 000	OTHER CAPITAL OUTLAY	0.00	0.00	0.00	0.00	0.00	0.00
141 E 76100 --- --- --- ---		100,000.00	0.00	52,698.51	0.00	47,301.49	52.70
=====							
99100	TRANSFERS						
141 E 99100 316 000 00000 000	CONTRIBUTIONS TO DS	0.00	0.00	0.00	0.00	0.00	0.00
141 E 99100 590 000 00000 000	TRANSFERS TO OTHER FUNDS	350,000.00	28,241.00	254,169.00	0.00	95,831.00	72.62
141 E 99100 --- --- --- ---		350,000.00	28,241.00	254,169.00	0.00	95,831.00	72.62
=====							
141 - --- --- --- --- ---		98,925,983.00	8,483,285.28	57,423,982.34	0.00	41,502,000.66	58.05

Number of Accounts: 818

***** End of report *****

Acct	Obj	Prj	Loc	Prg	Description	Amount
A Asset						
11140	000	000	00000	000	CASH WITH TRUSTEE D.	151,830.61CR
11140	000	000	99141	141	CASH WITH TRUSTEE	29,434,418.33
11140	000	000	99142	142		0.00
11140	000	001	99141	141		0.00
11140	000	003	99141	141		0.00
11140	000	100	99141	141		0.00
11140	000	995	99141	141		1,034.77CR
11300	000	000	00000	000	INVESTMENTS	0.00
11410	000	000	00000	000	ACCOUNTS RECEIVABLE	0.00
11420	000	000	00000	000	Allowance for Doubtful Accts.	0.00
11430	000	000	00000	000	DUE FROM OTHER GOVERNMENTS	3,727,341.36
11430	000	160	00000	000	DUE FROM OTHER GOVERNMENTS	0.00
11440	000	000	00000	000	DUE FROM OTHER FUNDS	0.00
11500	000	000	00000	000	PROPERTY TAX RECEIVABLE	14,737,383.00
11510	000	000	00000	000	ALLOWANCE FOR UNCOLL. PROPERTY	277,394.00CR
11600	000	000	00000	000	PRE-PAID ITEMS	0.00
11820	000	000	10000	602	CASH SHORTAGE	0.00
11890	000	000	00000	000	OTHER CURRENT ASSETS	0.00
-----						47,468,883.31
						=====

L Liability						
21100	000	000	00000	000	ACCOUNTS PAYABLE	668,267.58CR
21100	000	001	00000	000		0.00
21100	000	100	00000	000		0.00
21100	000	995	00000	000		0.00
21200	000	000	00000	000	ACCRUED PAYROLL	0.00
21300	000	000	00000	000	PAYROLL ADJUSTMENTS	0.00
21310	000	000	00000	000	INCOME TAX WITHHELD AND UNPAID	0.00
21310	000	003	00000	000		0.00
21310	000	995	00000	000		0.00
21320	000	000	00000	000	SOCIAL SECURITY TAX	8.76
21320	000	003	00000	000		0.00
21320	000	995	00000	000		0.00
21325	000	000	00000	000	EMPLOYEE MEDICARE DEDUCTION	32.50
21325	000	003	00000	000		0.00
21325	000	995	00000	000		30.46CR
21330	000	000	00000	000	RETIREMENT CONTRIBUTIONS	901,105.13CR
21330	000	003	00000	000		0.00
21330	000	995	00000	000		0.00
21331	000	000	00000	000	HYBRID EMPLOYER CONTRIBUTION	0.00
21339	000	000	00000	000	STATE DENTAL PLAN	79,611.05CR
21340	000	000	00000	000	MEDICAL INSURANCE CONTRIBUTION	1,114,106.29CR
21341	000	000	00000	000	COLONIAL LIFE INS PAYABLE	0.00
21342	000	000	00000	000	HARTFORD ROTH	0.00
21342	201	000	00000	000	SOCIAL SECURITY	0.00
21342	204	000	00000	000	STATE RETIREMENT	0.00
21342	207	000	00000	000	MEDICAL INSURANCE	0.00
21342	212	000	00000	000	MEDICARE	0.00
21343	000	000	00000	000	AMERICAN FAMILY LIFE PAYABLE	1,218.57
21344	000	000	00000	000	HORACE MANN LIFE INS PAYABLE	0.00
21345	000	000	00000	000	CITIZENS SECURITY DENTAL	0.00

Acct	Obj	Prj	Loc	Prg	Description	Amount
L Liability						
21346	000	000	00000	000	WASHINGTON NATIONAL INS CO	0.00
21347	000	000	00000	000	LIBERTY NATIONAL INS PAYABLE	0.00
21348	000	000	00000	000	MEDICAL INSURANCE PAYABLE	8,832.60CR
21349	000	000	00000	000	UNITED WAY	0.00
21350	000	000	00000	000	NTA LIFE BUSINESS SERVICES	0.00
21351	000	000	00000	000	HORACE MANN ANNUITY PAYABLE	0.00
21352	000	000	00000	000	TRANSAMERICA	0.00
21353	000	000	00000	000	DAVIS VISION	31,139.26CR
21354	000	000	00000	000	ONE AMERICA	80.88
21355	000	000	00000	000	EDUCATIONAL PLANNING GROUP	0.00
21356	000	000	00000	000	TRUSTMARK	13.39CR
21357	000	000	00000	000	MODERN WOODMEN INS PAYABLE	0.00
21358	000	000	00000	000	HYBRID-TAXED CONTRIBUTION	24,183.19
21359	000	000	00000	000	HYBRID PRETAXED CONTRIBUTION	80,688.31
21360	000	000	00000	000	GARNISHMENTS AND LEVIES	20,750.01
21361	000	000	00000	000	CENTRAL STATES HEALTH & LIFE C	0.00
21362	000	000	00000	000	USABLE LIFE	0.00
21362	201	000	00000	000	SOCIAL SECURITY	0.00
21362	204	000	00000	000	STATE RETIREMENT	0.00
21362	207	000	00000	000	MEDICAL INSURANCE	0.00
21362	212	000	00000	000	MEDICARE	0.00
21363	000	000	00000	000	MISCELLANEOUS DEDUCTIONS	0.00
21364	000	000	00000	000	LEGAL SHIELD	0.00
21365	000	000	00000	000	WAGWORKS	365.00
21365	000	440	00000	000	WAGWORKS	0.00
21366	000	000	00000	000	VALU TEACHERS	0.00
21367	000	000	00000	000	LIFE INSURANCE OF ALABAMA	0.00
21370	000	000	00000	000	AIG RETIREMENT (VALIC)	0.00
21380	000	000	00000	000	CREDIT UNION DEDUCTIONS	0.00
21390	000	000	00000	000	NEA TEA WCEA DUES	0.00
21392	000	000	00000	000	OTHER P/R DED.-MED PUT PLUS	0.00
21500	000	000	00000	000	DUE TO OTHER FUNDS	0.00
21510	000	000	00000	000	DUE TO PRIMARY GOVERNMENT	0.00
21600	000	000	00000	000	DUE TO GENERAL GOVERNMENT	0.00
21900	000	000	00000	000	DUE TO PTO	0.00
21900	000	003	00000	000		0.00
21900	000	995	00000	000		0.00
29940	000	000	00000	000	DEFERRED CURRENT PROP. TAXES	14,107,442.00CR
29945	000	000	00000	000	DEF. DELINQUENT PROPERTY TAXES	331,549.00CR
-----						17,114,769.54CR
						=====

Q Equity						
34110	000	000	00000	000	PURCHASE ORDERS PAYABLE	0.00
34111	000	000	00000	000	RESERVE FOR ENCUMBRANCE	0.00
34120	000	000	00000	000	ENCUMBRANCE PRIOR YEAR	0.00
34240	000	000	00000	000	PRE-PAID ITEMS	0.00
34555	000	000	00000	000	RESTRICTED FOR EDUCATION	51,619.00CR
34560	000	000	00000	000	RESTRICTED FOR EDUCATION - CL	1,284.70CR
34587	000	000	00000	000	RESTRCT FOR HYBRID RETIR SRT	922,238.00CR
34755	000	000	00000	000	ASSIGNED FOR EDUCATION - NISWO	0.00
34760	000	000	00000	000	ASSIGNED FOR INSTRUCTION - RET	0.00

Account Level						Amount
Acct	Obj	Prj	Loc	Prg	Description	
Q					Equity	
34765	000	000	00000	000	ASSIGNED FOR SUPPORT SERVICES	6,069,342.00CR
34770	000	000	00000	000	ASSIGNED FOR OPERATION NON-INS	0.00
34775	000	000	00000	000	ASSIGNED FOR CAPITAL OUTLAY	0.00
34780	000	000	00000	000	ASSIGNED FOR EDUCATION - CASH	3,015,000.00CR
39000	000	000	00000	000	REV EXP SUMMARY FLOW THROUGH	20,295,695.30CR
39000	000	001	00000	000		0.00
39000	000	003	00000	000		0.00
39000	000	100	00000	000		0.00
39000	000	995	00000	000		1,065.23
39999	000	000	00000	000	UNDESIGNATED FUND BALANCE	0.00
-----						30,354,113.77CR
						=====

Grand Asset Totals	47,468,883.31
Grand Liability Totals	17,114,769.54CR
Grand Equity Totals	30,354,113.77CR
Grand Totals	0.00

Number of Accounts: 106

***** End of report *****

		CHECK CHECK					
FND	ACCT	OBJ	PRJ	NUMBER	DATE	VENDOR	AMOUNT
142	72220	790	900	142235871	02/11/2026	ADAPTIVE MALL	881.94
142	71100	429	100	142235872	02/11/2026	AMAZON CAPITAL SERVI	47.94
142	71100	429	100	142235872	02/11/2026	AMAZON CAPITAL SERVI	673.86
142	71100	429	160	142235872	02/11/2026	AMAZON CAPITAL SERVI	719.98
142	71200	499	900	142235872	02/11/2026	AMAZON CAPITAL SERVI	49.95
142	71200	725	900	142235874	02/11/2026	GOVCONNECTION, INC	2,222.70
142	72220	790	900	142235874	02/11/2026	GOVCONNECTION, INC	1,336.68
142	71200	312	900	142235875	02/11/2026	GRACE REHABILITATION	16,710.00 <i>Sped OT/PT</i>
142	72210	355	010	142235876	02/11/2026	LADY BROYLES, LISA	31.90
142	71300	499	800	142235877	02/11/2026	NATIONAL RESTAURANT	750.00
142	71300	499	800	142235878	02/11/2026	NCCER	2.25
142	71300	499	800	142235878	02/11/2026	NCCER	60.00
142	71300	499	800	142235878	02/11/2026	NCCER	200.00
142	71300	499	800	142235878	02/11/2026	NCCER	1,440.00
142	71300	499	800	142235878	02/11/2026	NCCER	300.00
142	72220	499	900	142235880	02/11/2026	RIVERSIDE INSIGHTS	180.00
142	71100	429	100	142235881	02/11/2026	SCHOLASTIC INC	115.50
142	72210	355	010	142235883	02/11/2026	WHITAKER, JERRY	65.25
142	72220	524	900	142236032	02/20/2026	BARNETT, EMILEE	255.00
142	72220	524	896	142236033	02/20/2026	BUREAU OF ED AND RES	14,125.00 <i>Sped Conference Fees</i>
142	71300	471	800	142236034	02/20/2026	COMPTIA	295.00
142	72220	524	900	142236035	02/20/2026	CONNER, CHARLES	255.00
142	72130	599	800	142236036	02/20/2026	DBHS HEALTH SCIENCE	1,873.00
142	72130	599	800	142236037	02/20/2026	DBHS SKILLS USA	1,325.00
142	72130	599	800	142236038	02/20/2026	DCHS HEALTH SCIENCE	1,648.00
142	72130	599	800	142236039	02/20/2026	DCHS SKILLS USA	2,644.00
142	72220	524	900	142236040	02/20/2026	DRINNON, BROOKE	255.00
142	72220	524	900	142236041	02/20/2026	MCKEE, BRANDON	255.00
142	72220	524	900	142236042	02/20/2026	MOATES, JORDAN	255.00
142	72130	499	100	142236043	02/20/2026	OTC BRANDS INC	48.94
142	72220	499	900	142236044	02/20/2026	PRO-ED	829.40
142	72220	524	900	142236045	02/20/2026	WOLFE, JACKI	558.75
142	72220	524	900	142236045	02/20/2026	WOLFE, JACKI	246.80
142	72130	599	800	142236122	02/27/2026	DCHS FCCLA	782.00
142	72130	599	800	142236123	02/27/2026	DCHS FFA	1,742.00
142	72210	524	100	142236125	02/27/2026	GARST, ANGELA	130.00
142	72220	499	900	142236126	02/27/2026	ODP BUSINESS SOLUTIO	13.98
142	72220	499	900	142236126	02/27/2026	ODP BUSINESS SOLUTIO	29.18
142	72220	499	900	142236126	02/27/2026	ODP BUSINESS SOLUTIO	2,378.08
142	72210	524	100	142236128	02/27/2026	SIMONS, CATHERINE	130.00
Totals for checks							55,862.08

State Conference Expenses

FUND SUMMARY

<u>FUND</u>	<u>DESCRIPTION</u>	<u>BALANCE SHEET</u>	<u>REVENUE</u>	<u>EXPENSE</u>	<u>TOTAL</u>
142	SCHOOL FEDERAL PROJECTS	0.00	0.00	55,862.08	55,862.08
***	Fund Summary Totals ***	0.00	0.00	55,862.08	55,862.08

***** End of report *****

Fnd T Acct	Obj Prj Loc	Prg	Account Level Description	2025-26 Budget	February 2025-26 Monthly Activity	2025-26 FYTD Activity	Encumbered Amount	Unexpended Balance - YTD Act	2025-26 FYTD %
010			CONSOLIDATED ADMINISTRATION						
142 E 72210 105 010 00001 000			SUPERVISOR/DIRECTOR	55,100.00	0.00	0.00	0.00	55,100.00	0.00
142 E 72210 162 010 00001 000			CLERICAL PERSONNEL	62,748.00	4,648.00	41,832.00	0.00	20,916.00	66.67
142 E 72210 189 010 00000 000			OTHER SALARIES & WAGES	47,397.24	0.00	0.00	0.00	47,397.24	0.00
142 E 72210 201 010 00000 000				7,306.58	0.00	0.00	0.00	7,306.58	0.00
142 E 72210 201 010 00001 000			SOCIAL SECURITY	0.00	288.18	2,593.61	0.00	-2,593.61	0.00
142 E 72210 204 010 00000 000				11,455.73	0.00	0.00	0.00	11,455.73	0.00
142 E 72210 204 010 00001 000			STATE RETIREMENT	0.00	613.08	5,517.71	0.00	-5,517.71	0.00
142 E 72210 207 010 00000 000				9,468.00	0.00	0.00	0.00	9,468.00	0.00
142 E 72210 212 010 00000 000				2,524.45	0.00	0.00	0.00	2,524.45	0.00
142 E 72210 212 010 00001 000			EMPLOYER MEDICARE	0.00	67.40	606.60	0.00	-606.60	0.00
142 E 72210 355 010 00000 000			TRAVEL	10,000.00	97.15	412.15	0.00	9,587.85	4.12
142 E 72210 499 010 00000 000			OTHER SUPPLIES AND MATERIALS	10,000.00	0.00	1,690.73	0.00	8,309.27	16.91
142 E 72210 524 010 00000 000			IN SERVICE / STAFF DEVELOPMENT	10,200.00	0.00	6,302.24	0.00	3,897.76	61.79
142 E 99100 504 010 00008 000			INDIRECT COST	2,000.00	0.00	0.00	0.00	2,000.00	0.00
	010			228,200.00	5,713.81	58,955.04	0.00	169,244.96	25.83

Fnd T Acct	Obj Prj Loc	Prg	Account Level Description	2025-26 Budget	February 2025-26 Monthly Activity	2025-26 FYTD Activity	Encumbered Amount	Unexpended Balance - YTD Act	2025-26 FYTD %
100			TITLE I						
142 E 71100	116 100	00000 000	TEACHERS	905,773.00	75,481.14	452,886.84	0.00	452,886.16	50.00
142 E 71100	163 100	00000 000	EDUCATIONAL ASSISTANTS	178,627.85	12,621.69	41,303.46	0.00	137,324.39	23.12
142 E 71100	201 100	00000 000	SOCIAL SECURITY	67,232.85	5,040.35	28,225.14	0.00	39,007.71	41.98
142 E 71100	204 100	00000 000	STATE RETIREMENT	79,613.23	5,258.11	30,236.76	0.00	49,376.47	37.98
142 E 71100	207 100	00000 000	MEDICAL INSURANCE	286,188.00	24,900.40	128,904.40	0.00	157,283.60	45.04
142 E 71100	212 100	00000 000	EMPLOYER MEDICARE	15,723.81	1,178.80	6,601.07	0.00	9,122.74	41.98
142 E 71100	429 100	00000 000	INSTRUCTIONAL SUPPLIES & MATER	33,159.40	837.30	10,824.05	0.00	22,335.35	32.64
142 E 72130	189 100	00000 000	OTHER SALARIES & WAGES	9,000.00	-132.00	4,455.00	0.00	4,545.00	49.50
142 E 72130	201 100	00000 000	SOCIAL SECURITY	558.00	-8.18	257.25	0.00	300.75	46.10
142 E 72130	204 100	00000 000	STATE RETIREMENT	810.00	-7.62	273.03	0.00	536.97	33.71
142 E 72130	212 100	00000 000	EMPLOYER MEDICARE	130.50	-1.91	60.18	0.00	70.32	46.11
142 E 72130	499 100	00000 000	OTHER SUPPLIES AND MATERIALS	18,000.00	48.94	3,875.76	0.00	14,124.24	21.53
142 E 72130	599 100	00000 000	OTHER CHARGES	5,000.00	0.00	0.00	0.00	5,000.00	0.00
142 E 72210	189 100	00000 000	OTHER SALARIES & WAGES	29,700.00	3,828.00	11,137.50	0.00	18,562.50	37.50
142 E 72210	201 100	00000 000	SOCIAL SECURITY	1,023.00	85.12	223.77	0.00	799.23	21.87
142 E 72210	204 100	00000 000	STATE RETIREMENT	1,188.00	89.57	212.20	0.00	975.80	17.86
142 E 72210	212 100	00000 000	EMPLOYER MEDICARE	727.65	55.31	160.69	0.00	566.96	22.08
142 E 72210	524 100	00000 000	IN SERVICE / STAFF DEVELOPMENT	50,000.00	260.00	8,532.05	0.00	41,467.95	17.06
142 E 72210	599 100	00000 000	OTHER CHARGES	154,293.25	0.00	0.00	0.00	154,293.25	0.00
142 E 99100	504 100	00008 000	INDIRECT COST	10,000.00	0.00	0.00	0.00	10,000.00	0.00
	100			1,846,748.54	129,535.02	728,169.15	0.00	1,118,579.39	39.43

Fnd T Acct	Obj Prj Loc	Prg	Account Level Description	2025-26 Budget	February 2025-26 Monthly Activity	2025-26 FYTD Activity	Encumbered Amount	Unexpended Balance - YTD Act	2025-26 FYTD %
160			TITLE I-D						
142 E 71100 399 160 00000 000			OTHER CONTRACTED SERVICE	7,650.00	0.00	0.00	0.00	7,650.00	0.00
142 E 71100 429 160 00000 000			INSTRUCTIONAL SUPPLIES & MATER	20,378.02	719.98	10,529.98	0.00	9,848.04	51.67
142 E 71100 499 160 00000 000			OTHER SUPPLIES AND MATERIALS	18,121.40	0.00	17,966.38	0.00	155.02	99.14
142 E 71100 599 160 00000 000			OTHER CHARGES	8,000.00	0.00	0.00	0.00	8,000.00	0.00
142 E 72210 524 160 00000 000			IN-SERVICE / STAFF DEVELOPMENT	9,000.00	0.00	1,166.20	0.00	7,833.80	12.96
142 E 99100 504 160 00000 000			INDIRECT COST	500.00	0.00	0.00	0.00	500.00	0.00
	160			63,649.42	719.98	29,662.56	0.00	33,986.86	46.60

Fnd T Acct	Obj Prj Loc	Prg	Account Level Description	2025-26 Budget	February 2025-26 Monthly Activity	2025-26 FYTD Activity	Encumbered Amount	Unexpended Balance - YTD Act	2025-26 FYTD %
200			TITLE II - A						
142 E 72210 138 200 00000 000			INSTR COMPUTER PERSONNEL	73,556.00	0.00	24,518.68	0.00	49,037.32	33.33
142 E 72210 138 200 00010 000			INSTR COMPUTER PERSONNEL	0.00	0.00	6,129.67	0.00	-6,129.67	0.00
142 E 72210 189 200 00000 000			OTHER SALARIES & WAGES	115,776.83	6,066.50	36,399.00	0.00	79,377.83	31.44
142 E 72210 201 200 00000 000			SOCIAL SECURITY	9,073.95	364.16	3,580.13	0.00	5,493.82	39.46
142 E 72210 201 200 00010 000				0.00	0.00	348.65	0.00	-348.65	0.00
142 E 72210 204 200 00000 000			STATE RETIREMENT	8,444.62	350.04	3,514.96	0.00	4,929.66	41.62
142 E 72210 204 200 00010 000				0.00	0.00	353.68	0.00	-353.68	0.00
142 E 72210 207 200 00000 000			MEDICAL INSURANCE	26,220.00	728.40	11,532.00	0.00	14,688.00	43.98
142 E 72210 207 200 00010 000				0.00	0.00	1,802.40	0.00	-1,802.40	0.00
142 E 72210 212 200 00000 000			EMPLOYER MEDICARE	2,745.33	85.17	837.30	0.00	1,908.03	30.50
142 E 72210 212 200 00010 000				0.00	0.00	81.54	0.00	-81.54	0.00
142 E 72210 524 200 00000 000			IN SERVICE / STAFF DEVELOPMENT	157,382.03	0.00	26,167.80	0.00	131,214.23	16.63
142 E 99100 504 200 00008 000			INDIRECT COST	5,000.00	0.00	0.00	0.00	5,000.00	0.00
	200			398,198.76	7,594.27	115,265.81	0.00	282,932.95	28.95

Account Level						2025-26	February 2025-26	2025-26	Encumbered	Unexpended	2025-26
Fnd T Acct	Obj Prj Loc	Prg	Description	Budget	Monthly Activity	FYTD Activity	Amount	Balance - YTD Act	FYTD %		
300 TITLE III											
142 E 71100 429 300 00000 000	INSTRUCTIONAL SUPPLIES & MATER					5,928.64	0.00	0.00	0.00	5,928.64	0.00
142 E 72130 499 300 00000 000	OTHER SUPPLIES AND MATERIALS					3,000.00	0.00	0.00	0.00	3,000.00	0.00
142 E 72210 524 300 00000 000	IN SERVICE / STAFF DEVELOPMENT					4,000.00	0.00	0.00	0.00	4,000.00	0.00
300						12,928.64	0.00	0.00	0.00	12,928.64	0.00

Fnd T Acct	Obj Prj Loc	Prg	Account Level Description	2025-26 Budget	February 2025-26 Monthly Activity	2025-26 FYTD Activity	Encumbered Amount	Unexpended Balance - YTD Act	2025-26 FYTD %
440			TITLE IV						
142 E 71150 116 440 00000 000			TEACHERS	47,410.44	0.00	0.00	0.00	47,410.44	0.00
142 E 71150 212 440 00000 000			MEDICARE	687.44	0.00	0.00	0.00	687.44	0.00
142 E 72130 123 440 00000 000			GUIDANCE PERSONNEL	59,388.20	4,813.34	28,880.04	0.00	30,508.16	48.63
142 E 72130 201 440 00000 000			SOCIAL SECURITY	3,682.06	272.03	1,636.38	0.00	2,045.68	44.44
142 E 72130 204 440 00000 000			STATE RETIREMENT	5,344.94	433.20	2,599.20	0.00	2,745.74	48.63
142 E 72130 207 440 00000 000			MEDICAL INSURANCE	16,380.00	1,638.00	9,516.00	0.00	6,864.00	58.10
142 E 72130 212 440 00000 000			EMPLOYER MEDICARE	861.14	63.62	382.68	0.00	478.46	44.44
142 E 72130 524 440 00000 000			IN SERVICE / STAFF DEVELOPMENT	2,400.00	0.00	2,337.60	0.00	62.40	97.40
142 E 72250 524 440 00000 000			IN-SERVICE / STAFF DEVELOPMENT	5,478.75	0.00	2,304.60	0.00	3,174.15	42.06
142 E 99100 504 440 00000 000			INDIRECT COST	1,000.00	0.00	0.00	0.00	1,000.00	0.00
	440			142,632.97	7,220.19	47,656.50	0.00	94,976.47	33.41

Account Level						2025-26	February 2025-26	2025-26	Encumbered	Unexpended	2025-26
Fnd T Acct	Obj Prj Loc	Prg	Description	Budget	Monthly Activity	FYTD Activity	Amount	Balance - YTD Act	FYTD %		
800 CARL PERKINS											
142 E 71300 189 800 00021 000	OTHER SALARIES & WAGES					5,329.20	0.00	0.00	0.00	5,329.20	0.00
142 E 71300 201 800 00021 000	SOCIAL SECURITY					330.41	0.00	0.00	0.00	330.41	0.00
142 E 71300 204 800 00021 000	STATE RETIREMENT					338.94	0.00	0.00	0.00	338.94	0.00
142 E 71300 207 800 00021 000	MEDICAL INSURANCE					164.40	0.00	0.00	0.00	164.40	0.00
142 E 71300 212 800 00021 000	EMPLOYER MEDICARE					77.27	0.00	0.00	0.00	77.27	0.00
142 E 71300 471 800 00000 000	SOFTWARE					62,000.00	295.00	65,822.83	0.00	-3,822.83	106.17
142 E 71300 499 800 00000 000	OTHER SUPPLIES AND MATERIALS					32,518.14	2,752.25	31,787.25	0.00	730.89	97.75
142 E 71300 730 800 00000 000	VOCATIONAL INSTRUCTION EQUIPME					13,000.00	0.00	8,852.64	0.00	4,147.36	68.10
142 E 72130 524 800 00000 000	IN SERVICE / STAFF DEVELOPMENT					18,300.21	0.00	12,914.60	0.00	5,385.61	70.57
142 E 72130 599 800 00000 000	OTHER CHARGES					11,000.00	10,014.00	10,394.00	0.00	606.00	94.49
800						143,058.57	13,061.25	129,771.32	0.00	13,287.25	90.71

Account Level		2025-26	February 2025-26	2025-26	Encumbered	Unexpended	2025-26
Fnd T Acct	Obj Prj Loc Prg Description	Budget	Monthly Activity	FYTD Activity	Amount	Balance - YTD Act	FYTD %
801	CARL PERKINS RESERVE GRANT						
142 E 71300 189 801 00000 000	OTHER SALARIES AND WAGES	1,320.00	0.00	0.00	0.00	1,320.00	0.00
142 E 71300 429 801 00000 000	INSTRUCTIONAL SUPPLIES & MATRI	16,900.00	0.00	0.00	0.00	16,900.00	0.00
142 E 71300 499 801 00000 000	OTHER SUPPLIES AND MATERIALS	24,180.00	0.00	0.00	0.00	24,180.00	0.00
142 E 71300 730 801 00000 000	VOCATIONAL INSTRUCTION EQUIP	7,600.00	0.00	0.00	0.00	7,600.00	0.00
	801	50,000.00	0.00	0.00	0.00	50,000.00	0.00

Fnd T Acct		Obj Prj Loc	Prg	Account Level Description	2025-26 Budget	February Monthly Activity	2025-26 FYTD Activity	Encumbered Amount	Unexpended Balance - YTD Act	2025-26 FYTD %
896		IDEA PART SYSTEMIC CHANGE K-12								
142	E	71200	116 896	00000 000	TEACHERS	77,600.00	0.00	27,725.00	0.00	49,875.00 35.73
142	E	71200	195 896	00000 000	CERTIFIED SUBSTITUTE TEACHERS	1.00	0.00	0.00	0.00	1.00 0.00
142	E	71200	201 896	00000 000	SOCIAL SECURITY	4,815.00	0.00	1,704.45	0.00	3,110.55 35.40
142	E	71200	204 896	00000 000		7,760.00	0.00	1,931.14	0.00	5,828.86 24.89
142	E	71200	212 896	00000 000	MEDICARE	1,125.50	0.00	398.70	0.00	726.80 35.42
142	E	71200	299 896	00000 000	OTHER FRINGE BENEFITS	315.00	0.00	0.00	0.00	315.00 0.00
142	E	71200	429 896	00000 000	SUPPLIES & MATERIALS	2,500.00	0.00	0.00	0.00	2,500.00 0.00
142	E	72220	524 896	00000 000	IN-SERVICE / STAFF DEVELOPMENT	5,883.50	14,125.00	17,169.40	0.00	-11,285.90 291.82
					896	100,000.00	14,125.00	48,928.69	0.00	51,071.31 48.93

Account Level							2025-26	February 2025-26	2025-26	Encumbered	Unexpended	2025-26
Fnd T Acct	Obj Prj Loc	Prg	Description	Budget	Monthly Activity	FYTD Activity	Amount	Balance - YTD Act	FYTD %			
898			IDEA PART SYSTEMIC CHANGE PRES									
142 E 71200 116 898 00000 000			TEACHERS	5,000.00	2,425.50	2,904.00	0.00	2,096.00	58.08			
142 E 71200 201 898 00000 000			SOCIAL SECURITY	310.00	150.37	180.07	0.00	129.93	58.09			
142 E 71200 204 898 00000 000			STATE RETIREMENT	625.00	224.44	259.52	0.00	365.48	41.52			
142 E 71200 212 898 00000 000			MEDICARE	75.00	35.18	42.14	0.00	32.86	56.19			
142 E 71200 429 898 00000 000			INSTRUCTIONAL SUPPLIES & MAT.	5,000.00	0.00	2,979.93	0.00	2,020.07	59.60			
142 E 72220 524 898 00000 000			IN-SERVICE / STAFF DEVELOPMENT	5,000.00	0.00	0.00	0.00	5,000.00	0.00			
			898	16,010.00	2,835.49	6,365.66	0.00	9,644.34	39.76			

Fnd T Acct	Obj Prj Loc	Prg Description	2025-26 Budget	February 2025-26 Monthly Activity	2025-26 FYTD Activity	Encumbered Amount	Unexpended Balance - YTD Act	2025-26 FYTD %
900		IDEA PART- B						
142 E 71200 116 900 00000 000		TEACHERS	140,379.00	11,047.01	66,282.06	0.00	74,096.94	47.22
142 E 71200 163 900 00000 000		EDUCATIONAL ASSISTANTS	1,062,380.50	87,544.88	542,379.56	0.00	520,000.94	51.05
142 E 71200 171 900 00000 000		SPEECH PATHOLOGIST	100,000.00	4,852.84	29,117.04	0.00	70,882.96	29.12
142 E 71200 189 900 00000 000		OTHER SALARIES & WAGES	5,000.00	0.00	0.00	0.00	5,000.00	0.00
142 E 71200 201 900 00000 000		SOCIAL SECURITY	82,000.00	6,088.49	37,639.28	0.00	44,360.72	45.90
142 E 71200 204 900 00000 000		STATE RETIREMENT	265,000.00	11,869.65	74,201.12	0.00	190,798.88	28.00
142 E 71200 207 900 00000 000		MEDICAL INSURANCE	500,000.00	25,762.40	143,462.40	0.00	356,537.60	28.69
142 E 71200 212 900 00000 000		EMPLOYER MEDICARE	21,000.00	1,423.94	8,802.78	0.00	12,197.22	41.92
142 E 71200 312 900 00000 000		CONTRACTS W PRIVATE AGENCIES	100,000.00	16,710.00	100,693.60	0.00	-693.60	100.69
142 E 71200 429 900 00000 000		INSTRUCTIONAL SUPPLIES & MAT.	25,000.00	0.00	-423.63	0.00	25,423.63	-1.69
142 E 71200 499 900 00000 000		OTHER SUPPLIES AND MATERIALS	5,000.00	49.95	525.22	0.00	4,474.78	10.50
142 E 71200 725 900 00000 000		SPECIAL EDUCATION EQUIPMENT	20,000.00	2,222.70	3,272.88	0.00	16,727.12	16.36
142 E 72220 189 900 00000 000		OTHER SALARIES & WAGES	140,000.00	6,159.09	36,954.54	0.00	103,045.46	26.40
142 E 72220 201 900 00000 000		SOCIAL SECURITY	9,000.00	381.86	2,291.16	0.00	6,708.84	25.46
142 E 72220 204 900 00000 000		STATE RETIREMENT	18,000.00	554.32	3,325.90	0.00	14,674.10	18.48
142 E 72220 207 900 00000 000		MEDICAL INSURANCE	32,600.00	0.00	0.00	0.00	32,600.00	0.00
142 E 72220 212 900 00000 000		EMPLOYER MEDICARE	2,100.00	89.31	535.86	0.00	1,564.14	25.52
142 E 72220 355 900 00000 000		TRAVEL	15,000.00	0.00	0.00	0.00	15,000.00	0.00
142 E 72220 429 900 00000 000		Instructional Supplies & Mat.	0.00	0.00	-101.00	0.00	101.00	0.00
142 E 72220 499 900 00000 000		OTHER SUPPLIES AND MATERIALS	10,000.00	3,430.64	11,768.61	0.00	-1,768.61	117.69
142 E 72220 524 900 00000 000		IN SERVICE / STAFF DEVELOPMENT	40,246.29	2,080.55	11,581.70	0.00	28,664.59	28.78
142 E 72220 790 900 00000 000		OTHER EQUIPMENT	5,000.00	2,218.62	5,000.62	0.00	-0.62	100.01
142 E 72710 146 900 00020 000		BUS DRIVERS	200,565.00	19,222.80	117,223.05	0.00	83,341.95	58.45
142 E 72710 189 900 00000 000		OTHER SALARIES AND WAGES	20,668.00	660.97	5,036.77	0.00	15,631.23	24.37
142 E 72710 201 900 00000 000			13,716.45	40.98	312.28	0.00	13,404.17	2.28
142 E 72710 201 900 00020 000		SOCIAL SECURITY	0.00	1,021.80	6,260.16	0.00	-6,260.16	0.00
142 E 72710 204 900 00020 000		STATE RETIREMENT	27,654.15	2,535.49	15,325.91	0.00	12,328.24	55.42
142 E 72710 207 900 00020 000		MEDICAL INSURANCE	100,000.00	5,461.20	31,725.60	0.00	68,274.40	31.73
142 E 72710 212 900 00000 000			3,207.90	9.58	73.02	0.00	3,134.88	2.28
142 E 72710 212 900 00020 000		EMPLOYER MEDICARE	0.00	259.19	1,585.71	0.00	-1,585.71	0.00
142 E 72710 599 900 00000 000		OTHER CHARGES	2,000.00	0.00	2,040.00	0.00	-40.00	102.00
	900		2,965,517.29	211,698.26	1,256,892.20	0.00	1,708,625.09	42.38

Account Level		2025-26	February 2025-26	2025-26	Encumbered	Unexpended	2025-26
Fnd T Acct	Obj Prj Loc Prg Description	Budget	Monthly Activity	FYTD Activity	Amount	Balance - YTD Act	FYTD %
910	IDEA PRESCHOOL						
142 E 71200 163 910 00000 000	EDUCATIONAL ASSISTANTS	92,858.00	2,891.53	17,583.20	0.00	75,274.80	18.94
142 E 71200 189 910 00000 000	OTHER SALARIES AND WAGES	5,432.37	0.00	0.00	0.00	5,432.37	0.00
142 E 71200 201 910 00000 000	SOCIAL SECURITY	4,778.00	168.30	1,025.50	0.00	3,752.50	21.46
142 E 71200 204 910 00000 000	STATE RETIREMENT	8,307.00	381.39	2,319.22	0.00	5,987.78	27.92
142 E 71200 207 910 00000 000	MEDICAL INSURANCE	21,000.00	728.40	4,231.20	0.00	16,768.80	20.15
142 E 71200 212 910 00000 000	EMPLOYER MEDICARE	1,267.00	39.36	239.84	0.00	1,027.16	18.93
142 E 71200 312 910 00000 000	CONTRACTS W PRIVATE AGENCIES	3,575.00	0.00	1,869.01	0.00	1,705.99	52.28
142 E 71200 429 910 00000 000	INSTRUCTIONAL SUPPLIES & MATER	9,000.00	0.00	5,690.85	0.00	3,309.15	63.23
142 E 72220 499 910 00000 000	OTHER SUPPLIES AND MATERIALS	5,000.00	0.00	2,226.93	0.00	2,773.07	44.54
142 E 72220 524 910 00000 000	IN SERVICE / STAFF DEVELOPMENT	10,000.00	0.00	0.00	0.00	10,000.00	0.00
142 E 72220 599 910 00000 000	OTHER CHARGES	920.00	0.00	0.00	0.00	920.00	0.00
	910	162,137.37	4,208.98	35,185.75	0.00	126,951.62	21.70

Account Level		2025-26	February 2025-26	2025-26	Encumbered	Unexpended	2025-26
Fnd T Acct	Obj Prj Loc Prg Description	Budget	Monthly Activity	FYTD Activity	Amount	Balance - YTD Act	FYTD %
951	HQIM-PARTICIPANT LITERACY NETW						
142 E 71100 399 951 00000 000	OTHER CONTRACTED SERVICE	72,800.00	0.00	0.00	0.00	72,800.00	0.00
142 E 71100 429 951 00000 000	SUPPLIES & MATERIALS	1,500.00	0.00	0.00	0.00	1,500.00	0.00
142 E 72210 399 951 00000 000	OTHER CONTRACTED SERVICE	0.00	0.00	36,400.00	0.00	-36,400.00	0.00
	951	74,300.00	0.00	36,400.00	0.00	37,900.00	48.99

Account Level						2025-26	February	2025-26	2025-26	Encumbered	Unexpended	2025-26
Fnd T	Acct	Obj	Prj	Loc	Prg Description	Budget	Monthly Activity	FYTD Activity	Amount	Balance -	YTD Act	FYTD %
953					EARLY LITERACY PRE-K TEACHER S							
142 E	73400	189	953	00008	000 OTHER SALARIES AND WAGES	0.00	0.00	10,000.00	0.00		-10,000.00	0.00
			953			0.00	0.00	10,000.00	0.00		-10,000.00	0.00

Number of Accounts: 140

***** End of report *****

Fnd T Acct	Obj Prj Loc	Prg	Account Level Description	Amount
A			Asset	
142 A 11130	000 000 000000	000	CASH IN BANK-PAYROLL	0.00
142 A 11130	000 100 000000	000	CASH IN BANK-PAYROLL	0.00
142 A 11130	000 440 000000	000	CASH IN BANK-PAYROLL	0.00
142 A 11130	---	---	-----	0.00
142 A 11140	000 000 000000	000	CASH WITH TRUSTEE	0.00
142 A 11140	000 000 000000	142	CASH WITH TRUSTEE	0.00
142 A 11140	000 000 99141	141		787.49CR
142 A 11140	000 000 99142	142		1,492,340.94
142 A 11140	000 010 000000	142	CASH WITH TRUSTEE - CON ADMIN	0.00
142 A 11140	000 010 99141	141		0.00
142 A 11140	000 010 99142	142		9,441.76CR
142 A 11140	000 100 000000	000	CASH WITH TRUSTEE	0.00
142 A 11140	000 100 000000	142	CASH WITH TRUSTEE - TITLE I	0.00
142 A 11140	000 100 99141	141		0.00
142 A 11140	000 100 99142	142		140,036.66CR
142 A 11140	000 101 99142	142		0.00
142 A 11140	000 160 000000	000	TITLE I-D	0.00
142 A 11140	000 160 99141	141		0.00
142 A 11140	000 160 99142	142		719.98CR
142 A 11140	000 171 99142	142		0.00
142 A 11140	000 172 99142	142		0.00
142 A 11140	000 200 000000	142	CASH WITH TRUSTEE - TITLE II-A	0.00
142 A 11140	000 200 99141	141		0.00
142 A 11140	000 200 99142	142		9,822.26CR
142 A 11140	000 300 000000	142	CASH WITH TRUSTEE - TITLE III	0.00
142 A 11140	000 440 000000	141	CASH WITH TRUSTEE	0.00
142 A 11140	000 440 99141	141		33,292.83
142 A 11140	000 440 99142	142		42,115.99CR
142 A 11140	000 480 000000	142	CASH WITH TRUSTEE - FTTT DISCR	0.00
142 A 11140	000 580 000000	142	CASH WITH TRUSTEE - FTTT	0.00
142 A 11140	000 700 99142	142		0.00
142 A 11140	000 705 99142	142		0.00
142 A 11140	000 720 99142	142		0.00
142 A 11140	000 800 000000	142	CASH WITH TRUSTEE - CARL PERKI	0.00
142 A 11140	000 800 99141	141		0.00
142 A 11140	000 800 99142	142		35,398.89CR
142 A 11140	000 801 000000	142	CASH WITH TRUSTEE - CTE RESERV	0.00
142 A 11140	000 801 99142	142		0.00
142 A 11140	000 802 99142	142		0.00
142 A 11140	000 803 99142	142		0.00
142 A 11140	000 890 99142	142		229.54
142 A 11140	000 891 000000	142	CASH WITH TRUSTEE - STATE DISC	0.00
142 A 11140	000 891 99142	142		0.00
142 A 11140	000 892 000000	142	CASH WITH TRUSTEE - DISC PRESC	0.00
142 A 11140	000 892 99142	142		0.00
142 A 11140	000 893 000000	142	CASH WITH TRUSTEE - IDEA DISC	0.00
142 A 11140	000 893 99142	142		0.00
142 A 11140	000 894 000000	142	CASH WITH TRUSTEE - FS GRAY	0.00
142 A 11140	000 894 99142	142		0.00
142 A 11140	000 895 000000	142	CASH WITH TRUSTEE - FS JM	0.00
142 A 11140	000 895 99142	142		0.00
142 A 11140	000 896 000000	142	CASH WITH TRUSTEE - FS SS	0.00
142 A 11140	000 896 99142	142		51,364.04CR
142 A 11140	000 897 99142	142		0.00

Fnd T Acct	Obj Prj Loc	Prg	Account Level Description	Amount
A			Asset	
142 A 11140 000 898 99142 142				6,019.92CR
142 A 11140 000 899 99141 141				0.00
142 A 11140 000 899 99142 142				0.00
142 A 11140 000 900 00000 000			CASH WITH TRUSTEE-IDEA PART B	0.00
142 A 11140 000 900 00000 142			CASH WITH TRUSTEE-IDEA PART B	0.00
142 A 11140 000 900 99141 141				0.00
142 A 11140 000 900 99142 142				244,991.61CR
142 A 11140 000 901 00000 142			EDUCATION HANDICAPPED ACT - I	0.00
142 A 11140 000 901 99142 142				0.00
142 A 11140 000 902 00000 142			EDUCATION HANDICAPPED ACT - ID	0.00
142 A 11140 000 910 00000 142			CASH WITH TRUSTEE - IDEA PRESC	0.00
142 A 11140 000 910 99141 141				0.00
142 A 11140 000 910 99142 142				18,153.49CR
142 A 11140 000 911 99142 142				0.00
142 A 11140 000 912 99142 142				0.00
142 A 11140 000 930 99142 142				0.00
142 A 11140 000 931 99141 141				0.00
142 A 11140 000 931 99142 142				0.00
142 A 11140 000 932 99142 142				0.00
142 A 11140 000 933 99142 142				0.00
142 A 11140 000 934 99142 142				0.00
142 A 11140 000 935 99142 142				0.00
142 A 11140 000 936 99142 142				0.00
142 A 11140 000 937 99142 142				0.00
142 A 11140 000 938 99142 142				0.00
142 A 11140 000 939 99142 142				0.00
142 A 11140 000 940 99142 142				0.00
142 A 11140 000 941 99142 142				0.00
142 A 11140 000 950 99141 141				0.00
142 A 11140 000 950 99142 142				0.00
142 A 11140 000 951 99142 142				0.00
142 A 11140 000 952 99142 142				0.00
142 A 11140 000 953 99142 142				0.00
142 A 11140 --- --- ----- ---				967,011.22
142 A 11400 000 900 00000 142			DUE FROM OTHER FUNDS	0.00
142 A 11400 --- --- ----- ---				0.00
142 A 11410 000 000 00000 142				0.00
142 A 11410 --- --- ----- ---				0.00
142 A 11430 000 010 00000 142			DUE FROM OTHER GOVERNMENTS	0.00
142 A 11430 000 100 00000 142			DUE FROM OTHER GOVERNMENTS	0.00
142 A 11430 000 101 00000 142			DUE FROM OTHER GOVERNMENTS	0.00
142 A 11430 000 160 00000 142			DUE FROM OTHER GOVERNMENTS	0.00
142 A 11430 000 171 00000 142			DUE FROM OTHER GOVERNMENTS	0.00
142 A 11430 000 172 00000 142			ADAPTIVE LEARNING TECH. GRANT	0.00
142 A 11430 000 200 00000 142			DUE FROM OTHER GOVERNMENTS	0.00
142 A 11430 000 300 00000 142			DUE FROM OTHER GOVERNMENTS	0.00
142 A 11430 000 440 00000 142			DUE FROM OTHER GOVERNMENTS	0.00
142 A 11430 000 580 00000 142			DUE FROM OTHER GOVERNMENTS	0.00
142 A 11430 000 700 00000 142			ARP HOMELESS 2.0	0.00
142 A 11430 000 720 00000 142			DUE FROM OTHER GOVERNMENTS	0.00
142 A 11430 000 800 00000 142			DUE FROM OTHER GOVERNMENTS	0.00
142 A 11430 000 801 00000 142			DUE FROM OTHER GOVERNMENTS	0.00

Fnd T Acct	Obj Prj Loc	Prg	Account Level Description	Amount
A			Asset	
142 A 11430 000 802 00000 142			PERKINS-NEW SKILLS FOR YOUTH	0.00
142 A 11430 000 891 00000 142			DUE FROM OTHER GOVERNMENTS	0.00
142 A 11430 000 892 00000 142			DUE FROM OTHER GOVERNMENTS	0.00
142 A 11430 000 893 00000 142			DUE FROM OTHER GOVERNMENTS	0.00
142 A 11430 000 894 00000 142			Focus School Gray	0.00
142 A 11430 000 895 00000 142			Focus School JM	0.00
142 A 11430 000 896 00000 000			DUE FROM OTHER GOVERNMENTS	0.00
142 A 11430 000 896 00000 142			DUE FROM OTHER GOVERNMENTS	0.00
142 A 11430 000 898 00000 142			DUE FROM OTHER GOVERNMENTS	0.00
142 A 11430 000 900 00000 142			DUE FROM OTHER GOVERNMENTS	0.00
142 A 11430 000 901 00000 142			DUE FROM OTHER GOVERNMENTS	0.00
142 A 11430 000 910 00000 142			DUE FROM OTHER GOVERNMENTS	0.00
142 A 11430 000 911 00000 142			DUE FROM OTHER GOVERNMENTS	0.00
142 A 11430 000 930 00000 142			DUE FROM OTHER GOVERNMENTS	0.00
142 A 11430 000 931 00000 142			DUE FROM OTHER GOVERNMENTS	0.00
142 A 11430 000 933 00000 142			MATH IMPLEMENTATION SUPPORT GR	0.00
142 A 11430 000 934 00000 142			DUE FROM OTHER GOVERNMENTS	0.00
142 A 11430 000 935 00000 142			DUE FROM OTHER GOVERNMENTS	0.00
142 A 11430 000 937 00000 142			ESSER 3.0	0.00
142 A 11430 000 938 00000 142			BEST FOR ALL DISTRICT GRANT	0.00
142 A 11430 000 939 00000 142			DUE FROM OTHER GOVERNMENTS	0.00
142 A 11430 000 940 00000 142			EPIDEMIOOGY & LABORATORY ELC	0.00
142 A 11430 000 941 00000 142			DUE FROM OTHER GOVERNMENTS	0.00
142 A 11430 000 950 00000 142			CIVICS SEAL GRANT	0.00
142 A 11430 000 951 00000 142			HQIM LITERACY IMPLEMENTATION	0.00
142 A 11430 000 952 00000 142			EARLY LITERACY NETWORKS	0.00
142 A 11430 --- --- ----- ---				0.00
142 A 11440 000 000 00000 142			DUE FROM OTHER FUNDS	0.00
142 A 11440 000 010 00000 000			DUE FROM OTHER FUNDS-CON ADMIN	0.00
142 A 11440 000 100 00000 000			DUE FROM OTHER FUNDS	0.00
142 A 11440 000 160 00000 000			DUE FROM OTHER FUNDS	0.00
142 A 11440 000 200 00000 000			DUE FROM OTHER FUNDS	0.00
142 A 11440 000 440 00000 000			DUE FROM OTHER FUNDS	0.00
142 A 11440 000 800 00000 142			DUE FROM OTHER FUNDS-CTE BASIC	0.00
142 A 11440 000 890 00000 000			DUE FROM OTHER FUNDS	0.00
142 A 11440 000 891 00000 142			DUE FROM OTHER FUNDS-STATE DIS	0.00
142 A 11440 000 892 00000 000			DUE FROM OTHER FUNDS-DISC PREK	0.00
142 A 11440 000 895 00000 000			DUE FROM OTHER FUNDS-FS JMS	0.00
142 A 11440 000 896 00000 000			DUE FROM OTHER FUNDS-FS SS	0.00
142 A 11440 000 898 00000 000			DUE FROM OTHER FUNDS	0.00
142 A 11440 000 900 00000 000			DUE FROM OTHER FUNDS-IDEA B	0.00
142 A 11440 000 900 00000 142				0.00
142 A 11440 000 910 00000 000			DUE FROM OTHER FUNDS	0.00
142 A 11440 000 912 00000 000			DUE FROM OTHER FUNDS	0.00
142 A 11440 000 934 00000 142			DUE FROM OTHER FUNDS	0.00
142 A 11440 000 935 00000 000			DUE FROM OTHER FUNDS	0.00
142 A 11440 000 937 00000 000			DUE FROM OTHER FUNDS	0.00
142 A 11440 --- --- ----- ---				0.00
142 A 21100 000 000 00000 142			ACCOUNTS PAYABLE	0.00
142 A 21100 --- --- ----- ---				0.00
142 A 21500 000 000 00000 142			DUE TO OTHER FUNDS	0.00

						Account Level	Amount
Fnd	T	Acct	Obj	Prj	Loc	Prg Description	
						Asset	
142	A	21500	---	---	-----	---	0.00
142	A	-----	---	---	-----	---	967,011.22
							=====
						Liability	
142	L	21100	000	010	00000	000 ACCOUNTS PAYABLE	0.00
142	L	21100	000	100	00000	000 ACCOUNTS PAYABLE	0.00
142	L	21100	000	101	00000	000	0.00
142	L	21100	000	160	00000	000 TITLE I-D	0.00
142	L	21100	000	171	00000	000	0.00
142	L	21100	000	172	00000	000	0.00
142	L	21100	000	200	00000	000 ACCOUNTS PAYABLE	0.00
142	L	21100	000	440	00000	000 ACCOUNTS PAYABLE	0.00
142	L	21100	000	700	00000	000	0.00
142	L	21100	000	705	00000	000	0.00
142	L	21100	000	720	00000	000	0.00
142	L	21100	000	800	00000	000 ACCOUNTS PAYABLE	0.00
142	L	21100	000	801	00000	000 ACCOUNTS PAYABLE	0.00
142	L	21100	000	802	00000	000	0.00
142	L	21100	000	803	00000	000	0.00
142	L	21100	000	890	00000	000	0.00
142	L	21100	000	891	00000	000 ACCOUNTS PAYABLE	0.00
142	L	21100	000	892	00000	000 ACCOUNTS PAYABLE	0.00
142	L	21100	000	893	00000	000 ACCOUNTS PAYABLE	0.00
142	L	21100	000	894	00000	000 ACCOUNTS PAYABLE	0.00
142	L	21100	000	895	00000	000 ACCOUNTS PAYABLE	0.00
142	L	21100	000	896	00000	000 ACCOUNTS PAYABLE	0.00
142	L	21100	000	897	00000	000	0.00
142	L	21100	000	898	00000	000	0.00
142	L	21100	000	899	00000	000	0.00
142	L	21100	000	900	00000	000 ACCOUNTS PAYABLE	0.00
142	L	21100	000	901	00000	000	0.00
142	L	21100	000	910	00000	000 ACCOUNTS PAYABLE	0.00
142	L	21100	000	911	00000	000	0.00
142	L	21100	000	912	00000	000	0.00
142	L	21100	000	930	00000	000	0.00
142	L	21100	000	931	00000	000	0.00
142	L	21100	000	932	00000	000	0.00
142	L	21100	000	933	00000	000	0.00
142	L	21100	000	934	00000	000	0.00
142	L	21100	000	935	00000	000	0.00
142	L	21100	000	936	00000	000	0.00
142	L	21100	000	937	00000	000	0.00
142	L	21100	000	938	00000	000	0.00
142	L	21100	000	939	00000	000 FISCAL PRE-MONITORING SUPPORTS	0.00
142	L	21100	000	940	00000	000	0.00
142	L	21100	000	941	00000	000	0.00
142	L	21100	000	950	00000	000	0.00
142	L	21100	000	951	00000	000	0.00
142	L	21100	000	952	00000	000	0.00
142	L	21100	000	953	00000	000	0.00

Fnd T Acct	Obj Prj Loc	Prg	Account Level Description	Amount
L			Liability	
142 L 21100	---	---	-----	0.00
142 L 21200	000 100	00000 000	ACCRUED PAYROLL	0.00
142 L 21200	000 931	00000 000	ACCRUED PAYROLL	0.00
142 L 21200	000 934	00000 000	ACCRUED PAYROLL	0.00
142 L 21200	000 935	00000 000	ACCRUED PAYROLL	0.00
<hr/>				0.00
142 L 21200	---	---	-----	0.00
142 L 21310	000 000	00000 000		0.00
142 L 21310	000 010	00000 000	INCOME TAX WITHHELD AND UNPAID	0.00
142 L 21310	000 100	00000 000	INCOME TAX WITHHELD AND UNPAID	0.00
142 L 21310	000 160	00000 000	TITLE I-D	0.00
142 L 21310	000 200	00000 000	INCOME TAX WITHHELD AND UNPAID	0.00
142 L 21310	000 440	00000 000	INCOME TAX WITHHELD AND UNPAID	0.00
142 L 21310	000 580	00000 000	INCOME TAX WITHHELD AND UNPAID	0.00
142 L 21310	000 720	00000 000		0.00
142 L 21310	000 800	00000 000	INCOME TAX WITHHELD AND UNPAID	0.00
142 L 21310	000 890	00000 000		0.00
142 L 21310	000 891	00000 000	INCOME TAX WITHHELD AND UNPAID	0.00
142 L 21310	000 892	00000 000	INCOME TAX WITHHELD AND UNPAID	0.00
142 L 21310	000 894	00000 000	INCOME TAX WITHHELD AND UNPAID	0.00
142 L 21310	000 895	00000 000	INCOME TAX WITHHELD AND UNPAID	0.00
142 L 21310	000 896	00000 000	INCOME TAX WITHHELD AND UNPAID	0.00
142 L 21310	000 898	00000 000		0.00
142 L 21310	000 900	00000 000	INCOME TAX WITHHELD AND UNPAID	0.00
142 L 21310	000 901	00000 000		0.00
142 L 21310	000 910	00000 000	INCOME TAX WITHHELD AND UNPAID	0.00
142 L 21310	000 912	00000 000		0.00
142 L 21310	000 930	00000 000		0.00
142 L 21310	000 931	00000 000		0.00
142 L 21310	000 934	00000 000		0.00
142 L 21310	000 935	00000 000		0.00
142 L 21310	000 937	00000 000		0.00
142 L 21310	000 938	00000 000		0.00
142 L 21310	000 940	00000 000		0.00
142 L 21310	000 950	00000 000		0.00
<hr/>				0.00
142 L 21310	---	---	-----	0.00
142 L 21320	000 000	00000 000		0.00
142 L 21320	000 010	00000 000	SOCIAL SECURITY TAX	0.00
142 L 21320	000 100	00000 000	SOCIAL SECURITY TAX	0.00
142 L 21320	000 160	00000 000	TITLE I-D	0.00
142 L 21320	000 200	00000 000	SOCIAL SECURITY TAX	0.00
142 L 21320	000 440	00000 000	SOCIAL SECURITY TAX	0.00
142 L 21320	000 580	00000 000	SOCIAL SECURITY TAX	0.00
142 L 21320	000 720	00000 000		0.00
142 L 21320	000 800	00000 000	SOCIAL SECURITY TAX	0.00
142 L 21320	000 890	00000 000		0.00
142 L 21320	000 891	00000 000	SOCIAL SECURITY TAX	0.00
142 L 21320	000 894	00000 000	SOCIAL SECURITY TAX	0.00
142 L 21320	000 895	00000 000	SOCIAL SECURITY TAX	0.00
142 L 21320	000 896	00000 000	SOCIAL SECURITY TAX	0.00
142 L 21320	000 898	00000 000		0.00
142 L 21320	000 900	00000 000	SOCIAL SECURITY TAX	11.84CR
142 L 21320	000 901	00000 000		0.00
142 L 21320	000 910	00000 000	SOCIAL SECURITY TAX	11.84

Fnd T Acct	Obj Prj Loc	Prg	Account Level Description	Amount
L			Liability	
142 L 21320	000 912	00000 000		0.00
142 L 21320	000 930	00000 000		0.00
142 L 21320	000 931	00000 000		0.00
142 L 21320	000 934	00000 000		0.00
142 L 21320	000 935	00000 000		0.00
142 L 21320	000 937	00000 000		0.00
142 L 21320	000 938	00000 000		0.00
142 L 21320	000 940	00000 000		0.00
142 L 21320	000 950	00000 000		0.00
				<hr/>
142 L 21320	---	---	-----	0.00
142 L 21325	000 000	00000 000		0.00
142 L 21325	000 010	00000 000	EMPLOYEE MEDICARE DEDUCTION	0.00
142 L 21325	000 100	00000 000	EMPLOYEE MEDICARE DEDUCTION	0.00
142 L 21325	000 160	00000 000	TITLE I-D	0.00
142 L 21325	000 200	00000 000	EMPLOYEE MEDICARE DEDUCTION	0.00
142 L 21325	000 440	00000 000	EMPLOYEE MEDICARE DEDUCTION	0.00
142 L 21325	000 580	00000 000	EMPLOYEE MEDICARE DEDUCTION	0.00
142 L 21325	000 720	00000 000		0.00
142 L 21325	000 800	00000 000	EMPLOYEE MEDICARE DEDUCTION	0.00
142 L 21325	000 890	00000 000		0.00
142 L 21325	000 891	00000 000	EMPLOYEE MEDICARE DEDUCTION	0.00
142 L 21325	000 892	00000 000	EMPLOYEE MEDICARE DEDUCTION	0.00
142 L 21325	000 894	00000 000	EMPLOYEE MEDICARE DEDUCTION	0.00
142 L 21325	000 895	00000 000	EMPLOYEE MEDICARE DEDUCTION	0.00
142 L 21325	000 896	00000 000	EMPLOYEE MEDICARE DEDUCTION	0.00
142 L 21325	000 898	00000 000		0.00
142 L 21325	000 900	00000 000	EMPLOYEE MEDICARE DEDUCTION	2.76CR
142 L 21325	000 901	00000 000		0.00
142 L 21325	000 910	00000 000	EMPLOYEE MEDICARE DEDUCTION	2.76
142 L 21325	000 912	00000 000		0.00
142 L 21325	000 930	00000 000		0.00
142 L 21325	000 931	00000 000		0.00
142 L 21325	000 934	00000 000		0.00
142 L 21325	000 935	00000 000		0.00
142 L 21325	000 937	00000 000		0.00
142 L 21325	000 938	00000 000		0.00
142 L 21325	000 940	00000 000		0.00
142 L 21325	000 950	00000 000		0.00
				<hr/>
142 L 21325	---	---	-----	0.00
142 L 21330	000 000	00000 000		0.00
142 L 21330	000 010	00000 000	RETIREMENT CONTRIBUTIONS	919.62
142 L 21330	000 100	00000 000	RETIREMENT CONTRIBUTIONS	18,280.76
142 L 21330	000 160	00000 000	RETIREMENT CONTRIBUTIONS	0.00
142 L 21330	000 200	00000 000	RETIREMENT CONTRIBUTIONS	2,627.06
142 L 21330	000 440	00000 000	RETIREMENT CONTRIBUTIONS	1,747.74
142 L 21330	000 580	00000 000	RETIREMENT CONTRIBUTIONS	0.00
142 L 21330	000 720	00000 000		0.00
142 L 21330	000 800	00000 000	RETIREMENT CONTRIBUTIONS	0.00
142 L 21330	000 890	00000 000		0.00
142 L 21330	000 891	00000 000	RETIREMENT CONTRIBUTIONS	0.00
142 L 21330	000 892	00000 000		0.00
142 L 21330	000 894	00000 000		0.00
142 L 21330	000 895	00000 000	RETIREMENT CONTRIBUTIONS	0.00

Fnd T Acct	Obj Prj Loc	Prg	Account Level Description	Amount
L			Liability	
142 L 21330	000 896	00000 000		1,997.66
142 L 21330	000 898	00000 000		0.00
142 L 21330	000 900	00000 000	RETIREMENT CONTRIBUTIONS	32,822.36
142 L 21330	000 901	00000 000		0.00
142 L 21330	000 910	00000 000	RETIREMENT CONTRIBUTIONS	778.17
142 L 21330	000 912	00000 000		0.00
142 L 21330	000 930	00000 000		0.00
142 L 21330	000 931	00000 000		0.00
142 L 21330	000 934	00000 000		0.00
142 L 21330	000 935	00000 000		0.00
142 L 21330	000 937	00000 000		0.00
142 L 21330	000 938	00000 000		0.00
142 L 21330	000 940	00000 000		0.00
142 L 21330	000 950	00000 000		0.00
				<hr/>
142 L 21330	---	---	-----	59,173.37
142 L 21339	000 000	00000 000		0.00
142 L 21339	000 010	00000 000	STATE DENTAL PLAN	0.00
142 L 21339	000 100	00000 000	STATE DENTAL PLAN	3,204.43CR
142 L 21339	000 160	00000 000	STATE DENTAL PLAN	0.00
142 L 21339	000 200	00000 000	STATE DENTAL PLAN	353.77CR
142 L 21339	000 440	00000 000	STATE DENTAL PLAN	90.41CR
142 L 21339	000 580	00000 000	STATE DENTAL PLAN	0.00
142 L 21339	000 800	00000 000	STATE DENTAL PLAN	0.00
142 L 21339	000 891	00000 000	STATE DENTAL PLAN	0.00
142 L 21339	000 892	00000 000	STATE DENTAL PLAN	0.00
142 L 21339	000 900	00000 000	STATE DENTAL PLAN	381.11CR
142 L 21339	000 901	00000 000		0.00
142 L 21339	000 910	00000 000		0.00
142 L 21339	000 934	00000 000		0.00
142 L 21339	000 937	00000 000		0.00
				<hr/>
142 L 21339	---	---	-----	4,029.72CR
142 L 21340	000 000	00000 000		0.00
142 L 21340	000 010	00000 000	INSURANCE CONTRIBUTIONS	0.00
142 L 21340	000 100	00000 000	INSURANCE CONTRIBUTIONS	0.00
142 L 21340	000 160	00000 000	INSURANCE CONTRIBUTIONS	0.00
142 L 21340	000 200	00000 000	INSURANCE CONTRIBUTIONS	0.00
142 L 21340	000 440	00000 000	INSURANCE CONTRIBUTIONS	0.00
142 L 21340	000 580	00000 000	INSURANCE CONTRIBUTIONS	0.00
142 L 21340	000 800	00000 000	INSURANCE CONTRIBUTIONS	0.00
142 L 21340	000 891	00000 000	INSURANCE CONTRIBUTIONS	0.00
142 L 21340	000 892	00000 000	MEDICAL INSURANCE PAYABLE	0.00
142 L 21340	000 900	00000 000	INSURANCE CONTRIBUTIONS	0.00
142 L 21340	000 910	00000 000	INSURANCE CONTRIBUTIONS	0.00
142 L 21340	000 937	00000 000		0.00
				<hr/>
142 L 21340	---	---	-----	0.00
142 L 21342	000 010	00000 000		0.00
142 L 21342	000 100	00000 000	HARTFORD ROTH	0.00
142 L 21342	000 160	00000 000	HARTFORD ROTH	0.00
142 L 21342	000 200	00000 000	HARTFORD ROTH	0.00
142 L 21342	000 440	00000 000	HARTFORD ROTH	0.00
142 L 21342	000 900	00000 000	HARTFORD ROTH	0.00
142 L 21342	000 910	00000 000		0.00

Fnd T Acct	Obj Prj Loc	Prg	Account Level Description	Amount
L			Liability	
142 L 21342	---	---	-----	0.00
142 L 21343	000 000	00000	000	0.00
142 L 21343	000 010	00000	000 AMERICAN FAMILY LIFE	0.00
142 L 21343	000 100	00000	000 AMERICAN FAMILY LIFE	0.00
142 L 21343	000 160	00000	000 AMERICAN FAMILY LIFE	0.00
142 L 21343	000 200	00000	000 AMERICAN FAMILY LIFE	0.00
142 L 21343	000 440	00000	000 AMERICAN FAMILY LIFE	0.00
142 L 21343	000 800	00000	000 AMERICAN FAMILY LIFE	0.00
142 L 21343	000 900	00000	000 AMERICAN FAMILY LIFE	15.88
142 L 21343	000 901	00000	000	0.00
142 L 21343	000 910	00000	000 AMERICAN FAMILY LIFE	0.00
142 L 21343	000 912	00000	000	0.00
142 L 21343	000 930	00000	000	0.00
142 L 21343	000 934	00000	000	0.00
142 L 21343	000 937	00000	000	0.00
142 L 21343	000 940	00000	000	0.00
142 L 21343	---	---	-----	15.88
142 L 21344	000 100	00000	000 HORACE MANN LIFE INS	0.00
142 L 21344	000 160	00000	000 TITLE I-D	0.00
142 L 21344	000 900	00000	000 HORACE MANN LIFE INS	0.00
142 L 21344	---	---	-----	0.00
142 L 21346	000 000	00000	000	0.00
142 L 21346	000 010	00000	000 WASHINGTON NATIONAL INS	0.00
142 L 21346	000 160	00000	000 TITLE I-D	0.00
142 L 21346	000 900	00000	000 WASHINGTON NATIONAL INS	0.00
142 L 21346	000 910	00000	000 WASHINGTON NATIONAL INS	0.00
142 L 21346	---	---	-----	0.00
142 L 21347	000 000	00000	000	0.00
142 L 21347	000 100	00000	000 LIBERTY NATIONAL	0.00
142 L 21347	000 440	00000	000 LIBERTY NATIONAL	0.00
142 L 21347	000 800	00000	000 DEARBORN NATIONAL LIFE INSURAN	0.00
142 L 21347	000 900	00000	000 LIBERTY NATIONAL	0.00
142 L 21347	000 910	00000	000 LIBERTY NATIONAL	0.00
142 L 21347	---	---	-----	0.00
142 L 21348	000 000	00000	000	0.00
142 L 21348	000 010	00000	000 MEDICAL INSURANCE	0.00
142 L 21348	000 100	00000	000 MEDICAL INSURANCE	0.00
142 L 21348	000 160	00000	000 MEDICAL INSURANCE	0.00
142 L 21348	000 200	00000	000 EMPLOYEE INSURANCE DEDUCTIONS	0.00
142 L 21348	000 440	00000	000 MEDICAL INSURANCE	0.00
142 L 21348	000 580	00000	000 MEDICAL INSURANCE	0.00
142 L 21348	000 800	00000	000 MEDICAL INSURANCE	0.00
142 L 21348	000 891	00000	000 EMPLOYEE INSURANCE DEDUCTIONS	0.00
142 L 21348	000 900	00000	000 MEDICAL INSURANCE	0.00
142 L 21348	000 910	00000	000 MEDICAL INSURANCE	0.00
142 L 21348	000 937	00000	000	0.00
142 L 21348	---	---	-----	0.00
142 L 21349	000 010	00000	000	0.00
142 L 21349	000 100	00000	000 UNITED WAY	0.00

Fnd T Acct	Obj Prj Loc	Prg	Account Level Description	Amount
L			Liability	
142 L 21349	000 200 00000	000		0.00
142 L 21349	000 440 00000	000		0.00
142 L 21349	000 900 00000	000	UNITED WAY	0.00
142 L 21349	000 912 00000	000		0.00
142 L 21349	000 937 00000	000		0.00
				<hr/>
142 L 21349	---	---	-----	0.00
142 L 21351	000 010 00000	000	HORACE MANN ANNUITY	0.00
142 L 21351	000 100 00000	000	HORACE MANN ANNUITY	0.00
142 L 21351	000 160 00000	000	HORACE MANN ANNUITY	0.00
142 L 21351	000 200 00000	000	HORACE MANN ANNUITY	0.00
142 L 21351	000 440 00000	000	HORACE MANN ANNUITY	0.00
142 L 21351	000 580 00000	000	HORACE MANN ANNUITY	0.00
				<hr/>
142 L 21351	---	---	-----	0.00
142 L 21353	000 000 00000	000		0.00
142 L 21353	000 010 00000	000	DAVIS VISION	0.00
142 L 21353	000 100 00000	000	DAVIS VISION	713.76CR
142 L 21353	000 160 00000	000	DAVIS VISION	0.00
142 L 21353	000 200 00000	000	DAVIS VISION	45.30CR
142 L 21353	000 440 00000	000	DAVIS VISION	54.36CR
142 L 21353	000 580 00000	000	DAVIS VISION	0.00
142 L 21353	000 800 00000	000	DAVIS VISION	0.00
142 L 21353	000 900 00000	000	DAVIS VISION	799.25CR
142 L 21353	000 937 00000	000		0.00
				<hr/>
142 L 21353	---	---	-----	1,612.67CR
142 L 21354	000 000 00000	000	ONE AMERICA	0.00
142 L 21354	000 100 00000	000	ONE AMERICA	0.00
142 L 21354	000 160 00000	000	ONE AMERICA	0.00
142 L 21354	000 200 00000	000	ONE AMERICA	0.00
142 L 21354	000 440 00000	000	ONE AMERICA	0.00
142 L 21354	000 580 00000	000	ONE AMERICA	0.00
142 L 21354	000 800 00000	000	ONE AMERICA	0.00
142 L 21354	000 891 00000	000	ONE AMERICA	0.00
142 L 21354	000 900 00000	000	ONE AMERICA	17.46CR
142 L 21354	000 901 00000	000	ARP IDEA PART B	0.00
142 L 21354	000 910 00000	000	ONE AMERICA	0.00
142 L 21354	000 937 00000	000		0.00
				<hr/>
142 L 21354	---	---	-----	17.46CR
142 L 21356	000 100 00000	000	TRUSTMARK	0.00
142 L 21356	000 160 00000	000	TRUSTMARK	0.00
142 L 21356	000 200 00000	000	TRUSTMARK	0.00
142 L 21356	000 900 00000	000	TRUSTMARK	15.92CR
				<hr/>
142 L 21356	---	---	-----	15.92CR
142 L 21357	000 100 00000	000	MODERN WOODMEN INS PAYABL	0.00
				<hr/>
142 L 21357	---	---	-----	0.00
142 L 21358	000 100 00000	000	HYBRID TAXED CONTRIBUTION	0.00
142 L 21358	000 890 00000	000		0.00
142 L 21358	000 896 00000	000	HYBRID TAXED CONTRIBUTION	30.00
142 L 21358	000 898 00000	000		0.00
142 L 21358	000 934 00000	000	HYBRID TAXED CONTRIBUTION	0.00

Fnd T Acct	Obj Prj Loc	Prg	Account Level Description	Amount
L			Liability	
142 L 21358 000 935 00000 000			HYBRID TAXED CONTRIBUTION	0.00
142 L 21358 000 937 00000 000			HYBRID TAXED CONTRIBUTION	0.00
142 L 21358 --- --- ----- ---				30.00
142 L 21359 000 000 00000 000			HYBRID PRETAXED CONTRIBUTION	0.00
142 L 21359 000 010 00000 000				0.00
142 L 21359 000 100 00000 000			HYBRID PRETAXED CONTRIBUTION	199.20
142 L 21359 000 200 00000 000			HYBRID PRETAXED CONTRIBUTION	0.00
142 L 21359 000 440 00000 000			HYBRID PRETAXED CONTRIBUTION	0.00
142 L 21359 000 720 00000 000				0.00
142 L 21359 000 890 00000 000				0.00
142 L 21359 000 891 00000 000			HYBRID PRETAXED CONTRIBUTION	0.00
142 L 21359 000 896 00000 000				61.95
142 L 21359 000 898 00000 000				0.00
142 L 21359 000 900 00000 000			HYBRID PRETAXED CONTRIBUTION	1,410.75
142 L 21359 000 901 00000 000				0.00
142 L 21359 000 930 00000 000				0.00
142 L 21359 000 931 00000 000				0.00
142 L 21359 000 934 00000 000				0.00
142 L 21359 000 935 00000 000				0.00
142 L 21359 000 937 00000 000				0.00
142 L 21359 000 938 00000 000				0.00
142 L 21359 000 940 00000 000				0.00
142 L 21359 --- --- ----- ---				1,671.90
142 L 21360 000 100 00000 000			GARNISHMENTS AND LEVIES	3,272.64CR
142 L 21360 000 900 00000 000			GARNISHMENTS AND LEVIES	373.70
142 L 21360 000 934 00000 000				0.00
142 L 21360 000 935 00000 000				0.00
142 L 21360 --- --- ----- ---				2,898.94CR
142 L 21362 000 000 00000 000				0.00
142 L 21362 000 100 00000 000			USABLE LIFE INS	0.00
142 L 21362 000 200 00000 000			USABLE LIFE INS	0.00
142 L 21362 000 580 00000 000			USABLE LIFE INS	0.00
142 L 21362 000 800 00000 000			USABLE Life	0.00
142 L 21362 000 900 00000 000			USABLE LIFE INS	0.00
142 L 21362 000 910 00000 000			USABLE LIFE INS	0.00
142 L 21362 201 000 00000 000				0.00
142 L 21362 201 100 00000 000			SOCIAL SECURITY	0.00
142 L 21362 201 200 00000 000			SOCIAL SECURITY	0.00
142 L 21362 201 900 00000 000			SOCIAL SECURITY	0.00
142 L 21362 201 910 00000 000			SOCIAL SECURITY	0.00
142 L 21362 204 000 00000 000				0.00
142 L 21362 204 100 00000 000			STATE RETIREMENT	0.00
142 L 21362 204 200 00000 000			STATE RETIREMENT	0.00
142 L 21362 204 900 00000 000			STATE RETIREMENT	0.00
142 L 21362 204 910 00000 000			STATE RETIREMENT	0.00
142 L 21362 207 000 00000 000				0.00
142 L 21362 207 100 00000 000			MEDICAL INSURANCE	0.00
142 L 21362 207 160 00000 000			MEDICAL INSURANCE	0.00
142 L 21362 207 200 00000 000			MEDICAL INSURANCE	0.00
142 L 21362 207 900 00000 000			MEDICAL INSURANCE	0.00
142 L 21362 207 910 00000 000			MEDICAL INSURANCE	0.00
142 L 21362 212 000 00000 000				0.00

Fnd T Acct	Obj Prj Loc	Prg	Account Level Description	Amount
L			Liability	
142 L 21362	212 100	00000 000	MEDICARE	0.00
142 L 21362	212 200	00000 000	MEDICARE	0.00
142 L 21362	212 900	00000 000	MEDICARE	0.00
142 L 21362	212 910	00000 000	MEDICARE	0.00
142 L 21362	---	---	-----	0.00
142 L 21365	000 010	00000 000		0.00
142 L 21365	000 100	00000 000	WAGWORKS	0.00
142 L 21365	000 200	00000 000	WAGWORKS	0.00
142 L 21365	000 580	00000 000	WAGWORKS	0.00
142 L 21365	000 900	00000 000	WAGWORKS	0.00
142 L 21365	000 912	00000 000		0.00
142 L 21365	---	---	-----	0.00
142 L 21366	000 100	00000 000		0.00
142 L 21366	000 200	00000 000		0.00
142 L 21366	000 900	00000 000	LSW/VALUE TEACH	0.00
142 L 21366	000 937	00000 000		0.00
142 L 21366	---	---	-----	0.00
142 L 21370	000 010	00000 000	AIG RETIREMENT (VALIC)	0.00
142 L 21370	000 100	00000 000	AIG RETIREMENT (VALIC)	0.00
142 L 21370	000 200	00000 000	AIG RETIREMENT (VALIC)	0.00
142 L 21370	000 440	00000 000	AIG RETIREMENT (VALIC)	0.00
142 L 21370	---	---	-----	0.00
142 L 21380	000 010	00000 000	CREDIT UNION DEDUCTION	0.00
142 L 21380	000 100	00000 000	CREDIT UNION DEDUCTION	0.00
142 L 21380	000 580	00000 000	CREDIT UNION DEDUCTION	0.00
142 L 21380	---	---	-----	0.00
142 L 21390	000 010	00000 000	NEA TEA WCEA DUES	0.00
142 L 21390	000 100	00000 000	NEA TEA WCEA DUES	0.00
142 L 21390	000 200	00000 000	NEA TEA WCEA DUES	0.00
142 L 21390	000 580	00000 000	NEA TEA WCEA DUES	0.00
142 L 21390	000 900	00000 000	NEA TEA WCEA DUES	0.00
142 L 21390	---	---	-----	0.00
142 L 21392	000 900	00000 000		0.00
142 L 21392	---	---	-----	0.00
142 L 21500	000 000	00000 000		0.00
142 L 21500	000 010	00000 000	DUE TO OTHER FUNDS	0.00
142 L 21500	000 100	00000 000	DUE TO OTHER FUNDS	0.00
142 L 21500	000 160	00000 000	DUE TO OTHER FUNDS	0.00
142 L 21500	000 200	00000 000	DUE TO OTHER FUNDS	0.00
142 L 21500	000 300	00000 000	DUE TO OTHER FUNDS	0.00
142 L 21500	000 440	00000 000	DUE TO OTHER FUNDS	0.00
142 L 21500	000 720	00000 000	DUE TO OTHER FUNDS	0.00
142 L 21500	000 800	00000 000	DUE TO OTHER FUNDS	0.00
142 L 21500	000 891	00000 000	DUE TO OTHER FUNDS	0.00
142 L 21500	000 892	00000 000	DUE TO OTHER FUNDS	0.00
142 L 21500	000 894	00000 000	DUE TO OTHER FUNDS	0.00
142 L 21500	000 896	00000 000	Due To Other Funds	0.00
142 L 21500	000 900	00000 000	DUE TO OTHER FUNDS	0.00

Fnd T Acct	Obj Prj Loc	Prg	Account Level Description	Amount
L			Liability	
142 L 21500 000 901 00000 000			DUE TO OTHER FUNDS	0.00
142 L 21500 000 910 00000 000			DUE TO OTHER FUNDS	0.00
142 L 21500 000 934 00000 000			DUE TO OTHER FUNDS	0.00
142 L 21500 000 935 00000 000			DUE TO OTHER FUNDS	0.00
142 L 21500 000 938 00000 000			BEST FOR ALL DISTRICT GRANT	0.00
142 L 21500 000 940 00000 000			Due To Other Funds	0.00
142 L 21500 --- --- ----- ---				0.00
142 L 21530 000 000 00000 000			DUE TO STATE OF TENNESSEE	0.00
142 L 21530 000 010 00000 000			DUE TO STATE OF TENNESSEE	0.00
142 L 21530 000 200 00000 000			DUE TO STATE OF TENNESSEE	0.00
142 L 21530 000 800 00000 000			DUE TO STATE OF TN	0.00
142 L 21530 000 892 00000 000			Due to State of Tennessee	0.00
142 L 21530 000 900 00000 000			DUE TO STATE OF TENNESSEE	0.00
142 L 21530 --- --- ----- ---				0.00
142 L 21535 000 100 00000 000			DAVIS VISION	0.00
142 L 21535 --- --- ----- ---				0.00
142 L 21900 000 000 00000 000				0.00
142 L 21900 000 010 00000 000			OTHER CURRENT LIABILITIES	0.00
142 L 21900 000 100 00000 000			OTHER CURRENT LIABILITIES	0.00
142 L 21900 000 160 00000 000			OTHER CURRENT LIABILITIES	0.00
142 L 21900 000 200 00000 000			OTHER CURRENT LIABILITIES	0.00
142 L 21900 000 440 00000 000			OTHER CURRENT LIABILITIES	0.00
142 L 21900 000 720 00000 000				0.00
142 L 21900 000 800 00000 000			OTHER CURRENT LIABILITIES	0.00
142 L 21900 000 890 00000 000				0.00
142 L 21900 000 891 00000 000			OTHER CURRENT LIABILITIES	0.00
142 L 21900 000 894 00000 000			OTHER CURRENT LIABILITIES	0.00
142 L 21900 000 895 00000 000			OTHER CURRENT LIABILITIES	0.00
142 L 21900 000 896 00000 000			OTHER CURRENT LIABILITIES	0.00
142 L 21900 000 898 00000 000				0.00
142 L 21900 000 900 00000 000			OTHER CURRENT LIABILITIES	0.00
142 L 21900 000 901 00000 000				0.00
142 L 21900 000 910 00000 000			OTHER CURRENT LIABILITIES	0.00
142 L 21900 000 912 00000 000				0.00
142 L 21900 000 930 00000 000				0.00
142 L 21900 000 931 00000 000				0.00
142 L 21900 000 934 00000 000				0.00
142 L 21900 000 935 00000 000				0.00
142 L 21900 000 937 00000 000				0.00
142 L 21900 000 938 00000 000				0.00
142 L 21900 000 940 00000 000				0.00
142 L 21900 000 950 00000 000				0.00
142 L 21900 --- --- ----- ---				0.00
142 L ----- --- --- ----- ---				52,316.44

=====

Fnd T	Acct	Obj	Prj	Loc	Prg	Account Level Description	Amount
Q						Equity	
142	Q	34100	000	800	00000	000 PO PAYABLE	0.00
142	Q	34100	---	---	-----	---	0.00
142	Q	34110	000	000	00000	000 PURCHASE ORDER PAYABLE	0.00
142	Q	34110	000	100	00000	000 PURCHASE ORDER PAYABLE	0.00
142	Q	34110	000	160	00000	000 PURCHASE ORDER PAYABLE	0.00
142	Q	34110	000	200	00000	000 PURCHASE ORDER PAYABLE	0.00
142	Q	34110	000	440	00000	000 PURCHASE ORDER PAYABLE	0.00
142	Q	34110	000	800	00000	000 PURCHASE ORDER PAYABLE	0.00
142	Q	34110	000	891	00000	000 PURCHASE ORDER PAYABLE	0.00
142	Q	34110	000	892	00000	000 PURCHASE ORDER PAYABLE	0.00
142	Q	34110	000	893	00000	000 PURCHASE ORDER PAYABLE	0.00
142	Q	34110	---	---	-----	---	0.00
142	Q	34111	000	000	00000	000	0.00
142	Q	34111	---	---	-----	---	0.00
142	Q	34120	000	000	00000	000	0.00
142	Q	34120	---	---	-----	---	0.00
142	Q	34555	000	010	00000	000 RESTRICTED FOR ED.-CARRY FORW	0.00
142	Q	34555	000	100	00000	000 RESTRICTED FOR ED.-CARRY FORW	0.00
142	Q	34555	000	901	00000	000 RESTRICTED FOR ED.-CARRY FORW	0.00
142	Q	34555	000	937	00000	000 RESTRICTED FOR ED.-CARRY FORW	0.00
142	Q	34555	---	---	-----	---	0.00
142	Q	39000	000	000	00000	000	1,492,570.48CR
142	Q	39000	000	010	00000	000 REV EXP SUMMARY FLOW THROUGH	8,522.14
142	Q	39000	000	100	00000	000 REV EXP SUMMARY FLOW THROUGH	129,535.02
142	Q	39000	000	101	00000	000	0.00
142	Q	39000	000	160	00000	000 REV EXP SUMMARY FLOW THROUGH	719.98
142	Q	39000	000	171	00000	000	0.00
142	Q	39000	000	172	00000	000	0.00
142	Q	39000	000	200	00000	000 REV EXP SUMMARY FLOW THROUGH	7,594.27
142	Q	39000	000	440	00000	000 REV EXP SUMMARY FLOW THROUGH	7,220.19
142	Q	39000	000	700	00000	000	0.00
142	Q	39000	000	705	00000	000	0.00
142	Q	39000	000	720	00000	000	0.00
142	Q	39000	000	800	00000	000 REV EXP SUMMARY FLOW THROUGH	35,398.89
142	Q	39000	000	801	00000	000 REV EXP SUMMARY FLOW THROUGH	0.00
142	Q	39000	000	802	00000	000	0.00
142	Q	39000	000	803	00000	000	0.00
142	Q	39000	000	890	00000	000	0.00
142	Q	39000	000	891	00000	000 REV EXP SUMMARY FLOW THROUGH	0.00
142	Q	39000	000	892	00000	000 REV EXP SUMMARY FLOW THROUGH	0.00
142	Q	39000	000	893	00000	000 REV EXP SUMMARY FLOW THROUGH	0.00
142	Q	39000	000	894	00000	000 REV EXP SUMMARY FLOW THROUGH	0.00
142	Q	39000	000	895	00000	000 REV EXP SUMMARY FLOW THROUGH	0.00
142	Q	39000	000	896	00000	000 REV EXP SUMMARY FLOW THROUGH	48,928.69
142	Q	39000	000	897	00000	000	0.00
142	Q	39000	000	898	00000	000	6,365.66
142	Q	39000	000	899	00000	000	0.00
142	Q	39000	000	900	00000	000 REV EXP SUMMARY FLOW THROUGH	211,173.63
142	Q	39000	000	901	00000	000	0.00
142	Q	39000	000	910	00000	000 REV EXP SUMMARY FLOW THROUGH	17,784.35

Account Level						Amount		
Fnd	T	Acct	Obj	Prj	Loc	Prg	Description	
Q							Equity	
142	Q	39000	000	911	00000	000		0.00
142	Q	39000	000	912	00000	000		0.00
142	Q	39000	000	930	00000	000		0.00
142	Q	39000	000	931	00000	000		0.00
142	Q	39000	000	932	00000	000		0.00
142	Q	39000	000	933	00000	000		0.00
142	Q	39000	000	934	00000	000		0.00
142	Q	39000	000	935	00000	000		0.00
142	Q	39000	000	936	00000	000		0.00
142	Q	39000	000	937	00000	000		0.00
142	Q	39000	000	938	00000	000		0.00
142	Q	39000	000	939	00000	000		0.00
142	Q	39000	000	940	00000	000		0.00
142	Q	39000	000	941	00000	000		0.00
142	Q	39000	000	950	00000	000		0.00
142	Q	39000	000	951	00000	000		0.00
142	Q	39000	000	952	00000	000		0.00
142	Q	39000	000	953	00000	000		0.00
142	Q	39000	---	---	-----	---		1,019,327.66CR
142	Q	-----	---	---	-----	---		1,019,327.66CR
								=====

Grand Asset Totals	967,011.22
Grand Liability Totals	52,316.44
Grand Equity Totals	1,019,327.66CR
Grand Totals	0.00

Number of Accounts: 624

***** End of report *****

Revenue Comparison

	July	August	September	October	November	December	January	February	March	April	May	June	Totals: February 2026
FY21	180,856	132,382	4,635	279,041	290,918	265,988	316,656	273,936	253,342	383,828	476,272	261,460	1,744,422
FY22	188	238,599	43,480	465,326	869,463	545,619	349,424	478,400	550,353	730,850	573,429	468,239	2,990,493
FY23	136,432	10,497	364,883	395,361	288,979	140,146	488,978	430,937	384,305	577,919	273,278	569,779	2,256,164
FY24	83,381	50,435	398,486	393,670	120,676	679,644	249,387	427,574	390,999	332,640	102,548	636,013	2,403,264
FY25	125,697	95,284	395,316	426,278	55,690	340,045	673,804	383,664	440,849	72,358	841,012	12,550	2,485,777
FY26	542,935	122,389	498,979	552,552	347,214	495,908	414,694	367,291					3,341,962

Net Change PY

417,238

27,105

103,662

126,274

291,525

155,863

(259,110)

(16,373)

846,185

34%

Dietary Revenue Trends FY23 Through FY26

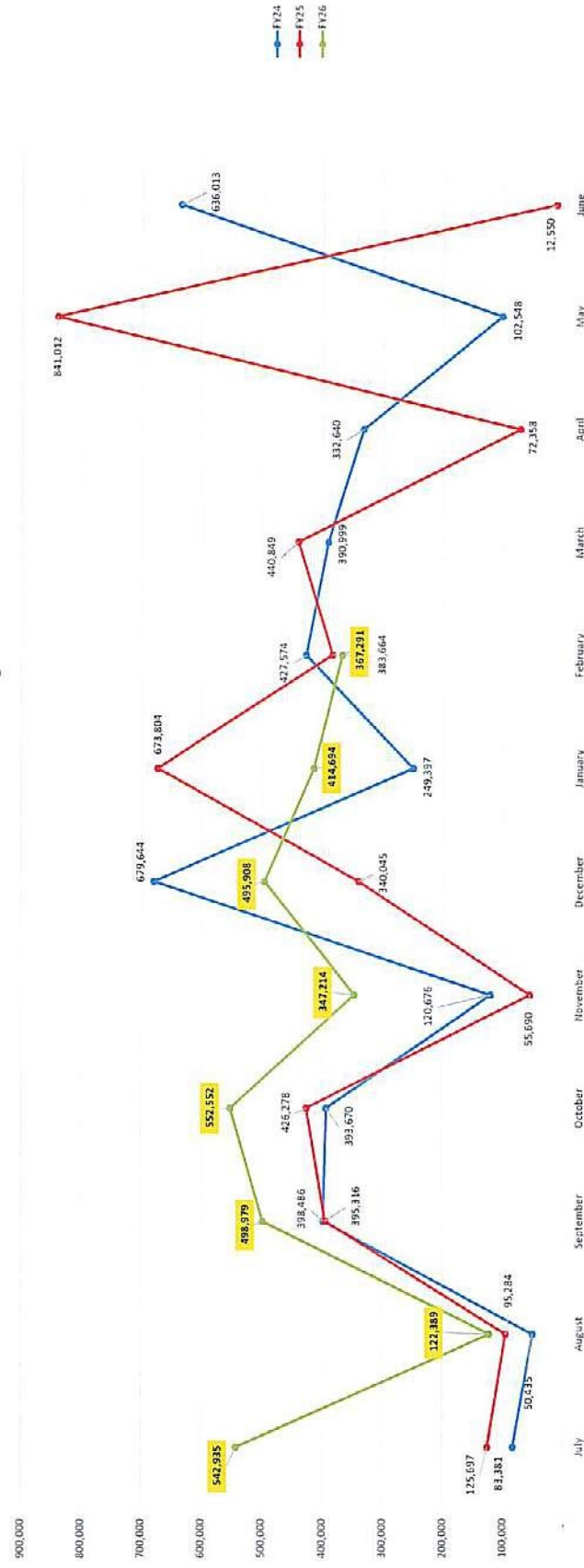

Expense Comparison

	July	August	September	October	November	December	January	February	March	April	May	June	Totals-February 2026
FY21	93,828	112,838	241,872	266,192	231,469	252,797	179,196	284,385	296,002	269,623	305,248	192,600	1,662,577
FY22	131,701	354,264	364,824	275,956	485,607	331,587	279,428	335,685	441,659	282,188	495,212	211,252	2,559,052
FY23	130,898	352,573	290,302	293,387	312,070	384,000	303,999	350,201	288,185	345,025	314,684	149,842	2,417,431
FY24	298,032	550,715	571,092	350,354	396,954	352,046	388,307	388,385	309,169	732,206	464,462	153,425	3,295,884
FY25	131,922	511,480	482,162	420,208	510,728	500,743	311,983	452,284	421,496	544,871	433,149	156,289	3,321,511
FY26	159,175	450,361	608,745	371,402	531,187	550,781	298,752	370,981					3,341,386

Net Change PY 27,253 (61,119) 126,583 (48,806) 20,459 50,038 (13,230) (81,303)

PY% Change 19,875 1%

Dietary Expense Trends FY23 through FY26

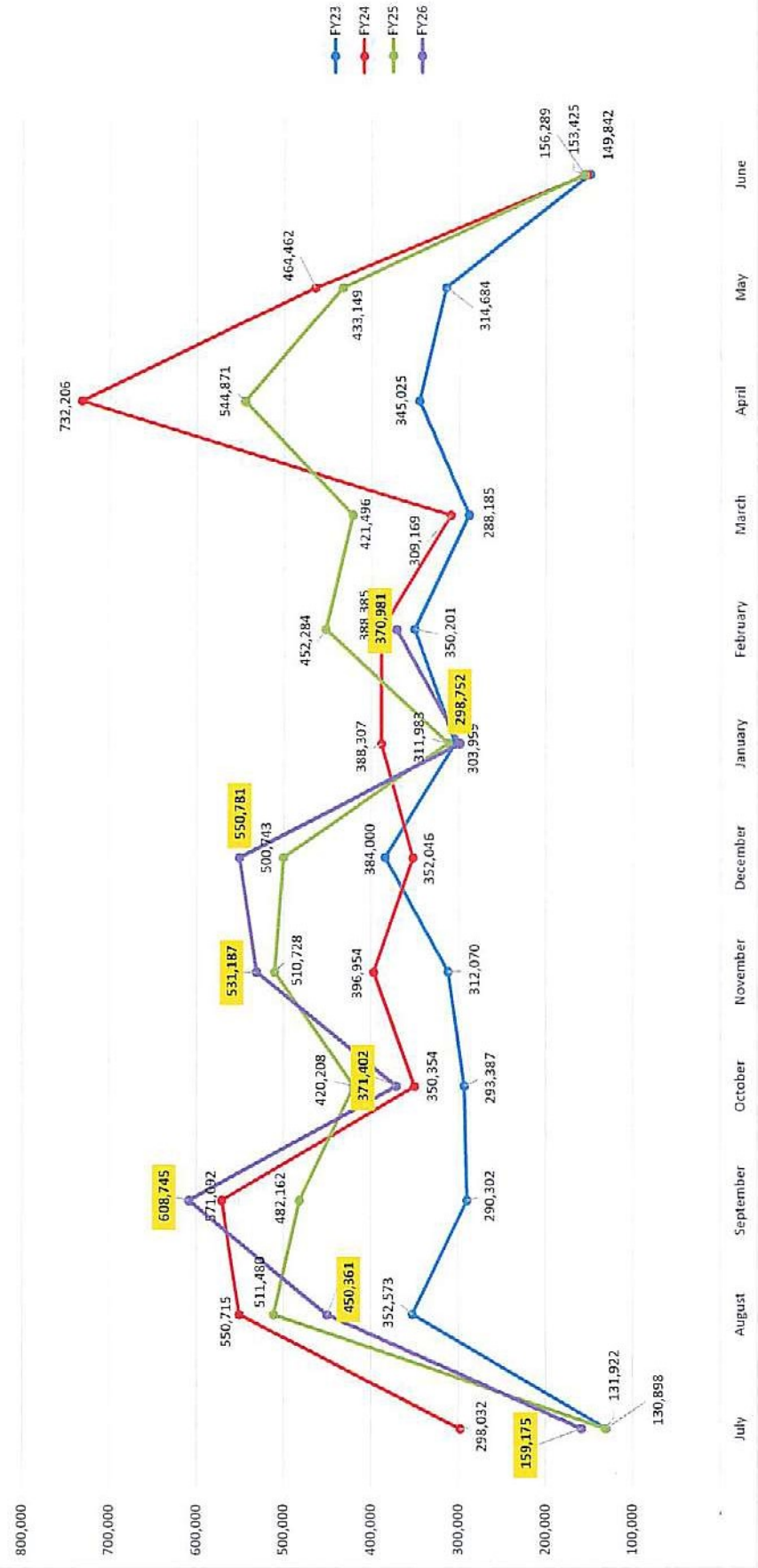

Unreconciled Dietary Fund Balance Tracking

	July	August	September	October	November	December	January	February	March	April	May	June
FY17	6,202	(380)	87,719	(66,933)	(96,404)	(260,230)	(170,632)	(67,070)	(94,864)	(76,733)	(74,830)	84,303
FY18	81,487	10,761	28,355	23,814	82,977	36,830	147,998	48,470	185,611	215,506	186,942	312,172
FY19	311,869	220,005	227,069	112,592	210,288	207,552	396,827	448,818	501,337	620,464	695,028	770,132
FY20	816,142	703,889	732,436	562,564	856,627	839,293	953,189	976,954	945,748	723,166	1,157,314	1,392,339
FY21	1,479,368	1,498,922	1,261,684	1,274,533	1,333,983	1,347,174	1,484,634	1,474,184	1,431,524	1,545,728	1,716,753	1,785,613
FY22	1,654,099	1,538,429	1,217,086	1,406,456	1,790,311	2,004,343	2,074,339	2,217,053	2,325,747	2,774,409	2,852,626	3,109,613
FY23	3,115,147	2,773,071	2,847,653	2,949,627	2,926,536	2,682,682	2,867,611	2,948,347	3,044,466	3,277,362	3,235,955	3,655,892
FY24	3,441,240	2,940,960	2,768,355	2,811,671	2,535,393	2,862,991	2,724,081	2,763,271	2,845,102	2,774,409	2,445,535	2,083,622
FY25	2,560,002	2,143,807	2,056,961	2,063,031	1,607,992	1,447,293	1,809,115	1,740,494	1,759,846	1,287,333	1,695,197	1,551,457
FY26	1,935,217	1,607,245	1,497,479	1,494,556	1,439,782	1,439,782	1,555,724	1,552,033	1,759,846	1,287,333	1,695,197	1,551,457
Variance From PY	(524,785)	(536,562)	(559,482)	(384,402)	(113,336)	(7,511)	(253,391)	(188,460)				
Variance From PM	383,760	(327,972)	(109,766)	181,149	(183,973)	(54,873)	115,941	(3,690)				

Dietary Fund Balance Tracking FY22 to FY26 (Trustee's Report)

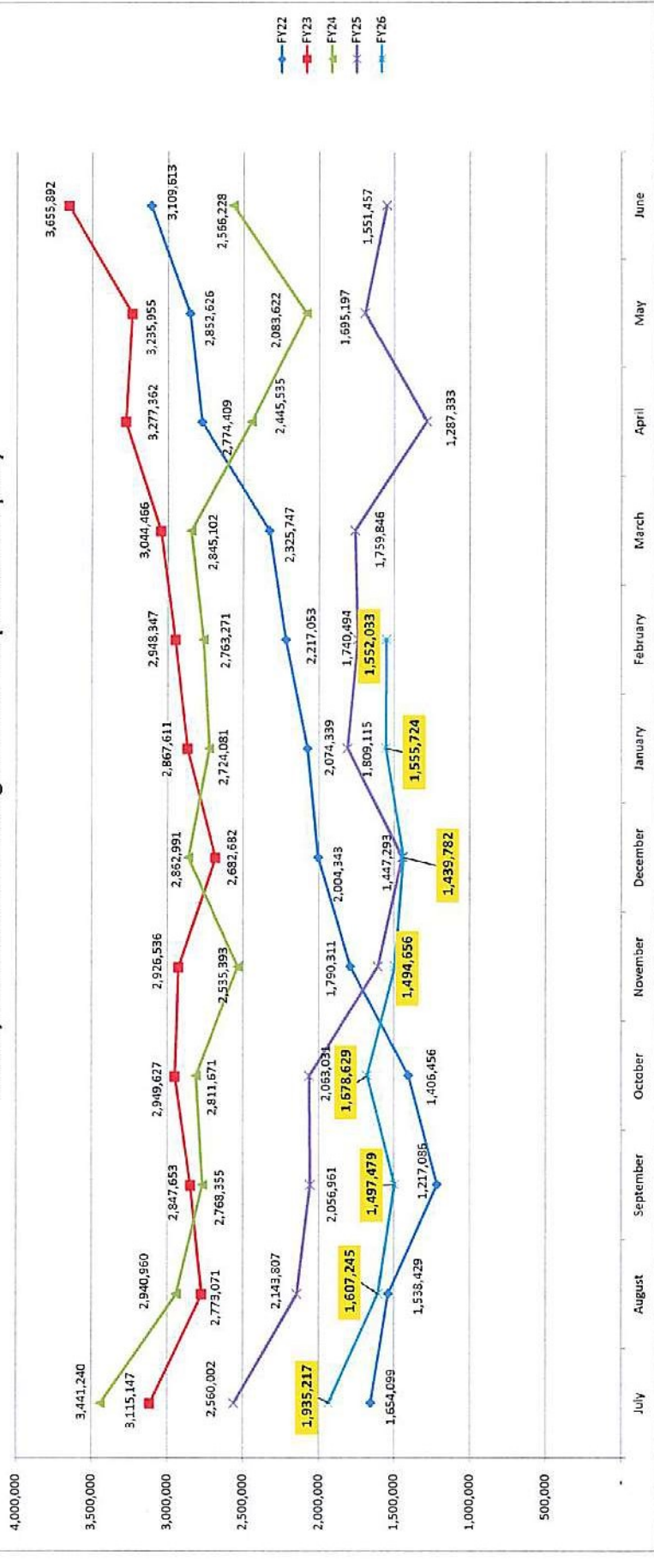

DBHS Chart of Accounts
L-Accounts are Restricted Accounts
3/23/2026

Account Number					Beginning Balance	Debit Amount	Credit Amount	Ending Balance	Account Level Description	
Fnd	T Acct	Obj	Prj	Loc	Prg					
145	A 00000	000	000	15000	100	\$ 746,069.63	\$ 568,438.99	\$ 466,475.47	\$ 848,033.15	CASH IN BANK - CHECKING

Account Number					Beginning Balance	Debit Amount	Credit Amount	Ending Balance	Account Level Description	
Fnd	T Acct	Obj	Prj	Loc	Prg					
145	L 00000	000	000	15000	800	\$ (97.75)	\$ -	\$ -	\$ (97.75)	ACADEMIC TEAM
145	L 00000	000	000	15000	200	\$ 0.33	\$ -	\$ -	\$ 0.33	ACCOUNTS PAYABLE
145	L 00000	000	000	15000	900	\$ (191.44)	\$ 710.17	\$ 2,217.24	\$ (1,698.51)	ADMINISTRATIVE
145	L 00000	000	000	15000	803	\$ (10,344.03)	\$ -	\$ 4,800.00	\$ (15,144.03)	ART
145	L 00000	000	000	15000	616	\$ (110.00)	\$ -	\$ -	\$ (110.00)	ATHLETIC EQUIPMENT
145	L 00000	000	000	15000	602	\$ -	\$ -	\$ -	\$ -	ATHLETIC RESERVE
145	L 00000	000	000	15000	620	\$ (2,222.78)	\$ 12,913.94	\$ 12,675.58	\$ (1,984.42)	ATHLETICS - MIDDLE SCHOOL
145	L 00000	000	000	15000	601	\$ -	\$ -	\$ -	\$ -	ATHLETICS - OTHER
145	L 00000	000	000	15000	617	\$ (3,946.66)	\$ 1,098.00	\$ 14,300.00	\$ (17,148.66)	ATHLETICS - SP/RESERVE
145	L 00000	000	000	15000	614	\$ (3,835.52)	\$ 4,277.52	\$ 2,717.52	\$ (2,275.52)	ATHLETICS - TRAINING ROOM
145	L 00000	000	000	15000	615	\$ (720.35)	\$ -	\$ -	\$ (720.35)	ATHLETICS - WEIGHT ROOM
145	L 00000	000	000	15000	600	\$ (17,944.29)	\$ 177,613.47	\$ 180,311.16	\$ (20,641.98)	ATHLETICS-GENERAL
145	L 00000	000	000	15000	914	\$ -	\$ 3,161.27	\$ 9,000.00	\$ (5,838.73)	BAND
145	L 00000	000	000	15000	604	\$ (7,955.29)	\$ 10,711.95	\$ 25,063.22	\$ (22,306.56)	BASEBALL
145	L 00000	001	000	15000	605	\$ (3,861.79)	\$ 25,124.24	\$ 39,845.84	\$ (18,583.39)	BASKETBALL - BOYS
145	L 00000	002	000	15000	605	\$ (7,355.58)	\$ 16,632.86	\$ 21,911.28	\$ (12,634.00)	BASKETBALL - GIRLS
145	L 00000	000	000	15000	807	\$ (438.35)	\$ 95.10	\$ 3,328.00	\$ (3,671.25)	BETA CLUB
145	L 00000	001	000	15000	915	\$ -	\$ -	\$ -	\$ -	BIOLOGY
145	L 00000	001	000	15000	916	\$ (64.45)	\$ -	\$ -	\$ (64.45)	BIOLOGY - BARR
145	L 00000	000	000	15000	734	\$ (116.25)	\$ -	\$ -	\$ (116.25)	BIOLOGY - CARR
145	L 00000	001	000	15000	917	\$ (923.47)	\$ -	\$ -	\$ (923.47)	BIOLOGY - FEATHERS
145	L 00000	002	000	15000	916	\$ -	\$ -	\$ -	\$ -	BIOLOGY - KIERNAN
145	L 00000	000	000	15000	735	\$ (482.07)	\$ 93.74	\$ 15.00	\$ (403.33)	BIOLOGY - KRTAUSCH
145	L 00000	000	000	15000	603	\$ (12,089.58)	\$ 31,352.99	\$ 34,898.88	\$ (15,635.47)	BLAZER ATHLETIC SUPPORT
145	L 00000	000	000	15000	970	\$ (136.64)	\$ -	\$ -	\$ (136.64)	BOARD ALLOCATION - ATTENDANCE
145	L 00000	000	000	15000	971	\$ -	\$ -	\$ -	\$ -	BOARD ALLOCATION - COPIER
145	L 00000	000	000	15000	972	\$ (3.00)	\$ -	\$ -	\$ (3.00)	BOARD ALLOCATION - MATERIALS
145	L 00000	000	000	15000	919	\$ (2,054.36)	\$ 126.00	\$ -	\$ (1,928.36)	BUILDING TRADES
145	L 00000	000	000	15000	606	\$ (9,953.03)	\$ 9,352.79	\$ 7,224.60	\$ (7,824.84)	CHEERLEADING
145	L 00000	001	000	15000	921	\$ (29.67)	\$ -	\$ -	\$ (29.67)	CHEMISTRY - CARR
145	L 00000	002	000	15000	921	\$ (236.60)	\$ -	\$ -	\$ (236.60)	CHEMISTRY - CARR
145	L 00000	000	000	15000	733	\$ (14.76)	\$ -	\$ -	\$ (14.76)	CHEMISTRY - KELLEY
145	L 00000	000	000	15000	825	\$ (1,173.00)	\$ -	\$ -	\$ (1,173.00)	CHIC FIL A ACADEMY
145	L 00000	000	000	15000	923	\$ (17,222.65)	\$ 13,910.44	\$ 10,107.00	\$ (13,419.21)	CHORUS
145	L 00000	000	000	15000	924	\$ (2,019.31)	\$ 10,623.95	\$ 14,065.00	\$ (5,460.36)	CIVIL WAR HISTORY
145	L 00000	000	000	15000	716	\$ (2,530.26)	\$ 1,836.41	\$ 1,914.00	\$ (2,607.85)	CLASS OF 2026
145	L 00000	000	000	15000	721	\$ (225.00)	\$ 225.00	\$ -	\$ -	CLASS OF 2027
145	L 00000	000	000	15000	736	\$ (444.83)	\$ -	\$ -	\$ (444.83)	COMMUNICATIONS TECHNOLOGY
145	L 00000	000	000	15000	928	\$ (1,058.00)	\$ 50.00	\$ 265.00	\$ (1,273.00)	COSMETOLOGY
145	L 00000	000	000	15000	619	\$ (1,241.53)	\$ 600.00	\$ 1,570.00	\$ (2,211.53)	CROSS COUNTRY & TRACK
145	L 00000	000	000	15000	840	\$ (482.49)	\$ 1,845.60	\$ 3,159.50	\$ (1,796.39)	DANCE TEAM
145	L 00000	000	000	15000	940	\$ -	\$ -	\$ -	\$ -	DIGITAL ARTS
145	L 00000	000	000	15000	929	\$ (12.93)	\$ -	\$ -	\$ (12.93)	DIVERSIFIED TECHNOLOGY
145	L 00000	000	000	15000	930	\$ (1,293.82)	\$ -	\$ 49.00	\$ (1,342.82)	DRAFTING
145	L 00000	000	000	15000	814	\$ (1,378.16)	\$ 1,718.50	\$ 4,042.00	\$ (3,701.66)	DRAMA -PLAYWRITING
145	L 00000	000	000	15000	931	\$ -	\$ -	\$ -	\$ -	DRIVERS EDUCATION
145	L 00000	000	000	15000	932	\$ (563.53)	\$ -	\$ -	\$ (563.53)	ECOLOGY
145	L 00000	000	000	15000	801	\$ (507.46)	\$ 476.00	\$ 150.00	\$ (181.46)	EDUCATORS RISING
145	L 00000	000	000	15000	933	\$ (358.71)	\$ 226.00	\$ -	\$ (132.71)	ELECTRICITY
145	L 00000	000	000	15000	710	\$ (691.39)	\$ -	\$ -	\$ (691.39)	ENGLISH
145	L 00000	000	000	15000	709	\$ (90.00)	\$ -	\$ -	\$ (90.00)	ENGLISH -CLARK
145	L 00000	000	000	15000	934	\$ (349.72)	\$ -	\$ -	\$ (349.72)	ENGLISH-709
145	L 00000	000	000	15000	737	\$ (148.36)	\$ -	\$ -	\$ (148.36)	ENVIRONMENTAL SCIENCE
145	L 00000	000	000	15000	969	\$ -	\$ -	\$ -	\$ -	EPIC
145	L 00000	000	000	15000	908	\$ (211.49)	\$ -	\$ -	\$ (211.49)	EPSO Grant
145	L 00000	000	000	15000	958	\$ (143.10)	\$ 268.79	\$ 161.30	\$ (35.61)	FACULTY FUND
145	L 00000	000	000	15000	935	\$ (79.10)	\$ 4,173.63	\$ 4,173.63	\$ (79.10)	FAMILY AND CONSUMER SCIENCE
145	L 00000	000	000	15000	936	\$ (645.62)	\$ -	\$ -	\$ (645.62)	FARM ACCOUNT/SHOW TEAMS
145	L 00000	000	000	15000	817	\$ (927.15)	\$ -	\$ 600.00	\$ (1,527.15)	FCA
145	L 00000	000	000	15000	720	\$ (1,125.88)	\$ -	\$ -	\$ (1,125.88)	FCCLA II - SERVICE PROJECTS
145	L 00000	000	000	15000	819	\$ (11,508.00)	\$ 10,278.47	\$ 9,749.03	\$ (10,978.56)	FFA
145	L 00000	000	000	15000	821	\$ (205.40)	\$ -	\$ -	\$ (205.40)	FISHING CLUB
145	L 00000	000	000	15000	607	\$ (566.50)	\$ -	\$ -	\$ (566.50)	FOOTBALL
145	L 00000	000	000	15000	822	\$ (201.00)	\$ 78.55	\$ -	\$ (122.45)	FRENCH CLUB
145	L 00000	000	000	15000	939	\$ (90.73)	\$ -	\$ -	\$ (90.73)	GEOLOGY

145 L 00000 000 000 15000 621	\$ (3,701.94)	\$	5,095.83	\$	5,445.51	\$ (4,051.62)	GIRLS SOCCER
145 L 00000 000 000 15000 818	\$ (590.38)	\$	-	\$	-	\$ (590.38)	GO-CART
145 L 00000 000 000 15000 608	\$ (12,909.53)	\$	12,121.64	\$	16,380.00	\$ (17,167.89)	GOLF
145 L 00000 000 000 15000 907	\$ (1.00)	\$	-	\$	-	\$ (1.00)	GRAD GIVES
145 L 00000 000 000 15000 906	\$ (12,200.46)	\$	802.80	\$	1,500.00	\$ (12,897.66)	GUIDANCE
145 L 00000 000 000 15000 943	\$ (19,500.38)	\$	2,954.07	\$	-	\$ (16,546.31)	HORTICULTURE
145 L 00000 000 000 15000 712	\$ (900.00)	\$	170.00	\$	100.00	\$ (830.00)	HOSA- HANNAH'S GRACE
145 L 00000 000 000 15000 826	\$ (1,840.50)	\$	6,754.20	\$	16,596.62	\$ (11,682.92)	HOSA II
145 L 00000 000 000 15000 920	\$ (40.00)	\$	-	\$	500.00	\$ (540.00)	HVAC
145 L 00000 000 000 15000 944	\$ -	\$	-	\$	-	\$ -	INFORMATION TECHNOLOGY
145 L 00000 000 000 15000 827	\$ (1,552.75)	\$	-	\$	-	\$ (1,552.75)	INTERNATIONAL CLUB
145 L 00000 001 000 15000 946	\$ (108,304.25)	\$	13,667.63	\$	60,000.77	\$ (154,637.39)	JROTC - MISCELLANEOUS
145 L 00000 002 000 15000 946	\$ -	\$	-	\$	-	\$ -	JROTC - OFFICERS
145 L 00000 005 000 15000 903	\$ (48.82)	\$	-	\$	-	\$ (48.82)	JROTC GRANT
145 L 00000 000 000 15000 828	\$ (537.38)	\$	3,854.85	\$	3,551.75	\$ (234.28)	KEY CLUB
145 L 00000 000 000 15000 948	\$ (2,021.33)	\$	-	\$	-	\$ (2,021.33)	KEYBOARDING
145 L 00000 000 000 15000 962	\$ (336.86)	\$	-	\$	-	\$ (336.86)	LIBRARY
145 L 00000 000 000 15000 806	\$ (7,526.85)	\$	10,496.10	\$	9,375.00	\$ (6,405.75)	MARKETING EDUCATION
145 L 00000 002 000 15000 950	\$ (474.00)	\$	-	\$	-	\$ (474.00)	MATH
145 L 00000 003 000 15000 950	\$ -	\$	-	\$	-	\$ -	MATH
145 L 00000 001 000 15000 950	\$ (52.36)	\$	-	\$	-	\$ (52.36)	MATH - HILL
145 L 00000 000 000 15000 955	\$ (1,687.07)	\$	-	\$	-	\$ (1,687.07)	MERCY / BENEVOLENCE FUND
145 L 00000 000 000 15000 909	\$ (0.93)	\$	-	\$	-	\$ (0.93)	MIDDLE SCHOOL BAND
145 L 00000 000 000 15000 915	\$ -	\$	-	\$	-	\$ -	MIDDLE SCHOOL BAND
145 L 00000 000 000 15000 844	\$ (34.95)	\$	-	\$	-	\$ (34.95)	MULTICULTURAL CLUB
145 L 00000 000 000 15000 832	\$ (1,288.75)	\$	-	\$	-	\$ (1,288.75)	NATIONAL HONOR SOCIETY
145 L 00000 000 000 15000 805	\$ (154.47)	\$	-	\$	-	\$ (154.47)	OUTDOOR ADVENTURE
145 L 00000 001 000 15000 912	\$ (2,627.83)	\$	-	\$	-	\$ (2,627.83)	PAUL KEYS SCHOLARSHIP
145 L 00000 000 000 15000 834	\$ (70.68)	\$	-	\$	-	\$ (70.68)	PEP CLUB
145 L 00000 000 000 15000 835	\$ -	\$	-	\$	-	\$ -	PHOTOGRAPHY CLUB
145 L 00000 001 000 15000 954	\$ (8.57)	\$	-	\$	-	\$ (8.57)	PHYSICAL SCIENCE - JENNINGS
145 L 00000 002 000 15000 954	\$ -	\$	-	\$	-	\$ -	PHYSICAL SCIENCE - RHOTON
145 L 00000 000 000 15000 957	\$ (371.28)	\$	-	\$	-	\$ (371.28)	PHYSICS
145 L 00000 003 000 15000 903	\$ -	\$	-	\$	-	\$ -	QUEST GRANT (RHOTON)
145 L 00000 000 000 15000 986	\$ (699.87)	\$	-	\$	-	\$ (699.87)	RESOURCE CDC
145 L 00000 000 000 15000 925	\$ -	\$	-	\$	-	\$ -	ROTC RANGE IMPROVEMENT GRANT
145 L 00000 003 000 15000 912	\$ (10,846.82)	\$	124.03	\$	2,800.00	\$ (13,522.79)	ROTC SCHOLARSHIP
145 L 00000 000 000 15000 841	\$ (194.37)	\$	-	\$	-	\$ (194.37)	RURI-TEEN CLUB
145 L 00000 000 000 15000 912	\$ (7,450.00)	\$	-	\$	-	\$ (7,450.00)	SCHOLARSHIPS
145 L 00000 000 000 15000 968	\$ (1,000.13)	\$	-	\$	-	\$ (1,000.13)	SCHOOL INCENTIVES
145 L 00000 001 000 15000 981	\$ (268.39)	\$	-	\$	-	\$ (268.39)	SCIENCE - CARR
145 L 00000 000 000 15000 982	\$ -	\$	-	\$	-	\$ -	SCIENCE DEPARTMENT GRANT
145 L 00000 000 000 15000 810	\$ -	\$	-	\$	-	\$ -	SCIENCE OLYMPIAD
145 L 00000 000 000 15000 981	\$ (10.00)	\$	-	\$	-	\$ (10.00)	SCIENCE-716-HORN
145 L 00000 000 000 15000 715	\$ (261.09)	\$	289.98	\$	300.00	\$ (271.11)	SCIENCE-HORN
145 L 00000 000 000 15000 850	\$ (21,520.01)	\$	246.07	\$	2,238.29	\$ (23,512.23)	SCRIB ACCOUNT
145 L 00000 000 000 15000 921	\$ (1,414.00)	\$	6,059.40	\$	5,196.00	\$ (550.60)	SKILLS
145 L 00000 000 000 15000 610	\$ (79.66)	\$	-	\$	-	\$ (79.66)	SOCCER
145 L 00000 000 000 15000 983	\$ (226.12)	\$	-	\$	-	\$ (226.12)	SOCIAL STUDIES - ECONOMICS
145 L 00000 000 000 15000 984	\$ (16.09)	\$	-	\$	-	\$ (16.09)	SOCIAL STUDIES - GOVERNMENT
145 L 00000 000 000 15000 609	\$ (7,666.22)	\$	4,718.26	\$	13,040.00	\$ (15,987.96)	SOFTBALL
145 L 00000 000 000 15000 922	\$ -	\$	-	\$	-	\$ -	SONGWRITING
145 L 00000 000 000 15000 843	\$ (510.06)	\$	-	\$	-	\$ (510.06)	SPANISH CLUB
145 L 00000 000 000 15000 977	\$ (7.22)	\$	331.37	\$	480.00	\$ (155.85)	SPECIAL EDUCATION
145 L 00000 000 000 15000 845	\$ (225.02)	\$	1,058.80	\$	1,025.00	\$ (191.22)	STUDENT COUNCIL
145 L 00000 000 000 15000 991	\$ (3,421.70)	\$	782.46	\$	-	\$ (2,639.24)	STUDENT NEEDS
145 L 00000 000 000 15000 927	\$ (295.00)	\$	100.00	\$	140.00	\$ (335.00)	TAP
145 L 00000 000 000 15000 618	\$ -	\$	-	\$	-	\$ -	TRACK
145 L 00000 000 000 15000 847	\$ (37.82)	\$	-	\$	-	\$ (37.82)	TRI M MUSIC HONOR SOCIETY
145 L 00000 000 000 15000 848	\$ (2,701.56)	\$	2,429.24	\$	2,432.12	\$ (2,704.44)	TSA
145 L 00000 000 000 15000 611	\$ (9,216.91)	\$	21,041.21	\$	21,199.29	\$ (9,374.99)	VOLLEYBALL
145 L 00000 000 000 15000 798	\$ (124,444.37)	\$	6,617.48	\$	134.89	\$ (117,961.78)	WANDA B DUGGER TRUST-BIOLOGY
145 L 00000 000 000 15000 799	\$ (122,909.91)	\$	9,671.28	\$	-	\$ (113,238.63)	WANDA B DUGGER TRUST-CHEMISTRY
145 L 00000 000 000 15000 612	\$ -	\$	750.46	\$	2,225.00	\$ (1,474.54)	WRESTLING
145 L 00000 000 000 15000 899	\$ (40,854.58)	\$	7,241.41	\$	-	\$ (33,613.17)	YEARBOOK

Total L-Account Balances	\$ (783,702.81)
Total A-Account Balances	\$ 848,033.15

Unreconciled	Total Unrestricted Funds	\$ 64,330.34
---------------------	---------------------------------	---------------------

DCHS Chart of Accounts
L-Accounts are Restricted Accounts
3/23/2026

Account Number						Beginning Balance	Debit Amount	Credit Amount	Ending Balance	Account Level Description	
Fnd T	Acct	Obj	Prj	Loc	Prg						
145	A	00000	000	000	16000	100	\$ 609,541.73	\$ 541,991.38	\$ 543,015.32	\$ 608,517.79	CASH IN BANK - CHECKING

Account Number						Beginning Balance	Debit Amount	Credit Amount	Ending Balance	Account Level Description	
Fnd T	Acct	Obj	Prj	Loc	Prg						
145	L	00000	000	000	16000	904	\$ (37.88)	\$ -	\$ -	\$ (37.88)	ADVANCED COMPOSITION
145	L	00000	000	000	16000	809	\$ (116.00)	\$ -	\$ -	\$ (116.00)	AGRICULTURAL MECHANICS
145	L	00000	000	000	16000	907	\$ -	\$ -	\$ -	\$ -	ANNUAL BANQUET FUND
145	L	00000	000	000	16000	803	\$ (20.00)	\$ -	\$ -	\$ (20.00)	ARK CLUB
145	L	00000	000	000	16000	913	\$ (16,113.56)	\$ 3,279.19	\$ 3,600.00	\$ (16,434.37)	ART
145	L	00000	000	000	16000	600	\$ (38,023.24)	\$ 151,573.70	\$ 159,303.57	\$ (45,753.11)	ATHLETICS
145	L	00000	000	000	16000	620	\$ (667.95)	\$ 6,527.78	\$ 12,273.28	\$ (6,413.45)	ATHLETICS - MIDDLE SCHOOL
145	L	00000	000	000	16000	602	\$ (2,594.67)	\$ -	\$ -	\$ (2,594.67)	ATHLETICS - RESERVE
145	L	00000	000	000	16000	617	\$ (440.00)	\$ -	\$ -	\$ (440.00)	ATHLETICS - SPECIAL PROJECTS
145	L	00000	000	000	16000	614	\$ (5,305.21)	\$ 1,974.70	\$ 181.00	\$ (3,511.51)	ATHLETICS - TRAINING
145	L	00000	000	000	16000	804	\$ (5,282.99)	\$ 5,003.47	\$ 5,268.00	\$ (5,547.52)	AUDIO VISUAL
145	L	00000	000	000	16000	806	\$ (2,105.50)	\$ 1,594.30	\$ 850.00	\$ (1,361.20)	AUTO MECHANICS
145	L	00000	000	000	16000	914	\$ (1,273.12)	\$ 8,308.29	\$ 14,200.00	\$ (7,164.83)	BAND
145	L	00000	000	000	16000	604	\$ (534.00)	\$ -	\$ 150.00	\$ (684.00)	BASEBALL
145	L	00000	000	000	16000	605	\$ (12,685.22)	\$ 51,690.35	\$ 53,027.63	\$ (14,022.50)	BASKETBALL - BOYS
145	L	00000	001	000	16000	605	\$ -	\$ -	\$ -	\$ -	BASKETBALL - BOYS
145	L	00000	000	000	16000	603	\$ -	\$ -	\$ -	\$ -	BASKETBALL - FRESHMAN BOYS
145	L	00000	003	000	16000	605	\$ -	\$ -	\$ -	\$ -	BASKETBALL - FRESHMAN BOYS
145	L	00000	000	000	16000	615	\$ (8,044.55)	\$ 8,596.33	\$ 7,477.42	\$ (6,925.64)	BASKETBALL - GIRLS
145	L	00000	002	000	16000	605	\$ -	\$ -	\$ -	\$ -	BASKETBALL - GIRLS
145	L	00000	002	000	16000	615	\$ -	\$ -	\$ -	\$ -	BASKETBALL - GIRLS
145	L	00000	000	000	16000	807	\$ (1,208.19)	\$ 416.00	\$ 563.00	\$ (1,355.19)	BETA CLUB
145	L	00000	000	000	16000	808	\$ (200.68)	\$ -	\$ -	\$ (200.68)	BIBLE CLUB
145	L	00000	000	000	16000	970	\$ (322.12)	\$ -	\$ -	\$ (322.12)	BOARD ALLOCATION - ATTENDANCE
145	L	00000	000	000	16000	971	\$ (7,120.69)	\$ 585.58	\$ -	\$ (6,535.11)	BOARD ALLOCATION - COPIER
145	L	00000	000	000	16000	972	\$ (1,500.00)	\$ -	\$ -	\$ (1,500.00)	BOARD ALLOCATION - MATERIALS
145	L	00000	000	000	16000	811	\$ (793.06)	\$ -	\$ 1,222.00	\$ (2,015.06)	BUSINESS PROFESSIONALS OF AMER
145	L	00000	000	000	16000	606	\$ (18,560.92)	\$ 18,421.67	\$ 10,589.11	\$ (10,728.36)	CHEERLEADING
145	L	00000	000	000	16000	851	\$ (150.58)	\$ -	\$ -	\$ (150.58)	CHESS CLUB
145	L	00000	000	000	16000	857	\$ (18.65)	\$ -	\$ -	\$ (18.65)	CHICK-FIL-A ACADEMY
145	L	00000	000	000	16000	923	\$ (7,952.92)	\$ 16,062.22	\$ 15,829.00	\$ (7,719.70)	CHORUS
145	L	00000	000	000	16000	810	\$ (274.93)	\$ 3,315.61	\$ 4,956.00	\$ (1,915.32)	CIVINETTES
145	L	00000	000	000	16000	812	\$ -	\$ -	\$ -	\$ -	CIVINETTES
145	L	00000	000	000	16000	715	\$ -	\$ -	\$ -	\$ -	CLASS OF 2015
145	L	00000	000	000	16000	722	\$ (4,992.86)	\$ 1,807.32	\$ 1,811.00	\$ (4,996.54)	CLASS OF 2026
145	L	00000	000	000	16000	724	\$ (7,197.10)	\$ 300.00	\$ 1,753.80	\$ (8,650.90)	CLASS OF 2027
145	L	00000	000	000	16000	716	\$ (4,478.34)	\$ -	\$ -	\$ (4,478.34)	CLASS OF 2028
145	L	00000	000	000	16000	717	\$ (13,847.30)	\$ 290.00	\$ 2,055.00	\$ (15,612.30)	CLASS OF 2029
145	L	00000	000	000	16000	925	\$ (156.86)	\$ -	\$ -	\$ (156.86)	COLLEGE CORNER
145	L	00000	000	000	16000	926	\$ -	\$ -	\$ -	\$ -	COMPOSITION
145	L	00000	000	000	16000	928	\$ (3,005.74)	\$ 2,274.49	\$ 1,640.00	\$ (2,371.25)	COSMETOLOGY
145	L	00000	000	000	16000	619	\$ (7,635.66)	\$ 16,590.19	\$ 16,844.06	\$ (7,889.53)	CROSS COUNTRY
145	L	00000	000	000	16000	621	\$ (1,670.21)	\$ 191.53	\$ 1,902.00	\$ (3,380.68)	DANCE TEAM
145	L	00000	000	000	16000	839	\$ -	\$ -	\$ -	\$ -	DCHS GEARHEADS
145	L	00000	000	000	16000	813	\$ (4,933.62)	\$ 364.99	\$ 605.00	\$ (5,173.63)	DECA
145	L	00000	000	000	16000	711	\$ (4,851.24)	\$ -	\$ -	\$ (4,851.24)	DIVERSIFIED TECHNOLOGY
145	L	00000	000	000	16000	930	\$ (5,247.26)	\$ -	\$ -	\$ (5,247.26)	DRAFTING
145	L	00000	000	000	16000	814	\$ (4,904.22)	\$ 1,148.00	\$ 144.00	\$ (3,900.22)	DRAMA CLUB
145	L	00000	000	000	16000	931	\$ (212.87)	\$ -	\$ -	\$ (212.87)	DRIVERS EDUCATION
145	L	00000	000	000	16000	826	\$ (265.00)	\$ -	\$ -	\$ (265.00)	DUNGEON & DRAGONS CLUB
145	L	00000	000	000	16000	805	\$ (247.41)	\$ 1,672.71	\$ 2,088.60	\$ (663.30)	ELECTRICAL CARPENTRY
145	L	00000	000	000	16000	830	\$ (233.67)	\$ -	\$ -	\$ (233.67)	EMR/EKG
145	L	00000	000	000	16000	934	\$ (138.71)	\$ -	\$ -	\$ (138.71)	ENGLISH
145	L	00000	000	000	16000	816	\$ (2.52)	\$ -	\$ -	\$ (2.52)	ENVIROTHON
145	L	00000	000	000	16000	969	\$ (26.89)	\$ -	\$ -	\$ (26.89)	EPIC
145	L	00000	000	000	16000	908	\$ (2,006.80)	\$ -	\$ -	\$ (2,006.80)	EPSO Grant
145	L	00000	000	000	16000	958	\$ (147.68)	\$ 50.00	\$ 400.00	\$ (497.68)	FACULTY FUND
145	L	00000	000	000	16000	936	\$ (166.59)	\$ -	\$ -	\$ (166.59)	FARM ACCOUNT
145	L	00000	000	000	16000	818	\$ (775.75)	\$ 775.75	\$ -	\$ -	FCLA
145	L	00000	000	000	16000	817	\$ (20,325.52)	\$ 8,200.40	\$ 5,370.00	\$ (17,495.12)	FELLOWSHIP OF CHRISTIAN ATHLET
145	L	00000	000	000	16000	819	\$ (4,960.48)	\$ 10,830.36	\$ 11,204.00	\$ (5,334.12)	FFA
145	L	00000	000	000	16000	820	\$ (25,000.00)	\$ -	\$ -	\$ (25,000.00)	FFA HORTICULTURE
145	L	00000	000	000	16000	821	\$ (10,149.71)	\$ 4,500.90	\$ 30.00	\$ (5,678.81)	FIRST ROBOTICS

145 L 00000 000 000 16000 607	\$	(13,912.15)	\$	37,358.22	\$	32,353.84	\$	(8,907.77)	FOOTBALL
145 L 00000 000 000 16000 822	\$	(787.87)	\$	105.00	\$	-	\$	(682.87)	FRENCH CLUB
145 L 00000 000 000 16000 801	\$	(64.87)	\$	189.00	\$	382.00	\$	(257.87)	FUTURE TEACHERS OF AMERICA
145 L 00000 000 000 16000 823	\$	(190.98)	\$	-	\$	-	\$	(190.98)	GERMAN CLUB
145 L 00000 000 000 16000 815	\$	-	\$	-	\$	-	\$	-	GO-KART
145 L 00000 000 000 16000 608	\$	(1,058.75)	\$	4,482.50	\$	3,440.00	\$	(16.25)	GOLF
145 L 00000 001 000 16000 608	\$	(39.26)	\$	-	\$	-	\$	(39.26)	GOLF - MIDDLE SCHOOL
145 L 00000 000 000 16000 910	\$	(1.00)	\$	-	\$	-	\$	(1.00)	GRAD GIVES
145 L 00000 000 000 16000 714	\$	(1,086.12)	\$	-	\$	607.00	\$	(1,693.12)	GRADUATION
145 L 00000 000 000 16000 940	\$	(62,431.33)	\$	25,785.80	\$	9,910.26	\$	(46,555.79)	GRAPHIC ARTS
145 L 00000 001 000 16000 940	\$	-	\$	-	\$	-	\$	-	GRAPHIC ARTS CENTRAL OFFICE
145 L 00000 000 000 16000 906	\$	(594.25)	\$	-	\$	1,020.00	\$	(1,614.25)	GUIDANCE
145 L 00000 000 000 16000 740	\$	(5,390.74)	\$	7,821.46	\$	6,651.82	\$	(4,221.10)	GUIDANCE/BENEVOLENCE
145 L 00000 000 000 16000 613	\$	(2,000.03)	\$	37,814.33	\$	35,814.30	\$	-	HARDEE'S CLASSIC/ SPECIAL TOUR
145 L 00000 000 000 16000 833	\$	(282.88)	\$	-	\$	2,000.00	\$	(2,282.88)	HARDEE'S SCHOLARSHIPS
145 L 00000 000 000 16000 824	\$	(1,053.56)	\$	6,612.51	\$	10,420.00	\$	(4,861.05)	HEALTH OCCUPATIONS
145 L 00000 000 000 16000 825	\$	(400.00)	\$	-	\$	-	\$	(400.00)	HIKING CLUB
145 L 00000 000 000 16000 942	\$	(50,592.99)	\$	24,108.59	\$	17,292.43	\$	(43,776.83)	HOME ECONOMICS
145 L 00000 000 000 16000 622	\$	-	\$	-	\$	-	\$	-	INDOOR ATHLETIC FACILITY
145 L 00000 000 000 16000 831	\$	(539.15)	\$	84.60	\$	277.00	\$	(731.55)	INTERNATIONAL LANGUAGE CLUB
145 L 00000 000 000 16000 802	\$	(426.89)	\$	-	\$	-	\$	(426.89)	JOURNALISM
145 L 00000 000 000 16000 828	\$	(5,375.05)	\$	2,442.00	\$	4,274.00	\$	(7,207.05)	KEY CLUB
145 L 00000 000 000 16000 962	\$	(544.01)	\$	-	\$	20.00	\$	(564.01)	LIBRARY
145 L 00000 000 000 16000 947	\$	(1,685.33)	\$	1,253.98	\$	2,271.00	\$	(2,702.35)	MACHINE SHOP
145 L 00000 000 000 16000 938	\$	(7,803.29)	\$	-	\$	-	\$	(7,803.29)	MACHINE SHOP GRANT- GENE HAAS
145 L 00000 000 000 16000 949	\$	(431.29)	\$	932.20	\$	1,059.00	\$	(558.09)	MASONRY
145 L 00000 000 000 16000 950	\$	(10,495.58)	\$	59.40	\$	765.00	\$	(11,201.18)	MATH
145 L 00000 000 000 16000 616	\$	(337.50)	\$	-	\$	-	\$	(337.50)	MEN'S VOLLEYBALL
145 L 00000 000 000 16000 955	\$	(3,368.84)	\$	709.00	\$	584.00	\$	(3,243.84)	MERCY
145 L 00000 000 000 16000 951	\$	-	\$	-	\$	-	\$	-	MINI LIBRARY
145 L 00000 000 000 16000 832	\$	(129.50)	\$	-	\$	300.00	\$	(429.50)	MYTHS & LEGENDS
145 L 00000 000 000 16000 742	\$	(2,938.03)	\$	-	\$	-	\$	(2,938.03)	NEEDY STUDENT FUND
145 L 00000 000 000 16000 953	\$	(311.05)	\$	-	\$	-	\$	(311.05)	NORTHEAST SECONDARY PRINCIPALS
145 L 00000 000 000 16000 911	\$	(1,400.00)	\$	-	\$	-	\$	(1,400.00)	PARTNERS IN CAREER TECH EDUCAT
145 L 00000 000 000 16000 834	\$	(256.60)	\$	-	\$	-	\$	(256.60)	PEP CLUB
145 L 00000 000 000 16000 835	\$	(30.02)	\$	-	\$	-	\$	(30.02)	PHOTO CLUB
145 L 00000 000 000 16000 623	\$	-	\$	-	\$	75.00	\$	(75.00)	PICKLEBALL CLUB
145 L 00000 000 000 16000 836	\$	(2,216.36)	\$	36,345.77	\$	36,132.20	\$	(2,002.79)	PIONEER ATHLETICS CLUB
145 L 00000 000 000 16000 856	\$	(267.24)	\$	590.00	\$	1,839.93	\$	(1,517.17)	PIONEER PLAYERS
145 L 00000 000 000 16000 960	\$	(189.11)	\$	-	\$	-	\$	(189.11)	PRE-VOCATIONAL
145 L 00000 000 000 16000 956	\$	(3,396.97)	\$	100.04	\$	2,000.00	\$	(5,296.93)	PRINCIPAL'S INCENTIVE
145 L 00000 000 000 16000 965	\$	-	\$	-	\$	-	\$	-	PROJECT STAR
145 L 00000 000 000 16000 838	\$	(230.00)	\$	-	\$	-	\$	(230.00)	RADIO CLUB
145 L 00000 000 000 16000 829	\$	(655.74)	\$	-	\$	-	\$	(655.74)	RECYCLE CLUB
145 L 00000 001 000 16000 977	\$	(4,604.69)	\$	4,725.66	\$	3,030.00	\$	(2,909.03)	ROTC - MISCELLANEOUS
145 L 00000 002 000 16000 978	\$	-	\$	-	\$	-	\$	-	ROTC - MISCELLANEOUS
145 L 00000 001 000 16000 978	\$	(18,920.22)	\$	40,241.55	\$	38,508.13	\$	(17,186.80)	ROTC - OFFICERS
145 L 00000 000 000 16000 979	\$	(520.69)	\$	-	\$	-	\$	(520.69)	RURITAN
145 L 00000 000 000 16000 842	\$	(100.00)	\$	-	\$	-	\$	(100.00)	SCHOLARS BOWL
145 L 00000 000 000 16000 912	\$	(95.00)	\$	-	\$	-	\$	(95.00)	SCHOLARSHIPS
145 L 00000 000 000 16000 981	\$	(5,982.57)	\$	3,971.52	\$	4,561.00	\$	(6,572.05)	SCIENCE
145 L 00000 000 000 16000 855	\$	(961.91)	\$	1,863.59	\$	2,775.00	\$	(1,873.32)	SCRIB ACCOUNT
145 L 00000 000 000 16000 843	\$	(325.58)	\$	-	\$	-	\$	(325.58)	SENIOR SECTION LEADERS
145 L 00000 000 000 16000 849	\$	(5,059.38)	\$	9,689.92	\$	11,159.07	\$	(6,528.53)	SKILLS USA
145 L 00000 001 000 16000 610	\$	(1,148.32)	\$	-	\$	-	\$	(1,148.32)	SOCCER - BOYS
145 L 00000 002 000 16000 610	\$	(5,959.53)	\$	5,408.35	\$	5,690.00	\$	(6,241.18)	SOCCER - GIRLS
145 L 00000 000 000 16000 710	\$	(1,516.63)	\$	39.42	\$	410.00	\$	(1,887.21)	SOCIAL STUDIES
145 L 00000 000 000 16000 609	\$	(5,043.07)	\$	2,917.11	\$	4,480.00	\$	(6,605.96)	SOFTBALL
145 L 00000 000 000 16000 985	\$	(1,617.20)	\$	1,010.50	\$	1,000.00	\$	(1,606.70)	SPANISH
145 L 00000 000 000 16000 827	\$	(411.29)	\$	194.26	\$	-	\$	(217.03)	SPANISH HONOR SOCIETY
145 L 00000 000 000 16000 601	\$	(218.90)	\$	-	\$	-	\$	(218.90)	STAR WALK OF FAME
145 L 00000 000 000 16000 845	\$	(1,418.85)	\$	2,014.73	\$	4,112.45	\$	(3,516.57)	STUDENT COUNCIL
145 L 00000 000 000 16000 992	\$	-	\$	-	\$	-	\$	-	STUDENT OF THE MONTH
145 L 00000 000 000 16000 997	\$	(538.82)	\$	-	\$	-	\$	(538.82)	TITLE READING
145 L 00000 000 000 16000 618	\$	(4,049.44)	\$	2,022.51	\$	4,849.00	\$	(6,875.93)	TRACK
145 L 00000 000 000 16000 858	\$	-	\$	-	\$	-	\$	-	TSA - TECHNOLOGY STUDENT ASSOC
145 L 00000 000 000 16000 837	\$	-	\$	-	\$	-	\$	-	TURNING POINT USA
145 L 00000 000 000 16000 611	\$	(1,107.70)	\$	746.94	\$	1,473.00	\$	(1,833.76)	VOLLEYBALL
145 L 00000 000 000 16000 999	\$	(1,454.71)	\$	3,761.93	\$	4,955.00	\$	(2,647.78)	WELDING
145 L 00000 002 000 16000 912	\$	(1,455.24)	\$	-	\$	-	\$	(1,455.24)	WLC
145 L 00000 000 000 16000 612	\$	(65.86)	\$	6,534.45	\$	8,300.56	\$	(1,831.97)	WRESTLING
145 L 00000 001 000 16000 612	\$	-	\$	-	\$	-	\$	-	WRESTLING - MIDDLE SCHOOL
145 L 00000 000 000 16000 899	\$	(14,020.17)	\$	3,966.32	\$	1,894.00	\$	(11,947.85)	YEARBOOK

145 L 00000 000 000 16000 850 \$ (7.50) \$ - \$ - \$ (7.50) YOGA CLUB

	Total L-Account Balances	\$	(518,218.71)
	Total A-Account Balances	\$	608,517.79
Unreconciled	Total Unrestricted Funds	\$	90,299.08

Intent to Apply/Research	Grants Writer/Manager's Report	April 2026					
Tennessee Council for Career and Technical Education (TCCTE)	No announcement as of today. For Professional Development to a National Conference for Health Science Teachers in the district. Requesting \$11,656.94						
Toshiba America Foundation	No announcement as of today. DCHS Teacher submitted Toshiba grant for \$9,000 for a portable welding equipment.						
Project Diabetes forecasted	Would like WCG to reapply for Project Diabetes for pickleball courts.	This past grant cycle they did not award any school systems but only governments and nonprofits	Update: this grant will open back up in year 2028				
BJA FY 25 Student, Teachers, and Officers Preventing (STOP) School Violence Grant	This grant award has not been announced.						
USDA Equipment Grant	Forecasted to be available for school cafeteria equipment.						
Working with First Tennessee Development District and WCEDC	Continue the partnership process in implementing the logistics of the daycare and as a partner, following the guidelines of the grant award guidelines.						
Dollar General Foundation	This grant has been submitted. Summer Reading Grant for Book Bus Requesting \$3,000. Submitted and award announcement will be May 8, 2026.						
Dollar General Foundation	This grant has been submitted. Youth Literacy Grant is upto \$5,000. Will be working with Academic Specialist for RTI2 materials for districtwide support. Grant opens March 6, 2026. One other school was also working on this grant.						
Perkins V Reserve	Currently working on this grant application with CTE Director. Grant is upto \$50,000. Must focus on 4 pillars of the CTE program.						
Google.org AI Ecosystems Application	No award announcement as of today. In collaboration between Operations and Academics grant was submitted for a 80% Google to 20% WCS match for a partnership with PlayLab. This partnership will provide training and software. Approximately a value of \$26,480 or more depending on finalized service agreement if awarded.						

National Education Association	No award announcement as of today. Lamar teacher is applying for the NEA Professional Development grant (\$2500) to receive Orton-Gillingham Training to support intervention program.
Lottery for Education Afterschool Program	In partnership with Coalition 4 Kids, they will be the lead applicant for our remaining schools to support afterschool programs. Coalition 4 Kids goal is to provide the afterschool programs throughout the school system.
School Nutrition Association Winston Equipment Grant	No announcements as of today. This grant has been submitted, February 2026, to support DCHS, Lamar, and West View cafeterias. The value of the grant is up to \$50,000 in CVap Holding cabinets. It is a National competition in which they allocate 2 awards. It is a two round grant, first is the written application and then the second round is invention only to create and submit a video. We won the Vulcan version (ovens) of this grant process in 2022. Our video is posted on their website. https://vimeo.com/showcase/10930749?video=744233079
Grants Awarded	
Governor's Early Literacy Program	Donation of 200 books for the Bookmobile.
Grants Managed	
VW grant middle and heavy duty ve	<i>VW STATE GRANT is awarded. Washington County Schools is the fiscal agent for reimbursement requests for this state award. Grant award \$309,171.00 the balance would need to be funded by district funds.</i>
Ballad Health	\$5,000 award for David Crockett High School to provide Digital Printing equipment, supplies, and other materials to create promotional items in supporting Suicide Awareness Program. The equipment will make items such as T-Shirts and will create financial sustainability for future Suicide Awareness Programs.
TN Civics Grant (2 awards)	SSES and Gray Elementary Schools are applying for \$5,000 each to provide professional development, student educational experience, and foundation materials and other civics driven learning platforms. This grant will help in providing evidence in the application for the School Governor's Civics Seal. Both schools have been awarded in February, 2026.
TDOE Advancing Mental Health Pilot	Coordinated School Health was awarded \$5,000 to support Youth Mental Health First Aid Training for nurses and counselors.

United Way East TN Highlands	United Way of East Tennessee Highlands, sponsored a book drive for area book buses, we are one of 4 districts whose book bus is sponsored.						
TN Tutoring Grant	Academic Department was awarded \$81,600 to provide tutoring support for students in K-8. They will be managing their award. This grant will pay stipends for tutors and other supporting supplies/materials. This grant is a bridge from our previous TN All Corps tutoring program. Same rules apply high-dosage small-ratio programing.						
TDOE Advancing Mental Health Pilot	Coordinated School Health was awarded \$5,000 to support Youth Mental Health First Aid Training for nurses and counselors and attend a conference.						
Gear Up grant - ETSU	In partnership with ETSU Trio: working on contracts.	7 year grant: Goal is to start program in January, 2026. GEAR UP team includes Kelli Hauldren, Cindy Hayes, Twana McKinney, and Billy Stepp.	To provide 4 GEAR UP coordinators to work district-wide with 7th grade cohort through 1st year post-secondary.	A state-specific initiative that operates under the national Gaining Early Awareness and Readiness for Undergraduate Programs (GEAR UP) federal grant, which aims to increase the number of low-income students prepared for and succeeding in postsecondary education.			
ISM Grant	PLEASE NOTE: ISM funds has helped to support middle school CTE/STEM teachers and one high school CTE teacher. This grant ends in JUNE, 2026. Sustainability for the program to continue will start July 2026, if the School Board chooses to keep this positions.			Help CTE Director update FY 26 ISM application and monthly payroll calculation and reimbursement requests	This year teachers are 25% match funded	Note: schools involved in this grant were awarded (allocated FY2023) BCE \$500,000, DB \$1,000,000, DC \$1,000,000, FB \$200,000, GV \$500,000, Gray \$500,000, JES \$500,000, RV \$500,000, SC \$200,000, SS \$500,000, University \$1,000,000, WV \$500,000	
TN Economic Community Development (ECD) Three Star Grant	PLEASE NOTE: these grants are only good for two (2) years from the start of the award. The funds must be used within the two year allocation of the award.	WCEDC was awarded \$250,000 for construction costs related to improvements for a childcare facility. Washington County Economic Development partnered with WCS to place a new community childcare facility. The partners do plan on having a play area for the children to play outside.		Still working on contract language agreement.	August 26, 2025		
The public daycare center grants' MOUs are being drafted. The TVA Workforce Invest Grant has been awarded to the team for \$250,000. The Education Invest grant was awarded \$250,000.				WCS in partnership with Economic Development, City of Johnson City, and First Tennessee Development District.			
Public School Security Grant	Allocation:	\$162,221.01	Funding will support fencing, access controls, and barriers for walkways, signs and locking mechanisms for doors. Doors have been purchased and fencing has been bidded out and decided.				
Lottery for Education Afterschool Program	\$75,000	Year 6 of the LEAPS program at South Central Elementary	This is the final year of this LEAPS grant cohort	Program director for this grant funded program	This will be an in-person monitoring year	Provide all necessary documentation into Department of Human Services Child Care Provider Portal to renew the SCES LEAPS site for continuing service	Help with any grant related to personnel, data reporting, purchases, and deliver orientation meetings, and attend meetings with the state department.
Comprehensive School Mental Health System pilot	The Comprehensive School Mental Health Implementation Pilot will equip participating districts and their respective schools with the tools and resources necessary to amplify existing mental health infrastructure.			The Comprehensive School Mental Health Implementation Pilot aims to strengthen and enhance mental health in schools by integrating systems, programs, and resources. Participating districts will receive personalized training, technical support, and resources that will enhance existing infrastructure to meet the needs of students, staff, and the school community.			
Book Bus	Assisting in the collaboration between the Book Bus and the Districtwide Family Resource Program. Initiating a pilot program by combining opportunities of receiving resources under the Family Resource Program and their partners (potential grants) and books by provided by grants and donations by using the Book Bus as a mobile hub throughout Washington County Communities.			Receive Books from Scholastic through GELF.			

GVES	5/14/2026	Paradise Acres & Willow Springs Park				
GVES	4/7/2026	Johnson City Library				
DCHS	4/2/2026	Grandview Elementary Family Night				
FBES	5/14/2026	Warrior Path State Park				
SSES	3/27/2026	Henderson Wetlands				
GVES	5/4/2026	David Crockett High School Annual 8th Grade Choral Field Trip				
DCHS	4/15/2026	McDowell H.S. in Marion, NC				
LES	5/7/2026	Papa John's and Golden Oak Park in Jonesborough				
LES	4/23/2026	Bright's Zoo - 3425 HWY 11E, Jonesborough TN 37659				
SSES	5/14/2026	Andrew Johnson Historical Site				
RVES	5/11/2026	Tiebreakers in Johnson City				
JES	5/8/2026	Paradise Acres- 4946 N Roan St, Johnson City, TN 37615				
SSES	5/7/2026	Daniel Boone High School				
RVES	5/8/2026	Chuck E Cheese (3020 Peoples St., Johnson City, TN)				
SSES	5/19/2026	Just Jump and Johnson City Mall				
DBHS	5/1/2026	Northeast State Community College				
DCHS	5/1/2026	Local Fire and Police departments and DCHS feeder schools				
WVES	5/8/2026	Dollywood				
WVES	4/23/2026	CareerQuest ETSU				
DBHS	4/7/2026	Northeast State Community College				
SSES	5/11/2026	East Tennessee Historical Society				
SSES	5/7/2026	Andrew Johnson Historical Site				
SSES	4/30/2026	TVA Boone Dam				
SSES	5/14/2026	ETSU Resilient Schools Student Leadership Summit				
DCHS	5/15/2026	The Funny Farm, Chuckey, TN				
DBHS	4/17/2026	Gray, Appalachian Fairgrounds				
JES	4/17/2026	David Crockett High School				
SCES	5/19/2026	Bright's Zoo				
GES	4/23/2026	CareerQuest at ETSU, Willow Springs Park				
BCES	4/28/2026	Bays Mountain 853 Bays Mountain Park Road Kingsport, TN 37660				
DCHS	4/23/2026	Bright's Zoo with her TAP placement students and teachers at Lamar.				
DCHS	5/12/2026	The Funny Farm, Chuckey, TN				
DCHS	5/15/2026	Graduation Practice, ETSU Mini Dome				
GES	5/15/2026	Camp Tapawingo				
DCHS	5/15/2026	Graduation Practice, ETSU Mini Dome				

DCHS	4/2/2026	Grandview Elementary				
BCES	5/18/2026	Dollywood				
LES	5/12/2026	Tie-Breakers (1805 N. Roan St. Johnson City) and Willow Springs Park (1201 Huffine Rd. Johnson City)				
BCES	4/25/2026	TSSBDA Concert Festival - Perform at Union High School, TN (Maynardville, TN) and then the West Town Mall (for lunch/dinner)				
BCES	5/19/2026	Holiday Lanes to bowl and the Johnson City Mall Food Court				
GES	5/20/2026	Bays Mountain Park and Planetarium in Kingsport				
DCHS	4/21/2026	Grandfather Mountain				
GVES	5/6/2026	Brights Zoo Reading Buddies trip with PreK				
GVES	5/7/2026	Clyde Austin 4-H Center 214 4-H Ln, Greeneville, TN				
SSES	5/19/2026	Paradise Acres, Boones Creek				
BCES	5/14/2026	Path Finders				
GVES	5/6/2026	Bright's Zoo				
SSES	4/23/2026	East Tennessee State University				
DBHS	4/24/2026	Jefferson County High School				
FBES	5/4/2026	Paradise Acres (4946 N Roan St, Johnson City, TN 37615)				
GES	5/8/2026	Andrew Johnson Historical Site				
GES	5/13/2026	Andrew Johnson Historical Site				
RVES	4/23/2026	Career Quest, ETSU				

<i>REQ DATE</i>
03/11/2026

Washington County Schools Nutrition

405 West College Street
 Jonesborough, TN 37659
 423-753-1107
 nutrition@wcde.org

<i>REQUISITION NUMBER</i>
1430260255

VENDOR KEY : PEPSI-CO000
 SHIP DATE : 03/11/2026
 FISCAL YEAR : 2025-2026
 ENTERED BY : HARTGCHL000

PRINTED 03/19/2026

VENDOR:
 PEPSI-COLA COMPANY
 PO Box 75948
 CHICAGO, IL 60675-5948

SHIP TO:
 Washington County Schools - Food Service
 405 W COLLEGE ST
 JONESBOROUGH, TN 37659

ATTN: CHLOE HARTGROVE

QUANTITY	UNIT	DESCRIPTION OF ITEMS OR MATERIALS	UNIT PRICE	AMOUNT
1		PEPSI ADD ON 2026	15000.00000	15,000.00
		ACCOUNT SUMMARY (FOR INTERNAL USE)		
		ACCOUNT NUMBER	ACCOUNT AMOUNT	
		143 E 73100 422 000 00000 000	15,000.00	
			PAGE TOTAL	15,000.00
			TOTAL	15,000.00

This is a Requisition and not an official Purchase Order.
 The District is not financially responsible for the
 unauthorized purchases made with a Requisition.

**PURCHASING DEPARTMENT
WASHINGTON COUNTY BOARD OF EDUCATION**

Purchase Order **№ 7648**
 Date Issued **3/12/20**
 Appropriation No. **141E71100449**
 Dept. **Academics**
 School **DB & EC**

PURCHASE ORDER

TO
College Board
 Deliver to **Washington County Schools**
 Address **405 W College St**
 Via **Jonesborough, TN 37659**

NOTICE TO VENDOR
 1. Purchase order **MUST** bear two signatures in order to be valid.
 2. Purchase order number **MUST** appear on all invoices submitted for payment.
 3. Mail **TWO** copies of your invoice promptly to:
**Washington County Board of Education
 405 West College Street
 Jonesborough, TN 37659
 Telephone (423) 753-1105**

Articles on this order must be charged to account of

ARTICLES OR SERVICES (Unless otherwise stated all prices F.O.B. Destination)	CODE	QUANTITY & UNIT	UNIT PRICE	TOTAL
<p align="center">PreAp Courses DB & EC</p> <p><i>CJK 3/12/20</i></p>				
GRAND TOTAL - INCLUDING ALL ATTACHED PAGES			NTE	\$20,000

SUBJECT TO THE FOLLOWING CONDITIONS

1. All packages, cartons or other containers must be plainly marked with the purchase order number.
2. The right is reserved to purchase in the open market and to charge the difference to the Vendor in the event that deliveries are not made at the time specified in the bid and on this order.
3. Whenever a delivery is rejected, the Vendor shall be notified and be given the reason for the rejection. All rejected deliveries shall be held at the Vendor's risk and he shall bear the expense of removal.
4. Acceptance of this order includes acceptance of all terms, prices, delivery, instructions, specifications and conditions stated.
5. The county is not liable for Federal excise tax or state sales tax.
6. Each shipment and/or each purchase order should be covered by separate invoice.

IMPORTANT: INVOICES AND PACKAGES MUST BEAR PURCHASE ORDER NUMBER

VENDOR'S COPY	There is an otherwise unincumbered balance to the credit of the proper appropriation, allotment or fund to meet the expenditure covered by this purchase.	APPROVED:
	Authorized Signature	

PURCHASING DEPARTMENT
WASHINGTON COUNTY BOARD OF EDUCATION

Purchase Order **№ 7548**

Date Issued **3/2/26**

Appropriation No. **141E71300730002**

Dept. **ISM**

School **OCES - Chris Tipton**

PURCHASE ORDER

TO

B + H

Deliver to **David Crockett Highschool**
 Address **684 Old St Rt 34**
 Via **Jonesborough, TN 37659**

NOTICE TO VENDOR

1. Purchase order **MUST** bear two signatures in order to be valid.
2. Purchase order number **MUST** appear on all invoices submitted for payment.
3. Mail **TWO** copies of your invoice promptly to:

Washington County Board of Education
 405 West College Street
 Jonesborough, TN 37659
 Telephone (423) 753-1105

Articles on this order must be charged to account of

ARTICLES OR SERVICES (Unless otherwise stated all prices F.O.B. Destination)	CODE	QUANTITY & UNIT	UNIT PRICE	TOTAL
<p>Wacom DTK2260 Creative Pen Display-Tablets</p> <p><i>Cyk 3-6-26</i></p> <p>*Quote attached*</p>		15	\$959	\$14,385
GRAND TOTAL - INCLUDING ALL ATTACHED PAGES				\$14,385

SUBJECT TO THE FOLLOWING CONDITIONS

1. All packages, cartons or other containers must be plainly marked with the purchase order number.
2. The right is reserved to purchase in the open market and to charge the difference to the Vendor in the event that deliveries are not made at the time specified in the bid and on this order.
3. Whenever a delivery is rejected, the Vendor shall be notified and be given the reason for the rejection. All rejected deliveries shall be held at the Vendor's risk and he shall bear the expense of removal.
4. Acceptance of this order includes acceptance of all terms, prices, delivery, instructions, specifications and conditions stated.
5. The county is not liable for Federal excise tax or state sales tax.
6. Each shipment and/or each purchase order should be covered by separate invoice.

IMPORTANT: INVOICES AND PACKAGES MUST BEAR PURCHASE ORDER NUMBER

VENDOR'S COPY

There is an otherwise unincumbered balance to the credit of the proper appropriation, allotment or fund to meet the expenditure covered by this purchase.

Authorized Signature

APPROVED:

Purchasing Agent



WASHINGTON
COUNTY SCHOOLS
INSPIRE * STRIVE * THRIVE

PRICE INQUIRY FORM

VENDOR	DESCRIPTION OF ITEM FOR PRICE COMPARISON	PRICE QUOTED
Firm <u>B&H</u> Address _____ Person Contacted _____ Date _____	<u>Wacom Tablets</u>	<u>\$14,385</u> <u>(x15)</u>
Firm <u>Best Buy</u> Address _____ Person Contacted _____ Date _____	<u>Wacom Tablets</u>	<u>\$14,999</u> <u>(x15)</u>
Firm <u>Wacom</u> Address _____ Person Contacted _____ Date _____	<u>Wacom Tablets</u>	<u>\$16,461</u> <u>(x15)</u>

Name of person obtaining inquiry Hannah Woodward



Government, Education, and Corporate Department
For Pricing Requests, Purchase Orders, and Customer Service:

Phone: **800-947-8003**
212-239-7503

Fax: **800-858-5517**
212-239-7759

Email: Education: emailbids@bhphoto.com Fed Gov: fedalsales@bhphoto.com
Corporate: corporatesales@bhphoto.com State and Local: biddept@bhphoto.com

The Professional's Source

420 Ninth Avenue, New York City, NY 10001 • www.bhphotovideo.com

Federal ID#: 13-2766071

Prices Are Valid Until: 03/29/26 Quote No.: 916277521
Reference No.: R250402

Sold To: Washington County Board Of Ed
405 W College St
Attn: Accounts Payable
JONESBOROUGH, TN 37659

Ship To: Washington County Board Of Ed
405 W College St
Attn: Accounts Payable
JONESBOROUGH, TN 37659

Bill Phone: (423)753-1105

(423)753-1105

Date	Customer Code	Terms	Salesperson	Ship Via	
02/27/26	10746371	N/A	EJW	FDX GROUND	
Line No	Qty Ord	Item Description	SKU# MFR#	Item Price	Amount
1	15	WACOM DTK2260 CINTIQ 22 CREATIVE PEN DISPLAY/REG Country of Origin: VIETNAM	WADTK2260K0A (DTK2260K0A)	959.00 Retail: 999.95 Savings: 40.95	14,385.00 Retail: 14,999.25 Savings: 614.25
Instant Savings 300.00 Exp. 03/29/26					
In Stock - while supplies last.					
PLEASE NOTE: ----- **** Please reference your quote number on all PO's **** **** ALL PRICES ARE LISTED IN USD ****					
Payment Type - NO PAYMENT TYPE SELECTED				- Amount	
				Sub-Total:	14,385.00
				Total Savings:	614.25
				Shipping:	0.00
				Total:	14,385.00

BNH_quote

C. Tipton

Best Buy > Computers & Tablets > Computer Accessories & Peripherals > Drawing Tablets

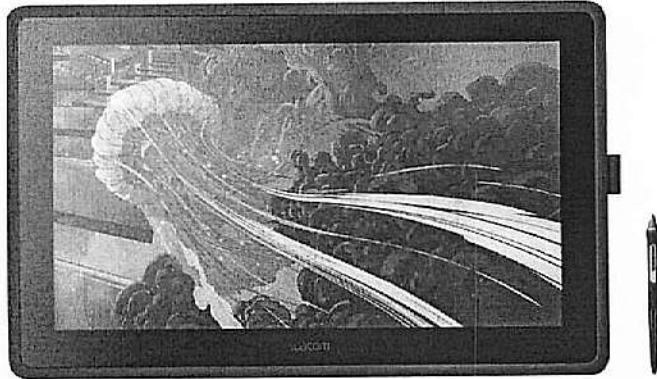

Wacom

Wacom - Cintiq 22 Pen Display Drawing Tablet - Black

Model: DK2260KDA SKU: 6361711

4.9 (17 reviews)

\$999.99

\$83.34/mo.

Save \$300
Comp. Value: \$1,299.99

or suggested payments with 12-Month Financing
Show me how

Finance Options View your offers

Special Offers On related products

Protect your tablet

What's included Terms & Conditions

Accidental Geek Squad Protection

No Plan	1-Year \$149.99 About \$12.50/mo.	2-Year \$199.99 About \$8.33/mo.	3-Year \$249.99 About \$8.33/mo.
---------	---	--	--

Specifications

Screen Size	21.5 inches
Screen Resolution	1920 x 1080
Active Area	18.7" x 10.6"
Total Storage Capacity	0 gigabytes
Battery Chemistry	Lithium-ion
Pressure Levels	8192

See All Specifications

Features

Questions & Answers (20)

From the Manufacturer

Availability

Pickup Ready on Tue, Mar 3	Shipping Get it by Sat, Feb 28
----------------------------------	--------------------------------------

Order now for pickup on Tue, Mar 3 at Nashville West

Sold by Best Buy

Add to cart Save

Return & Exchange Policy

Key Accessories:

Wacom - ExpressKey Remote - Black, Grey
\$119.95
~~\$134.95~~
Add to cart

More Buying Options

New
\$999.95 - \$1,449.00

Related Item

Sponsored
Wacom - One 14 (2025) Pen Display Drawing Tablet - White
\$299.95

[Back](#)

Shopping Cart

Item Sub-total \$14,999.25

Shopping Cart

Good choice - free shipping is now available for you.

+ [Add discount code](#)

Estimate Shipping and Tax

Enter your destination to get a shipping estimate.

Country

United States

State/Province

Tennessee

Zip/Postal Code

37659

FedEx

Ground (1-5 business days) \$0.00

Subtotal	\$19,499.25 \$14,999.25
Order Sub Total	\$16,461.68
Tax	\$1,462.43
Shipping (Ground (1-5 business days))	\$0.00
Order Total	\$16,461.68

 [Feedback](#)

Secure Checkout



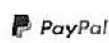

Pay later with **Klarna** [Check purchase power](#)

✓ Good choice! Here are your products:

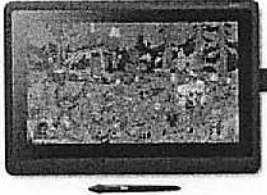
Item	Price	Qty	Total Price
	\$1,299.95 \$999.95	15	\$14,999.25

Add product protection from \$109

[Remove](#) 

[Wacom Cintiq 22 \(previous generation\)](#)

DTK2260K0A

[Remove](#) 

[Update Shopping Cart](#)

 [Feedback](#)



PURCHASING DEPARTMENT
WASHINGTON COUNTY BOARD OF EDUCATION

PURCHASE ORDER

Purchase Order **No 7018**

Date Issued **11/14/25**

Appropriation No. **72130-322**

Dept. **Academics**

School **DBDOC - CO**

TO

College Board

Deliver to **Washington County Schools**

Address **405 W College St**

Via **Jonesborough, TN 37659**

Articles on this order must be charged to account of

NOTICE TO VENDOR

1. Purchase order **MUST** bear two signatures in order to be valid.
2. Purchase order number **MUST** appear on all invoices submitted for payment.
3. Mail **TWO** copies of your invoice promptly to:

Washington County Board of Education
 405 West College Street
 Jonesborough, TN 37659
 Telephone (423) 753-1105

ARTICLES OR SERVICES	CODE	QUANTITY & UNIT	UNIT PRICE	TOTAL
(Unless otherwise stated all prices F.O.B. Destination)				
AP Exams - DBHS + DCHS				
*BOE approved 12/4/2025				
GRAND TOTAL - INCLUDING ALL ATTACHED PAGES			NTE	\$44,000

HW 3/12
\$50,200
~~**\$44,000**~~

SUBJECT TO THE FOLLOWING CONDITIONS

1. All packages, cartons or other containers must be plainly marked with the purchase order number.
2. The right is reserved to purchase in the open market and to charge the difference to the Vendor in the event that deliveries are not made at the time specified in the bid and on this order.
3. Whenever a delivery is rejected, the Vendor shall be notified and be given the reason for the rejection. All rejected deliveries shall be held at the Vendor's risk and he shall bear the expense of removal.
4. Acceptance of this order includes acceptance of all terms, prices, delivery, instructions, specifications and conditions stated.
5. The county is not liable for Federal excise tax or state sales tax.
6. Each shipment and/or each purchase order should be covered by separate invoice.

IMPORTANT: INVOICES AND PACKAGES MUST BEAR PURCHASE ORDER NUMBER

VENDOR'S COPY

There is an otherwise unincumbered balance to the credit of the proper appropriation, allotment or fund to meet the expenditure covered by this purchase.

[Signature]
 Authorized Signature

APPROVED:

[Signature]
 Purchasing Agent

Program Summary

Year	Courses	AP Students	Exams	Undecided Exams	Total Cost
2025/26	12	26	2	0	\$0
2024/25	11	178	231	0	\$18,284

[More program statistics](#)

Ship To

David Crockett High School
 684 Old State Route 34
 Jonesborough, TN 37659
[Change](#)

Orders

[View Order History](#)

Submitted 10/24

Changing your order

To add or remove exams from your order, use the links in the **All Exams** table below. Then come back here and submit your changes.

- [All Exams](#)
- [Student Labels](#)
- [Other Materials](#)
- [Score Reporting Services](#)
- [Large Volume Rebates](#)

[Download Order Details](#)

Course	Exam Date	Reduced Fee	SSD Materials	Not Taking Exam	Total Exams
AP Calculus AB	Std - Hybrid 5/11	0	0	17	0
AP English Language and Composition	Std - Digital 5/13	0	0	10	0
AP Macroeconomics	Std - Hybrid 5/08	0	0	0	1

Course	Exam Date	Reduced Fee	SSD Materials	Not Taking Exam	Total Exams
AP Physics 1	Std - Hybrid 5/06	0	0	0	1

Program Summary

Year	Courses	AP Students	Exams	Undecided Exams	Total Cost
2025/26	16	135	193	0	\$17,370
2024/25	16	205	304	1	\$25,820

[More program statistics](#)

Ship To

Daniel Boone High School
 1440 Suncrest Dr
 Johnson City, TN 37615
[Change](#)

Orders

[View Order History](#)

Submitted 10/29

Changing your order

To add or remove exams from your order, use the links in the **All Exams table** below. Then come back here and submit your changes.

- [All Exams](#)
- [Student Labels](#)
- [Other Materials](#)
- [Score Reporting Services](#)
- [Large Volume Rebates](#)

[Download Order Details](#)

Course	Exam Date	Reduced Fee	SSD Materials	Not Taking Exam	Total Exams
AP Biology	Std - Hybrid 5/04	0	0	0	19
AP Calculus AB	Std - Hybrid 5/11	0	0	0	7
AP Calculus BC	Std - Hybrid 5/11	0	0	0	11

Course	Exam Date	Reduced Fee	SSD Materials	Not Taking Exam	Total Exams
AP Drawing	See Submission Deadline	0	0	0	1
AP English Language and Composition	Std - Digital 5/13	0	0	0	59
AP English Literature and Composition	Std - Digital 5/06	0	0	0	5
AP Environmental Science	Std - Digital 5/15	0	0	0	10
AP Psychology	Std - Digital 5/12	0	0	0	1
AP United States Government and Politics	Std - Digital 5/05	0	0	0	19
AP United States History	Std - Digital 5/08	0	0	0	61

**PURCHASING DEPARTMENT
WASHINGTON COUNTY BOARD OF EDUCATION**

Purchase Order **No 7463**

Date Issued 3/11/26

Appropriation No. 141-E-71300-730-002

Dept. ISM grant

School Lamar

PURCHASE ORDER

TO The stage depot
27702 crown valley Pkwy
Suite D-4 #174
Ladera Ranch, CA 92694

Deliver to Lamar Elementary

Address 3261 Hwy 81 S
Jonesborough, TN 37659

Via Donna Widner

Articles on this order must be charged to account of

NOTICE TO VENDOR

1. Purchase order **MUST** bear two signatures in order to be valid.
2. Purchase order number **MUST** appear on all invoices submitted for payment.
3. Mail **TWO** copies of your invoice promptly to:

Washington County Board of Education
405 West College Street
Jonesborough, TN 37659
Telephone (423) 753-1105

ARTICLES OR SERVICES	CODE	QUANTITY & UNIT	UNIT PRICE	TOTAL
(Unless otherwise stated all prices F.O.B. Destination)				
16' X 24' X 16" Easy-lite stage system see attached quote				
*price inquiry attached				
GRAND TOTAL - INCLUDING ALL ATTACHED PAGES				\$24,999.99

SUBJECT TO THE FOLLOWING CONDITIONS

1. All packages, cartons or other containers must be plainly marked with the purchase order number.
2. The right is reserved to purchase in the open market and to charge the difference to the Vendor in the event that deliveries are not made at the time specified in the bid and on this order.
3. Whenever a delivery is rejected, the Vendor shall be notified and be given the reason for the rejection. All rejected deliveries shall be held at the Vendor's risk and he shall bear the expense of removal.
4. Acceptance of this order includes acceptance of all terms, prices, delivery, instructions, specifications and conditions stated.
5. The county is not liable for Federal excise tax or state sales tax.
6. Each shipment and/or each purchase order should be covered by separate invoice.

IMPORTANT: INVOICES AND PACKAGES MUST BEAR PURCHASE ORDER NUMBER

VENDOR'S COPY	There is an otherwise unincumbered balance to the credit of the proper appropriation, allotment or fund to meet the expenditure covered by this purchase.	APPROVED:
	Authorized Signature	



PRICE INQUIRY FORM

VENDOR	DESCRIPTION OF ITEM FOR PRICE COMPARISON	PRICE QUOTED
Firm - <u>The Stage Depot</u> Address- <u>27702 Crown Valley Pkwy Suite D4 #174 Ladera Ranch, CA 92694</u> Person: <u>orders@thestagedepot.com</u> Date - <u>3/10/26</u>	Stage System with risers, guard rails, skirts, ADA ramp, and cart	Total: \$24,999.99
Firm: <u>Live Tour Tech LLC</u> Address: <u>3223 W 6th St. Suite 101 #1153 Los Angeles, CA 90020</u> Person- _____ Date - <u>3/9/25</u>	Stage System, stair with handrails, guard rails, cart system, ADA ramp	Total: \$25,305.00
Firm - <u>Ambrosound</u> Address: <u>835 Spring St. Erwin, TN 37650</u> Person- _____ Date - <u>2/18/25</u>	Staging Package, stage decks, steps, rails, step rails, trolley, skirt, tier ramp	Total: \$30,074.78

Name of person obtaining inquiry - Kelli Hauldren

THE STAGE DEPOT

27702 Crown Valley PKWY
 Suite D-4 # 174
 Ladera Ranch, CA 92694
 877-884-3426
 www.thestagedepot.com

Estimate

Date	Estimate #
3/10/2026	20522C

Name / Address
Donna Widner 4237531100 widnerd@wcde.org

Project

Item	Description	Qty	U/M	Rate	Total
ISTAGE122416	16' x 24' x 16" Easy-Lite Stage System (24 pcs of 4x4 platforms w/ 16" High Risers)-Black Carpet				
ISTAGE122416	16" HIGH COMPLETE STAGE SYSTEM(18 PCS. OF MATCHING RISERS	1	ea	7,812.00	7,812.00T
ISTAGE12816	16" HIGH COMPLETE STAGE SYSTEM (6 PCS. OF 16" MATCHING RISERS)	1	ea	2,604.00	2,604.00T
IS4STEP16C	4' WIDE STEP PACKAGE FOR 16" HIGH STAGES CARPETED	2	ea	308.00	616.00T
ISSTEPGRPD	Two pack of step guard rail panels w/ mounting hardware	4	ea	244.00	976.00T
IS4X4GRPD	Two Pack of guard rail panels with chair stops for 4' x 4' platforms w/ mounting hardware	5	ea	520.00	2,600.00T
IS2CMB	PACK OF GUARD RAIL CORNER MOUNTING HARDWARE (2 PCS PER PACK)	2	ea	31.00	62.00T
SDSK8X16	8' WIDE 16" LONG BLACK SKIRT	7	ea	95.00	665.00T
ISCART	Platform & Riser Cart - Transports up to 10 Platforms and 10 Risers - Fits through Standard Doors	3	ea	925.00	2,775.00T
DISCOUNT	Discount for School			-1,810.01	-1,810.01

Subtotal

Sales Tax (0.0%)

Total

Voted #1 in Customer Service!

The Stage Depot

America's Portable Staging Authority

orders@thestagedepot.com

THE STAGE DEPOT

27702 Crown Valley PKWY
 Suite D-4 # 174
 Ladera Ranch, CA 92694
 877-884-3426
www.thestagedepot.com

Estimate

Date	Estimate #
3/10/2026	20522C

Name / Address
Donna Widner 4237531100 widnerd@wcde.org

Project

Item	Description	Qty	U/M	Rate	Total
ADA16S	16" High ADA Ramp, Straight, No Landing	1	ea	8,700.00	8,700.00T
Free Shipping	Free Shipping-within the United States (Excludes AK,HI, Canada & rural areas)			0.00	0.00T

Subtotal				\$24,999.99
Sales Tax (0.0%)				\$0.00
Total				\$24,999.99

Voted #1 in Customer Service!
The Stage Depot

America's Portable Staging Authority

orders@thestagedepot.com

QUOTE

Live Tour Tech LLC

3223West6thStreet,Suite101 #1153 Los Angeles, CA 90020 United States
818-495-5293

BILL TO
widnerd@wcde.org

QUOTE # 562B
QUOTE DATE 03/09/2026

DESCRIPTION	AMOUNT
Recommended Con)guration	25,305.00

24'x16'PortableModularAluminum Stage
16" Height

This layout builds cleanly using our 4' x 4' modular system.

Footprint: 384 sq ft
Deck Count: (24) 4' x 4' sections

What's Included

- (24)Reinforced4'x4'AluminumStage Decks
- 16" Leg System
- ReinforcedInterlockingSide-Frame System (prevents ?ex or wobble)
- ProfessionalNon-SlipPerformance Surface
- (2) Stair Units with Handrails
- BlackStageSkirtingforFrontandSides
- Guardrails for Back and Sides
- Step Railings
- Storage Cart System
- 100%Tool-FreeAssembly(nobolts, no wrenches)
- Rust-ProofAluminumConstruction (indoor/outdoor rated)
- All Required Hardware
- Freight Shipping Included

ADA Ramp Option

Yes—ADA-compliant ramps are possible.

At 16" stage height, the minimum ADA ramp length is typically 16' to maintain a 1:12 slope. ADA ramps would also include the proper

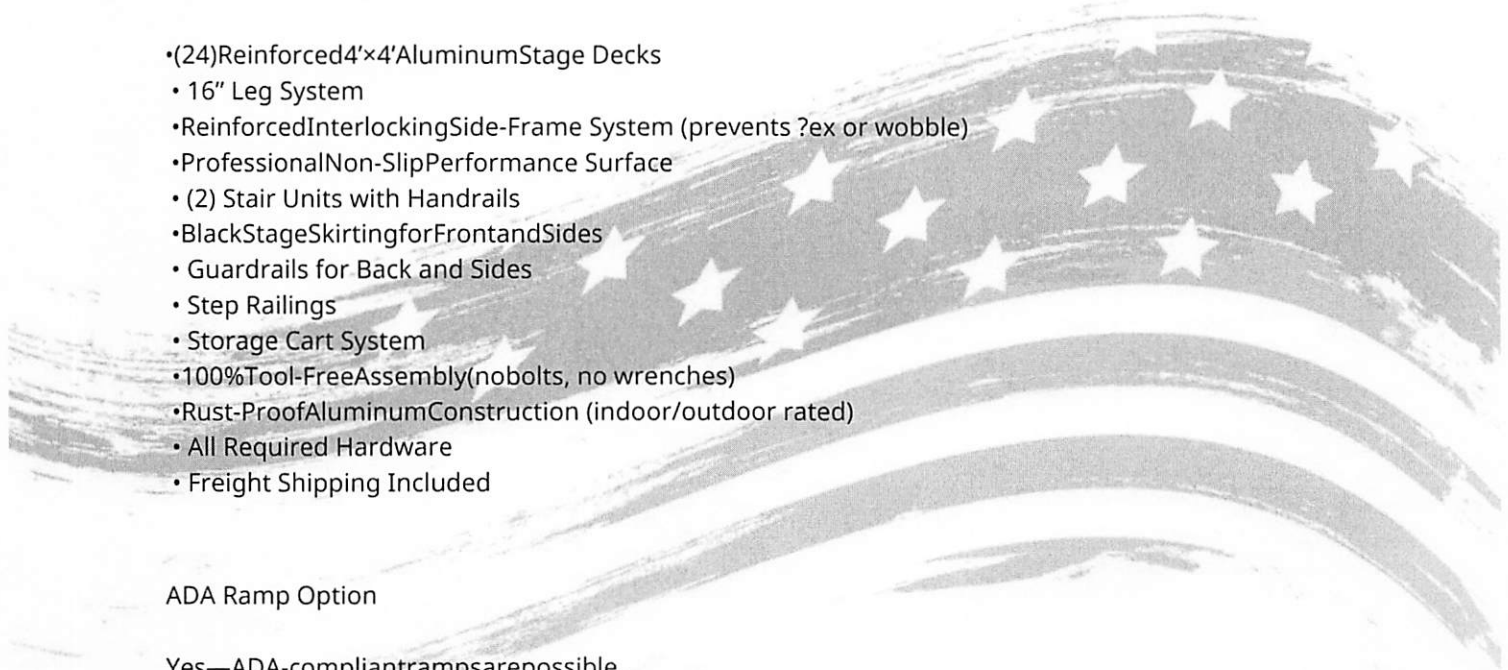

handrails.

I can quote that separately depending on how you want the access laid out.

Built for School & Event Use

Most cheaper stages are basic 4-leg platforms that shift over time. Our reinforced interlocking frame locks the full platform together so it stays solid and quiet during use.

The decks are lightweight, tool-free, and stack ?at for storage, while the cart system keeps transport and organization much cleaner.

Investment

Stage System: \$14,856

Stair Units (2): \$0 Included/No Charge

Stage Skirting: \$384

Guardrail Package (12) 4x3 (sides and back) \$2,220

Storage Cart System (4) Up to 6 decks per cart: \$996

ADA Ramp 16": \$6,849

Freight: Included

TOTAL

\$25,305.00

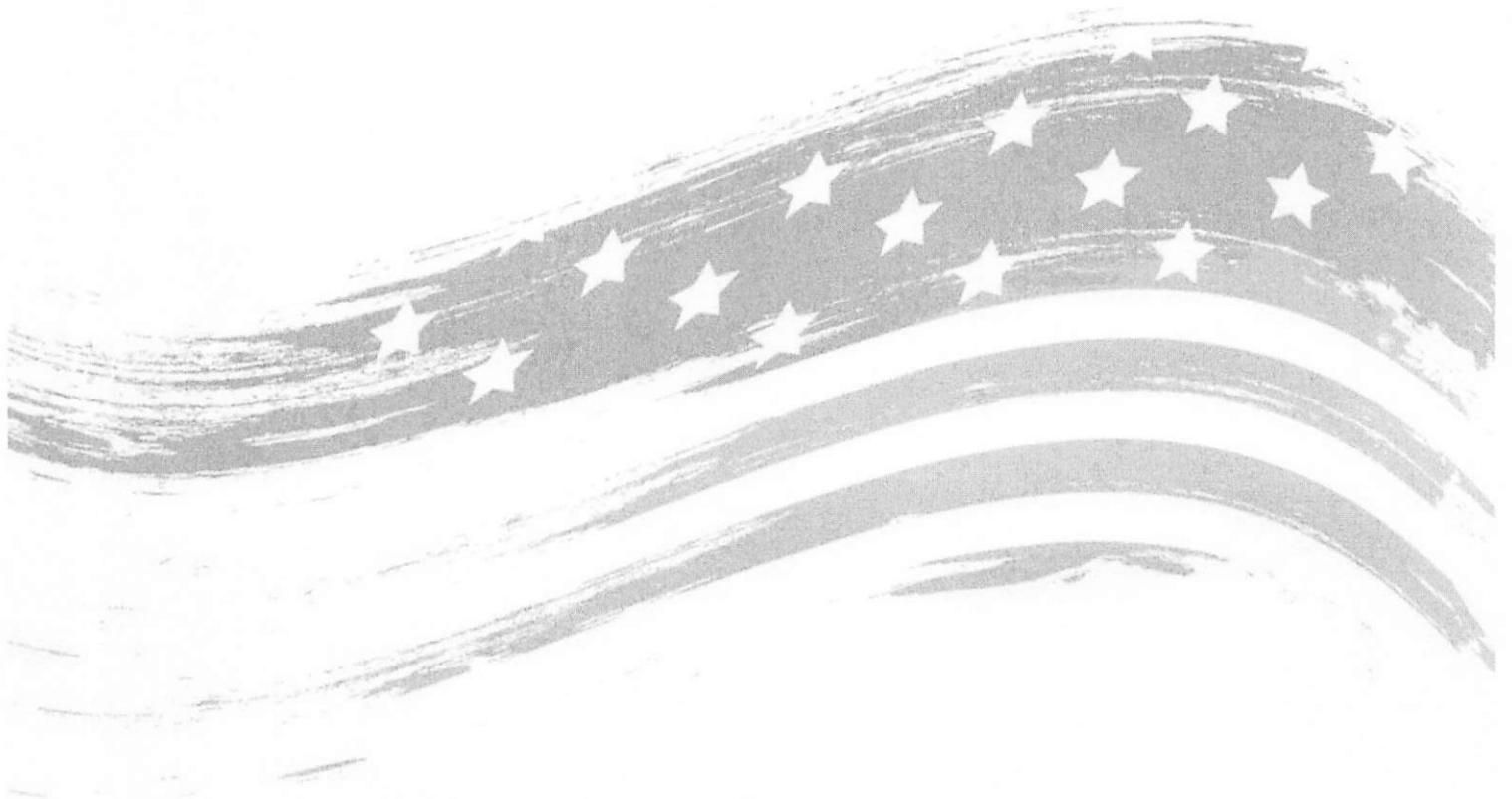

What Sets Our Staging Apart?

Aluminum Body

- **High Grade Aluminum** Build
- No corrosion, no decay
- Long-term durability
- Maintains structural strength year after year

Tool - Free

- No tools. No bolts. **No stress.**
- **EASY setup and teardown**
- One-person deck handling
- Set up in minutes

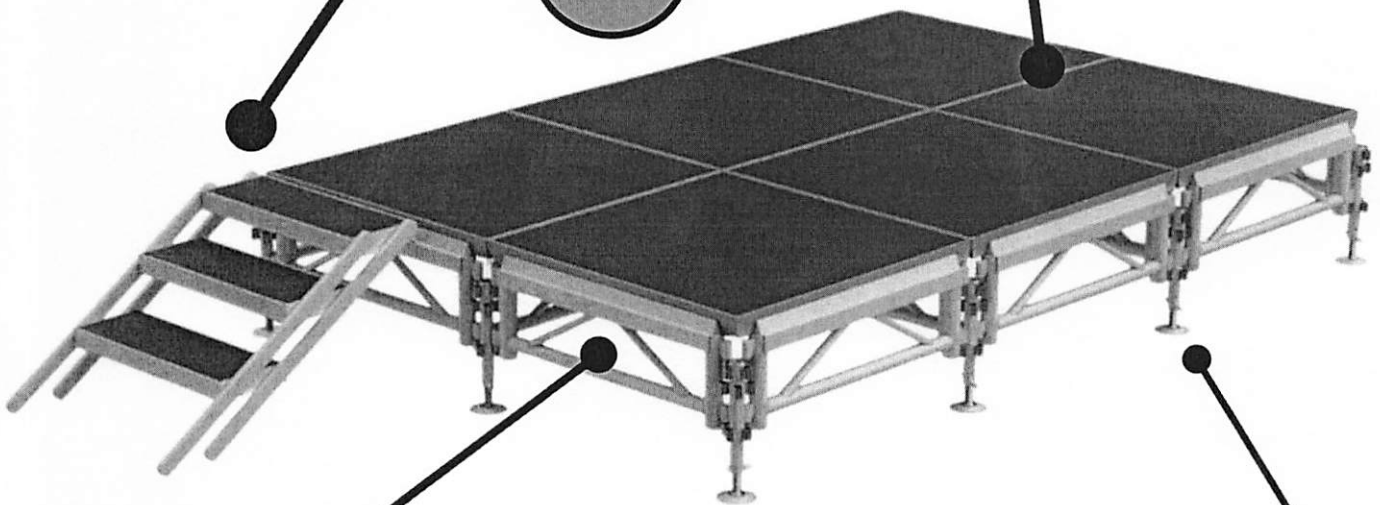

Reinforced Sides

- **Extra** Stability
- Built for **repeated** use
- Reduces vibration and movement

Adjustable Legs

- No wobble on **slopes, rough, or uneven surfaces**
- Level stage every time



What about other stages?



Cheaper, 4-Legged Stages

- Often requires **crawling underneath the stage to secure bolts**
- Tool-based setup can be **slower and more complex**
- Lightweight frames
- Fixed-height legs can be **unstable on grass, slopes, or uneven ground**
- Metal components may corrode over time depending on material and environment
- Joints and bolts can loosen with repeated use
- Can feel temporary or less stable
- **Past clients often report these setups as labor-intensive**



Thin Accordion Style Stages

- Designed with slim, lightweight leg structures
- Lower upfront cost, but can be challenging long-term
- **Often unsuitable for uneven surfaces**
- Limited individual leg adjustment compared to modular systems when used on uneven terrain
- Typically selected for lighter-duty or occasional use

It's Easy as 1, 2, 3!

1. Place the 4 adjustable legs on the ground

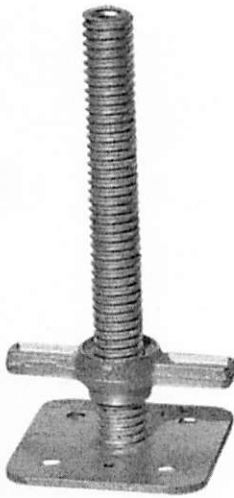

2. Slide in the pillars and four reinforced sides

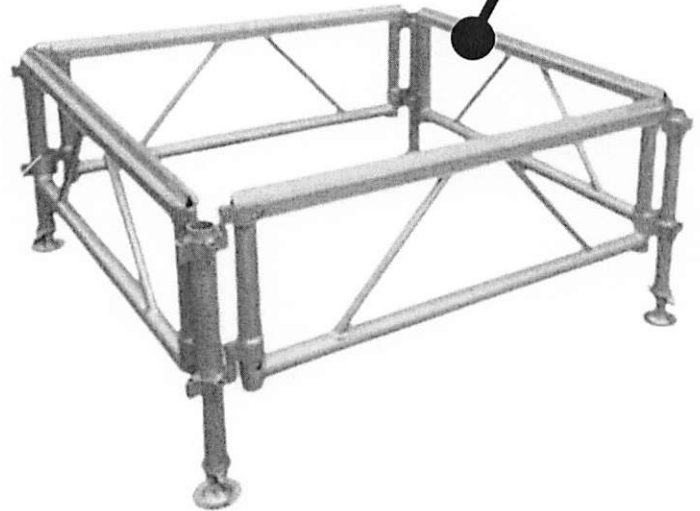

3. Slap on the Top Deck!



You're Done!

The Staging Numbers



Ambrosound
835 Spring Street
Erwin, TN 37650
+14239140571
ambrosound@gmail.com

Estimate

ADDRESS

Lamar School

ESTIMATE #	DATE
1615	02/18/2026

PRODUCT	QTY	RATE	AMOUNT
STAGING PACKAGE			
Pro Flex 24' x 16' Portable Stage 4'x4' Stage Decks with 16"-24" adjustable legs	22	744.40	16,376.80
Pro Flex Deck Clamps	22	17.00	374.00
Pro Flex Leg Clamps	22	23.00	506.00
Pro Flex Steps (1 set)	1	710.00	710.00
Pro Flex 8' rails (3)	3	345.00	1,035.00
Pro Flex 4' rails (6)	6	329.00	1,974.00
Pro Flex Step rails (2)	2	210.00	420.00
Pro Flex Trolley (carries 22 decks)	1	1,039.00	1,039.00
Ameristage Stage Skirts (package to fit 3 sides)	1	439.98	439.98
ADA Compliant 24" Rise Multi Tier Ramp	2	3,600.00	7,200.00
		TOTAL	\$30,074.78

Accepted By

Accepted Date

The Lighting Numbers



Ambrosound
835 Spring Street
Erwin, TN 37650
+14239140571
ambrosound@gmail.com

Estimate

ADDRESS
Lamar School

ESTIMATE #	DATE
1613	02/18/2026

PRODUCT	QTY	RATE	AMOUNT
LIGHTING SYSTEM (SECOND REVISION)			
Chauvet Slimpar DMX Lighting Fixtures	10	399.99	3,999.90
Chauvet Obey 70 Lighting Controller	1	265.00	265.00
20' Theatre Ladder Bar and Rigging Package	1	312.00	312.00
Chauvet Lighting Clamps	10	22.00	220.00
Safety Cables	10	7.78	77.80
DMX Cable/Connectors	1	156.50	156.50
Ambrosound Installation	1	1,100.00	1,100.00
TOTAL			\$6,131.20

Accepted By

Accepted Date

Staging Highlights

Pro Flex Stage Decking

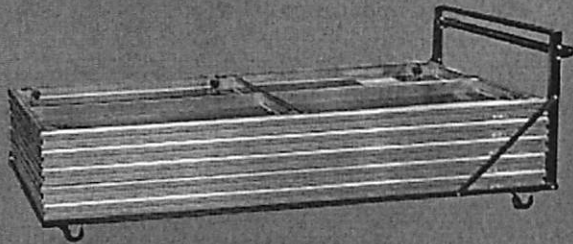
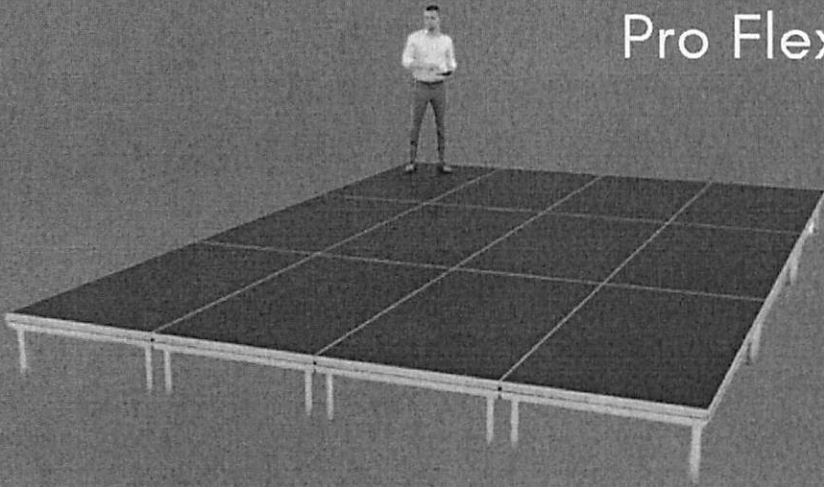

Pro Flex Stage Deck Cart

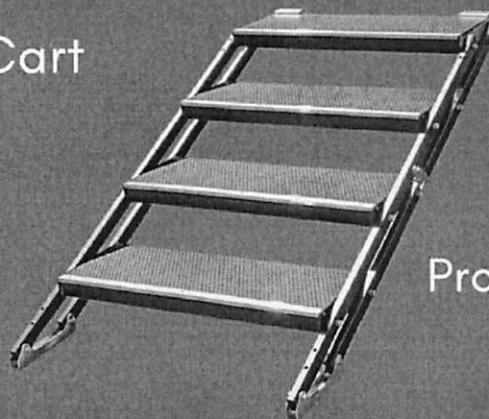

Pro Flex Stage Steps

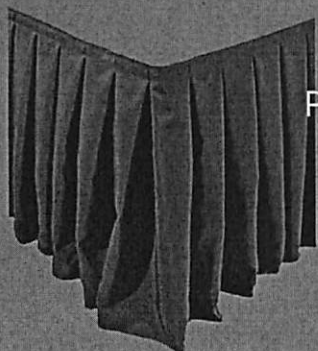

Pro Flex Stage Skirt Package

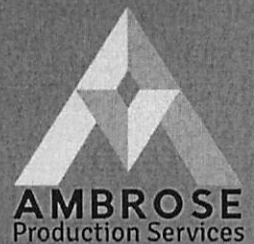

AMBROSE
Production Services

Lighting Highlights

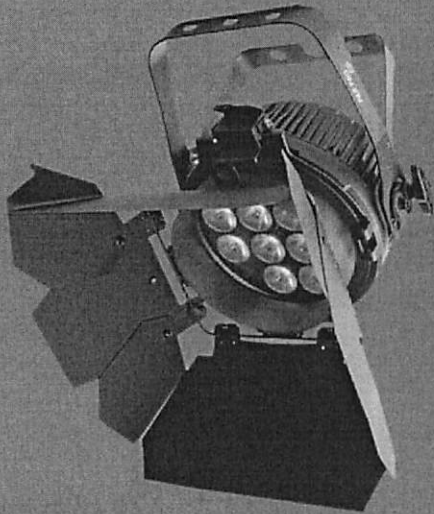

Chauvet Slimpar Pro Q LED
Wash Stage Lights

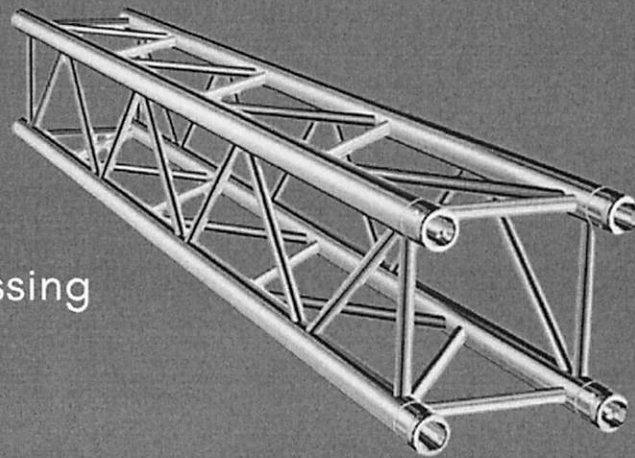

Global Trussing

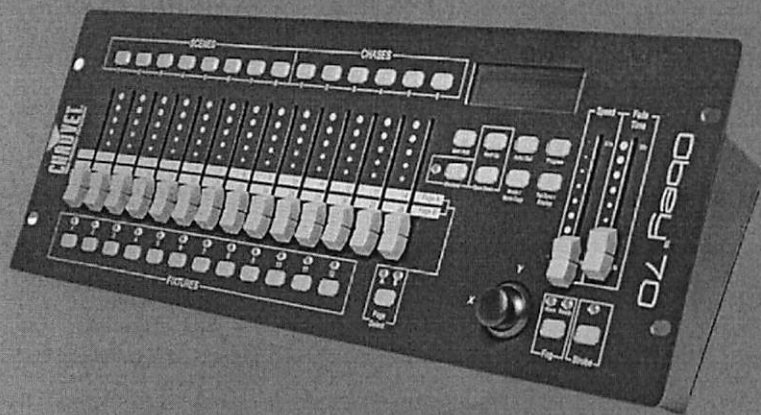

Chauvet Obey 70 Lighting
Controller

PURCHASING DEPARTMENT
WASHINGTON COUNTY BOARD OF EDUCATION

Purchase Order No **7577**

Date Issued **3/24/26**

Appropriation No. **141E72710-729**

Dept. **Maintenance**

School

PURCHASE ORDER

TO **Leonard Truck Outfitters**
3925 Bristol Hwy
Johnson City, TN 37601

Deliver to **Washington County Schools**

Address

Via

Articles on this order must be charged to account of

NOTICE TO VENDOR

1. Purchase order **MUST** bear two signatures in order to be valid.
2. Purchase order number **MUST** appear on all invoices submitted for payment.
3. Mail **TWO** copies of your invoice promptly to:

Washington County Board of Education
 405 West College Street
 Jonesborough, TN 37659
 Telephone (423) 753-1105

ARTICLES OR SERVICES	CODE	QUANTITY & UNIT	UNIT PRICE	TOTAL
(Unless otherwise stated all prices F.O.B. Destination)				
Shelving Kits & Ladder Rack for 2 Vans w/ Installation				12,805⁰⁰
				11,373⁰⁰
GRAND TOTAL - INCLUDING ALL ATTACHED PAGES				24,178⁰⁰

SUBJECT TO THE FOLLOWING CONDITIONS

1. All packages, cartons or other containers must be plainly marked with the purchase order number.
2. The right is reserved to purchase in the open market and to charge the difference to the Vendor in the event that deliveries are not made at the time specified in the bid and on this order.
3. Whenever a delivery is rejected, the Vendor shall be notified and be given the reason for the rejection. All rejected deliveries shall be held at the Vendor's risk and he shall bear the expense of removal.
4. Acceptance of this order includes acceptance of all terms, prices, delivery, instructions, specifications and conditions stated.
5. The county is not liable for Federal excise tax or state sales tax.
6. Each shipment and/or each purchase order should be covered by separate invoice.

IMPORTANT: INVOICES AND PACKAGES MUST BEAR PURCHASE ORDER NUMBER

VENDOR'S COPY

There is an otherwise unincumbered balance to the credit of the proper appropriation, allotment or fund to meet the expenditure covered by this purchase.

Authorized Signature

APPROVED:

Purchasing Agent

PRIC
Washin

14/E 72710-229

Vendor	Description	Price Quoted
Firm <u>American VAN</u> Address <u>149 Lehigh Ave</u> <u>LAKewood NJ 08701</u> Person Contacted <u>Online</u> Date <u>3/17/26</u>	Shelung k for 2 NO FASTA	14,959.19 + LWB 13,670.43 SWB <hr/> 28,654.62
Firm <u>Elite Truck</u> Address <u>305 N MARKET ST</u> <u>WASHYNGTON, NC 27885</u> Person Contacted <u>Online</u> Date <u>3/17/26</u>		16,975.23 LWB + 12,882.14 SWB <hr/> 29,857.37
Firm <u>Leonard Truck</u> Address <u>3975 Bristol Hwy</u> <u>Jackson, TN 37601</u> Person Contacted <u>Mike</u> Date <u>3/17/26</u>	Shelung kits + Ladder rack for 2 VANS w/ installation	12,805.00 LWB + 11,373.00 <hr/> 24,178.00

Jeremy Moore

Name of person obtaining inquiry

Quote

Quote expires
May 16, 2026

* Page 2 of 2



Leonard Aluminum Utility Buildings, LLC
T/A Leonard Buildings & Truck Accessories
3925 BRISTOL HWY
Johnson City, TN 37601
Phone: 423.282.8617
<http://www.leonardusa.com>
pos544@leonardusa.com

HVAC
VAN

Ticket #: 544-QUO-106836
Ticket Date: 3/17/26
Station: ECOM

Sold to: WASHINGTON COUNTY DEPT EDUCATION
405 W COLLEGE ST
JONESBOROUGH, TN 37659
none@none.com

Ship to:

Customer #: 544-106607
Sales Rep: OWE005

Ship date:
Location: 544

Ship-via code:
Terms: Net 30 days

Quantity	Item #	Description	List price	Discount	Savings	Price	Ext Price
1	RAK-2291301	EZ GLIDE2 EXT DROP MID/HIGH VN	\$2,483.99	\$-371.99	\$-371.99	\$2,112.00	2,112.00
18	SER-LABOR	Installation Fee				\$75.00	1,350.00
1	ITEM-NOTE	HVAC PACKAGE				\$0.00	0.00

User: OWE005

Total line items: 15

Sale subtotal: 12,805.00

Sales Tax 0.00

Total: 12,805.00

Thank You For Your Business!
You Saved \$1,482.76

Terms & Conditions:

Trailers are not returnable at any time. Items not in new or resalable condition are not returnable at any time.
Special order items, custom painted items, installed items, items sold as is, discontinued or clearance items are not returnable at any time.
Merchandise will not be accepted for return after 30 days of our invoice date. All returned items must be in original condition and packaging.
You will be charged \$20 or 20% restocking fee, whichever is greater on return of non-defective items.
Special Orders cancelled while in progress shall incur a charge for the pro-rated portion of the cost of the item in production -not less than 25% of the quoted price.
If you paid by cash or check - your refund, less fee charges, will be mailed from the corporate office within 7 days of refund request approval.
If you paid by credit card - the credit card used for your payment will be credited, less fee charges, within 7 days of refund request approval.

Customer signature accepts the above terms and conditions.



Quote

Quote expires
May 16, 2026

* Page 1 of 2



Leonard Aluminum Utility Buildings, LLC
T/A Leonard Buildings & Truck Accessories

3925 BRISTOL HWY
Johnson City, TN 37601
Phone: 423.282.8617
<http://www.leonardusa.com>
pos544@leonardusa.com

Ticket #: 544-QUO-106836
Ticket Date: 3/17/26
Station: ECOM

Sold to: WASHINGTON COUNTY DEPT EDUCATION
405 W COLLEGE ST
JONESBOROUGH, TN 37659
none@none.com

Ship to:

Customer #: 544-106607
Sales Rep: OWE005

Ship date:
Location: 544

Ship-via code:
Terms: Net 30 days

Quantity	Item #	Description	List price	Discount	Savings	Price	Ext Price
5	RAK-9909302	PARTS CAB 9 BIN 16"/12"/12"	\$456.99	\$-68.99	\$-344.95	\$388.00	1,940.00
2	RAK-9864301	REFRIGERANT TANK RACK 4 X 30#	\$583.99	\$-0.99	\$-1.98	\$583.00	1,166.00
1	RAK-9912302	2 DRAWER UNIT 16"x14"x12"	\$471.99	\$-70.99	\$-70.99	\$401.00	401.00
2	RAK-9365303	52"L X 60"H X 16"D 4 SHELF UNI	\$793.99	\$-118.99	\$-237.98	\$675.00	1,350.00
2	RAK-9344303	42" X 44" X 16" 3-SHELF UNIT	\$599.99	\$-90.99	\$-181.98	\$509.00	1,018.00
4	RAK-9604301	42" X 12" ACCESSORY BACK PANEL	\$114.99	\$-2.99	\$-11.96	\$112.00	448.00
2	RAK-9504301	42" WIDE DOOR				\$250.00	500.00
4	RAK-9605301	52" ACCESSORY BACK PANEL	\$118.99	\$-4.99	\$-19.96	\$114.00	456.00
1	RAK-96310301	FORD TRANSIT MID ROOF MAX/CAB	\$1,550.99	\$-234.99	\$-234.99	\$1,316.00	1,316.00
1	RAK-96906301	MAX/CAB WINDOW	\$175.99	\$-0.99	\$-0.99	\$175.00	175.00
1	RAK-975104301	VAN SHELF NO DRILL MOUNT KIT	\$329.99	\$-4.99	\$-4.99	\$325.00	325.00
1	RAK-2102001	102" TRANSIT MOUNT CHANNEL KIT				\$248.00	248.00

Terms & Conditions:

Trailers are not returnable at any time. Items not in new or resalable condition are not returnable at any time.

Special order items, custom painted items, installed items, items sold as is, discontinued or clearance items are not returnable at any time.

Merchandise will not be accepted for return after 30 days of our invoice date. All returned items must be in original condition and packaging.

You will be charged \$20 or 20% restocking fee, whichever is greater on return of non-defective items.

Special Orders cancelled while in progress shall incur a charge for the pro-rated portion of the cost of the item in production -not less than 25% of the quoted price.

If you paid by cash or check - your refund, less fee charges, will be mailed from the corporate office within 7 days of refund request approval.

If you paid by credit card - the credit card used for your payment will be credited, less fee charges, within 7 days of refund request approval.

Customer signature accepts the above terms and conditions.



Quote

Quote expires
May 16, 2026

* Page 2 of 2



Leonard Aluminum Utility Buildings, LLC
T/A Leonard Buildings & Truck Accessories
3925 BRISTOL HWY
Johnson City, TN 37601
Phone: 423.282.8617
<http://www.leonardusa.com>
pos544@leonardusa.com

Ticket #: 544-QUO-106836
Ticket Date: 3/17/26
Station: ECOM

Sold to: WASHINGTON COUNTY DEPT EDUCATION
405 W COLLEGE ST
JONESBOROUGH, TN 37659
none@none.com

Ship to:

Customer #: 544-106607
Sales Rep: OWE005

Ship date:
Location: 544

Ship-via code:
Terms: Net 30 days

Quantity	Item #	Description	List price	Discount	Savings	Price	Ext Price
1	RAK-2291301	EZ GLIDE2 EXT DROP MID/HIGH VN	\$2,483.99	\$-371.99	\$-371.99	\$2,112.00	2,112.00
18	SER-LABOR	Installation Fee				\$75.00	1,350.00
1	ITEM-NOTE	HVAC PACKAGE				\$0.00	0.00

User: OWE005

Total line items: 15

Sale subtotal: 12,805.00

Sales Tax 0.00

Total: 12,805.00

Thank You For Your Business!
You Saved \$1,482.76

Terms & Conditions:

Trailers are not returnable at any time. Items not in new or resalable condition are not returnable at any time.

Special order items, custom painted items, installed items, items sold as is, discontinued or clearance items are not returnable at any time.

Merchandise will not be accepted for return after 30 days of our invoice date. All returned items must be in original condition and packaging.

You will be charged \$20 or 20% restocking fee, whichever is greater on return of non-defective items.

Special Orders cancelled while in progress shall incur a charge for the pro-rated portion of the cost of the item in production -not less than 25% of the quoted price.

If you paid by cash or check - your refund, less fee charges, will be mailed from the corporate office within 7 days of refund request approval.

If you paid by credit card - the credit card used for your payment will be credited, less fee charges, within 7 days of refund request approval.

Customer signature accepts the above terms and conditions.



New
HVAC
Quot

Quote

Quote expires
May 16, 2026

* Page 1 of 2



Leonard Aluminum Utility Buildings, LLC
T/A Leonard Buildings & Truck Accessories
3925 BRISTOL HWY
Johnson City, TN 37601
Phone: 423.282.8617
http://www.leonardusa.com
pos544@leonardusa.com

Ticket #: 544-QUO-106836
Ticket Date: 3/17/26
Station: ECOM

Sold to: WASHINGTON COUNTY DEPT EDUCATION
405 W COLLEGE ST
JONESBOROUGH, TN 37659
none@none.com

Ship to:

Customer #: 544-106607
Sales Rep: OWEO05

Ship date:
Location: 544

Ship-via code:
Terms: Net 30 days

Quantity	Item #	Description	List price	Discount	Savings	Price	Ext Price
5	RAK-9909302	PARTS CAB 9 BIN 16"/12"/12"	\$456.99	\$-68.99	\$-344.95	\$388.00	1,940.00
2	RAK-9864301	REFRIGERANT TANK RACK 4 X 30#	\$583.99	\$-0.99	\$-1.98	\$583.00	1,166.00
1	RAK-9912302	2 DRAWER UNIT 16"x14"x12"	\$471.99	\$-70.99	\$-70.99	\$401.00	401.00
2	RAK-9365303	52"L X 60"H X 16"D 4 SHELF UNI	\$793.99	\$-118.99	\$-237.98	\$675.00	1,350.00
2	RAK-9344303	42" X 44" X 16" 3-SHELF UNIT	\$599.99	\$-90.99	\$-181.98	\$509.00	1,018.00
4	RAK-9604301	42" X 12" ACCESSORY BACK PANEL	\$114.99	\$-2.99	\$-11.96	\$112.00	448.00
2	RAK-9504301	42" WIDE DOOR				\$250.00	500.00
4	RAK-9605301	52" ACCESSORY BACK PANEL	\$118.99	\$-4.99	\$-19.96	\$114.00	456.00
1	RAK-96310301	FORD TRANSIT MID ROOF MAX/CAB	\$1,550.99	\$-234.99	\$-234.99	\$1,316.00	1,316.00
1	RAK-96906301	MAX/CAB WINDOW	\$175.99	\$-0.99	\$-0.99	\$175.00	175.00
1	RAK-975104301	VAN SHELF NO DRILL MOUNT KIT	\$329.99	\$-4.99	\$-4.99	\$325.00	325.00
1	RAK-2102001	102" TRANSIT MOUNT CHANNEL KIT				\$248.00	248.00

Terms & Conditions:

Trailers are not returnable at any time. Items not in new or resalable condition are not returnable at any time.
Special order items, custom painted items, installed items, items sold as is, discontinued or clearance items are not returnable at any time.
Merchandise will not be accepted for return after 30 days of our invoice date. All returned items must be in original condition and packaging.
You will be charged \$20 or 20% restocking fee, whichever is greater on return of non-defective items.
Special Orders cancelled while in progress shall incur a charge for the pro-rated portion of the cost of the item in production -not less than 25% of the quoted price.
If you paid by cash or check - your refund, less fee charges, will be mailed from the corporate office within 7 days of refund request approval.
If you paid by credit card - the credit card used for your payment will be credited, less fee charges, within 7 days of refund request approval.

Customer signature accepts the above terms and conditions.





HVAC VAN

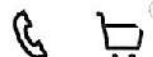

What are you looking for?



Sign In

Your cart

Subtotal

~~\$2,649.24~~

Check out

Total is \$16,975.23 pg.3



Holman Drop Down Ladder Rack Kit Double Ford Transit Connect Model 4TCSDD

Price ~~\$3,211.20~~-\$2,649.24

Estimated Delivery : Mar 19 - Mar 23

Quantity

-	1	+
---	---	---

\$2,649.24

x



Ranger Design Refrigerant Rack for HVAC Vans - 60"W w/ Straps Model 6035

Price ~~\$512.00~~-\$460.80

Estimated Delivery : Mar 24 - Mar 31

Quantity

-	1	+
---	---	---

\$460.80

x



Weather Guard HVAC/Mechanical Van Package High-Roof Ford Transit 148" WB Model 600-8413L

Price ~~\$6,411.47~~-\$5,342.89

Estimated Delivery : Mar 18 - Mar 23





Quantity

-	1	+
---	---	---

\$5,342.89 ×



Ranger Design Aluminum Contoured Partition for Ford Transit Low Roof 130" & 148" Wheelbase - Polycarbonate Window Model 3020-FTL

Price ~~\$1,576.00~~-\$1,418.40
Estimated Delivery : Mar 24 - Mar 31

Quantity

-	1	+
---	---	---

\$1,418.40 ×



Holman Drop Down Ladder Rack Kit Double 2015 - 2025 Ford Transit High Roof Model 4THSDD

Price ~~\$4,834.80~~-\$3,988.71
Estimated Delivery : Mar 16 - Mar 18

Quantity

-	1	+
---	---	---

\$3,988.71 ×



Weather Guard Rigid Flooring with Sills Ford Transit 148" Extended Wheelbase Model RFFT48E-5-01

Price ~~\$1,759.20~~-\$1,466.00
Estimated Delivery : Mar 13 - Mar 18

Quantity

-	1	+
---	---	---

~~Elite~~ mobile phone (optional)



Order summary ▾

This Includes Shipping -> **\$16,975.23**



Express checkout



Show more options ▾

OR

Contact

[Log in](#)

bella@wcde.org

Email me with news and offers

Delivery

Country/Region
United States ▾

Andrew

Bell



Company (optional)

306 1/2 forest dr



Apartment, suite, etc. (optional)

jonesborough

State
Tennessee



37659

Phone



Shipping method

Discounted Shipping -

\$233.68

Payment

All transactions are secure and encrypted.

Credit card

VISA



AMEX

+5

Card number



Expiration date (MM / YY)

Security code



Name on card
Andrew Bell



Exclusive offer : Subscribe to our "NEWSLETTER" to get a 5% OFF coupon. [Click Here \(https://www.americanvan.com/subscribe-newsletter\)](https://www.americanvan.com/subscribe-newsletter)



HVAC VAN

A Clarence Technologies Company

Shop (<https://www.americanvan.com/>)

6

Search entire store here...

SHOPPING CART



Composite Partition w/ Window, Transit Mid Roof

Model LIN-343

Price \$1,087.20

Qty

Subtotal \$1,087.20



Transit 148"WB Ext. High Roof HVAC Van Package, Steel Shelving - SAVE \$250!
(<https://www.americanvan.com/transit-steel-hvac-package-extended-high-148.html>)

(<https://www>) Model VPFT-600

Price \$6,299.00

steel-

Qty

hvac-

package- Subtotal \$6,299.00



Ford Transit, Mid & High Roof, Side Access Rotation Ladder Rack, All Wheelbases - Curb and Street Side
(<https://www.americanvan.com/dodge-ram-promaster-side-access-rotation-ladder-rack-curb-side-only-av-hrr-vrr-ft-3671.html>)

(<https://www>) Model RR-FT-72-M

Price \$3,403.34

ram-

Qty

promaster-

Subtotal \$3,403.34

side-

access-

otation-

★ REVIEWS



StabiliGrip Floor - Transit 148"WB ext. (<https://www.americanvan.com/ford-transit-148-ext-stabiligrip-without-sills.html>)

Model 752-135-6441

(<https://www>

Price \$1,459.00

[transit-](#)

Qty

[148-ext-](#)

Subtotal \$1,459.00

[stabiligrip-](#)



Refrigerant Tank Rack Tower, 2-30lb, 2-50lb, 15 1/4"W x 48 3/4"H x 13 1/4"D
(<https://www.americanvan.com/freon-tank-tower.html>)

Model FT-23050

(<https://www>Price \$445.50

[tank-](#)

Qty

[tower.html](#)). Subtotal \$891.00



[CONTINUE SHOPPING \(HTTPS://WWW.AMERICANVAN.COM/\)](https://www.americanvan.com/)

[UPDATE SHOPPING CART](#)

SUMMARY

Subtotal \$13,139.54

Tax \$1,229.30

ORDER TOTAL \$14,954.19

[APPLY DISCOUNT CODE](#)

[PROCEED TO SECURE CHECKOUT](#)

- OR -

Check out with **PayPal**

- OR -

PayPal CREDIT

★ REVIEWS

SIGN UP FOR NEWSLETTER

For News, Emails And Exclusive Offers

Your email address



FOLLOW US ON

[f_\(https://www.facebook.com/AmericanVanEquip\)](https://www.facebook.com/AmericanVanEquip)

[X_\(https://twitter.com/AmericanVan149\)](https://twitter.com/AmericanVan149)

[📷_\(https://instagram.com/americanvan/\)](https://instagram.com/americanvan/)

[📌_\(https://www.pinterest.com/americanvan/\)](https://www.pinterest.com/americanvan/)



[_\(https://www.youtube.com/channel/UCNcZr6yceC5iDcSgX5usJWg\)](https://www.youtube.com/channel/UCNcZr6yceC5iDcSgX5usJWg)

[🌐_\(https://www.americanvan.com/blog/\)](https://www.americanvan.com/blog/)

[in_\(https://www.linkedin.com/company/americanvanequipmentinc\)](https://www.linkedin.com/company/americanvanequipmentinc)

[v_\(https://vimeo.com/user50571179\)](https://vimeo.com/user50571179)

OUR SERVICES

[About Us \(https://www.americanvan.com/about-american-van\)](https://www.americanvan.com/about-american-van)

[Support \(https://www.americanvan.com/contact/\)](https://www.americanvan.com/contact/)

[Catalog Request \(https://www.americanvan.com/catalogorder/index\)](https://www.americanvan.com/catalogorder/index)

[News & Events \(https://www.americanvan.com/news-events\)](https://www.americanvan.com/news-events)

[Subscribe \(https://www.americanvan.com/subscribe-newsletter\)](https://www.americanvan.com/subscribe-newsletter) / [Unsubscribe Newsletter \(https://www.americanvan.com/unsubscribe-newsletter\)](https://www.americanvan.com/unsubscribe-newsletter)

[RSS \(https://www.americanvan.com/rss\)](https://www.americanvan.com/rss)

INFORMATION

[Privacy Policy \(https://www.americanvan.com/privacy-policy\)](https://www.americanvan.com/privacy-policy)

[Return Policy \(https://www.americanvan.com/return-policy\)](https://www.americanvan.com/return-policy)

[Website Terms of Use \(https://www.americanvan.com/website-terms-of-use\)](https://www.americanvan.com/website-terms-of-use)

[Product Sale Terms and Conditions \(https://www.safefleet.net/documents/Ts&Cs-American-Van.pdf\)](https://www.safefleet.net/documents/Ts&Cs-American-Van.pdf)

[Showrooms \(https://www.americanvan.com/showroom\)](https://www.americanvan.com/showroom)

MY ACCOUNT

[Log in \(https://www.americanvan.com/customer/account/login\)](https://www.americanvan.com/customer/account/login)

★ [Wishlist \(https://www.americanvan.com/wishlist\)](https://www.americanvan.com/wishlist)

★ [Checkout \(https://www.americanvan.com/checkout\)](https://www.americanvan.com/checkout)

★ [Order Status \(https://www.americanvan.com/sales/guest/form/\)](https://www.americanvan.com/sales/guest/form/)

[Blog \(https://www.americanvan.com/blog\)](https://www.americanvan.com/blog)

[Sitemap \(https://www.americanvan.com/htmlsitemap\)](https://www.americanvan.com/htmlsitemap)

PAYMENT METHOD, SECURITY & AFFILIATIONS



<https://www.americanvan.com/about>

<https://www.americanvan.com/about>

[american-van\).](https://www.americanvan.com/about)

[american-van\).](https://www.americanvan.com/about)



<https://verify.authorize.net/anelseal/?pid=e0cf9dfe-f34c-4206-be23-d7af17c7ca97&rurl=https://www.americanvan.com>
Accept Credit Cards Online
<http://www.authorize.net/>

Powered by

<https://www.americanvan.com/reviews>



<https://clariencetechnologies.com/>

© 2026 American Van is a subsidiary of Clarience Technologies. All rights reserved. 149 Lehigh Avenue, Lakewood, NJ, 08701

Phone: [\(800\)-526-4743](tel:800-526-4743) (tel:800-526-4743), Fax: (800) 833-8266 Email: ave.salestservice@safefleet.net

[\(mailto:ave.salestservice@safefleet.net\)](mailto:ave.salestservice@safefleet.net)

Quote

Quote expires
May 15, 2026



Leonard Aluminum Utility Buildings, LLC
T/A Leonard Buildings & Truck Accessories
3925 BRISTOL HWY
Johnson City, TN 37601
Phone: 423.282.8617
<http://www.leonardusa.com>
pos544@leonardusa.com

Eric VAN

Ticket #: 544-QUO-106837
Ticket Date: 3/16/26
Station: ECOM

Sold to: WASHINGTON COUNTY DEPT EDUCATION
405 W COLLEGE ST
JONESBOROUGH, TN 37659
none@none.com

Ship to:

Customer #: 544-106607
Sales Rep: OWE005

Ship date:
Location: 544

Ship-via code:
Terms: Net 30 days

Quantity	Item #	Description	List price	Discount	Savings	Price	Ext Price
1	SER-STEP-2	STEP INSTALL FEE				\$150.00	150.00
1	PIMSITEM	N-FAB - NFBGFF19VR-TX				\$389.00	389.00
2	SER-LABOR	Installation Fee				\$75.00	150.00
2	ACC-SHOPSUPPLIES	Installation Supplies				\$12.50	25.00

User: OWE005

Total line items: 16

Sale subtotal: 11,373.00

Sales Tax: 0.00

Thank You For Your Business!
You Saved \$629.91

Total: 11,373.00

Terms & Conditions:

Trailers are not returnable at any time. Items not in new or resalable condition are not returnable at any time.
Special order items, custom painted items, installed items, items sold as is, discontinued or clearance items are not returnable at any time.
Merchandise will not be accepted for return after 30 days of our invoice date. All returned items must be in original condition and packaging.
You will be charged \$20 or 20% restocking fee, whichever is greater on return of non-defective items.
Special Orders cancelled while in progress shall incur a charge for the pro-rated portion of the cost of the item in production -not less than 25% of the quoted price.
If you paid by cash or check - your refund, less fee charges, will be mailed from the corporate office within 7 days of refund request approval.
If you paid by credit card - the credit card used for your payment will be credited, less fee charges, within 7 days of refund request approval.

Prices include Install

Customer signature accepts the above terms and conditions.



Elect.

Quote

Quote expires
May 15, 2026



Leonard Aluminum Utility Buildings, LLC
T/A Leonard Buildings & Truck Accessories
3925 BRISTOL HWY
Johnson City, TN 37601
Phone: 423.282.8617
http://www.leonardusa.com
pos544@leonardusa.com

Ticket #: 544-QUO-106837
Ticket Date: 3/16/26
Station: ECOM

Sold to: WASHINGTON COUNTY DEPT EDUCATION
405 W COLLEGE ST
JONESBOROUGH, TN 37659
none@none.com

Ship to:

Customer #: 544-106607
Sales Rep: OWVE005

Ship date:
Location: 544

Ship-via code:
Terms: Net 30 days

Quantity	Item #	Description	List price	Discount	Savings	Price	Ext Price
1	RAK-48523	52" W X 36" H X 14" D	\$625.99	-\$60.99	-\$60.99	\$565.00	565.00
1	RAK-40090	DRAWER CABINET- 4 DRAWERS	\$429.99	-\$41.99	-\$41.99	\$388.00	388.00
1	RAK-40552	WORKBENCH TOP W/ BACKSPLASH	\$473.99	-\$45.99	-\$45.99	\$428.00	428.00
1	RAK-40070	STEEL 2 DRAWER CABINET UNIT	\$302.99	-\$28.99	-\$28.99	\$274.00	274.00
2	RAK-48524	60"H X 52"W X 14" VAN SHELF	\$1,132.99	-\$109.99	-\$219.98	\$1,023.00	2,046.00
1	PIMSITEM	HOLMAN - 40250				\$2,798.00	2,798.00
1	HOL-40251	LONG HEAVY DUTY DRAWER UNIT SINGLE	\$1,302.99	-\$125.99	-\$125.99	\$1,177.00	1,177.00
16	SER-LABOR	Installation Fee				\$75.00	1,200.00
16	ACC-SHOPSUPPLIES	Installation Supplies				\$12.50	200.00
1	RAK-40660	ROOF PERFORATED PARTITION KIT	\$584.99	-\$56.99	-\$56.99	\$528.00	528.00
1	RAK-40669TH	15-22 FordTransit Divider Wing	\$483.99	-\$48.99	-\$48.99	\$435.00	435.00
1	RBD-RBV09B	15-CU FORD TRANSIT TFX BLK				\$620.00	620.00

Terms & Conditions:

Trailers are not returnable at any time. Items not in new or resalable condition are not returnable at any time.
Special order items, custom painted items, installed items, items sold as is, discontinued or clearance items are not returnable at any time.
Merchandise will not be accepted for return after 30 days of our invoice date. All returned items must be in original condition and packaging.
You will be charged \$20 or 20% restocking fee, whichever is greater on return of non-defective items.
Special Orders cancelled while in progress shall incur a charge for the pro-rated portion of the cost of the item in production -not less than 25% of the quoted price.
If you paid by cash or check - your refund, less fee charges, will be mailed from the corporate office within 7 days of refund request approval.
If you paid by credit card - the credit card used for your payment will be credited, less fee charges, within 7 days of refund request approval.

Customer signature accepts the above terms and conditions.





Electrical
van

Order Toll Free
(800)-526-4743 (tel:(800)-526-4743)
(8:00am - 6:00pm EST Mon. to Fri.)

A Clarifence Technologies Company

[\(https://www.americanvan.com/\)](https://www.americanvan.com/)

CHECKOUT

Please enter your details below to complete your purchase.

Already have an account? [Click here to login](#)

SHIPPING ADDRESS

Email Address *

bella@wcde.org

First Name *

andy

Last Name *

bell

Company

Street Address *

West College Street

City *

Jonesborough

State/Province *

Tennessee

Zip/Postal Code *

37659

Country *

United States

Phone Number *

Extension

Create account

My billing and shipping address are the same

Estimated Total

\$13,670.43

PLACE ORDER



SHIPPING METHODS

\$597.57 LTL Freight AmVan Shipping 

PAYMENT METHODS

Credit Card

 PayPal Express Checkout
 What is PayPal? (<https://www.paypal.com/us/cgi-bin/webscr?cmd=xpt/Marketing/popup/OLCWhatIsPayPal-outsi>)

ORDER SUMMARY

PRODUCT NAME	QUANTITY	SUBTOTAL	ACTION
Composite Partition w/ Window, Transit Mid Roof	1	\$1,087.20	✕
Ford Transit UpStep Mounting Kit (Requires LF-U3RS-18 Step)	2	\$336.00	✕
Transit 130"WB Mid Roof General Service Van Package, Steel Shelving - SAVE \$250!	1	\$6,119.74	✕
Duratherm Wall Liner, Gray - Transit 130"WB, Low Roof	1	\$1,275.00	✕
Wire Reel Rack	1	\$128.80	✕
Pipe & Conduit Holders	1	\$124.50	✕
Aluminum 2-Drawer Unit - 12"W x 40"D x 15"H	1	\$807.20	✕
MSVU-30: Modular Storage Systems For Step Or Cube Van	1	\$802.00	✕
60" Wide Shelving Unit w/ Back and 2 Doors for High Roof Vans	1	\$1,269.40	✕
Cart Subtotal		\$11,949.84	
<input type="radio"/> Shipping or Pickup		\$597.57	
Estimated Total LTL Freight		\$13,670.43	
Tax		\$1,123.02	
ORDER TOTAL		\$13,670.43 	

APPLY DISCOUNT CODE



Estimated Total

\$13,670.43





Electrical van



What are you looking for?



Sign In

Your cart

Subtotal

~~Subtotal~~

Check out

Total is \$12,882.14 Pg 3



Weather Guard Van Wheel Well Storage Cabinet 15"x42"x14" Model 9444-3-01

Price \$477.60-\$398.00

Estimated Delivery : Mar 18 - Mar 23

Quantity

-	1	+
---	---	---

\$398.00

x



Weather Guard Pack Rat Drawer Unit 48X30X9.5 Model 307-3

Price \$2,011.20-\$1,676.00

Estimated Delivery : Mar 18 - Mar 23

Quantity

-	1	+
---	---	---

\$1,676.00

x



Ranger Design Wire Reel Holder for Work Vans Model 7124

Price \$365.00-\$328.50

Estimated Delivery : Mar 24 - Mar 31

Quantity

-	1	+
---	---	---

\$328.50

×



Luverne O-Mega II 6" x 98" Black Aluminum Step Nerf Bars Model 584098-571725

Price ~~\$1,001.94~~ \$834.95

Estimated Delivery : Mar 20 - Mar 24

Quantity

-	1	+
---	---	---

\$834.95

×



Weather Guard Electrical Contractor Van Package High-Roof Ford Transit 148" WB Model 600-8414L

Price ~~\$6,409.30~~ \$5,341.09

Estimated Delivery : Mar 18 - Mar 23

Quantity

-	1	+
---	---	---

\$5,341.09

×



Ranger Design Aluminum Contoured Partition for Ford Transit Low Roof 130" & 148" Wheelbase - Polycarbonate Window Model 3020-FTL

Price ~~\$1,576.00~~ \$1,418.40

Estimated Delivery : Mar 24 - Mar 31

Quantity

-	1	+
---	---	---

~~Elite~~ (optional)



Order summary ▾

This Includes Shipping →

\$12,882.14



Express checkout



Show more options ▾

OR

Contact

[Log in](#)

bella@wcde.org

Email me with news and offers

Delivery

Country/Region
United States ▾

First name

Last name

3

WCDE maintence

307 1/2 forest dr



Apartment, suite, etc. (optional)

jonesborough

State
Tennessee



37659

Phone



Shipping method

Discounted Shipping -

\$346.62

Payment

All transactions are secure and encrypted.

Credit card

VISA



AMEX

+5

Card number



Expiration date (MM / YY)

Security code



Name on card

PURCHASING DEPARTMENT
WASHINGTON COUNTY BOARD OF EDUCATION

FEDERAL PROJECTS FUND
 PURCHASE ORDER

Purchase Order **35917**

Date Issued **3-24-2026**

Appropriation No. **142 E 72210 524 100**
 Dept. **Professional Development**
 School **Jonesborough Elementary**
Title I

TO **Solution Tree**
555 North Morton St
Bloomington, IN 47404

Deliver to **Jonesborough Elementary**
 Address **720 N Cherokee St**
Jonesborough, TN 37659
 Via **Robin Street**

NOTICE TO VENDOR
 1. Purchase order number **MUST** appear on all invoices submitted for payment.
 2. Mail **TWO** copies of your invoice promptly to:
 Washington County Board of Education
 405 West College Street
 Jonesborough, Tennessee 37659
 Telephone (423) 753-1105

on or before

Articles on this order must be charged to account of

ITEM NO.	ARTICLES OR SERVICES	CODE	QUANTITY & UNIT	UNIT PRICE	TOTAL
	(Unless otherwise stated all prices F.O.B. Destination)				
	Time for Change: Leadership Training May 4, 2026		1	\$7,100.00	\$7,100.00
	Yes We Can: Collaborative Opportunities May 5 and 6, 2026		2	\$7,100.00	\$14,200.00
	GRAND TOTAL - INCLUDING ALL ATTACHED PAGES				\$21,300.00

SUBJECT TO THE FOLLOWING CONDITIONS

1. All packages, cartons or other containers must be plainly marked with the purchase order number.
2. The right is reserved to purchase in the open market and to charge the difference to the Vendor in the event that deliveries are not made at the time specified in the bid and on this order.
3. Whenever a delivery is rejected, the Vendor shall be notified and be given the reason for the rejection. All rejected deliveries shall be held at the Vendor's risk and he shall bear the expense of removal.
4. No changes in or cancellations of this purchase order shall be recognized by the Vendor unless authorized by special form issued by the Purchasing Agent.
5. Acceptance of this order includes acceptance of all terms, prices, delivery, instructions, specifications and conditions stated.
6. The county is not liable for Federal excise tax or state sales tax.
7. Each shipment and/or each purchase order should be covered by separate invoice.

IMPORTANT: INVOICES AND PACKAGES MUST BEAR PURCHASE ORDER NUMBER

VENDOR'S COPY	There is an otherwise unincumbered balance to the credit of the proper appropriation, allotment or fund to meet the expenditure covered by this purchase.	APPROVED:
	Authorized Signature	Purchasing Agent



Solution Tree

555 North Morton Street
Bloomington IN 47404
United States

Phone: 800-733-6786
Fax: 812-336-7790

www.SolutionTree.com

Quote

#QS138100

3/24/2026

Bill To

Washington Co. BOE
405 W College St
Jonesborough TN 37659
United States

Ship To

Jonesborough Elementary
720 N Cherokee St
Jonesborough TN 37659
United States

TOTAL

\$21,300.00

Prices subject to change without notice.

PO #**Terms**

Net 30

Customer ID

130235

Shipping Method

Not Applicable

Item**Rate****Quantity****Extension**

SPD508 Professional Development

\$7,100.00

3

\$21,300.00

3 days of Onsite Professional Development

Subtotal

\$21,300.00

Sales Tax Total

\$0.00

Shipping Cost

\$0.00

Total

\$21,300.00

**Federal Programs
Professional
Development
Request Form**



RECEIVED
3-3-2026

APPROVED: JLW
DENIED: _____
DATE RECEIVED: _____
ORDERED: _____
P.O. NUMBER: _____
DATE COMPLETED: _____

SCHOOL: JES
PRINCIPAL'S SIGNATURE: [Signature]
DATE: 3-2-26
Committee approved Y N (noted in meeting minutes)

The Title I School Improvement Council requests that the following personnel attend the PD below:

Title of Professional Development: Yes We Can: Collaborative Opportunities to Improve

Location of Professional Development: General Education and Special Education - JES

Date of Professional Development: May 5, 2026 through May 6, 2026 Presenter's Name: SO

Description of Professional Development: This full-faculty training focuses on building

culture centered on the belief that all students can succeed. The session will emphasize

structures that support high levels of learning and clarify the connections between RTI,

Which curriculum area will be targeted and how will the effectiveness of this PD be measured? col

The focus will be on collaboration of RTI, PLCs and SPED in all academic areas

be discussed at weekly PLCs by presenting student work samples and data.

* Attendees are responsible for redelivering the information received during the PD session to faculty

To be completed by person requesting PD:

To be completed if ordering supplies for PD: (attach

- ___ To be completed if traveling to PD:
- ___ Number of people attending
- ___ Registration cost per person
- ___ Number of miles to and from PD
- ___ Number of people driving
- ___ Number of rooms
- ___ Number of nights

Attach: Conf. info. & list of participants

To be completed for on campus PD:

Rev
11/26

PD Resource: Solution Tree
Number of participants: entire faculty
Total cost of PD: \$7,100 x 2 = \$14,200

Vendor: (name, address, phone #, website)
Name: <u>Solution Tree</u>
Address: <u>555 North Morton St.</u> <u>Bloomington, IN 47404</u>
Phone #: <u>800-733-6786</u>
Website: <u>www.solutiontree.com</u>
Total cost of supplies: <u>\$14,200</u>

Federal Programs
Professional
Development
Request Form



RECEIVED
3-3-2026

APPROVED: JK
DENIED: _____
DATE RECEIVED: _____
ORDERED: _____
P.O. NUMBER: _____
DATE COMPLETED: _____

SCHOOL: JES
PRINCIPAL'S SIGNATURE: Robin Street
DATE: 3-2-26

Committee approved Y N (noted in meeting minutes)

The Title I School Improvement Council requests that the following personnel attend the PD below:

Title of Professional Development: Time for Change: Leadership Team Training

Location of Professional Development: JES

Date of Professional Development: May 4, 2026 through N/A Presenter's Name: _____

Description of Professional Development: The session focuses on strengthening rebuilding trust, overcoming resistance to change, and developing systems both accountability and professional growth.

Which curriculum area will be targeted and how will the effectiveness of this PD be measured? Equip the school's leadership team to effectively guide improvement in a culture of high expectations.

* Attendees are responsible for redelivering the information received during the PD session to faculty.

To be completed by person requesting PD:

To be completed if ordering supplies for PD: (attach

- ____ To be completed if traveling to PD:
- ____ Number of people attending
- ____ Registration cost per person
- ____ Number of miles to and from PD
- ____ Number of people driving
- ____ Number of rooms
- ____ Number of nights

Attach: Conf. info. & list of participants

To be completed for on campus PD:

Rev
1/26

PD Resource: Solution Tree
Number of participants: entire faculty
Total cost of PD: \$7,100

Vendor: (name, address, phone #, website)

Name: Solution Tree

Address: 555 North Morton St.
Bloomington, IN 47404

Phone #: 800-733-6786

Website: www.solutiontree.com

Total cost of supplies: \$7,100

Specifications for Replacement of Intercom System

**David Crockett High School
684 Old State Route 34, Jonesborough, TN 37659**

Article I - Qualifications

1. Successful Bidder shall possess no less than 10 years of experience in the installation and service of Intercommunication systems.

Article II - Requirements

1. Bidder shall replace the existing intercom system in accordance with the product manufacturer's Specifications and Requirements.
2. Bidder shall have no less than \$1,000,000 liability insurance coverage.
3. Bidder shall be available to provide service within 24 hours of notification that there is a failure or other problem with the operation of the system.

Article III - Scope of Work

1. Bidder shall replace the Master Intercom and Classroom Telephone Systems including all speakers inside and outside, all classroom speakers and telephones and any associated devices. The existing wiring and raceways, etc., may be used if it is determined said wiring is compatible with the system that is being installed. See Appendix A.
2. Bidder shall install a minimum of two (2) 15-watt paging horns with protective cages in the gymnasium for proper intercom operation. See Appendix A.
3. Bidder shall provide any and all wiring, raceways cross connects, conduits, boxes, and any other hardware as needed to provide a complete and functional system.
4. Bidder shall be allowed to work during normal school hours so long as the scope of work does not cause disruptions to class time learning. Any work causing a disruption will be performed outside of normal school hours.
5. Bidder shall connect system via Network for remote access to make appropriate adjustments. Washington County will provide a network drop and Network parameters.

Article IV - Completion and Training

1. Bidder shall provide a complete one (1) year warranty on all new equipment that is installed beginning on the day of System completion.
2. Bidder will provide training for any designated staff member or employee of the Washington County School System, so that said staff or employee can operate/use the System as specified by the System manufacturer.
3. Bidder shall provide one (1) employee of the Washington County System with factory training to the extent that said employee shall possess the knowledge, skill, manuals, software, etc., to properly edit, change, modify, or add to the system as needed for expansion and/or maintenance of the system.
4. Bidder shall provide a Certificate of Completion and Test to the Washington County School System Central Office.
5. All installation and training must be completed by Friday, June 19, 2026.

Article V - Other Notes

The existing intercom is a Dukane Modular Administrative Communications System (MACS) with digital clocks. If the new system being bid is not compatible to operate these clocks, then the existing main unit with the Administrative Telephone shall remain in service to drive the school clocks.

Appendix A - Materials list

Quantity	Model	Description
60	BO-CSD2X2VRU	BOGEN CEILING DROP SPKRS 2 PACK
1	6V-VACS25	VALCOM 24 ZONE INTERCOM
1	6V-VACSX7225	VALCOM EXPANSION CARD FOR ACS25
1	6V-VEADP4	VALCOM ADMIN STATION
2	6V-V9939C	VALCOM PAGE ADAPTOR
2	BO-PS240G2	BOGEN 250W AMPLIFIER
2	BO-RPK44	BOGEN RACK KIT
24	312/25T	FOURJAY PAGING HORNS
1	VS-5591-DTIB	VERTICAL TELEPHONE KIT
3	VS-5532-24	24 DKT INTERFACE BOARD
4	VU-9224-00	VERTICAL 24 BUTTON TELEPHONE OFFICE
10	VU-9208-00-8P	8 PACK 8 BUTTON TELEPHONE
75	VIP-9002-WM	VERTICAL EDGE VIP-9002 AND VU-9208 W.M.
4	WG-21211101	HONEYWELL 16/2 WHITE STRANDED
2	CROSSCONNECT	CROSSCONNECT CABLE
12	66M150	BLOCKS
12	S89	BRACKETS
4	M2-5WM	CONNECTOR BLOCKS
4	25-3-CC-15GY	25 PAIR CABLE WITH FEMALE CONNECTOR
	LABOR	LABOR TO INSTALL & PROGRAM

Specifications for Replacement of Intercom System

**West View Elementary School
2847 Old State Rt 34, Limestone, TN 37681**

Article I - Qualifications

1. Successful Bidder shall possess no less than 10 years of experience in the installation and service of Intercommunication systems.

Article II - Requirements

1. Bidder shall replace the existing intercom system in accordance with the product manufacturer's Specifications and Requirements.
2. Bidder shall have no less than \$1,000,000 liability insurance coverage.
3. Bidder shall be available to provide service within 24 hours of notification that there is a failure or other problem with the operation of the system.

Article III - Scope of Work

1. Bidder shall replace the Master Intercom and Classroom Telephone Systems including all speakers inside and outside, all classroom speakers and telephones and any associated devices. The existing wiring and raceways, etc., may be used if it is determined said wiring is compatible with the system that is being installed. See Appendix A.
2. Bidder shall install a minimum of two (2) 15-watt paging horns with protective cages in the gymnasium for proper intercom operation. See Appendix A.
3. Bidder shall provide any and all wiring, raceways cross connects, conduits, boxes, and any other hardware as needed to provide a complete and functional system.
4. Bidder shall be allowed to work during normal school hours so long as the scope of work does not cause disruptions to class time learning. Any work causing a disruption will be performed outside of normal school hours.
5. Bidder shall connect system via Network for remote access to make appropriate adjustments. Washington County will provide a network drop and Network parameters.

Article IV - Completion and Training

1. Bidder shall provide a complete one (1) year warranty on all new equipment that is installed beginning on the day of System completion.
2. Bidder will provide training for any designated staff member or employee of the Washington County School System, so that said staff or employee can operate/use the System as specified by the System manufacturer.
3. Bidder shall provide one (1) employee of the Washington County System with factory training to the extent that said employee shall possess the knowledge, skill, manuals, software, etc., to properly edit, change, modify, or add to the system as needed for expansion and/or maintenance of the system.
4. Bidder shall provide a Certificate of Completion and Test to the Washington County School System Central Office.
5. All installation and training must be completed by Friday, May 29, 2026.

Article V - Other Notes

The existing intercom is a Dukane Modular Administrative Communications System (MACS) with digital clocks. If the new system being bid is not compatible with the operation these clocks, then the existing main unit with the Administrative Telephone shall remain in service to drive the school clocks.

Appendix A - Materials list

Quantity	Model	Description
38	BO-CSD2X2VRU	BOGEN CEILING DROP SPKRS 2 PACK
1	BO-WBS8WT725	BOGEN WAL BAFFLE KITCHEN
1	6V-VACS25	VALCOM 24 ZONE INTERCOM
1	6V-VACSX7225	VALCOM EXPANSION CARD FOR ACS25
1	6V-VEADP4	VALCOM ADMIN STATION
2	6V-V9939C	VALCOM PAGE ADAPTOR
2	BO-PS120G2	BOGEN 120 WATT AMPLIFIER
2	BO-RPK2	BOGEN RACK KIT
10	312/25T	FOURJAY PAGING HORNS
1	VS-5591-DTIB	VERTICAL TELEPHONE KIT
1	VS-5532-24	24 DKT INTERFACE BOARD
2	VU-9224-00	VERTICAL 24 BUTTON TELEPHONE OFFICE
6	VU-9208-00-8P	8 PACK 8 BUTTON TELEPHONE
43	VIP-9002-WM	VERTICAL EDGE VIP-9002 AND VU-9208 W.M.
1	CROSSCONNECT	CROSSCONNECT CABLE
2	M2-5WM	CONNECTOR BLOCKS
4	25-3-CC-15GY	25 PAIR CABLE WITH FEMALE CONNECTOR
	LABOR	LABOR TO INSTALL & PROGRAM



Mr. Jerry S. Boyd
Superintendent

405 W. College St.
Jonesborough, TN 37659
Phone (423) 753-1100

REQUEST FOR PROPOSALS

Beverage Vendor proposal for Washington County, TN Schools

The following items are requested needs for the proposal:

1. Provide detailed schedule for updating and maintaining product logos for all scoreboards;
2. Provide \$ _____ sponsorship per year;
3. Provide \$ _____ for scholarships per year;
4. Provide \$ _____ for scoreboard purchases per year;
5. Pay rebate of \$ _____ per case on purchases through concessions;
6. Provide the commission rates for sold items;
7. Provide a minimum number of drink machines in each school, based on student enrollment, with at least one machine per 200 students;
8. Provide detailed schedule for servicing drink/vending machines at all WCS buildings;
9. Provide _____ complimentary cases of products per year for Central Office Board Meetings;
10. Any other services vendor may opt to provide.

We appreciate the opportunity to receive your proposal to serve our community through being a partner with your organization.

Send a completed RFP and any pertinent items in a SEALED envelope by mail or bring to Dr. Jarrod Adams, Washington County Schools, 405 West College Street, Jonesborough, Tennessee, 37659, so to arrive no later than the date and time given of the scheduled public opening.

For RFP Identity, clearly mark "Beverage Vendor RFP" on the outside of the envelope.

Beverage Vendor

RFP to be opened Thursday April 23, 2026, 2:00 PM EST

Business has read RFP with specifications, understands, and by submitting this proposal hereby agrees, upon receiving a Washington County Board of Education purchase order as notification of award, to furnish all products and services as specified, described or reasonably implied including pre-disposal fee, shipping and delivery "AS NEEDED" to

Washington County Schools
405 W. College St.
Jonesborough, Tennessee 37659

per following detail of RFP with any EXCEPTIONS to specifications listed below, if necessary. If none, state 'no conditions and/or exceptions'.

EXCEPTIONS:

Board of Directors

Eric Barnes
Annette Buchanan
Keith Ervin

Chad Fleenor
David Hammond
Gregg Huddlestone

Mike Masters
Whitney Riddle
Vince Walters



WASHINGTON
COUNTY SCHOOLS

INSPIRE ★ STRIVE ★ THRIVE

Mr. Jerry S. Boyd
Superintendent

405 W. College St.
Jonesborough, TN 37659
Phone (423) 753-1100

April 3, 2026

INVITATION TO BID

Kitchen Flooring-West View and Sulphur Springs Schools

Washington County Schools is seeking sealed bids from qualified, licensed, and insured flooring contractors for the application of industrial kitchen tiles for the kitchens at West View Elementary School and Sulphur Spring Elementary School. Bids will be accepted until **2:00 PM EST on Tuesday, April 21, 2026**, at which time bids will be publicly opened and read aloud at the Central Office address listed below. Bidders and their representatives are welcome to attend the bid opening. Any bid received after the deadline will be returned to the sender unopened.

The successful bidder must provide proof of insurance and any required licensing for the state of Tennessee. Additionally, they must maintain documentation of clear background checks for all employees who will be present on school premises.

The Washington County Board of Education reserves the right to reject any or all bids, accept parts of bids, and award contracts based on the best value for educational use, which may not necessarily be the lowest bid. Awards may also be made by individual groupings as identified by item number. WCS reserves the right to terminate the contract with 30 days' written notice in the event of a breach of contract or unsatisfactory service. The Board's decision will be final.

Bid Pricing Requirements:

The price quoted must be comprehensive and include all items of the bid, disposal fees, shipping, handling, and delivery to:

**Sulphur Springs Elementary School, 1518 Gray Station/Sulphur Springs Rd.
Jonesborough, TN 37659.**

West View Elementary School, 2847 Old State Rte 34, Limestone, TN 37681

Complete bids for any item will receive full consideration. Any exceptions to specifications must be detailed on the attached sheet.

Successful bidding firms, if any, will be notified through a Washington County Board of Education purchase order following Board approval. Payment will be made in full within **15 days** of delivery, receipt of invoice, and acceptance of completed work. The Board of Education is tax-exempt, and a tax exemption form can be provided upon request.

Board of Directors

Eric Barnes
Annette Buchanan
Keith Ervin

Chad Fleenor
David Hammond
Gregg Huddleston

Mike Masters
Whitney Riddle
Vince Walters



WASHINGTON COUNTY SCHOOLS

INSPIRE ★ STRIVE ★ THRIVE

Mr. Jerry S. Boyd
Superintendent

405 W. College St.
Jonesborough, TN 37659
Phone (423) 753-1100

For any questions regarding these specifications, please contact Jeremy Moore at **(423) 753-1129**. Any changes to specifications will be issued via addendum and made available to all prospective bidders on our website at www.wcde.org/bids.

SCOPE OF WORK

The selected contractor will furnish all labor, materials, tools, equipment (including lifts and safety gear), supervision, and services necessary to complete the job as specified. The work must adhere to all local, state, and federal regulations. **Estimated start date no earlier than June 8, 2026 with an expected completion date no later than July 24, 2026, including contingencies for any delays.**

Key tasks must include:

- **Inspection and Preparation:** Conduct a thorough assessment of the existing kitchens to identify all areas requiring new flooring;
- **Cleaning:** Clean the entire floor surface with appropriate cleaning agents to remove all dirt, dust, chalking, oils, and loose materials. Allow adequate drying time;
- **Flooring Application:** Apply kitchen tile in strict accordance with the manufacturer's published installation manuals;
- **Quality Control:** Ensure proper adhesion and seamless coverage across the entire surface, protecting adjacent property during the process;
- **Cleanup and Disposal:** Include all costs for debris disposal and final site cleanup in the bid;
- **Warranty:** Provide both a manufacturer's material warranty and a contractor's workmanship warranty.

Submittal Requirements

Bidders must provide a comprehensive proposal including the following:

- **Company Information:** Full business name, address, contact information, email, license number, and the name and signature of an authorized representative;
- **Proof of Insurance:** Current certificates of General Liability Insurance and Workers' Compensation Insurance;
- **Material Specifications:** Specific product data sheets for the proposed kitchen tiles;
- **Warranty Information:** Explicit terms and duration of both the material and workmanship warranties.

Board of Directors

Eric Barnes
Annette Buchanan
Keith Ervin

Chad Fleenor
David Hammond
Gregg Huddleston

Mike Masters
Whitney Riddle
Vince Walters



Mr. Jerry S. Boyd
Superintendent

405 W. College St.
Jonesborough, TN 37659
Phone (423) 753-1100

Terms and Conditions

- **Bid Validity:** All bids must be valid for a minimum of 60 days from the submission deadline.
- **Selection Criteria:** Bids will be evaluated based on price, material quality, contractor experience and reputation, warranty terms, and the completeness of the proposal.
- **Site Visit:** All bidders are encouraged to visit each site location. A time may be scheduled with WCS Maintenance Director Jeremy Moore who can be reached at 423-753-1129 or moorej4@wcde.org

Submission Instructions

Bids must be received no later than the deadline specified above. Submissions should be delivered to Dr. Jarrod Adams 405 W. College St. Jonesborough, TN 37659 in a **sealed envelope** with the subject line “Bid for Kitchen Flooring”.

TOTAL BID AMOUNT: \$ _____

Board of Directors

Eric Barnes
Annette Buchanan
Keith Ervin

Chad Fleenor
David Hammond
Gregg Huddlestone

Mike Masters
Whitney Riddle
Vince Walters



WASHINGTON COUNTY SCHOOLS

INSPIRE ★ STRIVE ★ THRIVE

Mr. Jerry S. Boyd
Superintendent

405 W. College St.
Jonesborough, TN 37659
Phone (423) 753-1100

By submitting this bid, the bidder agrees that the quoted products and services meet the stated specifications and will remain in compliance with Washington County Board of Education standards throughout the contract period.

Bidder Information:

Printed Name: _____

Signature: _____

Telephone #: _____

Cell #: _____

Fax #: _____

Company Name: _____

Mailing Address: _____

City/State/ZIP: _____

Date: _____

Email Address: _____

Exceptions (If none, state “No conditions and/or exceptions.”)

Board of Directors

Eric Barnes
Annette Buchanan
Keith Ervin

Chad Fleenor
David Hammond
Gregg Huddlestone

Mike Masters
Whitney Riddle
Vince Walters

Capital Funds for Technology (\$500,000.00)
Purchase requests

Item	Unit Cost	Units	Item Subtotal
Chromebooks	461.67	625	\$288,543.75
Aruba 635 APs	627.75	330	\$207,157.50
Mounts for APs (10 pack)	119.25	33	\$3,935.25
			<hr/>
			\$499,636.50

DIGITAL MULTI-MEDIA PRESS

XANTÉ

EN/PRESS®



■ PlateMaker **8**
INSIDE

■ Includes
iQueue 14

*Simply Brilliant Workflow
with iQueue Mail - USPS® certified
address verification, correction,
sorting, and barcoding!*



■ **ENTERPRISE-SP**
COMPACT HIGH SPEED SYSTEM



Reliable. Profitable. Production.

The En/Press Digital Multi-Media Press with the patented Enterprise High Speed Feed System offers users an affordable way to go digital and meet the demand for fast, full-color printing. Enterprise's groundbreaking design features a straight feed path for a faster and smoother delivery. The complete digital solution is powered by iQueue Simply Brilliant Adobe Postscript PDF® Workflow that offers Dead-On Spot Color Matching, advanced variable data capabilities, full imposition, intelligent sequential numbering, over a thousand royalty free customer-ready templates and so much more.

Improve In-House Productivity

En/Press Digital Multi-Media Print Systems allow you to do more for your customers, in-house

- Print on a wider variety of media and in a wider range of sheet sizes.
- Up to 4,000 full color envelopes per hour
- Features a lower cost per sheet
- Run full color jobs including variable data in one pass.
- iQueue Simply Brilliant Workflow automates prepress production and provides critical color adjustments.



Booklets



NCR Forms

Astonishing Full-Color Results

The En/Press Digital Series features a multi-bit print engine that delivers production color and print quality your customers demand

- Resolutions up to 4800 for exceptional sharpness, clarity and color quality.
- iQueue can match any spot color that can be created with CMYK **dead-on every time**. Xanté's patented RightON® color matching technology makes spot color matching simpler than ever.
- New HD toner offers a wider color gamut. The smaller particles enable the En/Press Digital Color Series to capture subtle changes in color and tone.
- Output is waterproof and laser safe.

More Media / Feed Choices

Outstanding media flexibility allows you to offer your customers more and helps eliminate costly outsourcing

- Prints on a variety of stocks including: Uncoated, coated, NCR, card stocks, textured stocks, label stocks and envelopes (from 3.5" x 3.5" up to 13" x 49").
- Prints on 18pt cover (400gsm).
- Print oversized sheets / banners up to 13" (330 mm) x 49.6" (1260 mm).

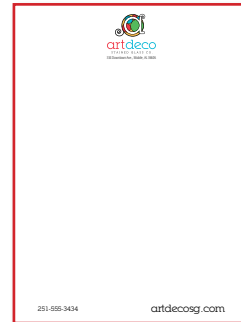
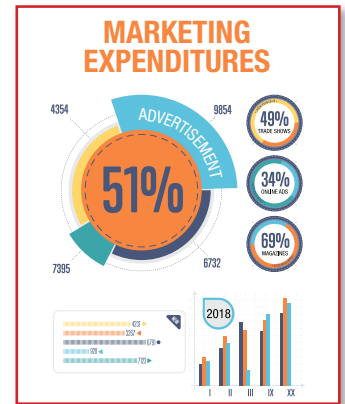
Full color sheets, envelopes and cards



Label stocks

Computer-to-Plate

PlateMaker 8

INSIDE

Xanté is pleased to announce a revolutionary advancement in Computer-to-plate (CTP) printing technology. The En/Press Revolutionary Digital Multi-Media Press with PlateMaker 8 inside is a brand new polyester CTP system. Specifically designed for small commercial printers, this solution is low cost, high quality, chemical free, and fast. The best part is that it's all contained WITHIN the En/Press which is already the best way to print your envelopes, NCR forms, stationery, invitations, announcements and more!



PlateMaker 8 Specifications	
Myriad 2 Plates	Available in the following sizes: 10" x 15" - 13" x 19 ⁷ / ₈ "
340mm Option	13 ³ / ₈ " x 19 ⁷ / ₈ " (340mm x 505mm)
Plate Thickness	4 mil plates

Customize with the Feeder System that works for your needs. (Enterprise-SP or the complete Enterprise Feed System)



- **THE BEST envelope feed system IN THE WORLD**
- Load up to 1,000 #10 envelopes and walk away
- Quick adjust guides for faster media changes

Available in five configurations:

1. Standalone
2. Standalone with the Compact Enterprise-SP Feeder (500 #10 envelopes)
3. Digital Production Press with the Enterprise (1,000 #10 envelopes)
4. Additional Trays (2 Extra trays for up to 12.5"x18")
5. High Capacity (Hi-Cap Tray for Letter or A4)



- **NEW COMPACT DESIGN**
33" x 11.5" x 20"
- Load up to 500 #10 Envelopes
- Media from 3.5" x 3.5" up to 13" x 49"
- Load media on-the-go



US Pat. No. 8939274 B1

EN/PRESS



ENGINE SPECIFICATIONS

Configuration	Desktop
Technology	Laser-beam scanning & electrophotographic printing with dual component toner development, 4-drum tandem method, output water proof and laser safe
Printing Speed	Color 60 ppm / Black & White 60 ppm / 75 #10s ppm 60, 26 and 17 ppm for letter/A4 depending on media thickness Envelopes less than 8.5" in width 25 ppm
Warm-Up Time	22 seconds or less
First Print Speed	8 seconds or less
Duplex Print Speed	Near 100% productivity for all paper sizes
Print Resolution	600, 1200, 2400 or 4800
Input Capacity	Standard: 2 x 550 sheets + 100-Sheet Bypass Tray
Output Capacity	Standard: 500 sheets face down
Paper Sizes	
Feed Tray 1:	Letter / A4
Feed Tray 2:	Min: 7.17" W x 5.83" L (182 x 148 mm) Max: SRA3* 12.5" W x 18" L (320 x 457 mm)
Multi-Purpose Tray:	Min: 3.5" W x 3.5" L (89 x 89 mm) Max: 13" W x 49.6" L (330 x 1260 mm)*
High Capacity Tray:	8.5" W x 11" L (216 x 279 mm)
Dual Tray:	Min: 7.17" W x 5.83" L (182 x 148 mm) Max: SRA3* 12.5" W x 18" L (320 x 457 mm)
Paper Weights	
First / Second Tray:	16 - 68 lb. Bond - 14pt Cover (60 - 320 gsm)
Bypass Tray:	16 - 68 lb. Bond - 18pt Cover (60 - 400 gsm) Feed source for Labels, OHP and Envelopes
Duplex Unit:	60 - 256 gsm
Paper Types	Bond, Plain, Recycled, Preprinted, Special, Color, Letterhead, Card Stock, Glossy, Coated, Labels, OHPs and Envelopes (4 Bar, Monarch, #10, window* and larger)
Auto Duplex	Standard
Dimensions (Base Model)	23.2" W x 27" D x 28.6" H (587 x 685 x 725 mm) (Standard Configuration)
Weight (Base Model)	With consumables loaded (except toner) 187 lb. (85 kg)
Power	120-127V / 220-240V (50/60 Hz)
Operating Power	992W Consumption
Maximum Power	1.854 kw or less
Energy Saver	2.2W

PRINTER CONTROLLER (Standard)

CPU	Intel Atom Processor Bay Trail 1.75GHz
Memory	2 GB
Hard Disk Drive	320 GB HDD Standard on all models
Printer Languages	PCL 5c, PCL 6, RPCS, Adobe® PS® 3™, PDF Direct Print
Fonts	Standard: 45 PCL fonts, 13 Intl Fonts, 136 PS 3 fonts Optional: OCR and Barcode fonts available
Standard Interface	Ethernet (1000Base-T/100Base-TX/10Base-T), USB 2.0, SD Slot
Operating Systems	Windows 7 to current / Mac OS 10.7 to current

SYSTEM SPECIFICATIONS

ENTERPRISE HIGH SPEED FEEDER

Capacity	Load up to 1,000 #10 (241 x 105mm) Envelopes
Media Sizes	3.5" x 3.5" (89 x 89 mm) - 13" x 49.6" (330 x 1260 mm)
Paper Weights	16 - 68 lb. Bond - 18pt Cover (60 - 400 gsm)

ENTERPRISE-SP COMPACT HIGH SPEED FEEDER

Dimensions	33" x 11.5" x 20" (84cm x 29cm x 51cm)
Capacity	Load up to 500 #10 (241 x 105mm) Envelopes
Paper Sizes	3.5" x 3.5" (89 x 89 mm) - 13" x 25.5" (330 x 648 mm)
Paper Weights	16 - 68 lb. Bond - 18pt Cover (60 - 400 gsm)

SUPPLIES

Consumables	Yield (ISO 19,798 Yields)	Consumables	Yield
Black Toner	43,000 pages	Yellow Toner	34,000 pages
Mag. Toner	34,000 pages	Cyan Toner	34,000 pages
Fuser	160,000 pages*	Imaging Drums	120,000 pages*
Image Transfer Belt	200,000 pages*		
Part Numbers			
Cyan Toner	200-100373	Cyan Drum	200-100377
Magenta Toner	200-100374	Magenta Drum	200-100378
Yellow Toner	200-100375	Yellow Drum	200-100379
Black Toner	200-100376	Black Drum	200-100380
		CMY Drum Set	200-100381
110V Fusing Unit	200-100383	Transfer Belt	200-100382
220V Fusing Unit	200-100384	Waste Toner Bottle	200-100387

En/Press ships with starter toner cartridges that yield 21,500 pages for Black and 17,000 pages for each color. *based on letter/A4 size pages at 5% coverage. Use only Xanté or Xanté approved consumables.



iQueue Simply Brilliant Workflow (Included)

Digital Color Workflow with Advanced Color Matching and File Management Tools



FULLY VERIFIED, CORRECTED, SORTED, AND BARCODED!

Available Features:

- USPS® certified address verification, correction, sorting, and barcoding
- Over a Thousand Design Templates
- Multi-Part Form Design
- Sequential Numbering
- Booklet Creation
- Universal Print Driver
- Independent CMYK Color Controls
- Patented Spot Color Matching
- Job Cost Estimator
- Full Imposition and Tiling
- Custom Barcode Generator
- Import Variable Data with Intelligent Mail barcodes*
- Automatic Creep Adjustment and more

XANTÉ
xante.com

US: 251.473.6502

EU: +31 (0) 26.319.3210



Adobe® PostScript® 3™

©2020 Xanté Corporation. All rights reserved. Xanté, HWC, iQueue, iQueue Mail and Right-On are trademarks or registered trademarks of Xanté Corporation. Adobe, Adobe PDF, and PostScript 3 are registered trademarks of Adobe Systems, Incorporated. USPS® is a registered trademark of the United States Postal Service. All other trademarks or registered trademarks are the property of their respective owners. The Specifications listed here are subject to change without notice.

*Paper size only. **Laser safe window envelopes only. Patent pending technology. *Call for details.
02.19.2020

XANTÉ EN/PRESS

DIGITAL MULTI-MEDIA PRESS

COST PER PRINT (CPP)

CPP Includes All Consumables

5" x 7" 4-Color Wedding Invitation
\$0.014 each
\$14.07 per 1,000

A7 4-Color Wedding Envelope
\$0.025 each
\$25.12 per 1,000

4-Color Wedding Menu
\$0.008 each
\$7.79 per 1,000

4-Color RSVP Card
\$0.005 each
\$4.86 per 1,000

4-Color RSVP Envelope
\$0.013 each
\$12.52 per 1,000

5" x 7" 4-Color Save the Date
\$0.01 each
\$11.20 per 1,000

4-Color Complete Wedding Set
\$0.08 per set

4-Color Letterhead
\$0.02 each
\$20.20 per 1,000

#10 4-Color Envelope
\$0.012 each
\$12.42 per 1,000

4-Color Stationery Set
\$0.036 per set
\$35.91 per 1,000

4-Color Business Cards
\$0.003 each
\$3.29 per 1,000

4-Color Business Cards
\$0.003 each
\$3.08 per 1,000

Print your own
full color business envelopes
for around 1¢ each!

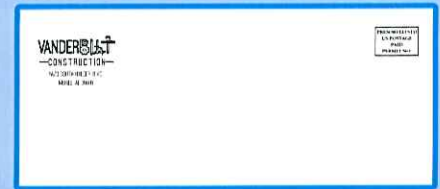

#10 1-Color Envelope \$0.006 each
\$5.48 per 1,000



#10 2-Color Envelope \$0.012 each
\$11.91 per 1,000



#10 4-Color Envelope \$0.012 each
\$11.70 per 1,000



#9 1-Color Return Envelope \$0.006
\$5.68 per 1,000

11" x 25.5" 4-Color Trifold
\$0.35 each
\$350.53 per 1,000

Washington County
Department of
Education

Production Print
Proposal



RJY Young

Technology Solutions That Power Your Business

February 13, 2026

PREPARED BY:

Will White

423-276-0141

will.white@rjyoung.com

Xante En/Press

Pricing Components

- **Xante En/Press**
 - Enterprise Feeder
 - Conveyor Belt
 - Stand
 - iQueue Workflow Software
- **Includes Training and Installation**
- **Includes 1 year of Right Care Service**

Financial Summary

Purchase Price	\$18,615.10
60 Mo 1\$ Buyout Lease	\$ 440.50/mo

Omnia Contract # 2021002788

Supply/ Consumable MSRP Pricing and Estimated Yields:

Black Toner - (43K yield)	\$110.00
Cyan Toner - (34K yield)	\$220.00
Magenta Toner - (34K yield)	\$220.00
Yellow Toner - (34K yield)	\$220.00
CMY Color Drum Kit - (120K yield)	\$897.00
Black Drum - (120K yield)	\$299.00
Fuser Unit - (160K yield)	\$449.00
Transfer Belt - (200K yield)	\$349.00
Waste Toner Bottle	\$55.00

Yields based on 5% area coverage

Average Cost is .01/envelope for 5% Coverage





RJJ Young

Technology Solutions That Power Your Business

Envelopes by School	Boxes			
Asbury	3			
Boones Creek	7			
Daniel Boone	16			
David Crockett	16			
Fall Branch	7			
Grandview	7			
Gray	7			
Jonesborough	7			
Lamar	7			
Ridgeview	7			
South Central	7			
Sulphur Springs	7			
West View	7			
Central Office	3			
	Total	108		
1 Box=500 Envelopes		54,000		
The average to print a box of envelopes (500) is \$115 per box that would come to \$12,420 per year				



7776 S Pointe Parkway Suite 136 Phoenix AZ 85044
Phone: 833-254-6864

BILLING and SITE INFORMATION:

Customer: Grandview Elementary School

Address: 2891 US-11E

City: Telford **State:** TN

Contact Person/Title: Jeremy Moore

Billing Email:

Address:

Zip: 37690

Phone:

Contact Person Email: moorej4@wcde.org

CUSTOMER EQUIPMENT LOCATION (if other than Billing Address):

Name: Same as Above

Address:

City: **State:**

Zip:

Phone:

Contact Person/Title:

Contact Person Email:

COMPACTION EQUIPMENT:

Equipment Type: 34yd Self-Contained Compactor with Left-Side Feed Doghouse

Equipment Type:

Additional Equipment Description: Trade In Offer

Contract Start Date: Upon Singature

PO#:

TRADE-IN EQUIPMENT & CREDIT DETAILS:

Equipment Type: 34yd Self-Contained Compactor with Left-Side Feed Doghouse

Additional Equipment Description:

The agreed fair market value of the Trade-In Equipment is \$ 6,000.00 ("Trade-In Value"). The Trade-In Value has been applied to the Monthly Fee set forth herein this Agreement.

1. **Contract Term.** This Agreement (“Agreement”) is entered into as of the last date set forth below, by and between Compactor Rentals of America, LLC (“Company”), and the Customer set forth above (“Customer”). The initial term of this Agreement is **60-month** (“Initial Term”), commencing on the date of installation of the above Equipment, as more particularly set forth in the Installation Checklist provided by Company to Customer. The Initial Term shall be automatically renewed for successive terms, each in the same duration as the Initial Term (each a “Renewal Term,”) and together with Initial Term, the (“Contract Term”) without further action; *provided, however*, this Agreement may be terminated at the end of any Contract Term by either of the parties by giving notice to terminate by certified mail received by the other not less than sixty (60) days prior to the expiration of the then pending Contract Term, and no more than one hundred twenty (120) days prior to the expiration of then pending Contract Term.
2. **Payments.** Customer agrees to pay a monthly equipment rental and service fee of \$ \$600.00 plus any applicable sales or other taxes, per month (“Monthly Fee”), directly to Company. Customer shall then make payments to Company based on net 30 day terms established with the Company (“Payment Due Date”). Company may impose, and Customer agrees to pay, a late fee in the amount of five percent (5%) of the Monthly Fee for delinquent payments received by Company subsequent to each Payment Due Date.
3. **Trade-In Equipment.** As consideration for the reduced Monthly Fee, Customer has agreed to convey to Company the Trade-In Equipment as set forth on the face sheet of this Agreement as of the date hereof. Customer represents and warrants that it is the sole owner of the Trade-In Equipment. Customer further represents and warrants that: (a) Customer has full authority to sell the Trade-In Equipment; (b) The Trade-In Equipment is not subject to any lease, security interest, or financing; (c) No hazardous materials are contained in or attached to the Trade-In Equipment beyond ordinary solid waste residue. By execution hereof, Customer hereby unconditionally sells and conveys to Company pursuant to the foregoing representations and warranties title to the Trade-In Equipment “as-is” without recourse. Should this Agreement be terminated for any reason, Customer shall have no right or claim to the Trade-In Equipment
4. **Agreement.** This document shall constitute a legally binding contract by and between Company and Customer and their respective heirs, successors, and assigns in accordance with the terms and conditions set forth herein. This Agreement contains the entire agreement of the parties relating to the Equipment and may not be changed, modified, terminated, or discharged, except in writing signed by both parties. Any other terms and conditions contained in Customer issued purchase orders, checks or other mediums shall be of no force nor shall they affect the rights and responsibilities of the parties hereto.
5. **Equipment.** “Equipment” means all the equipment described herein, and all replacements and accessories. Upon installation, Customer shall be responsible for all care, custody, and control of the Equipment during the Contract Term, subject to the terms and conditions in this Agreement. Customer acquires no ownership, title, or property rights or interest in the Equipment, except the right to use the same in accordance with and subject to the terms and conditions in this Agreement, and in compliance with any procedures and policies that Company may reasonably establish from time to time which are available at <https://compactorrentalsofamerica.com/service-guide/> and subject to change during the term of this Agreement at Company’s sole discretion; and Customer shall, at its expense, keep the Equipment free and clear from any and all claims, liens, encumbrances and legal processes of Customer’s creditors and other persons. Company shall have the right from time to time, during reasonable business hours, to enter upon the premises where the Equipment is located for the purpose of inspecting and servicing the Equipment, and Customer shall take all commercially reasonable actions, promptly upon Company’s request from time to time, to grant such access to Company.
6. **Maintenance; Return upon Contract Expiration.** Subject to the Customer’s responsibilities set forth in this Agreement, Company shall maintain the Equipment at its expense in good operating condition, and Company shall make all repairs and replacements necessary for the operation of the Equipment upon reasonable request by Customer, or at any time, on Company’s own schedule; *provided, however*, Customer shall pay on demand the costs of all repairs, replacement parts, and labor attributable to Customer’s failure abide by operational procedures set forth in Section 4 of this Agreement, rodent or pest infiltration causing damage to the Equipment or components thereof, abuse or negligent operation or care of the Equipment by Customer, its agents, or employees, as determined by Company in its sole discretion. Customer shall not alter or disfigure any of the Equipment or alter, modify or cover up any marks of identification supplied by Company. Customer shall not move or transport any of the Equipment from the location set forth in this Agreement without the prior written consent of Company, except that, upon the expiration of this Agreement at the end of a Contract Term in accordance with the terms of this Agreement, unless other arrangements are agreed upon by Company, Customer shall return the Equipment, freight pre-paid, to Company in good repair, condition, and working order, ordinary wear and tear excepted, in a manner and in a location designated by Company.
7. **Insurance.** At its own expense, Customer shall maintain (i) insurance against loss, theft, and damage to the Equipment, (ii) insurance to include special form coverage (all risk) for Equipment rented, leased, or borrowed, in amounts to insure for the full replacement cost of such Equipment, and (iii) insurance with respect to liability for bodily injury, including death and property damage resulting from the ownership, maintenance, use, or operation of the Equipment, each during the Contract Term, and thereafter, so long as the Equipment is on Customer's premises or under Customer’s control. All insurance shall be in form, amount, and with companies satisfactory to Company, and shall contain the insurer's agreement to give thirty (30) days written notice to Company before cancellation or material change of any policy of insurance. Customer shall furnish to Company, within five (5) days prior to the scheduled delivery of the Equipment, a satisfactory certificate of insurance provided by a company approved by Company which is in full force and effect before delivery of the Equipment. Upon Company's request, Customer shall deliver the policies or copies thereof or certificates of insurance to Company. In the event of an insurance policy cancellation or lapse threatened by reason of nonpayment of an insurance premium, Company may pay the charge on Customer's behalf, and subsequently charge the Customer accordingly. Company shall be shown as a loss payee or additional insured, as applicable, on a primary and non-contributing basis on the foregoing policies to the extent that its interests may appear and any proceeds payable pursuant to those policies shall be paid to all named insureds as their interests may appear.
8. **Equipment Damage Waiver.** At Customer’s option, or in the event the Customer fails to deliver the required property damage insurance certificates or policies to Company prior to delivery of the Equipment, Customer will be deemed to have accepted and shall pay for the Equipment Damage Waiver attached hereto. The Damage Waiver is not insurance and will only be in effect after Customer submits payment for the Equipment Damage Waiver charges. The Equipment Damage Waiver relieves Customer of financial responsibility to Company in excess of \$1,000 in the event that the Equipment is damaged due to act of god. The Equipment Damage Waiver is not total damage protection. If the Equipment is damaged due to neglect, vandalism, carelessness, or inadequate security, Customer is required to pay the cost of repairs regardless of whether the Customer purchased an Equipment Damage Waiver. Customer may cancel the Equipment Damage Waiver upon receipt by Company of the required insurance certificate. The Equipment Damage Waiver does not relieve Lessee of its obligation to provide liability insurance.
9. **Notice.** Customer hereby irrevocably authorizes Company to take any action it deems necessary or appropriate to provide public notice of the Company’s title and ownership interest in the Equipment. Customer authorizes the filing of this Agreement or one or more Uniform Commercial Code financing statements regarding the Equipment. This Agreement may be subject to the rights, liens, and security interests held by the Company’s secured lenders, and such rights, liens, and security interests may be reflected on one or more Uniform Commercial Code financing statements of record from time to time.

10. **Liability for Equipment.** Customer accepts responsibility for the Equipment and contents at all times except, as to the Equipment, when it is being physically handled by the employees or other representatives of Company. Customer, therefore, expressly agrees to defend, indemnify, and hold Company harmless from and against any and all liabilities, obligations, losses, damages, injuries, claims, demands, penalties, actions, costs and expenses of whatever kind and nature (including attorneys' fees) imposed on, incurred or asserted against Company in any way relating to or arising out of the use, condition, operation, maintenance, possession, rental or return of any of the Equipment. Customer shall promptly notify Company of any accident resulting from or relating to (or allegedly resulting from or relating to) the Equipment.
11. **Warranties.** Company makes no warranties, either express or implied concerning the Equipment, and Company expressly disclaims any warranty of merchantability or fitness for particular or trade use of the Equipment for any purpose or the like. Company does not warrant in any way the design, workmanship, quality, capacity, suitability of the Equipment, or its freedom from latent defects or patent infringement or its compliance with any contract, rule or law. Customer agrees to indemnify and hold harmless Company for loss of use due to machine maintenance, malfunction, or any other loss of use, including (without limitation) any expense incurred by Customer to procure alternative service while any portion of the Equipment is undergoing repair. Company has no liability whatsoever for any consequential or incidental damages, costs or expenses arising from the Equipment, its use or periods of inoperability.
12. **Taxes.** Customer shall be responsible for and shall pay any and all local, municipal, state, or federal taxes, license fees, assessments which are imposed or levied upon the Equipment during the Contract Term of this Agreement, including any extension thereof and shall save and hold Company harmless from all liability in connection therewith. Company shall not be liable for installation of utility service necessary to operate the Equipment, or any utility service charges attributable to the Equipment's operation.
13. **Events of Default.** Customer shall be in default under this Agreement upon the happening of any one or more of the following events or conditions (each, an "Event of Default"): (a) Customer defaults in the payment when due of any amount due under this Agreement, and such default continues for five (5) days; (b) Customer defaults in the performance of any other obligation or covenant contained in this Agreement, and such default continues for five (5) days after notice thereof is sent to Customer by Company; (c) the Equipment is lost, stolen, substantially damaged, destroyed, sold, encumbered, or made the subject of any levy, seizure or attachment with respect to Customer; (d) Customer abandons all or any part of the Equipment for a period in excess of five (5) days; (e) Customer defaults in the performance of any obligation or covenant contained in any other agreement or contract that Customer and Company are a party to and such default continues beyond any grace or cure period (if any) set forth in such other agreement or contract; or (f) a petition for relief under any chapter of Title 11 of the United States Code, as amended, is commenced by or against Customer; Customer makes a general assignment for the benefit of its creditors; Customer fails general to pay its debts as they become due; Customer ceases operating its business, ceases doing the type of business for which the equipment was intended to be used or ceases operating its business out of the "Customer Equipment Location" designated above; or a receiver is appointed for all or any part of Customer's property. Upon the occurrence and during the continuance of an Event of Default, Company may immediately terminate this Agreement, and upon any such termination, Customer shall (i) make the Equipment available to Company (or, at Company's option, Company may enter the premises where the Equipment is located to take possession and remove it or otherwise render it unusable without removing it from its location), and (ii) pay, as liquidated damages in a single sum, an amount equal to the Monthly Fee multiplied by the number of months remaining in the Contract Term at the time of such termination. If Customer breaches this Agreement, Customer acknowledges that Company will have incurred costs of acquiring the Equipment, and shall incur refurbishing and other costs, and from month to month, Company may incur costs in excess of the Monthly Fee. To that end, Customer agrees that the foregoing liquidated damages are intended to approximate Company's damage upon such breach and is not a penalty. Customer shall also pay all costs of recovering the Equipment and preparing the same for reletting or sale, and for all other costs of collection and enforcement, including reasonable attorneys' fees, incurred by Company after the occurrence and during the continuance of any Event of Default. Nothing herein is intended or shall be deemed to limit or impair Company's ability to pursue, in addition to the above-referenced remedies, any other remedy available to Company at law or in equity, including any other measure of damages resulting from Customer's default under the terms of this Agreement. In addition to the foregoing remedies and obligations, in the event of default the Company may also enter the premises where the Equipment is located to render the Equipment inoperable. Upon cure of the applicable event of default, the Customer cure obligations shall also include responsibility for the Company's expenses necessary to immobilize and restore the Equipment to operational status. In the event that Customer is unable to cure and this agreement is terminated, such expenses for immobilize the Equipment shall be an added damage recoverable by the Company in addition to its other rights and remedies contained herein.
14. **Governing Law; Arbitration.** The parties have entered into this Agreement in the State of Arizona. The parties agree that this Agreement shall be interpreted, construed and enforced in accordance with the internal laws of the State of Arizona, without giving effect to Arizona conflicts of law principles. In the event of any dispute regarding breach, interpretation or enforcement of this Agreement, the parties agree to submit the issue to binding arbitration in Arizona. Unless another procedure is mutually agreed upon, the rules of the American Arbitration Association shall apply. In the event that either party commences legal action to enforce the terms and conditions of this Agreement, the prevailing party shall be entitled to its costs of suit incurred therein, including but not limited to reasonable attorneys' fees. Notwithstanding the foregoing or anything else to the contrary in this Agreement, nothing herein is intended or shall be deemed to limit, restrict or otherwise impair the Company's ability to initiate and prosecute in any applicable jurisdiction actions related to the repayment and collection of amounts owing by Customer under this Agreement and the exercise of all of Company's rights against the Customer with respect to the Equipment.
15. **Miscellaneous.** Customer represents that the Equipment is rented for business purposes and under no circumstances shall this Agreement be deemed or construed as a consumer contract. Commencing one (1) year from the start date hereof, and thereafter for the duration of this Agreement, or any extension thereof, rental fees may be increased, by Company, to reflect market changes for the use of the Equipment This Agreement and the rights and obligations of the parties hereunder may be amended, changed or modified only in writing executed by both of the parties hereto.
16. **Construction.** If any provision of this Agreement shall contravene existing law in any jurisdiction where enforcement is sought, such provisions as contravene applicable law and only such provisions, shall be unenforceable, and the balance of this Agreement shall remain in full force and effect. This Agreement may be executed in one or more counterparts, each of which shall be deemed to be a duplicate original, but all of which, taken together, shall be deemed to constitute a single instrument. The parties agree that a facsimile or e-mailed "PDF" of an executed counterpart of this Agreement shall be deemed to constitute due and sufficient delivery of a duplicate of this Agreement.
17. **Jury Waiver.** EACH OF THE PARTIES, INCLUDING EVERY GUARANTOR, WAIVE ALL RIGHTS TO TRIAL BY JURY.
18. **Excused Performance.** Notwithstanding anything to the contrary herein, Company shall not be liable for its failure to perform hereunder due to contingencies beyond its reasonable control including, but not limited to, strike, riots, fires, and acts of God.

19. **Assignment.** Customer shall not assign this Agreement without the prior written consent of Company. Company may assign this Agreement without the Customer's consent.
20. **Credit Check.** Customer hereby authorizes release of all information, including credit information, contained in Customer's account file.
21. **Waste Material.** The waste material to be disposed of by Customer pursuant to this Agreement is solid waste generated by Customer, excluding radioactive, volatile, flammable, explosive, toxic or hazardous material. It is a material breach of this Agreement to utilize the Equipment to transport, store or process hazardous material. The term "Hazardous Material" shall include, but not be limited to, any amount of waste listed or characterized as hazardous by the United States Environmental Protection Agency or any state agency pursuant to the Resource Conservation and Recovery Act of 1976, as amended, or applicable state law. Title to and liability for any Hazardous Material shall remain with Customer and Customer expressly agrees to defend, indemnify, protect and hold harmless Company from and against and any all damages, penalties, fines and liabilities resulting from or arising out of such prohibited conduct.

CONTRACT DETAILS & TERMS AND CONDITIONS:

IN WITNESS WHEREOF, the parties have executed this Agreement.

Signature By: NAME TITLE
DATE _____

Signature By: NAME TITLE
DATE _____

Insurance for Rented Equipment and the Damage Waiver

As the Customer, you bear the entire risk of loss or damage to the rented equipment and its contents from any and every cause. In the event of loss or damage, you will be responsible for either repairing or replacing the equipment, or paying COMPANY the covered value of the equipment. No loss or damage shall relieve you of your financial obligations under the terms of your Lease, and any outstanding rent or fees will still be due in full.

You will be charged for the Damage Waiver unless you provide evidence of insurance prior to delivery of the Equipment. The Damage Waiver will be charged each month unless you decline the Damage Waiver in writing and you deliver a certificate of insurance from an insurance company acceptable to COMPANY showing that you have the following coverages and endorsements:

- (1) Coverage for loss of or damage to Equipment and Company must be named as the loss payee.
- (2) Comprehensive general liability insurance insuring both Company and Customer against loss. The general liability insurance amounts must be \$1,000,000 per occurrence. COMPANY must be named as an additional insured.
- (3) A waiver of Subrogation in favor of COMPANY for with respect to the general liability policy and coverage must be primary and non-contributory.

The Damage Waiver is NOT an insurance policy and does NOT cover your contents. The equipment damage waiver relieves you of your financial responsibility to COMPANY in excess of \$1,000 for rented Equipment in the event that the Equipment is damaged due act of god only.

Losses and Damage Not Covered by the Damage Waiver. COMPANY will not waive your liability under, but not limited to, the following circumstances:

- (1) Use or operation of the Equipment in a manner prohibited by or in breach of the rental agreement.
- (2) The unauthorized use or negligent or willful act of you, your employees or agents, improper use of the Equipment, overloading or improper load distribution, lack of maintenance or neglect of the Equipment.
- (3) Theft or loss of, or damage to, any Equipment contents.
- (4) Delivery, pickup or movement of Equipment.
- (5) Damage or loss to third parties.
- (6) Damage to a unit's components or fixtures.
- (7) Vandalism or malicious mischief, including graffiti.
- (8) Damage caused by any third party not expressly covered under the Damage Waiver, including but not limited to, damage caused by pest infiltration or trash haulers.
- (9) Damage waiver is not available to user sites located in CA, NY and FL.

Damage Waiver Fee per Month:

Waiver Fee Per Month

5% of Rental Rate

Agree to provide Insurance Certificate **Accept Damage Waiver**

Customer: [Click or tap here to enter text.](#)

Signature: _____

Name (Printed): _____

Title: _____

Date: _____





104

104

104



PURCHASE ORDER
29003

DANIEL BOONE HIGH SCHOOL
1440 Suncrest Drive
Gray, Tennessee 37615
423-477-1600

Date: 3-13-26

To: BSN sports

Ship To: DBHS
2000
Middle School 620/with bus

PART NUMBER	DESCRIPTION	QUANTITY ORDERED	PRICE	AMOUNT
	Middle School DB Uniforms			
	not to exceed \$11,000.00			
	TOTAL			

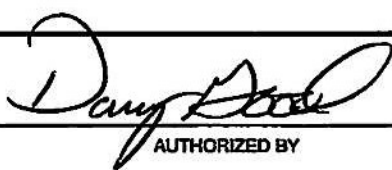
AUTHORIZED BY

PRICE INQUIRY FORM
Washington County Schools

Vendor	Description of item for price comparison	Price Quoted
Firm BSN Sports	MENS Football Pants 60 x \$4.50	\$ 3270.00
Address P.O. Box 841393 Dallas, Tx	MENS Football Top Home 60 x \$58.50 Away 60 x \$58.50	\$ 3510.00 \$ 3510.00
Person Contacted 1-423-383-1931 CJ LEE	Freight	\$ 54.50
Date 3-24-26	Total	\$ 10,884.50
Firm TEAM NIKE	MENS Football Pants 60 x \$65.00	\$ 3,900.00
Address Nike.com	MENS Football Top Home 60 x \$65.00 Away 60 x \$65.00	\$ 3,900.00 \$ 3,900.00
Person Contacted	No Freight	Q
Date 3-24-26	Total	\$ 11,700.00
Firm League Outfitters	MENS Football Pants 60 x \$52.00	\$ 3,120.00
Address 8220 Stanton Dr Jessup, MD	MENS Football Top Home 60 x \$90.00 Away 60 x \$90.00	\$ 5400.00 \$ 5400.00
Person Contacted 301-575-9400	No Freight	Q
Date 3-24-26	Total	\$ 13,920

Darryl Doan

Name of Person Obtaining Inquiry



Order Acknowledgment

Daniel Boone High School

Thanks for your order! Please verify the order details below and sign to confirm. You may email your approval or physically sign/fax your approval using my contact info below. Should you have any questions, please call me and I will answer them right away!

Thank your for the opportunity to service your account,

C.J. Lee

My Fax#: N/A

My Email: cjlee@bsnsports.com

Date: 3/24/26

Order/Cart #: e38c2986-36eb-4faf-t

Order Amt: \$10,804.50

Brief Product Description: Boone Middle School Football Uniforms

Expected Delivery Date: N/A

Invoice to be mailed on or after: 8/14/26

Invoice will be paid: Within 30 days of invoice Specified Date (if applicable): N/A

I confirm the order details for the goods and services indicated above are correct.

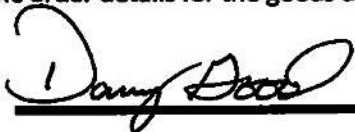
Signature: 

Date: 3-13-26

Payer Contact:

Payer Contact Title:

Payer Contact Email:

Payer Contact Phone:

Payer Account Name: Daniel Boone High School

Payer Acct #: 1432878

PURCHASING DEPARTMENT
WASHINGTON COUNTY BOARD OF EDUCATION

PURCHASE ORDER

Purchase Order **No 7718**

Date Issued **3/30/26**

Appropriation No. **141E71100722002**

Dept. **ISM**

School **Lamar - Donna Widner**

TO

Amitrace

Deliver to **Lamar Elementary**

Address **3261 Hwy 81 S**

Via **Jonesborough, TN 37659**

Articles on this order must be charged to account of

NOTICE TO VENDOR

1. Purchase order **MUST** bear two signatures in order to be valid.
2. Purchase order number **MUST** appear on all invoices submitted for payment.
3. Mail **TWO** copies of your invoice promptly to:

Washington County Board of Education
405 West College Street
Jonesborough, TN 37659
Telephone (423) 753-1105

ARTICLES OR SERVICES (Unless otherwise stated all prices F.O.B. Destination)	CODE	QUANTITY & UNIT	UNIT PRICE	TOTAL
VidPod Turnkey Video Podcast		1		
GRAND TOTAL - INCLUDING ALL ATTACHED PAGES				\$15,990⁰⁰

CJK
3/30/26

*** Quote attached ***
*** Sole Source letter attached ***

SUBJECT TO THE FOLLOWING CONDITIONS

1. All packages, cartons or other containers must be plainly marked with the purchase order number.
2. The right is reserved to purchase in the open market and to charge the difference to the Vendor in the event that deliveries are not made at the time specified in the bid and on this order.
3. Whenever a delivery is rejected, the Vendor shall be notified and be given the reason for the rejection. All rejected deliveries shall be held at the Vendor's risk and he shall bear the expense of removal.
4. Acceptance of this order includes acceptance of all terms, prices, delivery, instructions, specifications and conditions stated.
5. The county is not liable for Federal excise tax or state sales tax.
6. Each shipment and/or each purchase order should be covered by separate invoice.

IMPORTANT: INVOICES AND PACKAGES MUST BEAR PURCHASE ORDER NUMBER

VENDOR'S COPY

There is an otherwise unincumbered balance to the credit of the proper appropriation, allotment or fund to meet the expenditure covered by this purchase.

APPROVED:



Amitrace
8000 Miller Court E
Norcross, GA 30071
(770) 263-9190

VidPOD Quote

Washington County Board of Education
402 W College ST, Jonesborough,
14237531100

Delivery Information

Donna Widner
3261 Highway 81 South
Jonesborough, Tennessee, 37659
widnerd@wcde.org
14239463595

71100-722

Purchase Contract Type: None

Description	Quantity	Per Unit Price
VidPOD Turnkey Amitrace Video Podcast Includes 4 Podcast Microphones, 4 Headphones, Video & Audio Mixer, Podcast Table, 4 Microphone Booms Arms, Custom Mic Flags, 4K Monitor, 4 HD Cameras, CTAE Curriculum based on Georgia AVTF standards, virtual training, and virtual setup. (1-Year Warranty and Support Included)	1	\$14,995.00

Delivery Type:
Standard 60 Days, Continental US

Total: \$15,990.00

*Shipping price to be determined

Please email purchase order to sales@amitrace.com



December 15, 2025

To Whom It May Concern,

This letter serves to formally confirm that Amitrace Computer Systems, Inc. is the sole designer, developer, and manufacturer of the VidPod™ Podcast Studio System.

VidPod™ is a proprietary, turnkey podcast and video production solution developed by Amitrace to support K–12 and educational media programs. **VidPod™ is not available from any other manufacturer or systems integrator.**

The VidPod™ system is a fully integrated solution that includes proprietary elements such as:

- A uniquely designed podcast studio furniture and table configuration
- A proprietary system architecture and production workflow developed specifically for educational environments
- Proprietary instructional curriculum, training materials, and educator enablement resources

These components are designed and delivered as a single, unified system under the VidPod™ product offering. Amitrace retains exclusive rights to the design, configuration, implementation, and support of the VidPod™ system.

Because of this exclusivity, **no other vendor is authorized or capable of providing the VidPod™ Podcast Studio System**, nor can an alternative product be substituted without materially altering the scope, functionality, instructional outcomes, and long-term support of the solution.

Should you require additional information or clarification, please feel free to contact us directly.

Sincerely-

Faraz Ahmed
President | Amitrace
faraz@amitrace

PURCHASING DEPARTMENT
WASHINGTON COUNTY BOARD OF EDUCATION

Purchase Order **No 7783**

Date Issued **3/31/26**

Appropriation No. **141E-71100-449**

Dept. **Academics**

School **District**

PURCHASE ORDER

TO **Gallopade**

Deliver to **Cindy Hayes**
 Address **Washington County Warehouse**
306 1/2 Forest Dr.
 Via **Jonesborough, TN 37659**

Articles on this order must be charged to account of

NOTICE TO VENDOR

1. Purchase order **MUST** bear two signatures in order to be valid.
2. Purchase order number **MUST** appear on all invoices submitted for payment.
3. Mail **TWO** copies of your invoice promptly to:

Washington County Board of Education
 405 West College Street
 Jonesborough, TN 37659
 Telephone (423) 753-1105

ARTICLES OR SERVICES	CODE	QUANTITY & UNIT	UNIT PRICE	TOTAL
(Unless otherwise stated all prices F.O.B. Destination) TN 26-27 Gap Renewal See attached quote				
GRAND TOTAL - INCLUDING ALL ATTACHED PAGES				\$ 56,336.09

SUBJECT TO THE FOLLOWING CONDITIONS

1. All packages, cartons or other containers must be plainly marked with the purchase order number.
2. The right is reserved to purchase in the open market and to charge the difference to the Vendor in the event that deliveries are not made at the time specified in the bid and on this order.
3. Whenever a delivery is rejected, the Vendor shall be notified and be given the reason for the rejection. All rejected deliveries shall be held at the Vendor's risk and he shall bear the expense of removal.
4. Acceptance of this order includes acceptance of all terms, prices, delivery, instructions, specifications and conditions stated.
5. The county is not liable for Federal excise tax or state sales tax.
6. Each shipment and/or each purchase order should be covered by separate invoice.

IMPORTANT: INVOICES AND PACKAGES MUST BEAR PURCHASE ORDER NUMBER

VENDOR'S COPY

There is an otherwise unincumbered balance to the credit of the proper appropriation, allotment or fund to meet the expenditure covered by this purchase.

Authorized Signature

APPROVED:

Purchasing Agent



P.O. Box 2779, Peachtree City, GA 30269 • tel: 800-536-2438 • fax: 800-871-2979 • curriculum@gallopade.com

(TN) 26-27 GAP renewal. Washington County Schools. Grades 3-8. Bundled print/digital

Quote created February 4, 2026. Reference: 20260204-115848706

Washington County Schools TN

405 West college St

Jonesborough, TN 37659

Cindy Hayes

hayesc@wcde.org

423-753-1100

Comments

By 26-27 GAP renewal. Bundled print/digital

This quote is for the following number of teachers and students:

3rd: (568) Students, (22) Teacher Licenses

4th: (579) Students, (23) Teacher Licenses

5th: (556) Students, (22) Teacher Licenses

6th: (620) Students, (24) Teacher Licenses

7th: (610) Students, (24) Teacher Licenses

8th: (654) Students, (26) Teacher Licenses

For Teachers: digital teacher's edition, with a digital student book, access to Teaching Tools, Expertrack Testing & Analytics.

For Students: print book and interactive ebook. Access to assigned E-pertrack tests and assigned Teaching Tools

Shipping quoted is for a direct purchase. If purchased through Tennessee Book Company, shipping amount will differ.

Products & Services

Item & Description	SKU	Quantity & Price
<p>Tennessee 3rd Grade Print/Digital Bundle for 1 Student [1-Year Gap Pricing]</p> <p>Includes: · Student Workbook (print & digital) · ExperTrack Student · Digital Course Student</p> <p>978-0-635-14145-3</p>	TN3PSTIGY	568 x \$13.49
<p>Tennessee 4th Grade Print/Digital Bundle for 1 Student [1-Year Gap Pricing]</p> <p>Includes: · Student Workbook (print & digital) · ExperTrack Student · Digital Course Student</p> <p>978-0-635-14149-1</p>	TN4PSTIGY	579 x \$13.49
<p>Tennessee 5th Grade Print/Digital Bundle for 1 Student [1-Year Gap Pricing]</p> <p>Includes: · Student Workbook (print & digital) · ExperTrack Student · Digital Course Student</p> <p>978-0-635-14153-8</p>	TN5PSTIGY	556 x \$13.49
<p>Tennessee 6th Grade Print/Digital Bundle for 1 Student [1-Year Gap Pricing]</p> <p>Includes: · Student Workbook (print & digital) · ExperTrack Student · Digital Course Student</p> <p>978-0-635-14157-6</p>	TN6PSTIGY	620 x \$14.99
<p>Tennessee 7th Grade Print/Digital Bundle for 1 Student [1-Year Gap Pricing]</p> <p>Includes: · Student Workbook (print & digital) · ExperTrack Student · Digital Course Student</p> <p>978-0-635-14161-3</p>	TN7PSTIGY	610 x \$14.99

Item & Description	SKU	Quantity & Price
Tennessee 8th Grade Print/Digital Bundle for 1 Student [1-Year Gap Pricing]	TN8PSTIGY	654 x \$14.99
Includes: · Student Workbook (print & digital) · ExperTrack Student · Digital Course Student 978-0-635-14165-1		

One-time subtotal	\$51,214.63
shipping 10%	\$5,121.46
	10% fee
Total	\$56,336.09

This quote expires on August 3, 2026

- Digital licenses expire on June 30 of the final year listed on this quote above.
- Any shipping included in the quote is for shipping to a single district location.
- Quoted price is for a full single payment.
- This quote is priced, as requested, in its entirety and cannot be itemized or subdivided.
- If there is any change in number of students, grades involved, or duration of purchase, then a new quote must be provided.
- Training is included for any curriculum with digital access in this price for no additional fee. That includes initial training each year, live chat, 24/7 online module support, and a personal connection with your trainer.

Questions? Contact me



Vivian Bernstein

Curriculum Consultant

vivian@gallopade.com

+14703443118

PURCHASING DEPARTMENT
WASHINGTON COUNTY BOARD OF EDUCATION

PURCHASE ORDER

Purchase Order **No 7782**

Date Issued **3/31/26**

Appropriation No. **141E-71100-449**

Dept. **Academics**

School **District**

TO **SAVVAS**

NOTICE TO VENDOR

1. Purchase order **MUST** bear two signatures in order to be valid.
2. Purchase order number **MUST** appear on all invoices submitted for payment.
3. Mail **TWO** copies of your invoice promptly to:

Washington County Board of Education
 405 West College Street
 Jonesborough, TN 37659
 Telephone (423) 753-1105

Deliver to **Cindy Hayes**
 Address **Washington Co School District**
 Via **306 1/2 Forest DR**
Jonesborough, TN 37659

Articles on this order must be charged to account of

ARTICLES OR SERVICES	CODE	QUANTITY & UNIT	UNIT PRICE	TOTAL
(Unless otherwise stated all prices F.O.B. Destination)				
Science Adoption Additional High School Biology Foundations workbooks 8-year subscription ISBN # 9798213482645 See Quote Q-232933				
GRAND TOTAL - INCLUDING ALL ATTACHED PAGES			\$	33,288

SUBJECT TO THE FOLLOWING CONDITIONS

1. All packages, cartons or other containers must be plainly marked with the purchase order number.
2. The right is reserved to purchase in the open market and to charge the difference to the Vendor in the event that deliveries are not made at the time specified in the bid and on this order.
3. Whenever a delivery is rejected, the Vendor shall be notified and be given the reason for the rejection. All rejected deliveries shall be held at the Vendor's risk and he shall bear the expense of removal.
4. Acceptance of this order includes acceptance of all terms, prices, delivery, instructions, specifications and conditions stated.
5. The county is not liable for Federal excise tax or state sales tax.
6. Each shipment and/or each purchase order should be covered by separate invoice.

IMPORTANT: INVOICES AND PACKAGES MUST BEAR PURCHASE ORDER NUMBER

VENDOR'S COPY

There is an otherwise unincumbered balance to the credit of the proper appropriation, allotment or fund to meet the expenditure covered by this purchase.

Authorized Signature

APPROVED:

Purchasing Agent



Washington Co School District
Quote Number Q-232933

15 E Midland Ave St 502
Paramus, NJ, 07652-2938

Cindy Hayes
Washington Co School District
405 W College St
Jonesborough, TN 37659-1009

Quote Creation Date: 3/31/2026
Quote Expiration Date: 9/30/2026

Washington Co HS BIO extra Foundations Workbooks multi-year subscription
Price Quote Summary

Solution	Base Amount	Total
Miller Levine Biology	\$30,400.00	\$30,400.00
Solution Subtotal:	\$30,400.00	\$30,400.00

Shipping and Handling:	\$2,888.00
Total:	\$33,288.00



Washington Co School District
Quote Number Q-232933

15 E Midland Ave St 502
Paramus, NJ, 07652-2938

Price Quote Detail

Miller Levine Biology

Miller Levine Biology - Miller & Levine Biology for Tennessee \$2026

ISBN	Description	Price	Charged Qty	Total Charged
9798213482645	MILLER LEVINE BIOLOGY 2026 TENNESSEE FOUNDATIONS WORKBOOK 8-YEAR SUBSCRIPTION GRADE 9/12	\$152.00	200	\$30,400.00
Miller Levine Biology - Miller & Levine Biology for Tennessee \$2026 - Subtotal:				\$30,400.00

Solution Subtotal:	\$30,400.00
Shipping and Handling:	\$2,888.00
Total:	\$33,288.00



Washington Co School District
Quote Number Q-232933

15 E Midland Ave St 502
Paramus, NJ, 07652-2938

Savvas Learning Company LLC Terms and Conditions

To place your order please submit a copy of this price quote with your Purchase Order, include the Quote Number on your Purchase Order, and include any other required documentation. You may send the order documents using an electronic form or by mail. Please submit your PO and price quote via one of the following methods:

Online:

<https://support.savvas.com/support/s/customerserviceus>

Mail: PO Box 6620, Chandler, AZ 85246

Savvas does not accept Credit Card information via postal mail, facsimile, or email. Credit Card information will only be accepted via phone, eCommerce, or my Savvas Orders. For questions regarding your order please call Customer Service: 1-800-848-9500.

Price quote: This is a price quote for the customer's convenience only, and not an offer to contract. All quotes are subject to review and final acceptance by an authorized representative of Savvas at its offices. Savvas reserves the right to correct typographical, computational or other errors. Savvas' standard payment terms are net 30 days unless otherwise specified. All pricing is in US Dollars unless otherwise specified. Pricing calculations use multiple decimal places to determine the most accurate extended pricing but are represented in standard currency format.

Shipping & handling charges (where applicable) are shown on the quote. S&H rates quoted are for standard ground transportation and may not reflect account contracted rates. If expedited shipping is requested, actual charges may be higher. For orders picked up at the Savvas warehouse by the customer or a third party carrier contracted by the customer, a 2% handling charge will be applied to shippable items. The 2% charge will appear on the customer proposal and invoice as a S&H charge.

Taxes: All pricing in this quote is exclusive of any applicable sales, use or other similar taxes or duties. The customer is responsible for any such taxes or duties that may apply; if the customer is tax exempt, evidence of such tax exemption must be provided. Estimated tax may be provided solely for customer convenience. The amount indicated is only an estimate and is intended to be helpful for budgeting purposes. The actual amount of sales tax assessed at the time of invoicing may be more or less.

Platforms: Savvas, and any third party for which Savvas serves as the sales agent or distributor, reserve the right to change and/or update technology platforms, including possible edition updates to customers during the term of access. Customers will be notified of any change prior to the beginning of the new school year.

Damaged & Defective Products: If a print product, or the print component of a blended (print & digital) product, is received in damaged or defective condition, Savvas will issue a credit or replacement at no charge to the customer if the customer promptly (no later than 120 days) returns the damaged or defective product. Customers must report missing product immediately upon receipt.

Return Policy: Returns (other than damaged or defective products) are subject to the following conditions: (a) materials must be returned to Savvas at the customer's expense in new, unused condition, suitable for resale by Savvas (note that any barcoding, stickering, stamping or similar marking on any print materials renders them unsuitable for resale); (b) materials must be returned within six (6) months from the date of purchase; (c) the customer must obtain a Return Materials Authorization ("RMA") from Savvas prior to returning the materials, and must ship the materials back to Savvas within thirty days of receiving the RMA; (d) all materials sold in a set or package must be returned complete as originally sold; and (e) any materials provided by Savvas to the customer on a no-charge basis in consideration of the customer's purchase must be returned in proportion to the purchased materials that are being returned for a credit. A restocking fee of 3% may be applied to credits over \$1,000. Savvas' return policy does not apply to science lab kits or trade publication novels, which are sold on a non-returnable basis.

Consumable Worktexts: Subsequent year consumable worktexts will ship each year on the anniversary of the original order date for the duration of their license. Worktexts will ship to the location listed on the original order. Quantities for each grade level and title will remain consistent each year. Changes to quantities of titles previously ordered, shipping location changes, or any other changes to consumable worktext shipments must be made 4 weeks prior to shipment date. (the anniversary of the original order date unless changed). Changes can be made on the Subscription Worktext Site: <https://worktext-subscriptions.savvas.com>

Annual subscriptions for iLit and Successmaker Only: Savvas' iLit and Successmaker products (and no others) automatically renew on the anniversary date of the original purchase and will be invoiced accordingly unless otherwise specified. If you wish to cancel, please let us know in writing prior to the date of renewal by completing the customer service request form which you can access here: <https://support.savvas.com/support/s/customer-service-support-form>

Technical support services are included with purchase of Savvas digital products. **Online help:** <https://support.savvas.com/support/s/k12-curriculum-support-form>
phone: 1-800-848-9500

Professional Services: All paid services must be delivered within twelve (12) months of the order date of those services. Any unused services expire at the end of such twelve (12) month period, unless otherwise specified in contract terms. Any cancellation made with less than 72 hours' notice will result in a cancellation fee equal to the full price of the event. MySavvasTraining is included with purchase of products
<https://mysavvastraining.com>

PURCHASING DEPARTMENT
WASHINGTON COUNTY BOARD OF EDUCATION

Purchase Order **Nº 7652**

Date Issued **3/16/26**

Appropriation No. **141ET1300429002**

Dept. **15M#141ET1169722002**

School **Lamar - Donna Widner**

PURCHASE ORDER

NOTICE TO VENDOR

1. Purchase order **MUST** bear two signatures in order to be valid.
2. Purchase order number **MUST** appear on all invoices submitted for payment.
3. Mail **TWO** copies of your invoice promptly to:

Washington County Board of Education
 405 West College Street
 Jonesborough, TN 37659
 Telephone (423) 753-1105

TO

Presentation Solutions

Deliver to

Lamar Elementary

Address

3261 Hwy 81 S

Via

Jonesborough, TN 37659

Articles on this order must be charged to account of

ARTICLES OR SERVICES (Unless otherwise stated all prices F.O.B. Destination)	CODE	QUANTITY & UNIT	UNIT PRICE	TOTAL
<p>Please see attached quote</p> <p>* Buy Board Contract # 76025</p>				
GRAND TOTAL - INCLUDING ALL ATTACHED PAGES				\$19,058⁶¹

SUBJECT TO THE FOLLOWING CONDITIONS

1. All packages, cartons or other containers must be plainly marked with the purchase order number.
2. The right is reserved to purchase in the open market and to charge the difference to the Vendor in the event that deliveries are not made at the time specified in the bid and on this order.
3. Whenever a delivery is rejected, the Vendor shall be notified and be given the reason for the rejection. All rejected deliveries shall be held at the Vendor's risk and he shall bear the expense of removal.
4. Acceptance of this order includes acceptance of all terms, prices, delivery, instructions, specifications and conditions stated.
5. The county is not liable for Federal excise tax or state sales tax.
6. Each shipment and/or each purchase order should be covered by separate invoice.

IMPORTANT: INVOICES AND PACKAGES MUST BEAR PURCHASE ORDER NUMBER

VENDOR'S COPY

There is an otherwise unincumbered balance to the credit of the proper appropriation, allotment or fund to meet the expenditure covered by this purchase.

Authorized Signature

APPROVED:

Purchasing Agent

Quote

PRESENTATION SOLUTIONS
 PO BOX 159
 4809 FOX RUN ROAD
 BUCKNER, KY 40010
 (502) 222-7277

Order Number: 0094344
Order Date: 3/13/2026

Salesperson: DIV 70
Customer Number: 00-WASHTN

Sold To:

Washington County Board of Education
 ACCOUNTS PAYABLE
 405 West College St
 Jonesborough, TN 37659

Ship To:

Lamar Elementary School
 Donna Widner
 3261 Hwy 81 S
 Jonesborough, TN 37659

Confirm To:

Customer P.O.	Ship VIA	F.O.B.	Terms			
QUOTE	UPS GROUND		NET 10			
Item Number	Unit	Ordered	Shipped	Back Order	Price	Amount
UL-STDBOND-24 ColorPro 24" Standard Bond Pap	EACH	8	0	0	79.15	633.20
			Whse: 000			
UL-STDBOND-36 36" Standard Bond Paper, 36"x1	EACH	8	0	0	98.95	791.60
			Whse: 000			
UL-IOV-24 Stadium Pro Indoor/Outdoor Vin	EACH	5	0	0	178.15	890.75
			Whse: 000			
UL-IOV-36 Stadium Pro Indoor/Outdoor Vin	EACH	5	0	0	257.35	1,286.75
			Whse: 000			
UL-WLSVR-36 Wall-Friendly Adhesive Vinyl,	EACH	4	0	0	445.45	1,781.80
			Whse: 000			
Special Promotion #1: Purchase 10 rolls of ColorPro paper, receive 1 roll of standard bond paper free!						
UL-STDBOND-24 ColorPro 24" Standard Bond Pap	EACH	3	0	0	0.00	0.00
			Whse: 000			
UL-MAINCART Maintenance Cartridge For Colo	EACH	1	0	0	148.50	148.50
			Whse: 000			
UL-PH6 Printhead For ColorPro ULTRA	EACH	1	0	0	643.50	643.50
			Whse: 000			
UL2-INKSET-301 ColorPro Ultra 2 Full Ink Set	EACH	3	0	0	1,088.75	3,266.25
			Whse: 000			
Special Promotion #2: Purchase 10 ColorPro inks, receive 1 roll of standard bond paper free!						
UL-STDBOND-24 ColorPro 24" Standard Bond Pap	EACH	1	0	0	0.00	0.00
			Whse: 000			
CL-FILM-300 CoolLam Dual-Sided Laminating	EACH	2	0	0	296.95	593.90
			Whse: 000			
/ITEM UL-STADIUM-36	EACH	3	0	0	1,282.05	3,846.15
Stadium/Gym Posters Starter Kit includes the following items.						

722

722

Continued

Quote

PRESENTATION SOLUTIONS
 PO BOX 159
 4809 FOX RUN ROAD
 BUCKNER, KY 40010
 (502) 222-7277

Order Number: 0094344
Order Date: 3/13/2026

Salesperson: DIV 70
Customer Number: 00-WASHTN

Sold To:
 Washington County Board of Education
 ACCOUNTS PAYABLE
 405 West College St
 Jonesborough, TN 37659
Confirm To:

Ship To:
 Lamar Elementary School
 Donna Widner
 3261 Hwy 81 S
 Jonesborough, TN 37659

Customer P.O.	Ship VIA	F.O.B.	Terms			
QUOTE	UPS GROUND		NET 10			
Item Number	Unit	Ordered	Shipped	Back Order	Price	Amount
UL-IOV-36	EACH	12	0	0	0.00	0.00
Stadium Pro Indoor/Outdoor Vin			Whse: 000			
UL-BANTABS	EACH	6	0	0	0.00	0.00
Banner Tabs, Pack of 100			Whse: 000			
UL-PUNCH	EACH	3	0	0	0.00	0.00
Banner Tabs, Punch			Whse: 000			
ID-TAPE-110C	EACH	3	0	0	89.05	267.15
ID/Recog 4" Tape, Clear, 1 rol			Whse: 000			
ID-TAPE-111BK	EACH	3	0	0	89.05	267.15
ID/Recog 4" Tape, Black, 1 rol			Whse: 000			
ID-TAPE-112W	EACH	4	0	0	89.05	356.20
ID/Recog 4" Tape, White, 1 rol			Whse: 000			
ID-RIB-101BK	EACH	2	0	0	148.45	296.90
ID/Recog 4" Ribbon-Black (each			Whse: 000			
ID-RIB-102WH	EACH	2	0	0	148.45	296.90
ID/Recog 4" Ribbon-White (each			Whse: 000			
ID-RIB-103RD	EACH	2	0	0	148.45	296.90
ID/Recog 4" Ribbon-Red (each)			Whse: 000			
ID-RIB-104BL	EACH	2	0	0	148.45	296.90
ID/Recog 4" Ribbon-Blue (each)			Whse: 000			
ID-RIB-105NB	EACH	2	0	0	148.45	296.90
ID/Recog 4" Ribbon-Navy Blue (Whse: 000			
ID-RIB-106DG	EACH	2	0	0	148.45	296.90
ID/Recog 4" Ribbon-Dark Green			Whse: 000			
ID-RIB-107GR	EACH	2	0	0	148.45	296.90
ID/Recog 4" Ribbon-Green (each			Whse: 000			
ID-RIB-108YW	EACH	2	0	0	148.45	296.90
ID/Recog 4" Ribbon-Yellow (eac			Whse: 000			

Continued

Quote

PRESENTATION SOLUTIONS
PO BOX 159
4809 FOX RUN ROAD
BUCKNER, KY 40010
(502) 222-7277

Order Number: 0094344
Order Date: 3/13/2026

Salesperson: DIV 70
Customer Number: 00-WASHTN

Sold To:
Washington County Board of Education
ACCOUNTS PAYABLE
405 West College St
Jonesborough, TN 37659
Confirm To:

Ship To:
Lamar Elementary School
Donna Widner
3261 Hwy 81 S
Jonesborough, TN 37659

Customer P.O.	Ship VIA	F.O.B.	Terms			
QUOTE	UPS GROUND		NET 10			
Item Number	Unit	Ordered	Shipped	Back Order	Price	Amount
ID-RIB-109OR	EACH	2	0	0	148.45	296.90
ID/Recog 4" Ribbon-Orange (eac			Whse: 000			
/ITEM	EACH	1	0	0	1,183.05	1,183.05

2 Year Extended Warranty
ColorPro Ultra XL 2 machine purchased 3/13/26.

Net Order:	18,628.05
Less Discount:	0.00
Freight:	430.56
Sales Tax:	0.00
Order Total:	19,058.61

722

PURCHASING DEPARTMENT
WASHINGTON COUNTY BOARD OF EDUCATION

Purchase Order **No 7788**

Date Issued **3/31/26**

Appropriation No. **141E-71100-449**

Dept. **Academics**

School **District**

PURCHASE ORDER

TO
Benchmark Education

NOTICE TO VENDOR

1. Purchase order **MUST** bear two signatures in order to be valid.
2. Purchase order number **MUST** appear on all invoices submitted for payment.
3. Mail **TWO** copies of your invoice promptly to:

Washington County Board of Education
 405 West College Street
 Jonesborough, TN 37659
 Telephone (423) 753-1105

Deliver to **Cindy Hayes**
 Address **306 1/2 Forest Dr**
 Via **Jonesborough, TN 37659**

Articles on this order must be charged to account of

ARTICLES OR SERVICES	CODE	QUANTITY & UNIT	UNIT PRICE	TOTAL
(Unless otherwise stated all prices F.O.B. Destination)				
Quote # 89000 Renewal - 3 years (Fap Years) 26-27 27-28 28-29				
GRAND TOTAL - INCLUDING ALL ATTACHED PAGES				\$ 427,360.20

SUBJECT TO THE FOLLOWING CONDITIONS

1. All packages, cartons or other containers must be plainly marked with the purchase order number.
2. The right is reserved to purchase in the open market and to charge the difference to the Vendor in the event that deliveries are not made at the time specified in the bid and on this order.
3. Whenever a delivery is rejected, the Vendor shall be notified and be given the reason for the rejection. All rejected deliveries shall be held at the Vendor's risk and he shall bear the expense of removal.
4. Acceptance of this order includes acceptance of all terms, prices, delivery, instructions, specifications and conditions stated.
5. The county is not liable for Federal excise tax or state sales tax.
6. Each shipment and/or each purchase order should be covered by separate invoice.

IMPORTANT: INVOICES AND PACKAGES MUST BEAR PURCHASE ORDER NUMBER

VENDOR'S COPY

There is an otherwise unincumbered balance to the credit of the proper appropriation, allotment or fund to meet the expenditure covered by this purchase.

Authorized Signature

APPROVED:

Purchasing Agent

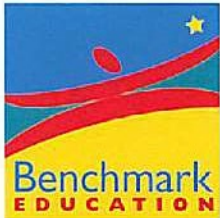

**BENCHMARK
EDUCATION
COMPANY**
145 Huguenot Street, 8th Floor
New Rochelle, New York 10801

Contact representative
E02081 Angie Templeton
Email: atempleton@benchmarkeducation.com
Office Phone:
Phone: 615-679-8020

QUOTE: 89000

Customer:

Sabrina St. John, Special Education Coordinator
Washington County Schools Board of Education
2002 Indian Ridge Road
Johnson City TN 37602

Ship To:

Melinda Carr, Instructional Supervisor
Washington County Warehouse
306 1/2 Forest Drive
Jonesborough TN 37659

ISBN	Title	Price Level	Unit Price	Qty	Total Price
X149546R	Benchmark Advance 2021 (Tennessee Edition) Gr. K Teacher Digital Renewal Subscription	3-Year	\$460.00	26	\$11,960.00
Discount (100%)	* Teacher Digital proved as Gratis with Student Subscriptions				(\$11,960.00)
X149547R	Benchmark Advance 2021 (Tennessee Edition) Gr. 1 Teacher Digital Renewal Subscription	3-Year	\$460.00	29	\$13,340.00
Discount (100%)	* Teacher Digital proved as Gratis with Student Subscriptions				(\$13,340.00)
X149548R	Benchmark Advance 2021 (Tennessee Edition) Gr. 2 Teacher Digital Renewal Subscription	3-Year	\$495.00	28	\$13,860.00
Discount (100%)	* Teacher Digital proved as Gratis with Student Subscriptions				(\$13,860.00)
X149549R	Benchmark Advance 2021 (Tennessee Edition) Gr. 3 Teacher Digital Renewal Subscription	3-Year	\$495.00	23	\$11,385.00
Discount (100%)	* Teacher Digital proved as Gratis with Student Subscriptions				(\$11,385.00)
X149550R	Benchmark Advance 2021 (Tennessee Edition) Gr. 4 Teacher Digital Renewal Subscription	3-Year	\$495.00	14	\$6,930.00
Discount (100%)	* Teacher Digital proved as Gratis with Student Subscriptions				(\$6,930.00)
X149551R	Benchmark Advance 2021 (Tennessee Edition) Gr. 5 Teacher Digital Renewal Subscription	3-Year	\$495.00	12	\$5,940.00
Discount (100%)	* Teacher Digital proved as Gratis with Student Subscriptions				(\$5,940.00)
X149553R	Benchmark Advance 2021 (Tennessee Edition) Gr. K Student Digital Renewal Subscription	3-Year	\$61.55	460	\$28,313.00

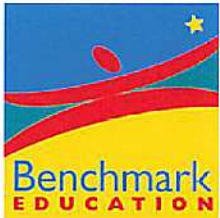

**BENCHMARK
EDUCATION
COMPANY**
145 Huguenot Street, 8th Floor
New Rochelle, New York 10801

Contact representative
E02081 Angie Templeton
Email: atempleton@benchmarkeducation.com
Office Phone:
Phone: 615-679-8020

QUOTE: 89000

ISBN	Title	Price Level	Unit Price	Qty	Total Price
X149554R	Benchmark Advance 2021 (Tennessee Edition) Gr. 1 Student Digital Renewal Subscription	3-Year	\$61.55	527	\$32,436.85
X149555R	Benchmark Advance 2021 (Tennessee Edition) Gr. 2 Student Digital Renewal Subscription	3-Year	\$58.95	581	\$34,249.95
X149556R	Benchmark Advance 2021 (Tennessee Edition) Gr. 3 Student Digital Renewal Subscription	3-Year	\$58.95	556	\$32,776.20
X149557R	Benchmark Advance 2021 (Tennessee Edition) Gr. 4 Student Digital Renewal Subscription	3-Year	\$58.95	604	\$35,605.80
X149558R	Benchmark Advance 2021 (Tennessee Edition) Gr. 5 Student Digital Renewal Subscription	3-Year	\$58.95	592	\$34,898.40
9781667718705	Benchmark Advance 2021 (National Edition) Gr. K My Reading and Writing Units 1-10 1-Copy Set Consumables 3-Year	Current	\$69.00	460	\$31,740.00
9781667718729	Benchmark Advance 2021 (National Edition) Gr. 1 My Reading and Writing Units 1-10 1-Copy Set Consumables 3-Year	Current	\$69.00	527	\$36,363.00
9798331814496	Benchmark Advance 2021 (National Edition) Gr. 2 Text for Close Reading Units 1-10 1-Copy Consumables 3-Year	Current	\$69.00	581	\$40,089.00
9798331814502	Benchmark Advance 2021 (National Edition) Gr. 3 Text for Close Reading Units 1-10 1-Copy Consumables 3-Year	Current	\$69.00	556	\$38,364.00
9798331814519	Benchmark Advance 2021 (National Edition) Gr. 4 Text for Close Reading Units 1-10 1-Copy Consumables 3-Year	Current	\$69.00	604	\$41,676.00
9798331814526	Benchmark Advance 2021 (National Edition) Gr. 5 Text for Close Reading Units 1-10 1-Copy Consumables 3-Year	Current	\$69.00	592	\$40,848.00

Subtotal	Discount / Gratis Product Total	Sales Tax	Shipping Cost	Total
\$490,775.20	(\$63,415.00)	\$0.00	\$0.00	\$427,360.20 USD

Memo

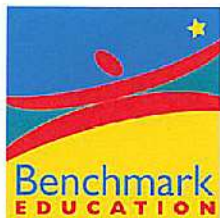

**BENCHMARK
EDUCATION
COMPANY**

145 Huguenot Street, 8th Floor
New Rochelle, New York 10801

Contact representative

E02081 Angie Templeton

Email: atempleton@benchmarkeducation.com

Office Phone:

Phone: 615-679-8020

QUOTE: 89000

* This estimate is valid until 8/1/2026 * Three Year Renewal Estimate: Subscriptions to span 7/31/2026 - 7/31/2029 * Gratis shipping and handling as per contract.

* The above pricing cannot be combined with any other offers.

* Price firm for 45 days from quote date. Price quote must be attached to school purchase orders to receive the quoted price.

* All digital subscriptions will end on July 31st the last year of the term purchased.

* Any changes, including cancellations to the originally agreed upon PD trainings, must be made at least 10 business days prior to the delivery of the PD trainings. Customized PD changes must be submitted at least 15 business days prior to agreed delivery date and must go through the customized request process. Benchmark Education will do its best to accommodate the requested changes; however, it reserves the right to render services according to the initial agreement. Please note that any changes requested may incur an additional charge or reduction of number of PD training days rendered. Please note that no changes can be requested on site and all requests must go through the Company approval process.

PURCHASING DEPARTMENT
WASHINGTON COUNTY BOARD OF EDUCATION

Purchase Order **No 7785**

Date Issued **3/31/26**

Appropriation No. **141E-71100-449**

Dept. **Academics**

School **District**

PURCHASE ORDER

TO **Magma Math**

Deliver to **Cindy Hayes**
 Address **(same)**

Via

Articles on this order must be charged to account of

NOTICE TO VENDOR

1. Purchase order **MUST** bear two signatures in order to be valid.
2. Purchase order number **MUST** appear on all invoices submitted for payment.
3. Mail **TWO** copies of your invoice promptly to:

Washington County Board of Education
 405 West College Street
 Jonesborough, TN 37659
 Telephone (423) 753-1105

ARTICLES OR SERVICES	CODE	QUANTITY & UNIT	UNIT PRICE	TOTAL
(Unless otherwise stated all prices F.O.B. Destination)				
Renewal See Quote 5427 Year 2				
GRAND TOTAL - INCLUDING ALL ATTACHED PAGES				76,720

SUBJECT TO THE FOLLOWING CONDITIONS

1. All packages, cartons or other containers must be plainly marked with the purchase order number.
2. The right is reserved to purchase in the open market and to charge the difference to the Vendor in the event that deliveries are not made at the time specified in the bid and on this order.
3. Whenever a delivery is rejected, the Vendor shall be notified and be given the reason for the rejection. All rejected deliveries shall be held at the Vendor's risk and he shall bear the expense of removal.
4. Acceptance of this order includes acceptance of all terms, prices, delivery, instructions, specifications and conditions stated.
5. The county is not liable for Federal excise tax or state sales tax.
6. Each shipment and/or each purchase order should be covered by separate invoice.

IMPORTANT: INVOICES AND PACKAGES MUST BEAR PURCHASE ORDER NUMBER

VENDOR'S COPY

There is an otherwise unincumbered balance to the credit of the proper appropriation, allotment or fund to meet the expenditure covered by this purchase.

Authorized Signature

APPROVED:

Purchasing Agent

Magma Math Subscription Agreement

Quote created: February 25, 2025 Reference: 20250225-112547565

TN-SD WASHINGTON COUNTY

405 W College ST
Jonesborough, TN 37659
US

Cindy Hayes

Chief Academic Officer
hayesc@wcde.org
423-753-1100

Josh Davis

Deputy Chief Academic Officer
davisj2@wcde.org
423-753-1100

Jerry Boyd

Superintendent
boydj@wcde.org
423-753-1100

Comments

4,795 Student Licenses
3 Year Contract
Annual Payments

Chad Shilstone - Education Executive Radish Education Inc



Products & Services

Item & Description	Quantity	Unit Price	Total
Magma Math Partial District Subscription Student License	4,795	\$16.00 / year	\$76,720.00 / year for 3 years

Annual subtotal	\$76,720.00
Total	\$76,720.00
Total contract value	\$230,160.00

Signature

Signature

Date

Printed name

Countersignature

Countersignature

Date

Printed name

This quote expires on June 30, 2025

Terms, agreements & documents

Subscription period

The subscription start date is September 1, 2025.

The subscription end date is August 31, 2028.

Tax

All prices listed exclude taxes. If your organization holds a valid tax exemption certificate, please submit it to chad@magnamath.com for verification and processing.

Payment terms

Please issue all Purchase Orders to Radish Education Inc.

We accept payment via ACH or check. Detailed payment information is provided on the invoice. Net 30 days from Invoice Date.

Additional Agreements and documents

Our W-9 form can be found [here](#).

By signing this quote, you are, on behalf of your organization, agreeing to our [Privacy Policy](#) and [Terms of Use](#).

Questions? Contact me



Chad Shilstone

Education Executive
chad@magnamath.com

Radish Education Inc

470 RAMONA STREET
Palo Alto CA 94301
United States

PURCHASING DEPARTMENT
WASHINGTON COUNTY BOARD OF EDUCATION

Purchase Order **№ 7784**

Date Issued **3/31/26**

Appropriation No. **141E-71100-449**

Dept. **Academics**

School **District**

PURCHASE ORDER

TO **Code HS**

Deliver to **William Stepp**

Address **(same)**

Via

Articles on this order must be charged to account of

NOTICE TO VENDOR

1. Purchase order **MUST** bear two signatures in order to be valid.
2. Purchase order number **MUST** appear on all invoices submitted for payment.
3. Mail **TWO** copies of your invoice promptly to:

Washington County Board of Education
 405 West College Street
 Jonesborough, TN 37659
 Telephone (423) 753-1105

ARTICLES OR SERVICES	CODE	QUANTITY & UNIT	UNIT PRICE	TOTAL
(Unless otherwise stated all prices F.O.B. Destination)				
Code HS See attached Quote #33420 Computer Science				
GRAND TOTAL - INCLUDING ALL ATTACHED PAGES				\$ 22,225.00

SUBJECT TO THE FOLLOWING CONDITIONS

1. All packages, cartons or other containers must be plainly marked with the purchase order number.
2. The right is reserved to purchase in the open market and to charge the difference to the Vendor in the event that deliveries are not made at the time specified in the bid and on this order.
3. Whenever a delivery is rejected, the Vendor shall be notified and be given the reason for the rejection. All rejected deliveries shall be held at the Vendor's risk and he shall bear the expense of removal.
4. Acceptance of this order includes acceptance of all terms, prices, delivery, instructions, specifications and conditions stated.
5. The county is not liable for Federal excise tax or state sales tax.
6. Each shipment and/or each purchase order should be covered by separate invoice.

IMPORTANT: INVOICES AND PACKAGES MUST BEAR PURCHASE ORDER NUMBER

VENDOR'S COPY	There is an otherwise unincumbered balance to the credit of the proper appropriation, allotment or fund to meet the expenditure covered by this purchase.	APPROVED:
	Authorized Signature	



Quote #33420

William Stepp
Washington County
405 W College Street
Jonesborough, TN 37659
USA

Order Summary

Start Date	07/01/2026	Total Amount	\$22,225.00
End Date	06/30/2027	Billing Frequency	Annual
Term	12 months	Payment Method	Check, Bank Transfer
Payment Terms	Net 30	Auto Renewal	No
Currency	USD	Integrations	Canvas LTI 1.3/LTI Advantage

Pricing Summary

Items	Start Date	End Date	Quantity	Price	Total Price
Pro Teacher License HS (District)	07/01/2026	06/30/2027	5	\$3,750.00	\$18,750.00
Teacher PD Membership	07/01/2026	06/30/2027	5	\$395.00	\$1,975.00
90 Min Virtual PD	07/01/2026	06/30/2027	1	\$1,500.00	\$1,500.00
School Setup Fee	07/01/2026	06/30/2027	2	\$0.00	\$0.00
Total					\$22,225.00

The price associated with the order form is only available if executed no later than 10/15/2026.

Description of Licenses:

Pro Teacher License HS (District): This license provides Pro access to 1 teacher, and all of their sections and students. This includes District level features.

Teacher PD Membership: Professional development membership for 1 teacher. This provides access to exclusive computer science PD sessions, as well as a library of recorded sessions.

90 Min Virtual PD: 90 minute virtual professional development workshop, led by the CodeHS PD team. Topic to be set between CodeHS and the customer.

School Setup Fee: Set up fee for a school.

Company Address:

CodeHS Inc.
747 N LaSalle Dr #500
Chicago, IL 60654
Phone: (415) 889-3376

Prepared by: Rachel McPhail



WASHINGTON COUNTY SCHOOLS

INSPIRE ★ STRIVE ★ THRIVE

Mr. Jerry S. Boyd
Superintendent

405 W. College St.
Jonesborough, TN 37659
Phone (423) 753-1100

TOTAL BID AMOUNT: \$ 89,741.29

By submitting this bid, the bidder agrees that the quoted products and services meet the stated specifications and will remain in compliance with Washington County Board of Education standards throughout the contract period.

Bidder Information:

Printed Name: Brandon Gibberson
Signature: *Brandon Gibberson*
Telephone #: 304-327-0149
Cell #: 304-320-5510
Fax #: 304-325-3848
Company Name: Douglas Equipment
Mailing Address: 301 North Street
City/State/ZIP: Bluefield, WV 24701
Date: 3-30-26
Email Address: gibberson@douglasequipment.com

Exceptions (If none, state "No conditions and/or exceptions.")

No conditions and/or exceptions

DOUGLAS EQUIPMENT



**Restaurant & Food Store
Equipment**





Quote

03/30/2026

Project:
26-6558/Washington County TN
Schools
Jonesborough, TN

From:

Item	Qty	Description	Sell	Sell Total
1	1 ea	FACTORY QUOTE Thermo-Kool Model No. WALK-IN Factory Quote #Q47249-25 Attached	\$29,691.90	\$29,691.90
	1 ea	WARRANTY Compressor warranty	\$198.45	\$198.45
	1 ea	INSTALLATION	\$18,359.25	\$18,359.25
			ITEM TOTAL:	\$48,249.60
2.1	8 ea	WIRE SHELVING Winco Model No. VEX-2448 Packed 2 ea Shelf, 48" x 24", includes (4) sleeve clips per shelf, wire, epoxy coated, green, NSF (Qty Break = 2 each)	\$50.50	\$404.00
				
			ITEM TOTAL:	\$404.00
2.2	11 ea	WIRE SHELVING Winco Model No. VEX-2436 Packed 2 ea Shelf, 36" x 24", includes (4) sleeve clips per shelf, wire, epoxy coated, green, NSF (Qty Break = 2 each)	\$41.62	\$457.82
				
			ITEM TOTAL:	\$457.82
2.3	16 ea	POST Winco Model No. VEX-72P Packed 4 ea Shelf Post, 72"H, epoxy coated, green, NSF (Qty Break = 4 each)	\$12.86	\$205.76
			ITEM TOTAL:	\$205.76
2.4	4 ea	POST	\$11.23	\$44.92

Item	Qty	Description	Sell	Sell Total
		Winco Model No. VEX-63P Packed 4 ea Shelf Post, 63"H, epoxy coated, green, NSF (Qty Break = 4 each)		
			ITEM TOTAL:	\$44.92
2.5	2 ea	CASTERS Winco Model No. VC-CT Packed 24 ea Caster, 5" dia., stem, for wire shelf (Qty Break = 4 each)	\$16.85	\$33.70
				
			ITEM TOTAL:	\$33.70
2.6	2 ea	CASTERS Winco Model No. VC-CTB Packed 24 ea Caster, 5" dia., stem, with brake, for wire shelf (Qty Break = 4 each)	\$18.97	\$37.94
				
			ITEM TOTAL:	\$37.94
3	1 ea	FACTORY QUOTE Thermo-Kool Model No. REFRIGERATION Factory Quote #Q47247-25 Attached	\$11,534.25	\$11,534.25
	1 ea	WARRANTY Compressor warranty	\$198.45	\$198.45
	1 ea	INSTALLATION	\$10,858.05	\$10,858.05
			ITEM TOTAL:	\$22,590.75
4	1 ea	COMBI OVEN, ELECTRIC RATIONAL Model No. ICP 6-HALF E 480V 3 PH (LM100BE) (CB1ERRA.0000213) iCombi Pro® 6-Half Size Combi Oven, electric, (6) 13" x 18" sheet pan or (6) 12" x 20" steam pan or (6) 1/1 GN pan capacity, intelligent cooking system with (4) assistants; iDensityControl, iCookingSuite, iProductionManager, & iCareSystem, (6) operating modes, (5) cooking methods, (3) manual operating modes, 85° to 572°F temperature range, quick clean, care control, eco mode, 6-point core temperature probe, retractable hand shower, Ethernet interface, Wi-Fi enabled, 480v/60Hz/3-ph, 14.2/13.0 amps, 10.8 kW, CE, IPX5, UL, cULus, NSF, ENERGY STAR®	\$10,216.87	\$10,216.87
				
	1 ea	NOTE: All discounts subject to approval by manufacturer		
	1 ea	2 years parts and labor, 5 years steam generator warranty		
	1 ea	CAP Chef Assistance Program, a RATIONAL certified Chef conducts 4 hours/location specialized application training with personnel, no charge		

Item	Qty	Description	Sell	Sell Total
1 ea		9999.2002 Pre-Installation Site Consultation, provides an installation consultation to ensure the site has proper space and connections for gas, electric, drain & water, one (1) Consultation is needed for every four (4) cooking systems, add 'in one (1) kitchen', includes 100 miles (200 miles round trip). (see attached installation flyer for details) THIS ITEM IS NON-DISCOUNTABLE, USA ONLY (NET)	\$525.00	\$525.00
1 ea		9999.2201 RCI RATIONAL Certified Installation, new certified installation for each individual electric table-top iCombi on a stand or counter, 100 miles (200 round-trip) included. (Do not use for Combi-Duo, See attached installation flyer for details) THIS ITEM IS NON-DISCOUNTABLE, USA ONLY (NET)	\$1,225.00	\$1,225.00
1 ea		8720.1553US Installation Kit, for electric iCombi/SCC/CMP 61 (440/60Hz/3 & 480/60Hz/3ph) THIS ITEM IS NON-DISCOUNTABLE, USA ONLY (NET)	\$404.27	\$404.27
1 ea		1900.1159US Water Filtration Single Cartridge System, for any single combi model, or XS & half-size Combi-Duos, or iVario includes: (1) single head with pressure gauge, R95-CLX filter & (1) filter installation kit	\$484.65	\$484.65
1 ea		9999.2271 RCI RATIONAL Certified Installation, additional installation cost for a RATIONAL Water Filter System is available when purchased with Certified Installation of RATIONAL unit THIS ITEM IS NON-DISCOUNTABLE, USA ONLY (NET)	\$175.00	\$175.00
1 ea		Note: The RATIONAL Water Filtration Systems helps provide consistent high-quality water to your RATIONAL cooking systems. The patented carbon block technology reduces the effects of sediment, chloramines, and chlorine while delivering the required flow rates.		
1 ea		56.01.535 Active Green Cleaner Tabs, for all iCombi Pro/Classic, 150 pieces/bucket (minimum order quantity- 2 ea, unless ordered with a unit) (NET)	\$117.58	\$117.58
1 ea		56.00.562 Care Tabs, bucket of 150 packets for all iCombi Pro/Classic models and SelfCooking Center® units from 10/2008, with CareControl - Serial SG, SH or SI series (minimum order quantity: 2pcs, unless ordered with a unit) (NET)	\$106.29	\$106.29
1 ea		60.31.086 Stand II Stationary Oven Stand, 26-3/8"H, (14) supporting rails, side panels and top closed, rear panel open, stainless steel construction, for iCombi 6- and 10-half size Classic/Pro	\$962.14	\$962.14
			ITEM TOTAL:	\$14,216.80
			Merchandise	\$86,241.29
			Freight	\$3,500.00
			Total	\$89,741.29



WASHINGTON COUNTY SCHOOLS

INSPIRE ★ STRIVE ★ THRIVE

Mr. Jerry S. Boyd
Superintendent

405 W. College St.
Jonesborough, TN 37659
Phone (423) 753-1100

TOTAL BID AMOUNT: \$ 85,773.81

By submitting this bid, the bidder agrees that the quoted products and services meet the stated specifications and will remain in compliance with Washington County Board of Education standards throughout the contract period.

Bidder Information:

Printed Name: Nino La Rosa

Signature: *Nino La Rosa*

Telephone #: 865-225-1545

Cell #: _____

Fax #: _____

Company Name: KaTom Restaurant Supply Inc.

Mailing Address: 305 KaTom Drive

City/State/ZIP: Kodak Tn 37764

Date: 3/30/2026

Email Address: nlarosa@katom.com



Exceptions (If none, state "No conditions and/or exceptions.")





Project:
Washington County Schools

From:
KaTom Restaurant Supply, Inc.
Nino La Rosa
305 KaTom Drive
Kodak, TN 37764

Job Reference Number: 107743

Item	Qty	Description	Sell	Sell Total
1	1 ea	FACTORY QUOTE Thermo-Kool Model No. WALK-IN Factory Quote #Q47249-25 Attached	\$29,766.32	\$29,766.32
	1 ea	WARRANTY Compressor warranty	\$189.00	\$189.00
			ITEM TOTAL:	\$29,955.32
2.1	8 ea	WIRE SHELVING Winco Model No. VEX-2448 Packed 2 ea Shelf, 48" x 24", includes (4) sleeve clips per shelf, wire, epoxy coated, green, NSF (Qty Break = 2 each)	\$57.91	\$463.28
				
			ITEM TOTAL:	\$463.28
2.2	11 ea	WIRE SHELVING Winco Model No. VEX-2436 Packed 2 ea Shelf, 36" x 24", includes (4) sleeve clips per shelf, wire, epoxy coated, green, NSF (Qty Break = 2 each)	\$47.72	\$524.92
				
			ITEM TOTAL:	\$524.92
2.3	16 ea	POST Winco Model No. VEX-72P Packed 4 ea Shelf Post, 72"H, epoxy coated, green, NSF (Qty Break = 4 each)	\$14.75	\$236.00
			ITEM TOTAL:	\$236.00
2.4	4 ea	POST	\$12.88	\$51.52

Item	Qty	Description	Sell	Sell Total
		Winco Model No. VEX-63P Packed 4 ea Shelf Post, 63"H, epoxy coated, green, NSF (Qty Break = 4 each)		
			ITEM TOTAL:	\$51.52
2.5	4 ea	CASTERS Winco Model No. VC-CT Packed 24 ea Caster, 5" dia., stem, for wire shelf (Qty Break = 4 each)	\$19.32	\$77.28
				
				NOTE - Verify Quantity Needed
			ITEM TOTAL:	\$77.28
3	1 ea	FACTORY QUOTE Thermo-Kool Model No. REFRIGERATION Factory Quote #Q47247-25 Attached	\$11,563.16	\$11,563.16
	1 ea	WARRANTY Compressor warranty	\$198.95	\$198.95
			ITEM TOTAL:	\$11,762.11
4	1 ea	COMBI OVEN, ELECTRIC RATIONAL Model No. ICP 6-HALF E 480V 3 PH (LM100BE) (CB1ERRA.0000213) iCombi Pro® 6-Half Size Combi Oven, electric, (6) 13" x 18" sheet pan or (6) 12" x 20" steam pan or (6) 1/1 GN pan capacity, intelligent cooking system with (4) assistants; iDensityControl, iCookingSuite, iProductionManager, & iCareSystem, (6) operating modes, (5) cooking methods, (3) manual operating modes, 85° to 572°F temperature range, quick clean, care control, eco mode, 6-point core temperature probe, retractable hand shower, Ethernet interface, Wi-Fi enabled, 480v/60Hz/3-ph, 14.2/13.0 amps, 10.8 kW, CE, IPX5, UL, cULus, NSF, ENERGY STAR®	\$10,765.93	\$10,765.93
				
	1 ea	NOTE: All discounts subject to approval by manufacturer		
	1 ea	2 years parts and labor, 5 years steam generator warranty		
	1 ea	CAP Chef Assistance Program, a RATIONAL certified Chef conducts 4 hours/location specialized application training with personnel, no charge		
	1 ea	9999.2002 Pre-Installation Site Consultation, provides an installation consultation to ensure the site has proper space and connections for gas, electric, drain & water, one (1) Consultation is needed for every four (4) cooking systems, add 'in one (1) kitchen', includes 100 miles (200 miles round trip). (see attached installation flyer for details) THIS ITEM IS NON-DISCOUNTABLE, USA ONLY (NET)	\$525.00	\$525.00

Item	Qty	Description	Sell	Sell Total
	1 ea	9999.2201 RCI RATIONAL Certified Installation, new certified installation for each individual electric table-top iCombi on a stand or counter, 100 miles (200 round-trip) included. (Do not use for Combi-Duo, See attached installation flyer for details) THIS ITEM IS NON-DISCOUNTABLE, USA ONLY (NET)	\$1,225.00	\$1,225.00
	1 ea	8720.1553US Installation Kit, for electric iCombi/SCC/CMP 61 (440/60Hz/3 & 480/60Hz/3ph) THIS ITEM IS NON-DISCOUNTABLE, USA ONLY (NET)	\$426.00	\$426.00
	1 ea	1900.1159US Water Filtration Single Cartridge System, for any single combi model, or XS & half-size Combi-Duos, or iVario includes: (1) single head with pressure gauge, R95-CLX filter & (1) filter installation kit	\$510.70	\$510.70
	1 ea	9999.2271 RCI RATIONAL Certified Installation, additional installation cost for a RATIONAL Water Filter System is available when purchased with Certified Installation of RATIONAL unit THIS ITEM IS NON-DISCOUNTABLE, USA ONLY (NET)	\$175.00	\$175.00
	1 ea	Note: The RATIONAL Water Filtration Systems helps provide consistent high-quality water to your RATIONAL cooking systems. The patented carbon block technology reduces the effects of sediment, chloramines, and chlorine while delivering the required flow rates.		
	1 ea	56.01.535 Active Green Cleaner Tabs, for all iCombi Pro/Classic, 150 pieces/bucket (minimum order quantity- 2 ea, unless ordered with a unit) (NET)	\$123.90	\$123.90
	1 ea	56.00.562 Care Tabs, bucket of 150 packets for all iCombi Pro/Classic models and SelfCooking Center® units from 10/2008, with CareControl - Serial SG, SH or SI series (minimum order quantity: 2pcs, unless ordered with a unit) (NET)	\$112.00	\$112.00
	1 ea	60.31.086 Stand II Stationary Oven Stand, 26-3/8"H, (14) supporting rails, side panels and top closed, rear panel open, stainless steel construction, for iCombi 6- and 10-half size Classic/Pro	\$1,013.85	\$1,013.85
			ITEM TOTAL:	\$14,877.38
5	1 ea	INSTALL FOR SOUTH CENTRAL Hobart Sales & Service Model No. INSTALL Remove old walk-in- freezer refrigeration equipment and discard. Receive new refrigeration system, install all equipment, start up, set temps, run drain, put in service. Misc. plumbing and electrical Crane fee if needed	\$10,341.00	\$10,341.00

Item	Qty	Description	Sell	Sell Total
		Receive Rational Combi oven transport to school location for others to install.		
			ITEM TOTAL:	\$10,341.00
6	1 ea	INSTALL FOR GRAY ELEMENTARY Hobart Sales & Service Model No. INSTALL Remove and discard of old walk-in freezer and refrigeration equipment Receive new walk-in freezer at school location uncrate, set up per drawing. Install all refrigeration equipment and drain, start up set all temps, put in service. Install all shelving Misc. plumbing and electrical Travel	\$17,485.00	\$17,485.00
			ITEM TOTAL:	\$17,485.00
			Total	\$85,773.81

Acceptance: _____ Date: _____

Printed Name: _____

Project Grand Total: \$85,773.81



WASHINGTON COUNTY SCHOOLS

INSPIRE ★ STRIVE ★ THRIVE

Mr. Jerry S. Boyd
Superintendent

405 W. College St.
Jonesborough, TN 37659
Phone (423) 753-1100

TOTAL BID AMOUNT: \$ 86,877.62

By submitting this bid, the bidder agrees that the quoted products and services meet the stated specifications and will remain in compliance with Washington County Board of Education standards throughout the contract period.

Bidder Information:

Printed Name: Nathan Duff
Signature: Nathan Duff
Telephone #: 865-693-3677
Cell #: 865-924-2274
Fax #: 865-693-3157
Company Name: Mobile Fixture
Mailing Address: 11220 Threadstone LN
City/State/ZIP: Knoxville, TN, 37932
Date: 3/27/2026
Email Address: nathan.duff@mobilefixture.com

Exceptions (If none, state "No conditions and/or exceptions.")

No conditions and/or exceptions.



WASHINGTON COUNTY SCHOOLS

INSPIRE ★ STRIVE ★ THRIVE

Mr. Jerry S. Boyd
Superintendent

405 W. College St.
Jonesborough, TN 37659
Phone (423) 753-1100

TOTAL BID AMOUNT: \$ 80,943.88

By submitting this bid, the bidder agrees that the quoted products and services meet the stated specifications and will remain in compliance with Washington County Board of Education standards throughout the contract period.

Bidder Information:

Printed Name: Heidi Keller Lawson
Signature: *Heidi Keller Lawson*
Telephone #: 865.545.5222
Cell #: 865.640.8877
Fax #: _____
Company Name: Trimark USA, LLC
Mailing Address: 3011 Industrial Parkway East
City/State/ZIP: Knoxville, TN 37921
Date: 3/24/26
Email Address: Heidemarie.keller@trimarkusa.com

Exceptions (If none, state "No conditions and/or exceptions.")



Foodservice Equipment, Supplies and Design

Strategic Equipment, LLC
dba TriMark Strategic
dba TriMark Foodcraft
dba ISI Commercial Refrigeration

Quote

03/27/2026



Project:
**Washington Co- Freezers and
Oven**
Jonesborough, TN



From:
Trimark USA, LLC
Heidi Keller-Lawson
3011 Industrial Parkway East
Knoxville, TN 37921
(865)545-5222 (contact)
(865)522-4448 (Fax)

Prices may not reflect applicable tariffs, duties, import fees, taxes, or other governmental charges. TriMark reserves the right to correct or adjust quoted prices at any time due to tariffs, market fluctuations, supply chain disruptions, third-party supplier cost changes, general contractor delays, or any other factors outside of TriMark's control. TriMark will use commercially reasonable efforts to hold pricing for seven calendar days from the date of the quote; however, all pricing remains subject to correction or adjustment as set forth above, including during the seven-day hold period.

For all custom fabricated equipment, exhaust hoods, walk-in coolers/freezers, and all items requiring owner selections of colors or laminate finishes, these prices are current estimates. We will re-quote those items based on the manufacturers' prices in effect at the time when field measurements can be taken and/or color/laminate selections are made by the owner. This policy also applies to all items of standard manufacture that cannot be shipped immediately upon fabrication to an owner's or general contractor's facility.

Item	Qty	Description	Sell	Sell Total
GRAY ELEMENTARY				
1	1 ea	FACTORY QUOTE Model No. WALK-IN Factory Quote #Q47249-25	\$23,616.83	\$23,616.83
	1 ea	WARRANTY Compressor warranty		
			ITEM TOTAL:	\$23,616.83

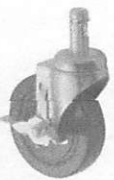
Item	Qty	Description	Sell	Sell Total
1.1	1	Model No. 8990 Installation Remove and discard of old walk-in freezer and refrigeration equipment Receive new walk-in freezer at school location uncrate, set up per drawing. Install all refrigeration equipment and drain, start up set all temps, put in service. Install all shelving	\$20,107.75	\$20,107.75
			ITEM TOTAL:	\$20,107.75
2.1	8 ea	WIRE SHELVING Model No. VEX-2448 Shelf, 48" x 24", includes (4) sleeve clips per shelf, wire, epoxy coated, green, NSF (Qty Break = 2 each)	\$54.73	\$437.84
				
			ITEM TOTAL:	\$437.84
2.2	11 ea	WIRE SHELVING Model No. VEX-2436 Shelf, 36" x 24", includes (4) sleeve clips per shelf, wire, epoxy coated, green, NSF (Qty Break = 2 each)	\$45.10	\$496.10
			ITEM TOTAL:	\$496.10
2.3	16 ea	POST Model No. VEX-72P (10127139) Shelf Post, 72"H, epoxy coated, green, NSF (Qty Break = 4 each)	\$13.94	\$223.04
			ITEM TOTAL:	\$223.04
2.4	4 ea	POST Model No. VEX-63P Shelf Post, 63"H, epoxy coated, green, NSF (Qty Break = 4 each)	\$12.17	\$48.68
				
			ITEM TOTAL:	\$48.68
2.5	2 ea	CASTERS Model No. VC-CT Caster, 5" dia., stem, for wire shelf (Qty Break = 4 each)	\$18.26	\$36.52
				
			ITEM TOTAL:	\$36.52

Item	Qty	Description	Sell	Sell Total
2.6	2 ea	CASTERS Model No. VC-CTB Caster, 5" dia., stem, with brake, for wire shelf (Qty Break = 4 each)	\$20.56	\$41.12
				
			ITEM TOTAL:	\$41.12
2.7	1 ea	FREIGHT Model No. 8880 Freight	\$406.80	\$406.80
			ITEM TOTAL:	\$406.80
SOUTH CENTRAL ELEMENTARY				
3	1 ea	FACTORY QUOTE Model No. REFRIGERATION Factory Quote #Q47247-25	\$9,238.57	\$9,238.57
	1 ea	WARRANTY Compressor warranty		
			ITEM TOTAL:	\$9,238.57
3.1	1	Model No. 8990 Installation Remove and discard of old walk-in freezer and refrigeration equipment Receive new walk-in freezer at school location uncrate, set up per drawing. Install all refrigeration equipment and drain, start up set all temps, put in service.	\$10,540.90	\$10,540.90
	1	CRANE FEE Crane fee if needed	\$920.00	<Optional>
			ITEM TOTAL:	\$10,540.90
4	1 ea	COMBI OVEN, ELECTRIC Model No. ICP 6-HALF E 480V 3 PH (LM100BE) (CB1ERRA.0000213) iCombi Pro® 6-Half Size Combi Oven, electric, (6) 13" x 18" sheet pan or (6) 12" x 20" steam pan or (6) 1/1 GN pan capacity, intelligent cooking system with (4) assistants; iDensityControl, iCookingSuite, iProductionManager, & iCareSystem, (6) operating modes, (5) cooking methods, (3) manual operating modes, 85° to 572°F temperature range, quick clean, care control, eco mode, 6-point core temperature probe, retractable hand shower, Ethernet interface, Wi-Fi enabled, 480v/60Hz/3-ph, 14.2/13.0 amps, 10.8 kW, CE, IPX5, UL, cULus, NSF, ENERGY STAR®	\$15,318.48	\$15,318.48
	1 ea	NOTE: All discounts subject to approval by manufacturer		
	1 ea	2 years parts and labor, 5 years steam generator warranty		
	1 ea	CAP (10075273) Chef Assistance Program, a RATIONAL certified Chef conducts 4 hours/location specialized application training with personnel, no charge		
	1 ea	9999.2002 (10088824) Pre-Installation Site Consultation, provides an installation consultation to ensure the site has proper space		
				

Item	Qty	Description	Sell	Sell Total
		and connections for gas, electric, drain & water, one (1) Consultation is needed for every four (4) cooking systems, add 'in one (1) kitchen', includes 100 miles (200 miles round trip). (see attached installation flyer for details) THIS ITEM IS NON- DISCOUNTABLE, USA ONLY (NET)		
1 ea		9999.2201 RCI RATIONAL Certified Installation, new certified installation for each individual electric table-top iCombi on a stand or counter, 100 miles (200 round-trip) included. (Do not use for Combi-Duo, See attached installation flyer for details) THIS ITEM IS NON-DISCOUNTABLE, USA ONLY (NET)		
1 ea		8720.1553US (10098403) Installation Kit, for electric iCombi/SCC/CMP 61 (440/60Hz/3 & 480/60Hz/3ph) THIS ITEM IS NON-DISCOUNTABLE, USA ONLY (NET)		
1 ea		1900.1159US (10098477) Water Filtration Single Cartridge System, for any single combi model, or XS & half-size Combi-Duos, or iVario includes: (1) single head with pressure gauge, R95-CLX filter & (1) filter installation kit		
1 ea		9999.2271 (10056122) RCI RATIONAL Certified Installation, additional installation cost for a RATIONAL Water Filter System is available when purchased with Certified Installation of RATIONAL unit THIS ITEM IS NON-DISCOUNTABLE, USA ONLY (NET)		
1 ea		Note: The RATIONAL Water Filtration Systems helps provide consistent high-quality water to your RATIONAL cooking systems. The patented carbon block technology reduces the effects of sediment, chloramines, and chlorine while delivering the required flow rates.		
1 ea		56.01.535 (10033133) Active Green Cleaner Tabs, for all iCombi Pro/Classic, 150 pieces/bucket (minimum order quantity- 2 ea, unless ordered with a unit) (NET)		
1 ea		56.00.562 (10064514) Care Tabs, bucket of 150 packets for all iCombi Pro/Classic models and SelfCooking Center® units from 10/2008, with CareControl - Serial SG, SH or SI series (minimum order quantity: 2pcs, unless ordered with a unit) (NET)		
1 ea		60.31.086 (10041075) Stand II Stationary Oven Stand, 26-3/8"H, (14) supporting rails, side panels and top closed, rear panel open, stainless steel construction, for iCombi 6- and 10-half size Classic/Pro		
			ITEM TOTAL:	\$15,318.48
4.1	1	Model No. 8990 Receive Rational Combi oven transport to school location for others to install.	\$431.25	\$431.25
			ITEM TOTAL:	\$431.25
			Total	\$80,943.88

This Quote shall be subject to TriMark's Terms of Sale <https://www.trimarkusa.com/SiteMedia/SiteResources/Terms/TriMark-Terms-and-Conditions-of-Sale.pdf>, which are incorporated herein by reference and shall govern. The parties specifically agree that no signature shall be required in order for this Quote or its applicable terms and conditions to be deemed legally binding and enforceable on Customer where the intent to be so bound can be inferred (including by acceptance or retention of products or services), notwithstanding contrary requirements under any law.

Any tax or similar fees shown in this Quote are an estimate only.

Florida Refrigeration License # CAC1821900

Austin	Beaumont	Houston	Lewisville
TACLB52729R	TACLA35912C	TACLA108388C	TACLB16860C

Regulated by the Texas Department of Licensing and Regulation, P.O. BOX 12157, Austin, Texas, 1-800-803-9202. www.tdlr.texas.gov

I understand, agree to and accept the above terms and conditions.

Jerry S. Boyd
Superintendent



WASHINGTON
COUNTY SCHOOLS
INSPIRE ★ STRIVE ★ THRIVE

BOARD OF EDUCATION
Eric Barnes
Annette Buchanan
Keith Ervin
Chad Fleenor
David Hammond
Gregg Huddleston
Mike Masters
Whitney Riddle
Vince Walters

RESOLUTION OPPOSING EXPANSION OF EDUCATION FREEDOM SCHOLARSHIP PROGRAM

WHEREAS, the Constitution of the State of Tennessee, in Article XI, Section 12, provides that the General Assembly “shall provide for the maintenance, support, and eligibility standards of a system of free public schools”; and

WHEREAS, the fulfillment of this constitutional obligation depends upon stable and adequate public investment in local public school systems that serve all students, regardless of background, ability, or need; and

WHEREAS, local boards of education are charged with governing public schools in a manner that ensures students are prepared for postsecondary education, military service, or entry into the workforce, while remaining accountable to the communities they serve; and

WHEREAS, in 2025 the State of Tennessee enacted the Education Freedom Scholarship program, creating a statewide private school voucher program funded with public dollars; and

WHEREAS, the Education Freedom Scholarship program remains in the early stages of implementation, and there is insufficient data to demonstrate that the program has produced positive student outcomes, improved educational quality, or provided a clear benefit to Tennessee students or taxpayers; and

WHEREAS, legislation has been proposed to expand the Education Freedom Scholarship program from 25,000 to 40,000 scholarships beginning in the 2026–27 school year; and

WHEREAS, expanding a program of this scale without demonstrated success increases fiscal risk to the state and further diverts limited education funding away from public schools that are constitutionally required to serve all students;

NOW, THEREFORE, BE IT RESOLVED, that the Washington County Board of Education hereby opposes the proposed expansion of the Education Freedom Scholarship program and respectfully urges the Tennessee General Assembly to reject legislation that would increase the number of available Education Freedom Scholarships.

THIS RESOLUTION is adopted as of this 2nd day of APRIL 2026.

WASHINGTON COUNTY BOARD OF EDUCATION

Annette Buchanan, Chair

David Hammond, Vice Chair

Eric Barnes

Keith Ervin

Chad Fleenor

Gregg Huddleston

Mike Masters

Whitney Riddle

Vince Walters

1ST AND 2ND READING

Washington County Board of Education

Monitoring: Review: Annually	Descriptor Term: Appeals to and Appearances before the Board	Descriptor Code: 1.609	Issued Date: 06/29/23
		Rescinds: 1.609	Issued: 09/02/21

1 **APPEALS TO THE BOARD**

2 Any matter relating to the operation of the school system may be appeal to the Board. However, the
3 Board desires that all matters be settled at the lowest level of responsibility and will not hear
4 complaints or concerns which have not advanced through the proper administrative procedure from the
5 point of origin.

6 If all administrative channels have been pursued and there is still a desire to appeal to the Board, the
7 matter shall be referred in writing and the Board shall determine whether to hear the appeal.

8 **APPEARING BEFORE THE BOARD**

9 Individuals desiring to appear before the Board may request placement on the agenda by contacting the
10 office of the director of schools forty-eight (48) hours before the meeting. They will be recognized at
11 the beginning of the meeting and given time to speak when their topic of interest is addressed on the
12 agenda. Sufficient background material will be provided by the speaker. The chairman may recognize
13 individuals not on the agenda for remarks to the Board if he/she determines that such is in the public
14 interest. A majority vote of members present can overrule the decision of the chairman.¹

15 *Public Comment Period²*

16 There shall be a public comment period for each meeting with actionable items on the agenda, with the
17 exception of teacher disciplinary hearings. Comments shall be limited to topics listed on the agenda
18 **and matters that are germane to the school board's jurisdiction**. The total public comment period shall
19 be for no more than three (3) minutes. If an individual wishes to address the Board, he/she shall sign
20 up on the form provided before the beginning of the board meeting to request time to speak. Each
21 speaker shall be given no more than (3) minutes. Delegations must select only one individual to speak
22 on their behalf unless otherwise determined by the Board.

23 *Adding an Item to the Agenda*

24 Individuals desiring to appear before the Board shall submit a written request with descriptive
25 materials to the office of the Director of Schools forty-eight (48) hours before the meeting. If the
26 request is approved by the executive committee, the item will be placed on the agenda. Individuals
27 placed on the agenda will be recognized at the beginning of the meeting and given three (3) minutes to
28 speak when their time is addressed on the agenda. All requests submitted will be included in the board
29 packet.

- 1 Individuals speaking to the Board shall address remarks to the chairman and may direct questions to
2 individual board members or staff members only upon approval of the chairman. Each person speaking
3 shall state his/her name, address, and subject of presentation. Remarks will be limited to three (3)
4 minutes unless time is extended by a majority vote of the Board. The chairman shall have the authority
5 to terminate the remarks of any individual who does not adhere to the above rules or chooses to be
6 abusive to an individual board member or the Board as a whole. Members of the Board and the
7 Director of Schools may have the privilege of asking questions of any person who addresses the Board.
- 8 Issues requiring response of the Board shall be directed by the chairman to the appropriate committee
9 or the director of schools and staff for their advisement. Further recommendations will be presented to
10 the entire board.
- 11 Individuals desiring additional information about any item on the agenda shall direct such inquiries to
12 the office of the director of schools.

Legal References

1. TCA 39-17-306
2. TCA 8-44-112

Cross References

School Board Meetings 1.400
Public Hearings 1.401
Agendas 1.403
Discrimination/Harassment of Employees 5.500
Complaints and Grievances 5.501
Student Discrimination, Harassment, Bullying, Cyber-
bullying, and Intimidation 6.304
Student Concerns 6.305

Washington County Department of Education
School Educational **OVERNIGHT** Trip Authorization*

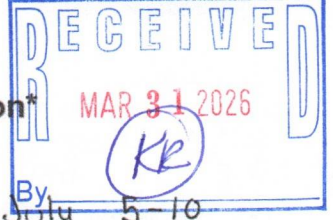

Date of Request 3/30/2026 School DCHS Trip Date By July 5-10

Estimated time of departure 7:45 a.m. and return 7:45 a.m. total time away 5 Days

Destination (include location) FCCLA NLC Washington D.C.

Teacher Courley Class FCCLA Grade 9-12

Chaperones TBD Number of Students Involved 6

Estimated Total Miles (both ways) of Trip _____

Bus Driver/Number School or Rental Vans or Fly Bus Driver/ Number _____

Will Chaperones have a list (roll) that they are responsible for? Yes

As you plan the trip, will all children be given instructions as to what they should do if they become separated (lost) from the group? Yes

Will you have on file parental release forms signed by parents or legal guardians? Yes

Explain the educational value of the trip: Students will attend leadership conference and compete at Nationals.

Total Cost Estimate \$20,000

Plans for meeting the costs Student Paid / FCCLA Funds

Transportation cost for educational trips shall be calculated in the following manner:
\$16.00 per hour for driver (2 hour minimum)
\$ 3.15 per hour to cover fixed charges (SS, retirement, etc.)
\$19.15 total to be remitted to the central office per hour

Reimbursement for the bus and fuel shall be made at the rate of \$.75 per mile.
*Refer to Board Policy 4.302

[Signature]
Principal's Signature

3.31.26
Date

APPROVED
BY WC SUPERINTENDENT
[Signature]
Superintendent's Signature

3/31/2026
Date

Date Approved by the Board of Education _____

Washington County Department of Education
School Educational **OVERNIGHT** Trip Authorization



Date of Request 3/30/26 School DCHS Trip Date April 20th - 23rd

Estimated time of departure 4/20 9 A.M. and return 4/23 4 P.M. total time away _____

Destination (include location) "The Works 2024" construction contest Franklin, TN.

Teacher Good Class Residential + Commercial Construction Grade 10-12

Chaperones TBD Number of Students Involved 10
Estimated Total Miles (both ways) of Trip 500

Bus Driver/Number Vans Bus Driver/ Number Vans

Will Chaperones have a list (roll) that they are responsible for? Yes

As you plan the trip, will all children be given instructions as to what they should do if they become separated (lost) from the group? yes

Will you have on file parental release forms signed by parents or legal guardians? Yes

Explain the educational value of the trip: Students will be in competition with other high schools in their field of study

Total Cost Estimate \$6,000

Plans for meeting the costs Sponsorships from local businesses.

Transportation cost for educational trips shall be calculated in the following manner:
\$16.00 per hour for driver (2 hour minimum)
\$ 3.15 per hour to cover fixed charges (SS, retirement, etc.)
\$19.15 total to be remitted to the central office per hour

Reimbursement for the bus and fuel shall be made at the rate of \$0.75 per mile.
*Refer to Board Policy 4.302

Ashley Aquil
Principal's Signature
APPROVED BY WC SUPERINTENDENT
[Signature]
Superintendent's Signature

3.31.24
Date
3/31/2024
Date

Date Approved by the Board of Education _____