

**WASHINGTON COUNTY
BOARD OF EDUCATION**

April 3, 2025

5:30 PM

Central Office

- I. Call to Order**
- II. Recognition of South Central Elementary Students Chase Perry and John Allen Martin**
- III. Presentation from BrightRidge**
- IV. Recognition of Kelly Wagner, selected as Tennessee's Coordinated School Health Supervisor of the Year**
- V. Recognition of Personnel Receiving Tenure**
- VI. Consideration of Meeting Agenda**
- VII. Public Comment**
- VIII. Approval of Meeting Minutes**
 - A. March 4, 2025 Regular meeting**
 - B. March 18, 2025 Workshop**
- IX. Announcements**
 - A.**
 - Health, Education & Welfare Committee**
April 2, 2025; 1:00 p.m.
 - B.**
 - Good Friday**
April 18, 2025
 - Easter Monday**
April 21, 2025
 - Schools and District Offices Closed**
 - C.**
 - Board Workshop**
April 22, 2025; 5:00 p.m.
 - D.**
 - Top Ten Banquet**
Millennium Center
April 29, 2025; 7:00 p.m.
- X. Superintendent's Report**
 - A. Mackenzie Gaby, David Crockett High School**
 - B. Enrollment Report**

- C. **Field Trips Report**
- D. **Monthly Financials**
- E. **Grants Report**
- F. **Maintenance Report**
- G. **Personnel Report**
- XI. **Consideration of Consent Agenda**
 - A. **Overnight Trip Requests**
 1. **Daniel Boone High School**
Nashville, TN
Band
April 10th-13th, 2025
Duration: 4 days
 2. **David Crockett High School**
Knoxville, TN
Girls Volleyball
August 22nd-23rd, 2025
Duration: 2 days
 3. **David Crockett High School**
Matthews, NC
Track & Field
April 26th-27th, 2025
Duration: 1 Day
 4. **David Crockett High School**
Greeneville, OH
Ag-Sheep Show & Sale
May 7th-9th, 2025
Duration: 2 days
 5. **David Crockett High School**
Cookeville, TN
Ag-State Nursery & Landscape Contest
April 21st-22nd, 2025
Duration: 1 day
 - B. **Purchase Orders**
 1. **Purchase Order 4879; Tailored Closet, Bluff City, TN; Replacement of floor in CTE Classroom at Grandview Elementary; Funded by ISM Grant; \$10,975.00; Line Item 141E 76100 707-000-00000-002**
 2. **Purchase Order 4880; Preston Woodworking, Johnson City, TN; Plastic Laminate Cabinets for CTE Classroom at Grandview Elementary; Funded by ISM Grant 141E 76100-707-000-00000-002; \$15,917.00**
 3. **Purchase Order 4836; Ferguson Enterprises, Johnson City, TN; Emergency Water Heater Purchase for David Crockett High 141E 72620-336-000-00016; \$12, 618.24**
 4. **Purchase Order 35832; TNTP, Inc., New York, NY; ELA Curriculum Implementation Support; System-wide; Year 4 (3rd installment);**

SY24-25; Contract #CC21090266; \$18,200.00; Line Item 142E 72210
399 951

- C. Approval of the CodeHS Proposal for implementation of a Computer Science Program (required course for middle school and high school); SY 2025-2026; \$62,880.00; Line Item 141E 71100-449
 - D. Approval of the Print Shop Production Machine Replacement at David Crockett High; RJ Young RICOH Pro; \$2,045.04 mo. plus applicable copies; 141 General Fund; This change consolidates all printers to the main system-wide bill through RJ Young. Expense Line 141E 72320-399
 - E. Approval of Frontline Annual Renewal; Substitute Management System & HR Hiring System; Effective 7/1/2025 - 6/30/2026; \$62,352.08; Line Item 141E 71100-399
 - F. Approval to award bid to Finchum Sports Floors, LLC (Sevierville, TN) for the refinishing of the gym floors at Lamar Elementary and David Crockett High; \$48,996.00; Line Item 141E 72620-335-000-00011 (Lamar Elementary); Line Item 141E 72620-335-000-00016 (David Crockett High)
- XII. Discussions/Presentations
- A. Updates: Lewis Group Architects
 - B. Resolution to Meet Requirement for Teacher Bonuses Under Education Freedom Scholarship Act
 - C. Approval of FY25 Dietary Budget Amendment #1
 - D. Gordon Food Service, Chicago, IL; Food Purchase; School Nutrition Department; Requisition #1430250318; \$300,000.00; Line Item 143E 73100 422
 - E. FY26 General Purpose Budget
 - F. Matching Grants Approval (Board of Education funds required)
 - 1. *School-Based Mental Health Services Grant* (matching fund \$50,000 per year for 5yrs); Salaries for 2 Interventionists, focusing behavioral support to tier 2 students.
 - 2. *Electric Bus Grant* (matching fund \$94,000 to \$220,000); Electric Bus with charging station to be housed at Jonesborough Elementary.
 - 3. *Community Oriented Policing Services (COPS)* (matching fund \$166,667 over 3-years); School Safety, fencing, bullet resistance film to put over the glass, addition support/equipment for WCSO SRO's as needed.
 - G. Approval of the Science Textbook Adoption Recommendation and Purchase of the Textbooks as presented.
 - 1. Purchase Order 4894; Tennessee Book Company, LaVergne, TN; Science Textbooks; \$859,280.07; Line Item 141E 71100-449
 - H. Purchase Orders
 - 1. Purchase Order 4900; Tailored Closet, Bluff City, TN; Epoxy floor installation and tile removal in CTE classroom at Gray Elementary; Funded by ISM Grant; \$12,600.00; Line Item 141E 76100 707 000 00000 002

2. **Purchase Order 4899; Paxton/Patterson LLC, Alsip, IL; Sole Provider; Learning Systems for CTE; Gray Elementary; \$22,875.00; Line Item 141E 71300 730 000 00000 002**
3. **Purchase Order 4898; Snap-On Industrial, Crystal Lake, IL; Sole Source; Tool ID and Safety Certification Kit, Consumables Kit; Sulphur Springs Elementary; Funded by ISM Grant; \$13,258.40; Line Item 141E 71300 730 000 00000 002.**

I. Policy 3.208: Community Use of Facilities

XIII. Adjournment

WASHINGTON COUNTY BOARD OF EDUCATION

March 4, 2025; 5:30 PM; Central Office

Those present were Chairman Annette Buchanan, Vice-Chair David Hammond, Eric Barnes, Whitney Riddle, Mike Masters, Keith Ervin, Gregg Huddleston and Superintendent Jerry Boyd. Board member Vince Walters was absent.

I. Call to Order

Mr. Fleenor led a prayer followed by the pledge to the flag lead by Kendall Hodge.

II. Ridgeview Elementary Students

III. Introduction of 2025 SCOPE Students and 2025-2026 Student Board Members

Daniel Boone High School

Lilly Fleenor

Jodontis Robinson

David Crockett High School

Hannah Campbell

Tyler Ball

IV. Consideration of Meeting Agenda

Chad Fleenor moved for approval of the meeting agenda. David Hammond seconded the motion.

Annette Buchanan moved to amend the motion to pull the Lamar personnel and take action separately. David Hammond seconded the motion which carried on roll call vote:

- Vince Walters: *absent*
- Eric Barnes: *yes*
- Keith Ervin: *yes*
- Chad Fleenor: *no*
- David Hammond: *yes*
- Gregg Huddleston: *yes*
- Mike Masters: *yes*
- Whitney Riddle: *yes*
- Annette Buchanan: *yes*

The motion as amended carried on roll call vote:

- Vince Walters: *absent*
- Eric Barnes: *yes*
- Keith Ervin: *yes*
- Chad Fleenor: *yes*
- David Hammond: *yes*
- Gregg Huddleston: *yes*
- Mike Masters: *yes*

- Whitney Riddle: *yes*
- Annette Buchanan: *yes*

V. Public Comment

There was no public comment.

VI. Approval of Meeting Minutes

A. February 6, 2025 (Regular Meeting)

B. February 25, 2025 (Workshop)

C. February 27, 2025 (Joint Worksession with Washington County Commission)

Chad Fleenor moved for approval of the meeting minutes as presented. Mike Masters seconded the motion which carried on roll call vote:

- Vince Walters: *absent*
- Eric Barnes: *yes*
- Keith Ervin: *yes*
- Chad Fleenor: *yes*
- David Hammond: *yes*
- Gregg Huddlestone: *yes*
- Mike Masters: *yes*
- Whitney Riddle: *yes*
- Annette Buchanan: *yes*

VII. Announcements

A. AASA National Conference

March 5-8, 2025; New Orleans, LA

B. Health, Education & Welfare Committee

March 6, 2025; 1:00 p.m.

C. TSBA SCOPE Conference

March 11, 2025

Belmont University; Nashville, TN

D. Monthly Workshop

March 18, 2025; 5:00 p.m.

E. Spring Break

March 24-28, 2025

F. County Commission

March 24, 2025; 6:00 p.m.

G. Special Olympics Track & Field

ETSU Mini-Dome

March 31, 2025

9:00 a.m. - 2:00 p.m.

H. Board Meeting

April 4, 2025; 5:30 p.m.

VIII. Superintendent's Report

A. Kendall Hodge, Student Board Member, David Crockett High School

B. Field Trip Report

C. Grants Report

D. Monthly Financials

E. FY25 2nd Quarter Financial Summary Reports

F. Maintenance Report

G. Personnel Report

H. Other

IX. Consideration of Consent Agenda

A. Purchase Orders

1. Purchase Order 4866; Benchmark Education; New Rochelle, NY; Literacy Software; Tutoring Support; Grades 3-5; District-wide; Funded by Niswonger Grant; \$11,231.00; Line Item 141E 71100 499 000 00000 200

2. Purchase Order 4699; Preston Woodworking; Johnson City, TN; Plastic Laminate Casework for CTE classroom at Gray Elementary; Funded by CTE ISM Grant; \$11,778.00; Line Item 141E 76100 707 000 0000 002

3. Purchase Order 4729; Preston Woodworking; Johnson City, TN; Plastic Laminate Casework for CTE Classroom at Ridgeview Elementary; Funded by CTE ISM Grant; \$11,996.00; Line Item 141E 76100 707 000 00000 002

4. Purchase Order 35785; University of Tennessee Center for Learning, Education and Employment; Knoxville, TN; Professional Development; Funded by SPED Grant; Not to exceed \$40,000.00; Line Item 142E 72220 425 898

B. Approval to release of bids for school system property/liability insurance

C. Approval to release bids for Gym Floor refinishing (David Crockett High and Lamar Elementary)

D. Approval to release bids for Cooler and Freezer Updates at David Crockett High School; Line Item 143E 73100-710

E. Overnight Trip Requests

**1. Daniel Boone High School
State Skills USA Competition**

**Chattanooga, TN
April 13-16th, 2025**

**2. David Crockett High School
Volleyball Team
University of Kentucky
July 12-14th, 2025
Duration 3 Days**

**3. David Crockett High School
Volleyball Team
Spartanburg, South Carolina
September 26th-27th, 2025
Duration 1 Day**

**4. David Crockett High School
HOSA Competiton Team
Chattanooga, TN
March 30th-April 2nd, 2025
Duration 3 Days**

Chad Fleenor moved for approval of the consent agenda. Gregg Huddlestone seconded the motion which carried on roll call vote:

- Vince Walters: *absent*
- Eric Barnes: *yes*
- Keith Ervin: *yes*
- Chad Fleenor: *yes*
- David Hammond: *yes*
- Gregg Huddlestone: *yes*
- Mike Masters: *yes*
- Whitney Riddle: *yes*
- Annette Buchanan: *yes*

X. Discussions/Presentations

A. Project Updates

B. Release bids for the HVAC design/engineering services at Daniel Boone High School; No funding source identified

Chad Fleenor moved for approval to release bids for the HVAC design/engineering services at Daniel Boone High School, using Education Capital Funds. Eric Barnes seconded the motion which carried on roll call vote:

- Vince Walters: *absent*
- Eric Barnes: *yes*
- Keith Ervin: *yes*
- Chad Fleenor: *yes*
- David Hammond: *yes*

- Gregg Huddlestone: *yes*
- Mike Masters: *yes*
- Whitney Riddle: *yes*
- Annette Buchanan: *yes*

C. Fire Alarm Upgrade Needs

D. Recommendations for Tenure Status

Chad Fleenor moved for approval to grant tenure status to the personnel withholding Lamar Elementary. Whitney Riddle seconded the motion which carried on roll call vote:

- Vince Walters: *absent*
- Eric Barnes: *yes*
- Keith Ervin: *yes*
- Chad Fleenor: *yes*
- David Hammond: *yes*
- Gregg Huddlestone: *yes*
- Mike Masters: *yes*
- Whitney Riddle: *yes*
- Annette Buchanan: *yes*

Keith Ervin recommendation for approval of the Lamar Elementary personnel as tenure. Whitney Riddle seconded the motion which carried on roll call vote:

- Vince Walters: *absent*
- Eric Barnes: *yes*
- Keith Ervin: *yes*
- Chad Fleenor: *yes*
- David Hammond: *yes*
- Gregg Huddlestone: *yes*
- Mike Masters: *yes*
- Whitney Riddle: *yes*
- Annette Buchanan: *abstain (with conflict)*

E. Job Description for Executive Principal

Mike Masters moved for approval of the job description for Executive Principal; on a two-year trial basis. Chad Fleenor seconded the motion which carried on roll call vote:

- Vince Walters: *absent*
- Eric Barnes: *yes*
- Keith Ervin: *no*
- Chad Fleenor: *yes*
- David Hammond: *yes*
- Gregg Huddlestone: *yes*

- Mike Masters: *yes*
- Whitney Riddle: *yes*
- Annette Buchanan: *yes*

F. Overnight Trip Request

**1. Daniel Boone High School
Tennessee FFA State Convention
Gatlinburg, TN
March 23rd-26th, 2025
Duration 4 Days**

**2. TSBA SCOPE Conference
Belmont University
March 10-11, 2025**

**3. Daniel Boone High School
TSA State Leadership Conference
Chattanooga, TN
April 2nd-5th, 2025
Duration 3 days**

**4. David Crockett High School
Skills USA CTSO
Chattanooga, TN
April 13th-16th, 2025
Duration 3 days**

Chad Fleenor moved for approval of the overnight trip requests, as presented. Mike Masters seconded the motion which carried on roll call vote:

- Vince Walters: *absent*
- Eric Barnes: *yes*
- Keith Ervin: *yes*
- Chad Fleenor: *yes*
- David Hammond: *yes*
- Gregg Huddleston: *yes*
- Mike Masters: *yes*
- Whitney Riddle: *yes*
- Annette Buchanan: *yes*

XI. Adjournment

WASHINGTON COUNTY BOARD OF EDUCATION

March 18, 2025; 5:00 PM; Central Office

Those present were Chairman Annette Buchanan, Eric Barnes, Whitney Riddle, Mike Masters, Keith Ervin, Vince Walters, Chad Fleenor, and Superintendent Jerry Boyd. Board members David Hammond and Gregg Huddleston were absent.

I. Call to Order

II. Daniel Boone High and David Crockett High Educentric Programs

School representatives from both high schools were present and shared about participating in the Educentric Program.

III. First Tennessee Development District

Andria Smith and Lexie Vance were present, Alicia Summers and Lottie Ryans joined the meeting remotely.

The group presented a proposal of converting the old Jonesborough Elementary School into a community childcare program. School system personnel would also be included in receiving the childcare.

IV. Academics

A. 2025 Summer Academy

B. AMP 2029

C. Science Textbook Adoption Recommendation and Purchase

Staff will be meeting with the publisher on April 2nd and the request for approval will be on the April 3rd Board meeting agenda.

D. CodeHS Proposal for implementation of a Computer Science Program (required course for middle school and high school); SY 2025-2026; \$62,880.00; Line Item 141E 71100-449

V. Business/Finance

A. Purchase Orders

1. Purchase Order 4879; Tailored Closet, Bluff City, TN; Replacement of floor in CTE Classroom at Grandview Elementary; Funded by ISM Grant; \$10,975.00; Line Item 141E 76100 707-000-00000-002

2. Purchase Order 4880; Preston Woodworking, Johnson City, TN; Plastic Laminate Cabinets for CTE Classroom at Grandview Elementary; Funded by ISM Grant 141E 76100-707-000-00000-002; \$15,917.00

3. Purchase Order 4836; Ferguson Enterprises, Johnson City, TN; Emergency Water Heater Purchase for David Crockett High 141E 72620-336-000-00016; \$12, 618.24

B. Print Shop Production Machine Replacement at David Crockett High; RJ Young RICOH Pro; \$2,045.04 mo. plus applicable copies; 141 General Fund; This change consolidates all printers to the main system-wide bill through RJ Young. Expense Line 141E 72320-399

C. Frontline Annual Renewal; Substitute Management System & HR Hiring System; Effective 7/1/2025 - 6/30/2026; \$62,352.08; Line Item 141E 71100-399

D. FY25 Dietary Budget Amendment

E. Monthly Financials

F. Matching Grants Approval (Board of Education funds required)

1. *Electric Bus Grant* (matching fund \$94,000 to \$220,000); Electric Bus with charging station to be housed at Jonesborough Elementary.

***School-Based Mental Health Services Grant* (matching fund \$50,000 per year for 5yrs); Salaries for 2 Interventionists, focusing behavioral support to tier 2 students.**

***Community Oriented Policing Services (COPS)* (matching fund \$166,667 over 3-years); School Safety, fencing, bullet resistance film to put over the glass, addition support/equipment for WCSO SRO's as needed.**

VI. Operations

A. Lewis Group Architects

Paul McCall with the Lewis Group was present as well as the mechanical engineer Rusty Whillock. They provided the plan for the boiler room project at Daniel Boone High School. It was noted extra capacity for classroom additions were included. The drawings will be complete next month and will be ready to release bids late April.

B. Review of gym floor bids (Lamar Elementary and David Crockett High)

VII. Student Supports

VIII. Superintendent

A. TISA Outcome-Based Funds Allocation

Mr. Boyd explained initiating a process of allowing the funds to go to the schools as a result of their outcomes.

B. Classroom Furniture Replacements

Mr. Boyd said the need for classroom furniture upgrades need to be looked at. Addressing the most needs, the high schools.

Discuss Policy 3.208: Community Use of Facilities

The Board discussed amending the policy to including the by-laws of non-school system organizations that utilize school properties.

D. Overnight Trip Requests

1. Daniel Boone High School

Nashville, TN

Band

April 10th-13th, 2025

Duration: 4 days

2. David Crockett High School

Knoxville, TN

Girls Volleyball

August 22nd-23rd, 2025

Duration: 2 days

3. David Crockett High School

Matthews, NC

Track & Field

April 26th-27th, 2025

Duration: 1 Day

4. David Crockett High School

Greeneville, OH

Ag-Sheep Show & Sale

May 7th-9th, 2025

Duration: 2 days

5. David Crockett High School

Cookeville, TN

Ag-State Nursery & Landscape Contest

April 21st-22nd, 2025

Duration: 1 day

IX. Resolution to Meet Requirement for Teacher Bonuses Under Education Freedom Scholarship Act

X. FY26 General Purpose Schools Budget Development Updates

Mr. Boyd shared the initial budget list of items. Included in discussion were the coaching/activity sponsor supplements and redesigning the structure. A scaled based on experience and to get back in line comparable to area school systems.

XI. Adjournment

School	-2	-1	0	1	2	3	4	5	6	7	8	9	10	11	12	Total
Boones Creek Elementary School	39	26	83	109	82	94	81	101	78	89	69	0	0	0	0	851
Daniel Boone High School	0	0	0	0	0	0	0	0	0	0	0	291	279	278	224	1072
David Crockett High School	0	0	0	0	0	0	0	0	0	0	0	278	284	275	204	1041
Fall Branch Elementary School	0	0	21	32	22	26	36	25	25	23	41	0	0	0	0	251
Gray Elementary School	0	18	64	60	52	61	50	56	57	49	55	0	0	0	0	522
Grandview Elementary School	4	23	74	59	67	58	70	56	49	62	65	0	0	0	0	587
Jonesborough Elementary School	0	18	93	117	104	120	112	91	104	100	118	0	0	0	0	977
Lamar Elementary School	0	23	43	43	53	49	33	35	42	47	42	0	0	0	0	410
Ridgeview Elementary School	5	11	54	64	88	76	80	69	89	98	80	0	0	0	0	714
South Central Elementary School	0	0	14	20	19	23	28	19	11	19	18	0	0	0	0	171
Sulphur Springs Elementary School	0	0	40	35	37	50	35	53	40	44	39	0	0	0	0	373
University School	0	0	20	21	19	20	24	47	52	52	52	86	83	84	76	636
West View Elementary School	2	0	29	23	29	29	31	38	29	30	33	0	0	0	0	273
Total	50	119	535	583	572	606	580	590	576	613	612	661	657	651	506	7911

3/4/2025	1	SCES	4/2/2025	4 hrs	Quantum Leap 117 E King St, Johnson City, TN 37601
3/5/2025	1	DBHS	4/8/2025	5 hours	Northeast State and La Caretta in Gray
3/5/2025	1	DBHS	3/31/2025	6 hours	Hospitality Works at Meadowview Conf Center in Kingsport
3/5/2025	1	SSES	5/8/2025	4.5 hours	Barter Theater in Abingdon, VA
3/21/2025		BCES	5/5/2025 [6]	5 hours	Pathfinders - Kingsport TN
3/6/2025	1	BCES	5/6/2025	5 hours and half [8]	Pathfinders - Kingsport TN
3/6/2025	9	BCES	5/19/2025	4 hours	Quantum Leap
3/6/2025	1	GES	4/24/2025	4 hours 45 minutes	Barter Theatre
3/6/2025	1	RVES	3/31/2025	5	ETSU Mini Dome
3/7/2025	1	BCES	5/8/2025	6 hours	Doe River Gorge 220 Doe River Gorge Rd, Hampton TN 37658
3/7/2025	1	RVES	5/15/2025	5.5 hours	Pathfinders
3/7/2025	1	DBHS	3/31/2025	6 hours	ETSU Minidome
3/7/2025	1	FBES	5/7/2025	4.5	Barter Theatre
3/10/2025		GES	5/13/2025	6hr 45 min	Appalachian Fair Grounds - Masonry Field Day
3/10/2025		JES	5/15/2025	1 hour	DCHS
3/10/2025		GVES	5/8/2025	6 hours	Clyde Austin 4-H Camp 214 4-H Lane, Greeneville, TN 37743
3/10/2025		DBHS	3/20/2025	1 Instructional Day	Eastern Region 4-H Livestock Judging Contest
3/10/2025		SSES	5/15/2025	5 hours	Rocky Mount, Piney Flats TN
3/10/2025		FBES	5/20/2025	5 hours	Warrior's Path
3/11/2025		DCHS	4/23/2025	2 hr. 15 min	Jonesborough Methodist Church - downtown
3/11/2025		BCES	4/16/2025	3.5 hours	Bright's Zoo
3/11/2025		DBHS	4/16/2025	3 hours 45 minutes	Jonesborough Kiwanis Club Meeting
3/12/2025		LES	5/5/2025	2.5 Hours	David Crockett High School
3/13/2025		SSES	3/19/2025	5.5	Northeast State Community College and Daniel Boone HS
3/13/2025		BCES	5/13/2025	2 hours 45 min	Quantum Leap, Johnson City
3/13/2025		RVES	5/9/2025	4 hours	Warpath Bowling Lanes, 2449 Memorial Blvd, Kingsport, TN 37664
3/14/2025		DCHS	4/5/2025	10.5 hours	Happy Valley High School - District Tournament Speech, Drama, Debate
3/14/2025		LES	5/14/2025	4 hours and 45 minutes	Hands On Discovery Center (Gray Fossil Site)
3/14/2025		WVES	5/7/2025	6 Hours	Quantum Leap and Willow Springs Park
3/14/2025		DBHS	5/8/2025	6.5 hrs	Tusculum University
3/15/2025		GVES	5/15/2025	4.5 Hours	Holiday Lanes & Willow Springs Park
3/17/2025		JES	5/13/2025	5.25 Hours	Holiday Lanes - 117 Broyles Drive Johnson City, TN 37604 Rotary Park- 1001 N. Broadway Johnson City, TN 37601
3/17/2025		DBHS	4/25/2025	3 days	Summit High School - 1776 Declaration Way, Thompson's Station, TN 37179
3/17/2025		Asbury	4/4/2025	2 hrs	Johnson City Chamber of Commerce, 602 Sevier Street, Johnson City TN 37604
3/17/2025		WVES	5/8/2025	12 hours	Dollywood for Beta Club
3/18/2025		GVES	5/15/2025	4 hours	Wallabies, Johnson City, TN
3/31/2025		GES	4/24/2025	4 Hours	Barter Theatre Abingdon VA
3/18/2025		DBHS	3/29/2025	9 hrs	ETSU
3/18/2025		DBHS	3/30/2025	6 hours	ETSU
3/18/2025		DBHS	3/29/2025	6 hours	ETSU
3/18/2025		GVES	4/15/2025	2 hours	Jonesborough Papa Johns
4/1/2025	7	GVES	4/22/2025	2 hours	Jonesborough Papa Johns [45]
3/18/2025		BCES	5/13/2025	4.5 hours	Tipton Haynes
3/19/2025		SSES	3/19/2025	5 hours	Northeast State and RCAM in Kingsport
3/19/2025		BCES	5/13/2025	4 hours	Tie Breakers
3/19/2025		DCHS	5/21/2025	4:45	Bright's Zoo
3/19/2025		WVES	5/14/2025	6 hours	Bays Mountain, Kingsport TN
3/19/2025		BCES	5/6/2025	5 Hours	Bays Mountain Park: 853 Bays Mountain Park Rd, Kingsport, TN 37660
3/20/2025		LES	5/13/2025	4.5 hours	Papa John's and Golden Oak Park in Jonesborough
3/20/2025		LES	3/31/2025	5 hr. 40 mins	Special Olympics at ETSU Mini Dome

3/20/2025	LES	5/13/2025	5 1/2 hours	Jackson Theater and Pizza Plus in Jonesborough
3/21/2025	DCHS	5/21/2025	5 hours	Brights Zoo 3425 Hwy 11 E, Limestone, TN, 37681, USA
3/29/2025	FBES	5/14/2025	4 hrs	Appalachian Caverns 420 Cave Hill Road Blountville, TN 37617
3/29/2025	DCHS	5/16/2025	6.25	ETSU Mini-Dome
3/30/2025	DCHS	4/25/2025	13 hours 15 minutes	McKinney Center, Jonesborough
3/30/2025	DCHS	5/16/2025	4 hours	ETSU Mini Dome (Graduation Rehearsal)
3/31/2025	GES	5/8/2025	5 hours	Rocky Mount Living Museum, Piney Flats, TN
3/31/2025	SCES	5/13/2025	5 hours	The Appalachian Fairgrounds, Gray, TN
3/31/2025	GES	4/3/2025	5 hr and 30 min	Brights Zoo and Willow Springs
3/31/2025	DCHS	4/24/2025	9	Tri State Antique Power Association Tractor Show - Appalachian Fairgrounds
4/1/2025	8 DBHS	4/30/2025	3 hours 45 minutes	Jonesborough Kiwanis Club Meeting
4/1/2025	1 SCES	5/5/2025	3 hrs	David Crocket High School
4/1/2025	1 GVES	5/21/2025	3.75 hours	Brights Zoo
4/1/2025	1 DCHS	4/16/2025	7 Hrs	McDowell H.S., Marion, NC
4/1/2025	1 DCHS	5/2/2025	5.5 Hrs	Daniel Boone H.S. Gray, Tn
4/1/2025	1 DCHS	5/19/2025	14 hours	Dollywood
4/1/2025	1 WVES	5/7/2025	6 hours	Quantum Leap and Willow Springs Park
4/2/2025	1 DBHS	5/16/2025	6 hours	ETSU
4/2/2025	1 SCES	5/12/2025	5 hours	Appalachian Caverns
4/2/2025	1 DBHS	5/7/2025	10 hours	Dollywood, Pigeon Forge, TN
4/2/2025	1 SSES	5/2/2025	3 hours	Bristol Caverns 1157 Bristol Caverns Hwy Bristol, TN 37620
4/2/2025	1 WVES	5/19/2025	5 hours	Tiebreakers and Willow Springs Park
4/2/2025	1 FBES	4/29/2025	4.5 hours	Barter Theater- Abingdon Virginia

Intent to Apply/Research	Grants Writer/Manager's Report	April 2025						
Electric Bus	<p>Central States quote: 155Kw (STD Range) \$373,694.00. Infrastructure: The cost of the Evolution charging station is \$5373 quote. BridgeRidge's estimated cost is \$10,775.00 to connect one charging station at BCE. Two grants to pursue: 1. EPA Clean School Bus (CSB) Rebate Program (federal) due Jan 14th. One School Board member must sign the 2024 CBS Rebate Program School Board Awareness Certification, an example here, for the application. Buses serving school districts that are not prioritized ZE class 7 bus UPTO \$170,000 (bus + charging Infrastructure.) 2. VW STATE GRANT is opening in January. - 75% towards the purchase of a new bus, and that would include infrastructure. The plan is to stack the general and federal awards to pay for the bus and infrastructure. These are matching grants; if only one is awarded, we and/or WCG will need to match the remainder of the funds for the project. Update: The EPA grant has been submitted.</p>							
TREE GRANT	<p>For the other schools not included in the TAEP Community Tree Planting Grant to provide tree shade for community members and students in sporting areas and near school buildings.</p>							
SPARK Equity PE grant	<p>Equipment to support PE classes districtwide for grades K-2</p>	<p>Update: The grant application has been submitted.</p>						
School-Based Mental Health Services Grant Program	<p>SMHS grant application will support the salaries of two Behavioral Interventionist, focusing on Tier II Behavioral support.</p>		<p>This forecasted grant opportunity requires non-Federal matching funds amounting at least 25% of their total project budget. This requirement promotes the sustainability of school-based mental health services. The budget that is being suggested for two Behavioral Intervention Specialists equals \$180,000-\$200,000 per year for 5 years. That would be a \$45,000-\$50,000 match (local funds) per year for 5 years. Please approve the 25% match requirement.</p>					
Community Oriented Policing Services (COPS) School Violence Prevention Program (SVPP)	<p>The forecasted grant opportunity is three years (36 months) in duration for a maximum federal share of \$500,000 per award. There is a local cash match (cost share) requirement of at least 25 percent. The grant would be for \$666,666 total with \$500,000 being the federal grant and \$166,667. The district is looking into funding support for fencing and window bullet-resistant film for the schools' doors and windows. Please approve the 25% match requirement.</p>							
STOP School Violence Program	<p>This grant forecast has been paused. When forecasted will consider applying for funding possibilities to support a mental health specialist(s) working with our School Resource Officers. This grant is a federal grant over 3 years.</p>							
Project Diabetes	<p>The State funds projects that utilize one or more of the performance goal strategies listed below to achieve the overarching goals of the Project Diabetes Initiative. "Category A" grants - Applicants may apply for a grant of up to three (3) years with funds not to exceed \$150,000 per year, for a maximum total of \$450,000.</p>	<p>The State funds projects that utilize one or more of the performance goal strategies listed below to achieve the overarching goals of the Project Diabetes Initiative. The State awarded competitive grants in two categories: Making physical activity an integral and routine part of life for all Tennesseans. After selecting goal(s), grantees address a strategy or strategies that they will take to achieve the selected goal. Strategy 2.5: Bicycle path, lanes & tracks - Accommodate or provide dedicated space for bicyclists via bicycle paths, lanes, cycle tracks, or protected bike lanes, etc. <i>West View walking track and David Crockett walking trails</i> Strategy 2.6: Places for physical activity - Modify local environments to support physical activity, increase access to new or existing facilities for physical activity. <i>David Crockett and Ridgeview would have Pickleball Courts. Intent to apply due March 7th and this would lead to an invitation to apply if chosen. UPDATE: HAVE BEEN APPROVED TO APPLY FOR THE GRANT</i></p>						

Perkins V Reserve Grant	Grant upto \$50,000	Revised: If we expand opportunities for students to secure NCCER industry credentials by supplying targeted study materials alongside hands-on, career-driven programs built for real-world success, then our students will be equipped to pursue early postsecondary pathways, dive into work-based learning, and land top-tier internships, building their futures and paving the way for stackable credentials that support advanced degrees and high-skill careers, with the resources to master skills and excel from day one.			Funding for Industry Credentials	Intent to Apply March 21, 2025	Intent submitted. We will be applying for the grant		
SCORE Future Forward Innovation Grant	Future Forward Innovation Grant application proposes an in-house TAP Practicum Internship Pilot to provide high school seniors with structured, immersive teaching experiences in elementary and middle school classrooms. This initiative strengthens the teacher pipeline by offering hands-on training, professional mentorship, capstone project funding, and postsecondary pathways.					Application due April 11, 2025			
Youth Endowment Fund	For Playground Communication Boards	Upto \$20,000	Open April 15, 2025 Closes; May 12 ,2025						
Grants Awarded									
Grants Managed									
Reduced Diesel Emissions for a Healthier Tennessee	Work with Washington County Government to receive \$44,000 award toward two propane buses			This grant award is on hold due to the Government					
Education Stabilization Fund - ESSERF Data Collection	Annual Reporting: This report should be completed based on activities in each state's fiscal year 2023 for ESSER 1.0, ESSER 2.0, and ESSER 3.0, respectively. Due dates will be determined close to the date of publication of the final template in the Federal Register.			ESSER 2.0 Year 4 Annual Report Period July 2023 - June 30, 2024	Open: February 19, 2025	Close: April 18, 2025	ESSER 3.0 Year 4 Annual Report Period July 2023 - June 30, 2024	Open: February 19, 2025	Finished and submitted.
Uniformed Grant Guidance	Worked on revising Uniformed Grant Guidance to include recent changes to Federal Grants Management Rules.			Finished.					

TVA STEM Classroom Grant	Jared Smith's grant proposal for Jonesborough Elementary School in the amount of \$5000 for the project "Eye of the Tiger Film and Digital Media Club"		I am the fiscal contact, and assist with all purchasing of items within their budgets.	All purchases have been met.		
ESSER Federal Interest Reporting and Recording	Provide individually a Real Property Status Report Attachment A SF-429-A report of which all schools received ESSER funds for capital projects		In addition to 429A reporting, both DBHS and DCHS properties, which have projects over \$1 million, will require Federal Interest Recording, which is a legal document we create and submit to the Washington County Register of Deeds office.		Turned in Federal Interest Reporting and 429 Reporting, Dec. 2024	
TAEF Community Tree Planting Grant	Funds expended prior to the start date are not reimbursable. The expected start date is 12/1/2024.		awarded \$4235.79 of \$8471.58 cost of project	50:50 match grant awarded on October 21, 2024, provided by TN Department of Agriculture: Division of Forestry	Will assist fiscal and reporting with Grounds supervisor	3 year reporting
Title XI McKinney-Vento Subgrant Hurricane Emergency Relief	Awarded \$14,000	Items of need to be purchased for students who have become displaced due to Helene.	Students must be identified as McKinney-Vento Homeless due to Helene to receive items of need provided by the funding...such as school items and essential personal items such as clothing, food, hygiene products, portable sleeping items.		Working with the Homeless Liaison	Grant funding has been expended.
ETSU SLICE - SL Partnership STEM LITERACY COMPUTATION IN EDUCATION WITH SCHOOL LEADERS	ETSU federal government grant we have partnered	Currently processes quotes and POs for procurements of the minigrants for participating schools' teams. Total award is appx. \$81,000 in materials, equipment, and supplies.	I am the Co-PI-LEA CONTACT for Washington County	Financial reimbursements invoices and execution of purchases with schools' classroom minigrants that will be provided at the end of year 2 grant term and any other needs that may occur.	The mini-grant portion of the SLICE grant is complete. The Federal Government closed the Grant in February 2025. In March 2025, it was reinstated, and grant fulfillment will continue.	
ISM Grant	Currently helping CTE Director write FY 25 ISM application. We have submitted the continual application, grant is approved for the new school year.	Assist CTE Director when needed	Note: schools involved in this grant were awarded (allocated FY2023) BCE \$500,000, DB \$1,000,000, DC \$1,000,000, FB \$200,000, GV \$500,000, Gray \$500,000, JES \$500,000, RV \$500,000, SC \$200,000, SS \$500,000, University \$1,000,000, WV \$500,000			
FY 2025 - CTE Perkins Reserve	Awarded \$50,000 for Daniel Boone CTE program in connection with Culinary ARTS and certain populations		Will assist CTE Director with any needs in managing the grant.			
LEAPS PROGRAM	Start new school year, this is year 5 of the program	UPDATED EPLAN BUDGET \$75,000	Provide all necessary documentation into Department of Human Services Child Care Provider Portal to renew the SCES LEAPS site for continuing service	Help with any grant related to personnel, data reporting, purchases and attend meetings with the state department.		
ESSER 3.0	Continual reporting to state department: ESSER 3.0 funds		We will be generating the ESSERF report for the Fiscal year July 2023- which was reimbursed by the state by June 30, 2024. Starting in winter/spring 2025.		ESSERF submitted.	

ARP 2.0 Homeless Grant	FY 25 purchasing food, clothing, hygiene products	In collaboration with the Director of Attendance/ Chief Student Supports Officer.	Providing purchasing and documentation support.	HELP WITH REPORTING	help with any grant related reimbursement request documentation	Grant was approved for an extended liquidation and the funding is complete.
------------------------	---	---	---	---------------------	---	---

Monthly Facility Tracker reports

All Locations -

<https://facilitytracker.app-garden.com/Woms/PublicAnalytic/Index?guid=af78549c-6e53-41e9-afec-dd4d8bfa815d>

WVES -

<https://facilitytracker.app-garden.com/Woms/PublicAnalytic/Index?guid=7061e70d-ee81-4bbe-a0a9-333ee6630ce4>

SSES -

<https://facilitytracker.app-garden.com/Woms/PublicAnalytic/Index?guid=82641ccd-b40b-406e-9593-f1f5d6d454ea>

SCES -

<https://facilitytracker.app-garden.com/Woms/PublicAnalytic/Index?guid=f4112e8b-ace7-42c8-83ce-ce7cca700d0a>

RVES -

<https://facilitytracker.app-garden.com/Woms/PublicAnalytic/Index?guid=abece4e4-3aaf-4e20-afb9-e7a4b253e7ea>

LES -

<https://facilitytracker.app-garden.com/Woms/PublicAnalytic/Index?guid=03c462a1-53fd-429c-8d8a-862353a095d4>

JMS -

<https://facilitytracker.app-garden.com/Woms/PublicAnalytic/Index?guid=047f5116-d265-4220-bca1-d51fd1f24df6>

JES -

<https://facilitytracker.app-garden.com/Woms/PublicAnalytic/Index?guid=3c2e5fd0-4dc5-4a44-b1a8-7ff0bc15c27e>

GES -

<https://facilitytracker.app-garden.com/Woms/PublicAnalytic/Index?guid=ef3d7048-0b99-4548-9f31-04632f0fae84>

GVES -

<https://facilitytracker.app-garden.com/Woms/PublicAnalytic/Index?guid=e2b27430-f9cb-4618-8958-f37a78a60a75>

FBES -

<https://facilitytracker.app-garden.com/Woms/PublicAnalytic/Index?guid=b9027fb8-5461-4cad-a2ca-4cd8a33ecfbe>

DCHS -

<https://facilitytracker.app-garden.com/Woms/PublicAnalytic/Index?guid=88424530-f628-46ae-8852-1a2d40bc9785>

DBHS -

<https://facilitytracker.app-garden.com/Woms/PublicAnalytic/Index?guid=1f5402fa-95ef-4b85-bc13-1b2a390eadd8>

BCES -

<https://facilitytracker.app-garden.com/Woms/PublicAnalytic/Index?guid=475154ae-7197-4f43-8ec4-6b9764458>

[b84](#)

Midway -

<https://facilitytracker.app-garden.com/Woms/PublicAnalytic/Index?guid=ec7f00ea-3b78-41db-9542-060401a41>

[1e6](#)

Bus Garage -

<https://facilitytracker.app-garden.com/Woms/PublicAnalytic/Index?guid=13f0ab1b-e7e9-4a01-bbeb-9b2d5181fb5f>

Warehouse -

<https://facilitytracker.app-garden.com/Woms/PublicAnalytic/Index?guid=7da489ac-1553-4a46-a0ac-27646726a003>

Central Office -

<https://facilitytracker.app-garden.com/Woms/PublicAnalytic/Index?guid=fbf02e24-8b01-46d9-98d1-a5e123581838>

Washington County Department of Education
School Educational **OVERNIGHT** Trip Authorization*

MAR 05 2025

BY: KR

Date of Request 3-4-25 School DBHS Trip Date 4/10-4/13

Estimated time of departure 8am 4/10 and return 4/13 6pm total time away 4 days
(2 school days)

Destination (include location) Opryland Hotel - Nashville, TN

Teacher Scott Blanton Class Band Grade 9

Melissa Powers Chorus 10-12

Chaperones Scott Blanton

Number of Students Involved 4

Melissa Powers

Estimated Total Miles (both ways) of Trip 560

Bus Driver/Number Taking School Van Bus Driver/ Number _____

Will Chaperones have a list (roll) that they are responsible for? yes

As you plan the trip, will all children be given instructions as to what they should do if they become separated (lost) from the group? yes

Will you have on file parental release forms signed by parents or legal guardians? yes

Explain the educational value of the trip: Our students auditioned and earned a high enough score to be selected for All-State Band/Chorus.

Total Cost Estimate \$3800⁰⁰

Plans for meeting the costs School Board + Band + Choral Boosters

Transportation cost for educational trips shall be calculated in the following manner:
\$16.00 per hour for driver (2 hour minimum)
\$ 3.15 per hour to cover fixed charges (SS, retirement, etc.)
\$19.15 total to be remitted to the central office per hour

Reimbursement for the bus and fuel shall be made at the rate of \$.75 per mile.
*Refer to Board Policy 4.302

Principal's Signature [Signature]

Date 3/5/25

APPROVED

BY WC SUPERINTENDENT [Signature]
Superintendent's Signature

Date 3/5/25

Date Approved by the Board of Education _____

RECEIVED

WASHINGTON COUNTY DEPARTMENT OF EDUCATION

Jonesborough, Tennessee

MAR 04 2025

BY: RP

School Educational **OVERNIGHT** Trip Authorization*

2/27/2025

Date of Request

School David Crockett High School Date of Trip August 22-23, 2025

Estimated Time of Departure Aug 22nd, 11am and Return Aug 23rd 10pm

Total Time Away 36 hours

Destination(include location) Knoxville, TN Knoxville Convention Center + Worlds Fair Hall

Teacher Tucker Knouse Amy Pleasant Class Girls Volleyball Grade 9th-12th

Chaperones Ashton Hippenstiel Number of Students Involved 25

Tucker Knouse Amy Pleasant Estimated Total Miles (Both Ways) of Trip 180 miles

Bus Driver Jerry Day Bus Number _____

Will the chaperones have a list (roll) that they are responsible for? yes

As you plan the trip, will all children be given instructions as to what they should do if they become separated (lost) from the group? yes

Will you have on file parental release forms signed by parents or legal guardians? yes

Explain the educational value of this trip:
To represent DCHS in a positive way at a diverse site, in a competitive athletic environment. Players will work together to accomplish a common goal by competing in the sport of volleyball in hopes of pursuing a successful season.

Showdown at Sunsphere Tournament

Total Cost Estimate: ~ \$2,000

Plans for meeting the costs: Booster Club

Transportation cost for education trips shall be calculated in the following manner:

\$16.00 per hour for driver (2 hour minimum)

3.15 per hour to cover fixed charges (SS, Retirement, etc.)

\$19.15 Total to be remitted to the Central Office

Reimbursement for the bus and fuel shall be made at the rate of \$.75 per mile.

APPROVED

Ashley Davis

2.29.25
Date

*Refer to Board Policy 4.302

BY WC SUPERINTENDENT

Superintendent's Signature

[Signature]

3-10-2025
Date

Date Approved by the Board of Education

Washington County Department of Education
School Educational **OVERNIGHT** Trip Authorization*

MAR 11 2025

BY: (KR)

Date of Request 3/6/25 School DCHS Trip Date 4/26-4/27/25

Estimated time of departure 4/26 8am and return 4/27 5pm total time away 33 hours

Destination (include location) Warrior Stadium, Matthews, NC

Teacher Arturo Jaquez Class Track & Field / Grade 9-12

Nicole Piazza cross country

Chaperones _____

Number of Students Involved 14

Estimated Total Miles (both ways) of Trip 400

Bus Driver/Number utilizing vans Bus Driver/ Number _____

Will Chaperones have a list (roll) that they are responsible for? Yes

As you plan the trip, will all children be given instructions as to what they should do if they become separated (lost) from the group? Yes

Will you have on file parental release forms signed by parents or legal guardians? Yes

Explain the educational value of the trip: The Carolina Distance carnival is a

prestigious meet where our varsity cross country and distance track athletes will have the opportunity to gain

experience, hone their skills and challenge themselves alongside high-level competitors

Total Cost Estimate \$2,045

Plans for meeting the costs _____

We plan to utilize funds previously raised

Transportation cost for educational trips shall be calculated in the following manner:

- \$16.00 per hour for driver (2 hour minimum)
- \$ 3.15 per hour to cover fixed charges (SS, retirement. etc.)
- \$19.15 total to be remitted to the central office per hour

Reimbursement for the bus and fuel shall be made at the rate of \$.75 per mile.
*Refer to Board Policy 4.302

William Davis
Principal's Signature

3.7.25
Date

BY WC SUPERINTENDENT [Signature]
Superintendent's Signature

3/11/25
Date

Date Approved by the Board of Education _____

Washington County Department of Education
School Educational **OVERNIGHT** Trip Authorization*

RECEIVED

MAR 17 2025

BY: KR

Date of Request 3-13-25 School David Crockett Trip Date 5/1-5/9

Estimated time of departure 3pm on 5/1 and return 8pm on 5/9 total time away 2 days, 5 hours

Destination (include location) Ohio Showcase Sheep Show & Sale / Greenville, Ohio

Teacher Ford / Longner Class Ag Grade 9-12

Chaperones Jessica Ford

Number of Students Involved 7

Estimated Total Miles (both ways) of Trip 800

Bus Driver/Number N/A

Bus Driver/ Number N/A

Will Chaperones have a list (roll) that they are responsible for? Yes

As you plan the trip, will all children be given instructions as to what they should do if they become separated (lost) from the group? Yes

Will you have on file parental release forms signed by parents or legal guardians? Yes

Explain the educational value of the trip: Students who are members of the sheep showing team or interested in showing will attend this showcase show where they will meet with industry experts and explore top of the line genetics and show techniques. They will learn proper fitting techniques as well as proper show techniques.

Total Cost Estimate \$800

Plans for meeting the costs FFA Funds

Transportation cost for educational trips shall be calculated in the following manner:
\$16.00 per hour for driver (2 hour minimum)
\$ 3.15 per hour to cover fixed charges (SS, retirement. etc.)
\$**19.15** total to be remitted to the central office per hour

Reimbursement for the bus and fuel shall be made at the rate of **\$.75** per mile.
*Refer to Board Policy 4.302

Allyson Buech
Principal's Signature

3.14.25
Date

BY WC SUPERINTENDENT [Signature]
Superintendent's Signature

03/17/25
Date

Date Approved by the Board of Education _____

Washington County Department of Education
School Educational **OVERNIGHT** Trip Authorization*

RECEIVED

MAR 17 2025

BY:

KR

Date of Request 3-13-25 School David Crockett Trip Date 4/21-4/22

Estimated time of departure 8AM on 4/21 and return 8pm on 4/22 total time away 1 day, 12 hours

Destination (include location) State Nursery & Landscape Contest / Tennessee Tech University

Teacher Ford/Linger Class Ag Grade 9-12

Chaperones _____

Number of Students Involved 4

Estimated Total Miles (both ways) of Trip 400

Bus Driver/Number N/A Bus Driver/ Number N/A

Will Chaperones have a list (roll) that they are responsible for? Yes

As you plan the trip, will all children be given instructions as to what they should do if they become separated (lost) from the group? Yes

Will you have on file parental release forms signed by parents or legal guardians? Yes

Explain the educational value of the trip: Andrew Jaynes, Andrew Jenkins, Alden Erwin, and Elijah Pratt. It qualified to compete at the state Nursery & Landscape Contest. While competing, these students will demonstrate knowledge & skill that they have gained through coursework & contest prep.

Total Cost Estimate \$500

Plans for meeting the costs FFA Funds

Transportation cost for educational trips shall be calculated in the following manner:

\$16.00 per hour for driver (2 hour minimum)

\$ 3.15 per hour to cover fixed charges (SS, retirement, etc.)

\$**19.15** total to be remitted to the central office per hour

Reimbursement for the bus and fuel shall be made at the rate of **\$.75** per mile.

*Refer to Board Policy 4.302

Ashley Davis
Principal's Signature

3.14.25
Date

BY WC SUPERINTENDENT [Signature]
Superintendent's Signature

03/17/25
Date

Date Approved by the Board of Education _____

PURCHASING DEPARTMENT
WASHINGTON COUNTY BOARD OF EDUCATION

Purchase Order **No 4879**

Date Issued **3/17/25**

Appropriation No. **141-E-76100-707**

Dept. **ISM grant**

School **Grandview**

PURCHASE ORDER

TO Tailored closet
 4081 Hwy 11E
 Bluff City, TN 37618

Deliver to **Grandview Elementary**

Address **2891 US-11E**

Via **Telford, TN 37690**

Heather Shulton

Articles on this order must be charged to account of

NOTICE TO VENDOR

1. Purchase order **MUST** bear two signatures in order to be valid.
2. Purchase order number **MUST** appear on all invoices submitted for payment.
3. Mail **TWO** copies of your invoice promptly to:

Washington County Board of Education
 405 West College Street
 Jonesborough, TN 37659
 Telephone (423) 753-1105

ARTICLES OR SERVICES (Unless otherwise stated all prices F.O.B. Destination)	CODE	QUANTITY & UNIT	UNIT PRICE	TOTAL
New flooring				\$8,775.00
Removal of old flooring				\$2,200.00
*price inquiry attached				
GRAND TOTAL - INCLUDING ALL ATTACHED PAGES				\$10,975.00

SUBJECT TO THE FOLLOWING CONDITIONS

1. All packages, cartons or other containers must be plainly marked with the purchase order number.
2. The right is reserved to purchase in the open market and to charge the difference to the Vendor in the event that deliveries are not made at the time specified in the bid and on this order.
3. Whenever a delivery is rejected, the Vendor shall be notified and be given the reason for the rejection. All rejected deliveries shall be held at the Vendor's risk and he shall bear the expense of removal.
4. Acceptance of this order includes acceptance of all terms, prices, delivery, instructions, specifications and conditions stated.
5. The county is not liable for Federal excise tax or state sales tax.
6. Each shipment and/or each purchase order should be covered by separate invoice.

IMPORTANT: INVOICES AND PACKAGES MUST BEAR PURCHASE ORDER NUMBER

VENDOR'S COPY	There is an otherwise unincumbered balance to the credit of the proper appropriation, allotment or fund to meet the expenditure covered by this purchase.	APPROVED:
	Authorized Signature	Purchasing Agent



PRICE INQUIRY FORM

VENDOR	DESCRIPTION OF ITEM FOR PRICE COMPARISON	PRICE QUOTED
Firm - <u>Tailored Closet</u> Address- <u>4081 Hwy 11 E Bluff</u> City. <u>TN 37618</u> Person _____ Date - <u>3/17/25</u>	Removal of tile & adding new epoxy-like floor coating	Total: \$10,975.00
Firm: <u>Tri Cities Epoxy Floors</u> Address: <u>194 Tucker St. Gate</u> City. <u>VA 24251</u> Person- <u>Daniel Mitchell</u> Date - <u>3/17/25</u>	Classroom polyaspartic top coat, cove base, and fill in electrical boxes	Total: \$12,034.00
Firm - <u>Team Red Coatings</u> Address - Person- Date - <u>3/17/25</u>	Epoxy Floor Coating	Total: Team Red refused to give a quote until the current floor had been removed.

Name of person obtaining inquiry - Kelli Hauldren

P R O P O S A L

Tailored Closet-PremierGarage of Tri-Cities-TN, Boone,
Asheville
4081 Hwy 11 E
Bluff City, TN 37618
(423) 557-4450

<https://tailoredcloset.com/near-me/tri-cities-tn/>
<https://www.premiergarage.com/near-me/tri-cities-tn/>



Billing/Service Address

Heather Shelton
2891 US-11E
Telford, TN 37690
(423) 620-0062
sheltonh@wcde.org

Date	March 17, 2025
------	----------------

P G F L O O R I N G - D E C O R A T I V E F L A K E

This proposal expires on 3/31/2025

Prepared by Kade Honaker (kade.honaker@tailoredcloset.com)

N O T E S

Hey Heather!

Thank you for considering Premier Garage for your garage flooring needs. We are delighted to offer our expertise in providing high-quality, durable, and aesthetically pleasing flooring solutions that will transform your garage into a functional and visually appealing space.

Please look over the designs and proposal and let me know if you have any questions or any changes you'd like to see or how you want to proceed.

Should you choose to move forward with your project, and you have no further questions or changes, please read carefully the bullet points in the Terms & Conditions section, and then click on the orange "Accept" icon just below the total price. This will take you to the sign-off section. Type your name where requested, sign, and enter your credit card details for the 50% non-refundable deposit. Please let me know if you'd prefer to pay your deposit in some other manner, in which

case I need to make a slight change in order for the system to allow you to accept without providing credit card details.

We would tentatively schedule your installation (subject to receipt of materials and other circumstances outside our control) once we have received your acceptance and deposit. As of right now, the next available date is in the week of April 28th, but that can change pretty quickly.

If you have any questions, please give me a call or text me at 423-388-8151 or send me an email at the email address above.

Thanks!

This proposal contains 4 options. Be sure to click the checkboxes below for the options you want to include.

Item	Description	Room	Details	Rate	Amount
Installation - Garage Flooring	Flooring Installation				
<input checked="" type="checkbox"/> Floor and Cabinetry					\$28,100.00
Primary Closet	Handle Finish: Chrome Finish: Shadow Frost Accent Finish: Black Door Accent Finish: Shadow Frost Door Primary Style: Slab Door Handle Style: Bar Pull 156mm Door Hinge: Soft Close Floor Finish: Sedona	CTE Room	(1) Counter, 1" Laminate, Ebony Star (5) Counter 1" TFL, Black	28100.00	\$28,100.00
<input checked="" type="checkbox"/> Cabinetry Only					\$19,350.00
Home Office	Handle Finish: Chrome Finish: Shadow Frost Accent Finish: Black Door Accent Finish: White Door Primary Style: Slab Door Handle Style: Bar Pull 156mm Door Hinge: Soft Close	CTE Room	(1) Counter, 1" Laminate, Ebony Star (5) Counter 1" TFL, Black	19350.00	\$19,350.00

■ Flooring Only					\$8,775.00
PremierOne Decorative Textures Flooring	Please see selections below COLOR: Sedona FLAKE SIZE: 1/4 FLOOR SF: 1097 STEMWALL SF: N/A TOTAL SF: 1097 CURRENT CONDITIONS Existing Surface: Tile Cracking: Unknown Tramex Reading: N/A Joints: N/A Obstructions: Customer to remove all items from floor FLOOR COATING PLAN Moisture Barrier: None Stemwall: None Termination Point: Entire Room Apron: N/A	CTE Room	\$8 PER SQFT	8775.00	\$8,775.00
■ Removal of Flooring Only					\$2,200.00
Commercial Flooring	Please see selections below COLOR: Sedona FLAKE SIZE: 1/4 FLOOR SF: 1097 STEMWALL SF: N/A TOTAL SF: 1097 CURRENT CONDITIONS Existing Surface: Tile Cracking: Unknown Tramex Reading: N/A Joints: N/A	CTE Room	\$2 Per SQFT	2200.00	\$2,200.00

Obstructions: Customer to remove all items from floor FLOOR COATING PLAN Moisture Barrier: None Stemwall: None Termination Point: Entire Room Apron: N/A				
			Floor and Cabinetry	\$28,100.00
			Cabinetry Only	\$19,350.00
			Flooring Only	\$8,775.00
			Removal of Flooring Only	\$2,200.00
			Subtotal	\$58,425.00
			Tax	\$0.00
			Total	\$58,425.00

FINANCING

Split the cost into easy monthly payments with  HEARTH

As low as **\$1168.5/month** based on the price of \$58,425.00 at 0% annual percentage rate (APR) for the first 15 months.

Click [here](#) to see your monthly payment options.

- Instant prequalification
- Rates from 0% APR*
- Checking eligibility does not impact your credit score

*After 0% introductory period, your APR will be between 14.99%-29.99%, based on your creditworthiness. This APR will vary with the market based on the U.S. Prime Rate. Your monthly payment for the 0% options will be determined by creditworthiness. **All financing is subject to credit approval. Your terms may vary. Payment options through Hearth are provided by our lending partners. For example: a \$7,500 purchase could cost \$237/month for 36 months based on an 8.5% APR. Offers are based on creditworthiness.

P I C T U R E S



Bar Pull.png

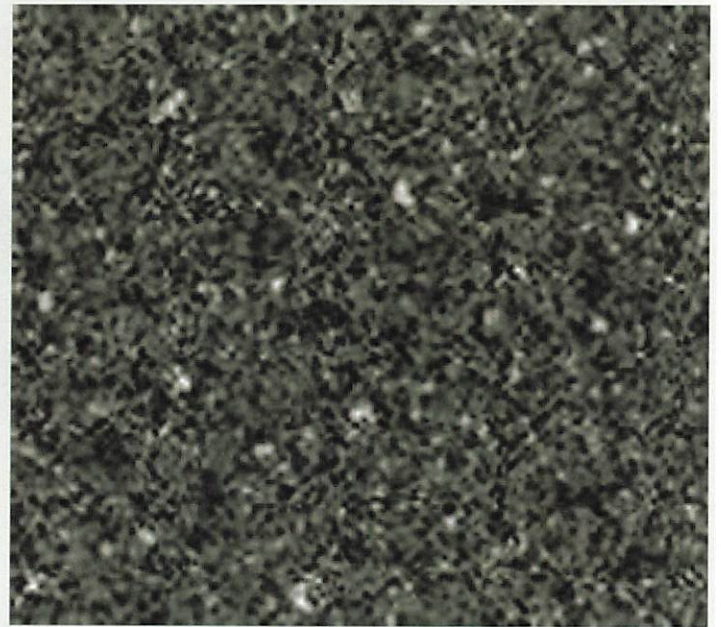

Magnified Image

Ebony Star Countertop.png

TFL COLOR PALETTE



TFL COLOR PALETTE.png

D O C U M E N T S

	Heather Shelton Grandview Designs 3-17-25.pdf
---	---

T E R M S A N D C O N D I T I O N S

Warranty Information:

**Floor Coating Systems: Tailored Closet Premier Garage ("TCPG") represents and warrants that

(i) the labor, and

(ii) the materials manufactured by or for TCPG used in the installation of your floor coating system is to be free from defects for as long as you own the property. This warranty is nontransferrable and applies only to the original buyer. Warrantable defects include staining from oil, transmission fluid or coolant, and peeling / delaminating.

Cabinetry/Closet Systems: TCPG represents and warrants that

(i) the labor, and (ii) the materials manufactured by or for TCPG used in the installation of your shelving/cabinet system(s) will be free from defects for as long as you own the property. This

warranty is non-transferrable and applies only to the original buyer. The above warranties exclude the following:

- Any exterior Floor Coatings, such as the apron of the garage floor that extends beyond the garage door, or coating of vertical surfaces or wood surfaces.
 - Damage caused by improper maintenance or repair, abuse, misuse, fire, water, acts of nature or other events beyond TLPG's control including, but not limited to, holes cut or drilled into Tailored Living products, and damage caused by removal or improperly maintaining the floors and/or cabinetry.
 - Damage to shelving/cabinetry caused by water or other liquids, i.e., spillage, rain, flood, etc.
 - Attempted repair or removal of TCPG products by anyone other than TCPG or its authorized dealers.
 - Damage, including dulling of the finish, due to improper cleaning methods.
 - Products that are not manufactured by or for TCPG for sale to & installation by its authorized dealers.
 - Products that have not been installed by TCPG or its authorized dealers.
 - Products that have not been paid for in full by buyer.
 - Floor Coating damage caused by a hydrostatic water problem, moisture vapor permeating the concrete slab, or exposure to battery acid or other highly corrosive chemicals.
-
- Floor Coating delamination caused by improper substrate condition, or an internal failure of the substrate.
 - Cracks in the substrate prior to or occurring after the installation of the Floor Coating system that appear from normal ground shift and expansion / contraction of the substrate, including cracking or bulging of joint fillers.
 - Scratching of the Floor Coating due to dragging or sliding heavy or sharp items across the floor coatings.
 - Floor Coating staining from tires ("plasticizer migration")
 - Rust stains appearing above, within, or below the Floor Coating.

Proof of purchase is required when making a warranty claim. All warranty claims must be in writing. To make a warranty claim, contact TCPG. TCPG will determine in its sole and absolute discretion, whether:(a) the floors and/or shelving/cabinets have been properly maintained, and (b) the warranties granted herein are applicable and not otherwise subject to the exclusions hereunder. If a claim is determined to be subject to the warranties hereunder, then TCPG will repair or replace the items subject to the claim at TLPG's expense. A claim hereunder will be your sole and exclusive

remedy. This warranty is non-transferable and applies only to the original buyer. This warranty may not be assigned or transferred.

EXCLUDING THE ABOVE, TCPG DISCLAIMS ALL EXPRESS AND IMPLIED WARRANTIES INCLUDING, BUT NOT LIMITED TO, WARRANTIES OF MERCHANTABILITY, FITNESS FOR A PARTICULAR PURPOSE, AND TRADE USAGE. FURTHERMORE, TCPG SHALL NOT BE LIABLE FOR ANY CONSEQUENTIAL, INDIRECT, INCIDENTAL, SPECIAL, PUNITIVE, OR EXEMPLARY DAMAGES (INCLUDING, BUT NOT LIMITED TO, DAMAGE TO PERSONAL PROPERTY, LOSS OF TIME, LEGAL SERVICES, OR TRAVEL) WHETHER OR NOT ADVISED OF THE POSSIBILITY OF THE SAME AND WHETHER OR NOT BASED IN WARRANTY, CONTRACT, INDEMNITY, TORT (INCLUDING, BUT NOT LIMITED TO, NEGLIGENCE), OR ANY OTHER THEORY OF LAW OR EQUITY.

Click [here](#) if you no longer wish to receive notifications or related information about this proposal.

Invoice

Tax invoice



Tri Cities Epoxy Floors , 194 Tucker St , Gate City VA 24251, United States

BILL TO

Grandview Elementary
2891 Highway 11 E
Telford TN
United States

Invoice No.: 162
Issue date: Mar 5, 2025
Due date: Mar 18, 2025
Payment method: Check/cheque

Invoice No.: 162	Issue date: Mar 5, 2025	Due date: Mar 18, 2025	Total due (USD) \$12,034.00
----------------------------	-----------------------------------	----------------------------------	---------------------------------------

Description	Qty.	Unit price (USD)	TAX (USD)	Amount (USD)
Classroom Mechanical diamond grind Flood coat to cover existing floor Receiver coat Full broadcast 1/4" flake Polyaspartic top coat	1.0	7,924.00	0.00	7,924.00
4" epoxy cove base 4" epoxy cove base installation Coat cove base and broadcast flake to match floor Seal cove base	1.0	2,860.00	0.00	2,860.00
Fill in electrical boxes Fill in electrical boxes on floor	10.0	125.00	0.00	1,250.00
Subtotal				\$12,034.00
Total (USD)				\$12,034.00

Daniel Mitchell

4234802104

Tri Cities Epoxy Floors
194 Tucker St
Gate City VA 24251
United States

Team red communication

1 message

Heather SHELTON <sheltonh@wcde.org>
To: Kelli Hauldren <hauldrenk@wcde.org>

Mon, Mar 17, 2025 at 3:56 PM

4 attachments



IMG_4235.PNG
666K



IMG_4233.PNG
352K



IMG_4234.PNG
3081K



IMG_4237.PNG
3323K

Team Red stated they
do not remove concrete &
wouldn't provide an estimate
until the concrete is removed.

PURCHASING DEPARTMENT
WASHINGTON COUNTY BOARD OF EDUCATION

Purchase Order **№ 4880**

Date Issued **3/17/25**

Appropriation No. **141-E-76100-707**

Dept. **ISM grant**

School **Grandview**

PURCHASE ORDER

TO Preston Woodworking
 720 Rolling Hills Dr.
 Johnson City, TN 37604

Deliver to **Grandview Elementary**

Address **2891 US-11E**
Telford, TN 37690

Via **Heather Shelton**

Articles on this order must be charged to account of

NOTICE TO VENDOR

- 1. Purchase order MUST bear two signatures in order to be valid.**
- 2. Purchase order number MUST appear on all invoices submitted for payment.**
- 3. Mail TWO copies of your invoice promptly to:**

Washington County Board of Education
405 West College Street
Jonesborough, TN 37659
Telephone (423) 753-1105

ARTICLES OR SERVICES (Unless otherwise stated all prices F.O.B. Destination)	CODE	QUANTITY & UNIT	UNIT PRICE	TOTAL
Plastic laminate cabinets				\$15,917.00
*price inquiry attached				
GRAND TOTAL - INCLUDING ALL ATTACHED PAGES				\$15,917.00

SUBJECT TO THE FOLLOWING CONDITIONS

1. All packages, cartons or other containers must be plainly marked with the purchase order number.
2. The right is reserved to purchase in the open market and to charge the difference to the Vendor in the event that deliveries are not made at the time specified in the bid and on this order.
3. Whenever a delivery is rejected, the Vendor shall be notified and be given the reason for the rejection. All rejected deliveries shall be held at the Vendor's risk and he shall bear the expense of removal.
4. Acceptance of this order includes acceptance of all terms, prices, delivery, instructions, specifications and conditions stated.
5. The county is not liable for Federal excise tax or state sales tax.
6. Each shipment and/or each purchase order should be covered by separate invoice.

IMPORTANT: INVOICES AND PACKAGES MUST BEAR PURCHASE ORDER NUMBER

VENDOR'S COPY

There is an otherwise unincumbered balance to the credit of the proper appropriation, allotment or fund to meet the expenditure covered by this purchase.

Authorized Signature

APPROVED:

Purchasing Agent



PRICE INQUIRY FORM

VENDOR	DESCRIPTION OF ITEM FOR PRICE COMPARISON	PRICE QUOTED
Firm - <u>Preston Woodworking</u> Address- <u>720 Rolling Hills</u> <u>Drive Johnson City, TN 37604</u> Person - <u>Greg</u> Date - <u>3/17/25</u>	Plastic Laminate Casework for CTE Classroom	Total: \$15,917.00
Firm: <u>2 Squirrels Cabinets</u> Address: <u>3547 US 11-E</u> <u>Limestone, TN 37681</u> Person- <u>Jarrold Crum</u> Date - <u>3/17/25</u>	Wood Cabinets with laminate countertops for CTE Classroom	Total: \$22,228.00
Firm - <u>The Tailored Closet</u> Address - <u>4081 Hwy 11 E Bluff</u> <u>City, TN 37618</u> Person- Date - <u>3/17/25</u>	Cabinets for CTE Classroom	Total: \$19,350.00

Name of person obtaining inquiry - Kelli Hauldren



PRESTON

WOODWORKING

720 Rolling Hills Drive, Johnson City, TN 37604 Phone (423) 928-9331 Fax (423) 928-3958

Date: March 7, 2025
To: Washington County, TN Department of Education
Attn: Heather Shelton, Kelly Hauldren
From: Mike Banner
Re: Grandview Elementary School CTE Classroom
Includes: Quote

Plastic laminate base cabinets, wall cabinets, and countertops per site discussions with Heather Shelton. Sketch provided with this quote for clarity.

Approximate Linear Footage

Base Cabinets and Countertops	+/- 56'-0"
Wall Cabinets	+/- 38'-0"

\$15,917

Notes:

- Pricing reflects work being performed during our normal business hours of 8am – 4pm and includes installation.
- Shop drawings to be provided with approved quote.
- Please call with any questions.

GRANDVIEW LTE

HEATHER SHELTON

sheltonh@wcde.org

CABS: FORMICA 961-58 FOG

TOPS: SPECTRUM BLUE 851-58

*CORY KELLY HAULDREN

hauldrenk@wcde.org

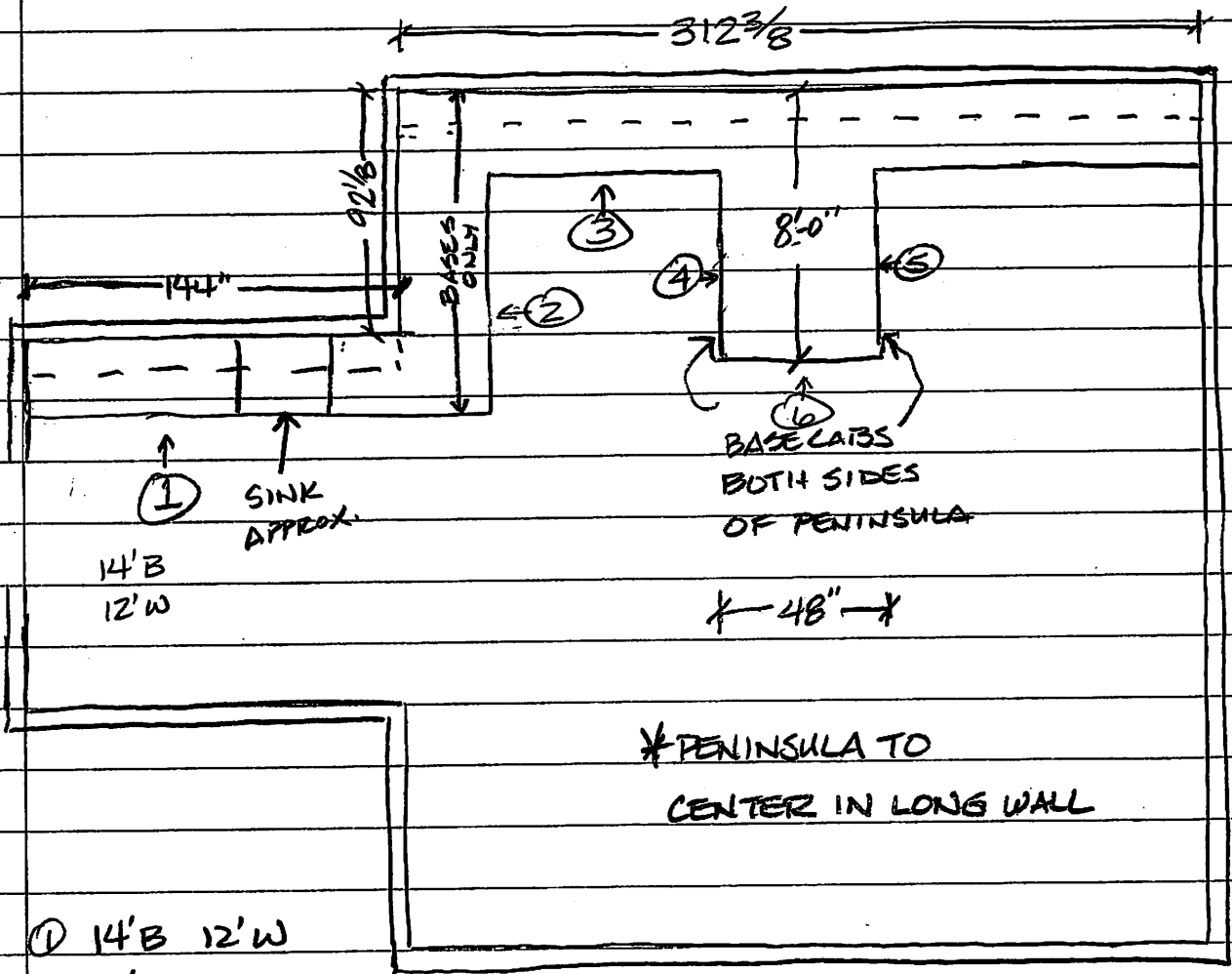

*PENINSULA TO
CENTER IN LONG WALL

① 14' B 12' W

② 6' B

③ 22' B 26' W

④ 6' B

⑤ 6' B

Fwd: cabinet quote

1 message

Heather SHELTON <sheltonh@wcde.org>
To: Kelli Hauldren <hauldrenk@wcde.org>

Mon, Mar 10, 2025 at 1:52 PM

Cabinet Quote #2

----- Forwarded message -----

From: jarrod crum <2squirrelscabinets@gmail.com>
Date: Mon, Mar 10, 2025 at 12:17 PM
Subject: cabinet quote
To: <sheltonh@wcde.org>

Proposal for cabinets

The price for the cabinets as pictured installed at grandview is \$22228.00 plus tax.

The scope of this work is to install the cabinets, install the laminate countertops with a cove rolled rounded edge. The cabinets will be of all wood construction, with slow close doors and drawers, dovetail drawers (for greater drawer life), and a kiln dried powder coat paint finish in one of our selected colors. The cabinet color and countertop color will have to be selected.

Jarrold Crum
Two squirrels Cabinets
423 972 1238

--
Heather Shelton
6-8 CTE/Stem
Grandview Elementary

5 attachments



grandview A03.jpg
1164K



grandview A01.jpg
1130K



grandview A04.jpg
1230K



grandview A05.jpg
1281K



grandview A06.jpg
1157K

P R O P O S A L

Tailored Closet-PremierGarage of Tri-Cities-TN, Boone,
Asheville
4081 Hwy 11 E
Bluff City, TN 37618
(423) 557-4450

<https://tailoredcloset.com/near-me/tri-cities-tn/>
<https://www.premiergarage.com/near-me/tri-cities-tn/>



Billing/Service Address

Heather Shelton
2891 US-11E
Telford, TN 37690
(423) 620-0062
sheltonh@wcde.org

Date	March 17, 2025
------	----------------

P G F L O O R I N G - D E C O R A T I V E F L A K E

This proposal expires on 3/31/2025

Prepared by Kade Honaker (kade.honaker@tailoredcloset.com)

N O T E S

Hey Heather!

Thank you for considering Premier Garage for your garage flooring needs. We are delighted to offer our expertise in providing high-quality, durable, and aesthetically pleasing flooring solutions that will transform your garage into a functional and visually appealing space.

Please look over the designs and proposal and let me know if you have any questions or any changes you'd like to see or how you want to proceed.

Should you choose to move forward with your project, and you have no further questions or changes, please read carefully the bullet points in the Terms & Conditions section, and then click on the orange "Accept" icon just below the total price. This will take you to the sign-off section. Type your name where requested, sign, and enter your credit card details for the 50% non-refundable deposit. Please let me know if you'd prefer to pay your deposit in some other manner, in which

case I need to make a slight change in order for the system to allow you to accept without providing credit card details.

We would tentatively schedule your installation (subject to receipt of materials and other circumstances outside our control) once we have received your acceptance and deposit. As of right now, the next available date is in the week of April 28th, but that can change pretty quickly.

If you have any questions, please give me a call or text me at 423-388-8151 or send me an email at the email address above.

Thanks!

This proposal contains 4 options. Be sure to click the checkboxes below for the options you want to include.

Item	Description	Room	Details	Rate	Amount
Installation - Garage Flooring	Flooring Installation				
<input checked="" type="checkbox"/> Floor and Cabinetry					\$28,100.00
Primary Closet	Handle Finish: Chrome Finish: Shadow Frost Accent Finish: Black Door Accent Finish: Shadow Frost Door Primary Style: Slab Door Handle Style: Bar Pull 156mm Door Hinge: Soft Close Floor Finish: Sedona	CTE Room	(1) Counter, 1" Laminate, Ebony Star (5) Counter 1" TFL, Black	28100.00	\$28,100.00
<input checked="" type="checkbox"/> Cabinetry Only					\$19,350.00
Home Office	Handle Finish: Chrome Finish: Shadow Frost Accent Finish: Black Door Accent Finish: White Door Primary Style: Slab Door Handle Style: Bar Pull 156mm Door Hinge: Soft Close	CTE Room	(1) Counter, 1" Laminate, Ebony Star (5) Counter 1" TFL, Black	19350.00	\$19,350.00

<input checked="" type="checkbox"/> Flooring Only					\$8,775.00
PremierOne Decorative Textures Flooring	Please see selections below COLOR: Sedona FLAKE SIZE: 1/4 FLOOR SF: 1097 STEMWALL SF: N/A TOTAL SF: 1097 CURRENT CONDITIONS Existing Surface: Tile Cracking: Unknown Tramex Reading: N/A Joints: N/A Obstructions: Customer to remove all items from floor FLOOR COATING PLAN Moisture Barrier: None Stemwall: None Termination Point: Entire Room Apron: N/A	CTE Room	\$8 PER SQFT	8775.00	\$8,775.00
<input checked="" type="checkbox"/> Removal of Flooring Only					\$2,200.00
Commercial Flooring	Please see selections below COLOR: Sedona FLAKE SIZE: 1/4 FLOOR SF: 1097 STEMWALL SF: N/A TOTAL SF: 1097 CURRENT CONDITIONS Existing Surface: Tile Cracking: Unknown Tramex Reading: N/A Joints: N/A	CTE Room	\$2 Per SQFT	2200.00	\$2,200.00

Obstructions: Customer to remove all items from floor				
FLOOR COATING PLAN				
Moisture Barrier: None				
Stemwall: None				
Termination Point: Entire Room				
Apron: N/A				

Floor and Cabinetry	\$28,100.00
Cabinetry Only	\$19,350.00
Flooring Only	\$8,775.00
Removal of Flooring Only	\$2,200.00
Subtotal	\$58,425.00
Tax	\$0.00
Total	\$58,425.00

F I N A N C I N G

Split the cost into easy monthly payments with  HEARTH

As low as **\$1168.5/month** based on the price of \$58,425.00 at 0% annual percentage rate (APR) for the first 15 months.

Click [here](#) to see your monthly payment options.

- Instant prequalification
- Rates from 0% APR*
- Checking eligibility does not impact your credit score

*After 0% introductory period, your APR will be between 14.99%-29.99%, based on your creditworthiness. This APR will vary with the market based on the U.S. Prime Rate. Your monthly payment for the 0% options will be determined by creditworthiness. **All financing is subject to credit approval. Your terms may vary. Payment options through Hearth are provided by our lending partners. For example: a \$7,500 purchase could cost \$237/month for 36 months based on an 8.5% APR. Offers are based on creditworthiness.

P I C T U R E S

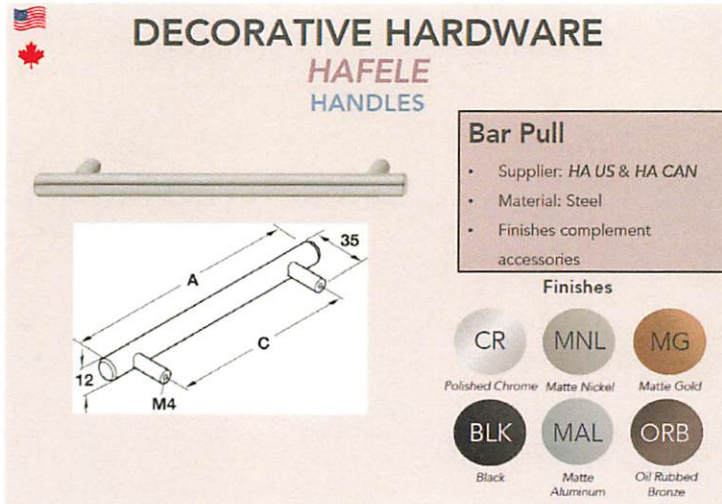

Bar Pull.png

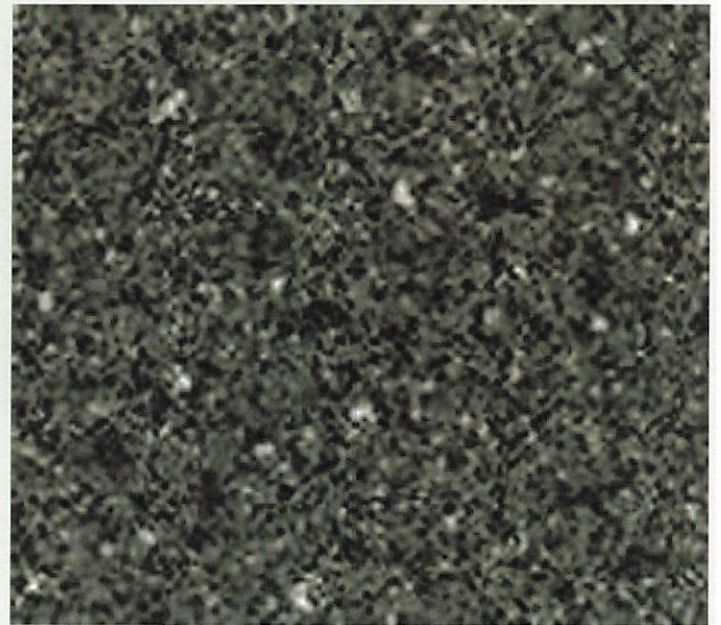

Magnified Image

Ebony Star Countertop.png

TFL COLOR PALETTE



TFL COLOR PALETTE.png

DOCUMENTS

	Heather Shelton Grandview Designs 3-17-25.pdf
---	---

TERMS AND CONDITIONS

Warranty Information:

**Floor Coating Systems: Tailored Closet Premier Garage ("TCPG") represents and warrants that

(i) the labor, and

(ii) the materials manufactured by or for TCPG used in the installation of your floor coating system is to be free from defects for as long as you own the property. This warranty is nontransferrable and applies only to the original buyer. Warrantable defects include staining from oil, transmission fluid or coolant, and peeling / delaminating.

Cabinetry/Closet Systems: TCPG represents and warrants that

(i) the labor, and (ii) the materials manufactured by or for TCPG used in the installation of your shelving/cabinet system(s) will be free from defects for as long as you own the property. This

warranty is non-transferrable and applies only to the original buyer. The above warranties exclude the following:

- Any exterior Floor Coatings, such as the apron of the garage floor that extends beyond the garage door, or coating of vertical surfaces or wood surfaces.
 - Damage caused by improper maintenance or repair, abuse, misuse, fire, water, acts of nature or other events beyond TLPG's control including, but not limited to, holes cut or drilled into Tailored Living products, and damage caused by removal or improperly maintaining the floors and/or cabinetry.
 - Damage to shelving/cabinetry caused by water or other liquids, i.e., spillage, rain, flood, etc.
 - Attempted repair or removal of TCPG products by anyone other than TCPG or its authorized dealers.
 - Damage, including dulling of the finish, due to improper cleaning methods.
 - Products that are not manufactured by or for TCPG for sale to & installation by its authorized dealers.
 - Products that have not been installed by TCPG or its authorized dealers.
 - Products that have not been paid for in full by buyer.
 - Floor Coating damage caused by a hydrostatic water problem, moisture vapor permeating the concrete slab, or exposure to battery acid or other highly corrosive chemicals.
-
- Floor Coating delamination caused by improper substrate condition, or an internal failure of the substrate.
 - Cracks in the substrate prior to or occurring after the installation of the Floor Coating system that appear from normal ground shift and expansion / contraction of the substrate, including cracking or bulging of joint fillers.
 - Scratching of the Floor Coating due to dragging or sliding heavy or sharp items across the floor coatings.
 - Floor Coating staining from tires ("plasticizer migration")
 - Rust stains appearing above, within, or below the Floor Coating.

Proof of purchase is required when making a warranty claim. All warranty claims must be in writing. To make a warranty claim, contact TCPG. TCPG will determine in its sole and absolute discretion, whether:(a) the floors and/or shelving/cabinets have been properly maintained, and (b) the warranties granted herein are applicable and not otherwise subject to the exclusions hereunder. If a claim is determined to be subject to the warranties hereunder, then TCPG will repair or replace the items subject to the claim at TLPG's expense. A claim hereunder will be your sole and exclusive

remedy. This warranty is non-transferable and applies only to the original buyer. This warranty may not be assigned or transferred.

EXCLUDING THE ABOVE, TCPG DISCLAIMS ALL EXPRESS AND IMPLIED WARRANTIES INCLUDING, BUT NOT LIMITED TO, WARRANTIES OF MERCHANTABILITY, FITNESS FOR A PARTICULAR PURPOSE, AND TRADE USAGE. FURTHERMORE, TCPG SHALL NOT BE LIABLE FOR ANY CONSEQUENTIAL, INDIRECT, INCIDENTAL, SPECIAL, PUNITIVE, OR EXEMPLARY DAMAGES (INCLUDING, BUT NOT LIMITED TO, DAMAGE TO PERSONAL PROPERTY, LOSS OF TIME, LEGAL SERVICES, OR TRAVEL) WHETHER OR NOT ADVISED OF THE POSSIBILITY OF THE SAME AND WHETHER OR NOT BASED IN WARRANTY, CONTRACT, INDEMNITY, TORT (INCLUDING, BUT NOT LIMITED TO, NEGLIGENCE), OR ANY OTHER THEORY OF LAW OR EQUITY.

Click [here](#) if you no longer wish to receive notifications or related information about this proposal.

PURCHASING DEPARTMENT
WASHINGTON COUNTY BOARD OF EDUCATION

PURCHASE ORDER

Purchase Order **No 4836**
 Date Issued **03-18-25**
 Appropriation No. **72620336-016**
 Dept. **Maintenance Repairs Equip.**
 School **DCHS**

TO **Ferguson Enterprises**

Deliver to **Maintenance Dept**

Address

Via

Articles on this order must be charged to account of

NOTICE TO VENDOR

1. Purchase order **MUST** bear two signatures in order to be valid.
2. Purchase order number **MUST** appear on all invoices submitted for payment.
3. Mail **TWO** copies of your invoice promptly to:

Washington County Board of Education
 405 West College Street
 Jonesborough, TN 37659
 Telephone (423) 753-1105

ARTICLES OR SERVICES (Unless otherwise stated all prices F.O.B. Destination)	CODE	QUANTITY & UNIT	UNIT PRICE	TOTAL
Water Heater Assembly				
* Emergency Purchase *	plus	SEH		
GRAND TOTAL - INCLUDING ALL ATTACHED PAGES				\$12,618.24

SUBJECT TO THE FOLLOWING CONDITIONS

1. All packages, cartons or other containers must be plainly marked with the purchase order number.
2. The right is reserved to purchase in the open market and to charge the difference to the Vendor in the event that deliveries are not made at the time specified in the bid and on this order.
3. Whenever a delivery is rejected, the Vendor shall be notified and be given the reason for the rejection. All rejected deliveries shall be held at the Vendor's risk and he shall bear the expense of removal.
4. Acceptance of this order includes acceptance of all terms, prices, delivery, instructions, specifications and conditions stated.
5. The county is not liable for Federal excise tax or state sales tax.
6. Each shipment and/or each purchase order should be covered by separate invoice.

IMPORTANT: INVOICES AND PACKAGES MUST BEAR PURCHASE ORDER NUMBER

VENDOR'S COPY

There is an otherwise unincumbered balance to the credit of the proper appropriation, allotment or fund to meet the expenditure covered by this purchase.

Authorized Signature

APPROVED:

Purchasing Agent

PURCHASING DEPARTMENT
WASHINGTON COUNTY BOARD OF EDUCATION
FEDERAL PROJECTS FUND
PURCHASE ORDER

Purchase Order **35832**
 Date Issued **3/25/25**
 Appropriation No. **142E-72210-399-95**
 Dept. **Academics**
 School **systemwide**

TO
TNTP INC
500 7th Ave 8th Floor
New York, NY 10018

Deliver to **Washington Co Schools**
Address **405 West College Street**
Via **Jonesborough, TN 37659**

NOTICE TO VENDOR
 1. Purchase order number **MUST** appear on all invoices submitted for payment.
 2. Mail **TWO** copies of your invoice promptly to:
 Washington County Board of Education
 405 West College Street
 Jonesborough, Tennessee 37659
 Telephone (423) 753-1105

on or before

Articles on this order must be charged to account of

ITEM NO.	ARTICLES OR SERVICES	CODE	QUANTITY & UNIT	UNIT PRICE	TOTAL
	(Unless otherwise stated all prices F.O.B. Destination)				
	Invoice # CINV25038652 EIA Curriculum Implementation Support HQIM Literacy Implementation Grant (LIM) Year 4 (2425) 3rd Installment Contract # CC21090266				\$18,200
	GRAND TOTAL - INCLUDING ALL ATTACHED PAGES				18,200

SUBJECT TO THE FOLLOWING CONDITIONS

- All packages, cartons or other containers must be plainly marked with the purchase order number.
- The right is reserved to purchase in the open market and to charge the difference to the Vendor in the event that deliveries are not made at the time specified in the bid and on this order.
- Whenever a delivery is rejected, the Vendor shall be notified and be given the reason for the rejection. All rejected deliveries shall be held at the Vendor's risk and he shall bear the expense of removal.
- No changes in or cancellations of this purchase order shall be recognized by the Vendor unless authorized by special form issued by the Purchasing Agent.
- Acceptance of this order includes acceptance of all terms, prices, delivery, instructions, specifications and conditions stated.
- The county is not liable for Federal excise tax or state sales tax.
- Each shipment and/or each purchase order should be covered by separate invoice.

IMPORTANT: INVOICES AND PACKAGES MUST BEAR PURCHASE ORDER NUMBER

VENDOR'S COPY	There is an otherwise unincumbered balance to the credit of the proper appropriation, allotment or fund to meet the expenditure covered by this purchase.	APPROVED:
	Authorized Signature	Purchasing Agent

TNTP, Inc
 500 7th Avenue, 8th Floor
 New York, NY 10018
 +1 (718) 2332800
 FEIN/EIN: 13-3850158



INVOICE

Date	Invoice Number
03/20/2025	CINV25038652
Payment Terms	Due Date
Net 30	04/19/2025
Contract Number	
CC21090266	

Bill To:
Washington County Schools 405 West College Street Jonesborough, TN 37659 United States of America

Remit To:
TNTP, Inc PO Box 412809 Boston, MA 02241-2809 United States of America +1 (718) 2332800

Purchase Order Number	Customer ID
	CUST000860

Item Description	Amount
ELA curriculum implementation support provided as part of a TDOE-funded literacy implementation network	\$18,200.00

PURCHASE CONTROL STAMP
 WASHINGTON COUNTY BOARD OF EDUCATION

Received By: C. Hayes Date: 3-25-25

Approved For Payment By: C. Hayes 3-25-25

Date Approved: 3-25-25

Fund Charged: 142E-72210-399951

Total	\$18,200.00
Less Withholding	\$0.00
Total Invoice Amount	\$18,200.00

TNTP prefers payment via ACH. Our ACH payment information is:

Account Name: The New Teachers Project Inc.
Bank Name: Bank of America
Bank Account Number: 483043601627
Bank Routing Number: 021000322
Memo/reference: Please use Invoice ID

Or, if paying by check, please make checks payable to "TNTP"
 TNTP cannot accept payment via credit card

Reviewed and certified by Lin Johnson, Chief Strategic Growth and Finance Officer, TNTP:

CodeHS & Washington County Schools Computer Science Proposal

January 30, 2025

Summary

This proposal outlines pricing options for Washington County Schools to partner with CodeHS on their computer science implementation starting in the 2025-2026 school year.

By partnering with CodeHS, Washington County Schools can implement a comprehensive computer science program. We can help provide access to a wide-variety of interdisciplinary and CS focused curriculum that meets TN state standards. We can also collaborate to ensure students across the district have access to relevant, engaging, and flexible CS pathways.

In addition to the curriculum we provide, CodeHS's tools and platform can be used to empower teachers no matter their CS experience. We will also support teachers through dedicated and ongoing support, online professional development workshops, and continued learning opportunities.

CodeHS was founded in 2012 and has supported over 4.5 million students in learning computer science. CodeHS has extensive experience working in the state of TN to help implement computer science programs in schools.

Licenses/Services Overview

District Pro Teacher License: This license includes access to all Pro and district features for a single teacher, as well as all gradebook, progress tracking, lessons, customization, and district administrator features.

Virtual PD Workshop: CodeHS will run virtual workshop sessions, covering tools, methods, and curriculum. Virtual sessions are led on zoom by the CodeHS Professional Development team. Teachers are introduced to the CodeHS platform, how to run their computer science class, and how to use the curriculum. These workshops are customized to the district and approved by district administrators in advance. Virtual PD can be half day, 1 day or two days.

PD Membership: Membership for teachers that include access to exclusive PD sessions throughout the year, a library of over 190 on-demand PD sessions, access to all mini-PD courses, access to CodeHS teacher microcredentials.

School Setup Fee: Fee to set up a school within the CodeHS system.

CodeHS Package Options

Option 1 - (1-year term):

- 5 Pro Teacher District Licenses across 2 sites
- 1 Half Day Virtual PD Workshop
- 5 Teacher PD Memberships

Items	Start Date	End Date	Quantity	List Price	Discount	Sales Price	Total Price
Pro Teacher License HS (District)	7/1/2025	6/30/2026	5	\$3,850	6%	\$3,600	\$18,000
Half Day Virtual PD Workshop	7/1/2025	6/30/2026	1	\$2,500	0%	\$2,500	\$2,500
Teacher PD Membership	7/1/2025	6/30/2026	5	\$400	5%	\$380	\$1,900
School Setup Fee - Waived	7/1/2025	6/30/2026	2	\$125	100%	\$0	\$0
Total Price (2025-2026 School Year)							\$22,400

Total Contract Price	\$22,400
-----------------------------	-----------------

Option 2 - (3-year term, paid annually):

- 5 Pro Teacher District Licenses across 2 sites
- 1 Half Day Virtual PD Workshop
- 5 Teacher PD Memberships

Items	Start Date	End Date	Quantity	List Price	Discount	Sales Price	Total Price
Pro Teacher License HS (District)	7/1/2025	6/30/2026	5	\$3,850	14%	\$3,312	\$16,560
Half Day Virtual PD Workshop	7/1/2025	6/30/2026	1	\$2,500	0%	\$2,500	\$2,500
Teacher PD Membership	7/1/2025	6/30/2026	5	\$400	5%	\$380	\$1,900
School Setup Fee - Waived	7/1/2025	6/30/2026	2	\$125	100%	\$0	\$0
Total Price (2025-2026 School Year)							\$20,960
Pro Teacher License HS (District)	7/1/2026	6/30/2027	5	\$3,850	14%	\$3,312	\$16,560
Half Day Virtual PD Workshop	7/1/2026	6/30/2027	1	\$2,500	0%	\$2,500	\$2,500
Teacher PD Membership	7/1/2026	6/30/2027	5	\$400	5%	\$380	\$1,900
School Setup Fee - Waived	7/1/2026	6/30/2027	2	\$125	100%	\$0	\$0
Total Price (2026-2027 School Year)							\$20,960
Pro Teacher License HS (District)	7/1/2027	6/30/2028	5	\$3,850	14%	\$3,312	\$16,560
Half Day Virtual PD Workshop	7/1/2027	6/30/2028	1	\$2,500	0%	\$2,500	\$2,500
Teacher PD Membership	7/1/2027	6/30/2028	5	\$400	5%	\$380	\$1,900
School Setup Fee - Waived	7/1/2027	6/30/2028	2	\$125	100%	\$0	\$0
Total Price (2027-2028 School Year)							\$20,960

Total Contract Price	\$62,880
Annual Savings	\$3,040
Total Contract Savings	\$9,120

Color Sheet-fed Digital Press

RICOH Pro C7500

RICOH
imagine. change.



Do more with a 5th Color digital press that delivers true production level performance.

Unlock a full spectrum of opportunity.

Powerfully robust. Creatively engineered. The RICOH Pro C7500 5th Color Station Digital Press comes to market with enhanced performance, upgraded media handling and built-in automation — all so you can take on more work and meet the growing desire for creative communication that engages audiences and drives actions.

Tackle premium jobs with cost certainty. Streamline workflows. And turn information into inspiration. Do it all with our newest digital press.

5th Color toners include gold, silver, neon pink, neon yellow, clear, white and invisible red

Product highlights

- 5th Color capabilities*
- Print speeds up to 95 ppm**
- Maximum paper capacity of 16,200 sheets
- Media support from 40 to 470 gsm
- Oversized options up to 49.6" long
- Auto duplexing up to 13" × 38"
- Professional inline finishing
- 21-inch Smart Operation Panel
- Auto color calibration
- Precise registration
- 2400 × 4800 dpi resolution



* 5th Color activation plans vary by sales channels. Please consult your Ricoh sales representative regarding activation method.
** Standard speed is 85 pages per minute; with the optional Productivity Upgrade Kit, speed increases to 95 pages per minute.

Premium outcomes. Infinite possibilities.

Differentiate yourself with the power of Ricoh's 5th Color Station. Achieve vivid colors comparable to offset, from brighter oranges to deeper purples and luscious greens. Elevate applications with premium gold and silver. Use neon pink or neon yellow for high-impact messaging. Open the door to a new set of customers with invisible red for affordable security on certificates and tickets. Apply white as a base layer to deliver incredible graphics on colored and transparent media. Add clear to photos and logos for a slick look and explore unique patterns for luxury effects.



CMYK only

5th Color Neon Pink toner
blended with CMYK



Blend in to stand out

Print structure overview



6 unique colors created



Blend guide

C55		100
C70 M10		100
Y100		100
M30 Y100		100
Y32		50
		100

More media. More color. More possibilities.

Choose either the new Fiery® N-50A or N-70A Color Controller Digital Front End based on Fiery and Ricoh technology to get more jobs done in a day. Process larger and more complex files faster than ever.

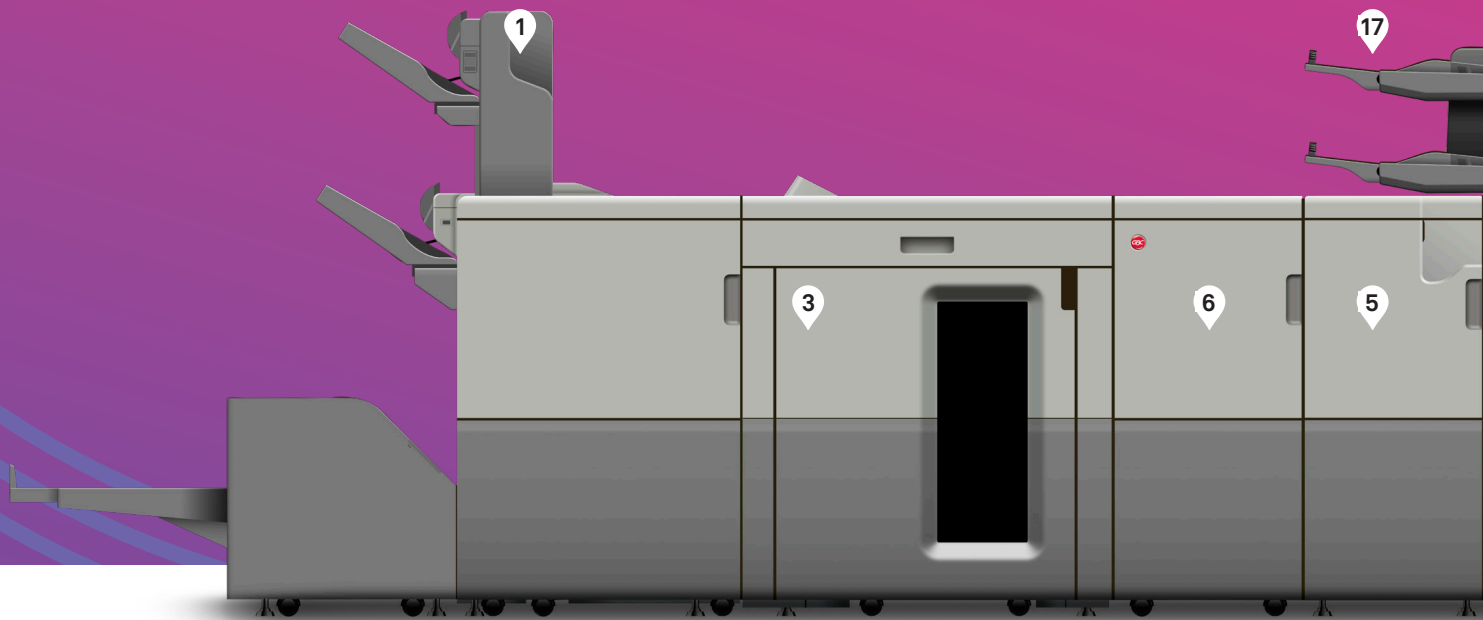

1 3,500-Sheet Booklet & Staple Finisher (SR5120)*

Saddle-stitch booklets up to 30 sheets and staple up to 100 sheets quickly at sizes up to 13" × 19.2".

2 Plockmatic Booklet Maker PBM5035/5035s*°

Create booklets up to 50 sheets of paper inline or offline with three-sided trimming and square fold. Supports up to 350 gsm coated or uncoated paper stocks.

3 High-Capacity Stacker (SK5040)*

A 5,000 sheet stacker with a rollaway cart quickly moves large output volumes to offline binding, or packing and shipping.

4 Perfect Binder (GB5010)*°

Glue and bind up to 200 sheets with three-edge trimming, including covers up to 300 gsm.

5 Six-Position Multi-Folding Unit (FD5030)*

Execute up to six types of folds to give your customers a wider range of finished documents.

6 GBC StreamPunch™ Plus & StreamWire*

Achieve professional quality with inline punching for media up to 300 gsm. Automate inline binding systems for twin-loop wire-bound booklets.

7 Full-Color Touch Screen Control Panel

Transition between jobs effortlessly via fingertip control and animated guides from the post-mounted 21-inch Smart Operation Panel.

8 Status Light Pole

Know the moment maintenance is required, even if you're away from the device.

9 VCSEL & Active Toner Density Control°

Create output with brilliant colors and smooth gradations for sharper text and more precise reproductions.

10 Oversize & Heavy Media Support°

Handle more types of media, including up to 13" × 19" standard paper sizes, a 38" oversize option, and heavy media up to 173 lb. cover (470 gsm), and keep more jobs in-house.

*Optional

°Not shown



11 Media Identification Unit*

Eliminate guesswork during print production prep work and easily associate media with the closest available match in your media library.

12 Paper Trays (Standard)

With a total paper capacity of 4,400 sheets, you can print with fewer reloads. Increase capacity to 16,200 sheets with optional paper sources.

13 Active Tray Indicators

Find out which tray is currently being fed into the printer so you can refill other paper sources without interrupting the run.

14 Vacuum Feed Large Capacity Input Tray Type S14*

Ensure paper feeds run continuously with a three-belt air-blasting tool that handles coated papers up to 173 lb. cover (470 gsm).

15 Bridge Unit (BU5010)*°

Extend print runs and minimize interruptions by bridging three 4,400 sheet trays.

16 Vacuum Feed LCIT (RT5150)*

4,400 sheet Vacuum Feed LCIT can handle paper sizes up to 13" x 19.2" and paper weights up to 173 lb. cover (470 gsm).

17 Cover Interposer Tray (CI5040)*

Feed pre-printed sheets for fast production of front and back covers.

18 Plockmatic High Capacity Interposer*°

Use for automatically inserting pre-printed offset prints, front covers, back covers or tabs into your finishing workflow.

19 Multi Bypass Tray (BY5020)*°

Feed up to 500 sheets of specialty stocks, including sizes up to 49.6" and expand what you can offer customers.

Expand your offerings to **stay current** and relevant to client needs

Engineered for easy operation.

Offer the premium products your customers demand — on time and on budget. The RICOH Pro C7500 is a high-performance digital press designed to power productivity. An intuitive 21-inch Smart Operation Panel provides a wider field of vision and the ability to remotely monitor the system from a smartphone or tablet. Specialty toners can be swapped in under 15 minutes, minimizing downtime. Built-in automation, such as color calibration, front-to-back registration and auto duplexing up to 13" × 38" keeps work flowing smoothly for operators of all skill levels.

Sophistication meets simplicity.

Informed by real-world needs, the RICOH Pro C7500 is packed with innovation that removes complexities. Powerful controllers manage mixed media jobs with ease and make it possible to create highly-targeted mailers, catalogs, welcome kits and more with printing that aligns variable data with variable imagery. Add automated workflow solutions to eliminate manual steps and choose from an array of industry-leading finishing options to fold, cut, crease and bind jobs, all inline.



Visit takealookatricohproduction.com/5thcolor to see more applications and watch video tutorials.

More media. More opportunities.

Enhancements to the Media Identification Unit and Media Library enable everyone in your organization to achieve best-in-class, repeatable results. Confidently run specialty stocks, synthetics, oversized sheets and magnetic media. Go thin or heavy with paper weights from 40 to 470 gsm. From instruction pamphlets and decorative liners to short-run packaging and unique direct mailers, the RICOH Pro C7500 gives you more ways to produce robust applications and meet even the tightest deadlines.

Manage costs. Increase profits.

Empower your sales reps with the technology they need to accurately price 5th Color jobs. Calculate specialty toner costs using the Fiery® Smart Estimator Tool on the RICOH Pro C7500 — accessible via the Fiery Command WorkStation. Formulate an estimate based on your per bottle cost, export the information and convert it to a file that can easily be integrated into your MIS system. This ensures margins are met and profitability goals are reached. Enjoy greater cost certainty and a more accurate estimate of the overall job.

Exclusive resources. Dynamic services.

With Ricoh by your side, success starts from day one. Gain 24/7 access to turnkey marketing materials, print samples, how-to guides and a library of video tutorials. Tap into Ricoh's Professional Services team for targeted assistance. Our portfolio of right-sized solutions helps fast-track your goals, from web-to-print and color management to marketing automation, package design, advanced finishing and so much more. We deliver everything you need to educate operators and maximize sales.

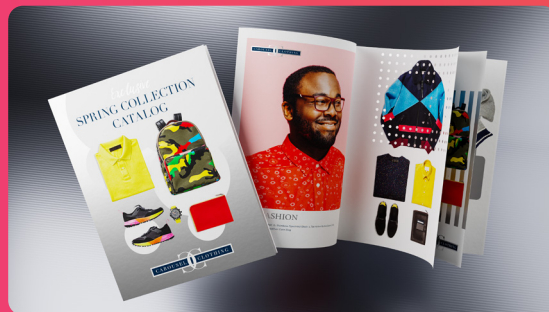

Speak to your dedicated Ricoh specialist to request samples and schedule a demo.

RICOH Pro C7500

SYSTEM SPECIFICATIONS

Hardware Specifications

Process	4-drum (standard) / 5-drum (optional) dry electrostatic transfer system with internal transfer belt
Fusing Engine Speed	Oil-less, belt fusing method 85 ppm (standard) 95 ppm (with the optional Productivity Upgrade Kit)
Max. Monthly Volume	240K
Duty Cycle	1,500K 1,700K (with the optional Productivity Upgrade Kit)
Resolution	2400 x 4800 dpi VCSEL
Warm-Up Time	Less than 300 sec.
Limitless Paper Supply Paper Size	Supply Supported 13" x 19.2" - 13" x 49.6" (when using Oversize Tray option) 12.7" x 18.9" - 12.7" x 49.4" (when using the Oversize Tray option)
Maximum Printable Area	Tray 1: 52 - 300 gsm Tray 2: 52 - 256 gsm Trays 3 - 8: 40 - 470 gsm Optional Vacuum Feed LCIT RT5150 Optional Bypass Tray 52 - 216 gsm
Paper Weight	Uncoated Paper, Coated Paper (gloss and matte), Recycled Paper, Preprinted, Letterhead, Pre-punched, Tab Stock, Textured Paper, Label Paper, Carbonless Paper
Paper Type	Tray 1: 1,000 sheets x 2 (Tandem) Tray 2: 500 sheets Tray 3 - 8: 2,200 sheets Optional Bypass Tray: 500 sheets Optional Banner Sheet Tray: 800 sheets Optional Extension Banner Sheet Tray: 500 sheets
Paper Capacity	220 - 240 V, 16 A x 2, 50/60 Hz
Power Source	Less than 5,000 W
Max. Power Consumption	Less than 5,000 W
Typical Electricity Consumption (TEC)*	14,400,000 A4 pages or 5 years

*Typical Electricity Consumption by ENERGY STAR® program

ENERGY STAR	Certified
EPEAT	Silver
Dimensions (W x D x H)	52" x 36" x 74" (including status pole)
Weight	Less than 1,235 lbs.

Printer Controllers

Fiery Controller N-70A/N-50A

Fiery System Version	Fiery FS500 Pro
Configuration	External
Memory	8GB RAM (4GB x 2)
CPU	i5-8500 Processor
HDD	SSD Boot Drive for OS and Fiery software + 1TB HDD
Operating System	Windows 10 IoT Enterprise 2019 LTSB

Accessories

Vacuum Feed Large Capacity Tray (LCIT RT5150)

(Max. 3 units per system)	
Paper Capacity	4,400 sheets (2,200 sheets x 2 Trays)
Paper Size	3.94" x 5.5" - 13" x 19.2"
Paper Weight	Trays 3 - 4: 40 - 470 gsm Trays 5 - 8: 40 - 400 gsm
Dimensions (W x D x H)	41.5" x 28.7" x 39.4"
Weight	507 lbs.

Vacuum Feed Oversize Tray Type S9

Paper Capacity	730 sheets
Paper Size	8.27" x 16.54" - 13" x 27.5"
Paper Weight	52 - 400 gsm Width of LCIT RT5120 will extend to 50.8"

Extension Vacuum Feed Banner Sheet Tray Type S14

Paper Capacity	500 sheets
Paper Size	8.27" x 16.54" - 13" x 38"
Paper Weight	52.3 - 470 gsm (16.54" - 19.2") 52.3 - 300 gsm (19.3" - 27.5") 63.1 - 300 gsm (27.6" - 38")

Multi Bypass Tray Unit (BY5020)

Paper Capacity	500 sheets
Paper Size	3.94" x 5.5" - 13" x 19.2" Maximum paper size extends up to 13" x 27.5" by adding the optional Multi Bypass Sheet Tray Type S9
Paper Weight	52 - 216 gsm

Cover Interposer Tray (CI5040)

Paper Capacity	400 sheets (200 sheets x 2 Trays)
Paper Size	5.5" x 8.5" - 13" x 19.2"
Paper Weight	52 - 350 gsm
Air Assist	Supported
Double Feed Detection	Optional
Dimensions (W x D x H)	13" x 28.7" x 50.8"
Weight	110 lbs.

4,500-Sheet Finisher with 100-Sheet Stapler (SR5110)

Paper Capacity	Lower Shift Tray: 3,500 sheets Upper Shift Tray: 1,000 sheets
Paper Weight	Lower Shift Tray: 52 - 470 gsm Upper Shift Tray: 52 - 350 gsm
Punch	Optional 2/3 hole
Dimensions (W x D x H)	39.2" x 28.7" x 55.7"
Weight	298 lbs.

3,500-Sheet Booklet Finisher with 100-Sheet Stapler (SR5120)

Paper Capacity	Lower Shift Tray: 2,500 sheets Upper Shift Tray: 1,000 sheets
Paper Weight	Lower Shift Tray: 52 - 470 gsm Upper Shift Tray: 52 - 350 gsm
Punch	Optional 2/3 hole
Saddle Stitch Staple	Supported
Paper Size	7.2" x 10.2" - 13" x 19.2"
Paper Weight	52 - 350 gsm
Dimensions (W x D x H)	52 - 80 gsm up to 30 sheets/120 pages 39.2" x 28.7" x 55.7"
Weight	353 lbs.

Booklet Trimmer (TR5050)

Trimming Type	One Side Edge
Trimming Capacity	Up to 30 sheets/120 pages
Paper Size	7.2" x 10.2" - 13" x 19.2"
Stack Capacity	Up to 60 sets
Limitless Stack	Supported
Dimensions (W x D x H)	43.9" x 23.3" x 21.9"
Weight	166 lbs.

High Capacity Stacker (SK5040)

Paper Capacity	5,000 sheets; Proof tray: Additional 250 sheets
Paper Weight	52 - 470 gsm
Rollaway Cart	Standard and Optional additional carts available
Dimensions (W x D x H)	35.4" x 26.7" x 39.8"
Weight	Stacker: 284 lbs.; Rollaway cart: 33 lbs.

FD5030 Multi-Folding Unit

Folding Type	Z-Fold, Half-Fold/Print inside, Half-Fold/Print outside, Letter Fold-in/Print inside, Letter Fold-in/Print outside, Letter Fold-out
Single Sheet Mode	Half-Fold/Print inside, Half-Fold/Print outside, Letter Fold-in/Print inside, Letter Fold-in/Print outside, Letter Fold-out
Multiple Sheets Mode	Half-Fold/Print inside, Half-Fold/Print outside, Letter Fold-in/Print inside, Letter Fold-in/Print outside, Letter Fold-out
Paper Size Single Sheet	Z folding: 8.5" x 11" - 12" x 18"; Half folding: 8.5" x 11" - 13" x 19.2"; Letter folding: 8.5" x 11" - 12" x 18"; Double Parallel folding: 8.5" x 11" - 12" x 18"; Gate folding: 8.5" x 11" - 12" x 18"; Half folding: 8.5" x 11" - 13" x 19.2"; Letter Fold-in: 8.5" x 11" - 12" x 18"; Letter Fold-out: 8.5" x 11" - 8.5" x 14"
Multiple Sheets Mode	Half folding: 8.5" x 11" - 13" x 19.2"; Letter Fold-in: 8.5" x 11" - 12" x 18"; Letter Fold-out: 8.5" x 11" - 8.5" x 14"
Paper Weight	64 - 105 gsm
Single Sheet Mode	64 - 80 gsm
Multiple Sheets Mode	18.5" x 28.7" x 39.4"
Dimensions (W x D x H)	203 lbs.
Weight	

Plockmatic High Capacity Interposer (HCI3500)

Paper Capacity	3,500 sheets (1,750 sheets x 2 Trays)
Paper Weight	65 - 350 gsm
Paper Size	4.72" x 8.27" - 13" x 26"
Dimensions (W x D x H)	47.2" x 28.7" x 43"
Weight	551 lbs.

Plockmatic MPS - Oversize Sheet Stacker

Paper Capacity	2,000 sheets
Paper Weight	150 - 470 gsm
Paper Size	8.5" x 11" (LEF) - 13" x 49.6"
Dimensions (W x D x H)	35.4" x 26.8" x 41.8" (width extends to max. 55")
Weight	172 lbs.

Plockmatic Booklet Maker (PBM350e)

Paper Size	8.5" x 11" - 12" x 18"
Paper Weight	64 - 300 gsm
Set Size	2 - 35 sheets - 80 gsm
Dimensions (W x D x H)	55.9" x 35.4" x 27.6"
Weight	297 lbs.
Optional	Trim Module, Book Fold Module, Cover Feeder, Rotate, Crease Trimmer

Plockmatic Booklet Maker PBM5035/5035S

Paper Size	Staple: 8.11" x 8.27" - 12.6" x 24.4" Stitch: 4.27" x 8.27" - 12.6" x 24.4"
Paper Weight	18 lb. Bond to 130 lb. Cover (dependent on paper type and quality)
Book Thickness	Min. Set: 1 sheet of 20 lb. Bond Max. Finished Book: 0.393" (approx. 200 pages 20 lb. Bond) Max. Set: 0.137" or 0.196" (approx. 35 sheets and 50 sheets of 20 lb. Bond)

GBC StreamPunch Plus

Punched Paper Sizes	5.5" x 8.5", 8.5" x 11", 8.5" x 14", 11" x 17", 12" x 18"
Punched Media	75 - 300 gsm
Weight Range	
Tab Punching	Supported
"Two-Up" Punching	Supported
Dimensions (W x D x H)	17.5" x 28.7" x 39.4"
Weight	220 lbs.

GBC StreamWire (GBC StreamPunch Plus is required)

Paper Sizes	8.5" x 11" (LEF)
Paper Weight	75 - 300 gsm
Number of Loops	8.5" x 11" (LEF) - 32 loops
StreamWire Supply	Black, White or Silver Up to 30, 50, 60, 70 or 80 Sheets
Tab Stock	Supported
Dimensions (W x D x H)	34" x 38" x 34"
Weight	500 lbs.

Additional Accessories

Multi Bypass Banner Sheet Tray Type S9, Buffer Pass Unit Type S9, Bridge Unit BU5020, Extension Output Banner Sheet Tray Type S14, SR5000 Series Output Tray for Banner Sheet Type S6, Perfect Binder GB5010, Plockmatic LC3500 XL, Plockmatic CT XL, Plockmatic SBT, RPII Interface Box Type S3

Consumables

Black Toner	67.0K prints/bottle*
Cyan Toner	67.0K prints/bottle*
Magenta Toner	67.0K prints/bottle*
Yellow Toner	67.0K prints/bottle*
Clear Toner	29.2K prints/bottle**
White Toner	19.0K prints/bottle**
Neon Yellow Toner	27.8K prints/bottle**
Neon Pink Toner	27.8K prints/bottle**
Invisible Red Toner	20.6K prints/bottle**
Silver Toner	19.0K prints/bottle**
Gold Toner	19.0K prints/bottle**
Waste Toner Bottle Yield	175K prints/bottle*

*Based on 8.75% coverage (LT)

**Based on 15% coverage (LT)

TCRU Program Supported

Workflow Solutions Supported

RICOH ProcessDirector®, RICOH TotalFlow™ Producer, RICOH TotalFlow Prep, RICOH TotalFlow Production Manager, RICOH TotalFlow BatchBuilder™, EFI DirectSmile, ePS MarketDirect StoreFront, CGS/ORIS Lynx & Evaluate Fiery® Central, Fiery Color Profiler Suite, Objectif Lune

Specifications are subject to change without notice. Contact Ricoh for a list of certified media.



www.ricoh-usa.com



EPEAT Silver rating is applicable only in the USA.

Ricoh USA, Inc., 300 Eagleview Blvd, Exton, PA 19341, 1-800-63-RICOH

©2023. Ricoh USA, Inc. All rights reserved. Ricoh® and the Ricoh logo are registered trademarks of Ricoh Company, Ltd. All other trademarks are the property of their respective owners. The content of this document, and the appearance, features and specifications of Ricoh products and services are subject to change from time to time without notice. Products are shown with optional features. While care has been taken to ensure the accuracy of this information, Ricoh makes no representation or warranty as to the accuracy, completeness or adequacy of the information contained herein, and shall not be liable for any errors or omissions in these materials. Actual results will vary depending upon use of the products and services, and the conditions and factors affecting performance. The only warranties for Ricoh products and services are as set forth in the express warranty statements accompanying them.

Section 9.1 Power Requirements & Specifications

North America	208 -240V, 50/60 Hz Single Phase NEMA Two 6-20P 20A (40A total) Dedicated Lines	2 Power Cords	12 ft. length	Customer Initials _____ Ricoh Initials _____
----------------------	--	---------------	---------------	---

- Power Filter Requirement:**
- Two Power Filters are required
 - Included with machine purchase



- Notes:**
- The Pro C7500 machines come standard with 2 (two) power plugs.
 - Total Outlets needed: Main Machine are 208-240V, all other options are 110V.
 1. Main Machine (2 plugs)
 2. Vacuum Feed LCT (1 plug each)
 3. Stacker (1 plug each)
 4. Finisher (1 plug)

Refer to the table below for specific power requirements for your configuration.

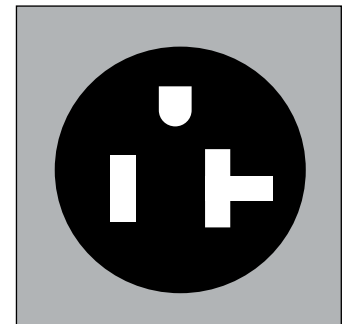

*NEMA 6-20R Receptacle
(two required)*

Warm-up Time	Less than 540 sec.@73°F (23°C), rated voltage (Warm up time can vary based on room temperature)	
Power Specification	NA	208-240V, less than 40A (20A x2), 50/60Hz
	EU/AP	220-240V, less than 40A (20A x2), 50/60Hz
Max. Power Consumption	Less than 5000W	

Accessories which require external power

Item	Unit Description	Power Specifications (NA)	Plug Type	Cord
Fiery N-50A or N-70A DFE	Print Controller / DFE	120v, 50/60Hz; 15A	NEMA 5-15	3 feet
Fiery LCD Monitor FACI Kit	FACI Connection Kit LCD Monitor or Monitor	120v, 50/60Hz: 15A	NEMA 5-15	3 feet
Ricoh SR5110	3000 Sheet Stapler/Finisher	120v, 50/60Hz: 15A	NEMA 5-15	3 feet
Ricoh SR5120	Booklet Finisher	120v, 50/60Hz: 15A	NEMA 5-15	7 feet
Ricoh TR5050	Booklet Trimmer Unit for SR5120	120v, 50/60Hz: 15A	NEMA 5-15	7 feet
Ricoh FD5020	Multi-Folding Unit	120v, 50/60Hz; 15A	NEMA 5-15	7 feet
Ricoh SK5040	High-Capacity Stacker (up to 2 per Engine)	120v, 50/60Hz; 15A	NEMA 5-15	6 feet
GBC Streampunch Plus	GBC Streampunch Plus	120v, 50/60Hz: 15A	NEMA 5-15	3 feet
GBC Streamwire	Inline Binding System w Streampunch	120v, 50/60Hz: 15A	NEMA 5-15	6 Feet
GB5010	Perfect Binder	200-240V 50/60Hz 15A	NEMA 6-15	15 feet
Plockmatic PBM 350/500	Plockmatic Production Booklet Finisher	100/110 50-60Hz	NEMA 5-15	10 feet
Ricoh Vacuum Feed LCT RT5150	Up to 3 per Engine	120v, 50/60Hz: 15A	NEMA 5-15	6 feet
Plockmatic MPS	Banner Sheet Stacker	120v, 50/60Hz: 15A	NEMA 5-15	6 feet
Plockmatic HCI3500	High Capacity Inserter Post Process	120v, 50/60Hz: 15A	NEMA 5-15	6 feet

NOTE: Not all peripheral options are listed in this chart.
For specific power requirements for your configuration, please visit the Ricoh online configurator tool at ricohconfigurator.com

Section 9.2 Environmental Requirements

1. If the machine is installed in a location where the ambient temperature is more than 86°F (30°C), do not run full color printing longer than 2 hours, and never turn the main power switch off immediately after a long print job. Leave the machine on so that the fans can expel the hot air from the machine and cool the electronic components.
2. If the installation site has air-conditioners or heaters, put the machine in a location that agrees with these conditions:
 - Where there are no sudden temperature changes from low to high, or high to low.
 - Where the machine will not be directly exposed to cool air from an air conditioner in the summer.
 - Where the machine will not be directly exposed to reflected heat from a heater in the winter.
4. Do not put the machine where it will be exposed to gases like ammonia that can cause corrosion.
5. Put the machine on a strong & level surface. The front and rear of the machine must be level $\pm 0.1''$ ($\pm 2.5\text{mm}$).
6. Never put the machine where it can be subjected to strong vibration.
7. Never connect the machine to a power source shared with other electrical devices.
8. The machine can generate an electromagnetic field which can cause interference with radio or television reception.
9. For environments which may contain pressroom chemicals, cleaners, and fumes on a constant basis, within close proximity to the Ricoh product, considerations to maintain image quality, performance, and parts longevity should be discussed before product installation. The following list may provide some guidance:
 - Ventilation specification of the location or space where the Ricoh product is installed. This would include the movement/displacement of air away from the printer.
 - Ventilation performance during production times of day as well as idle, non-production time of day. Gases and other chemicals can settle during these times and deposit a film over certain imaging components.
 - Paper should be stored in a chemical-free environment for optimal image quality and performance.
 - Consult with your Ricoh team for an on-site walk through to determine the optimal installation location.

	Specification
Target Operating Condition	73°F (23°C) @ 50% RH
Recommended Temperature Range	59°F – 77°F (15°C – 25°C)
Recommended Humidity Range	30% to 70% RH
Maximum Temperature Range	50°F – 90°F (10°C – 32°C)
Maximum Humidity Range	15% to 80% RH
Maximum Elevation	6,562 ft (2000m) above sea level
Ambient Illumination	Less than 1500 lux (no direct sunlight)
Ventilation	Air turnover rate of more than 30m ³ /hr/person
Ambient Dust	< 2.7 x 10/6 oz/yd ³ (< 0.10mg/m ³)

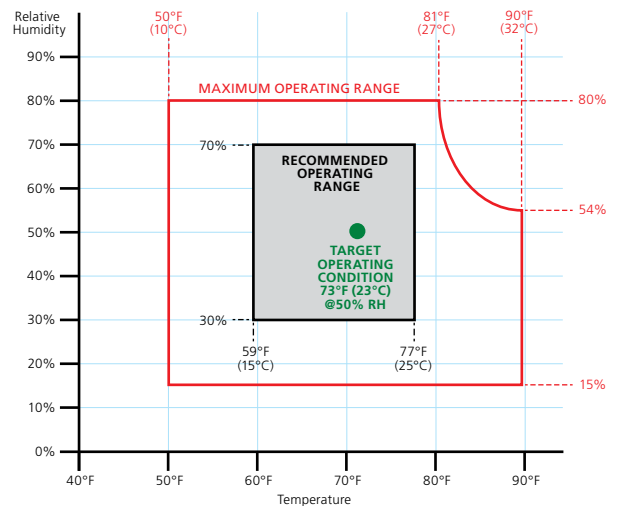

Note:
Operating outside of desired range could result in reduced performance and image quality.

Sound Power Level, Pro C7500 series	
Stand-by	Less than 72dB
Printing	Less than 79dB

Section 9.3 Weight & Clearance Requirement

Notes:

- At least 39.4" (1000mm) clearance recommended at the front, right, and left side of the machine for servicing.
- At least 31.5" (800mm) clearance is recommended behind the machine for servicing.
- No accessories shown. When installing the peripherals, at least 39.4"(1000mm) clearance is recommended on all four sides of the machine.
- The front and rear of the machine must be level $\pm 0.1"$ ($\pm 2.5\text{mm}$).

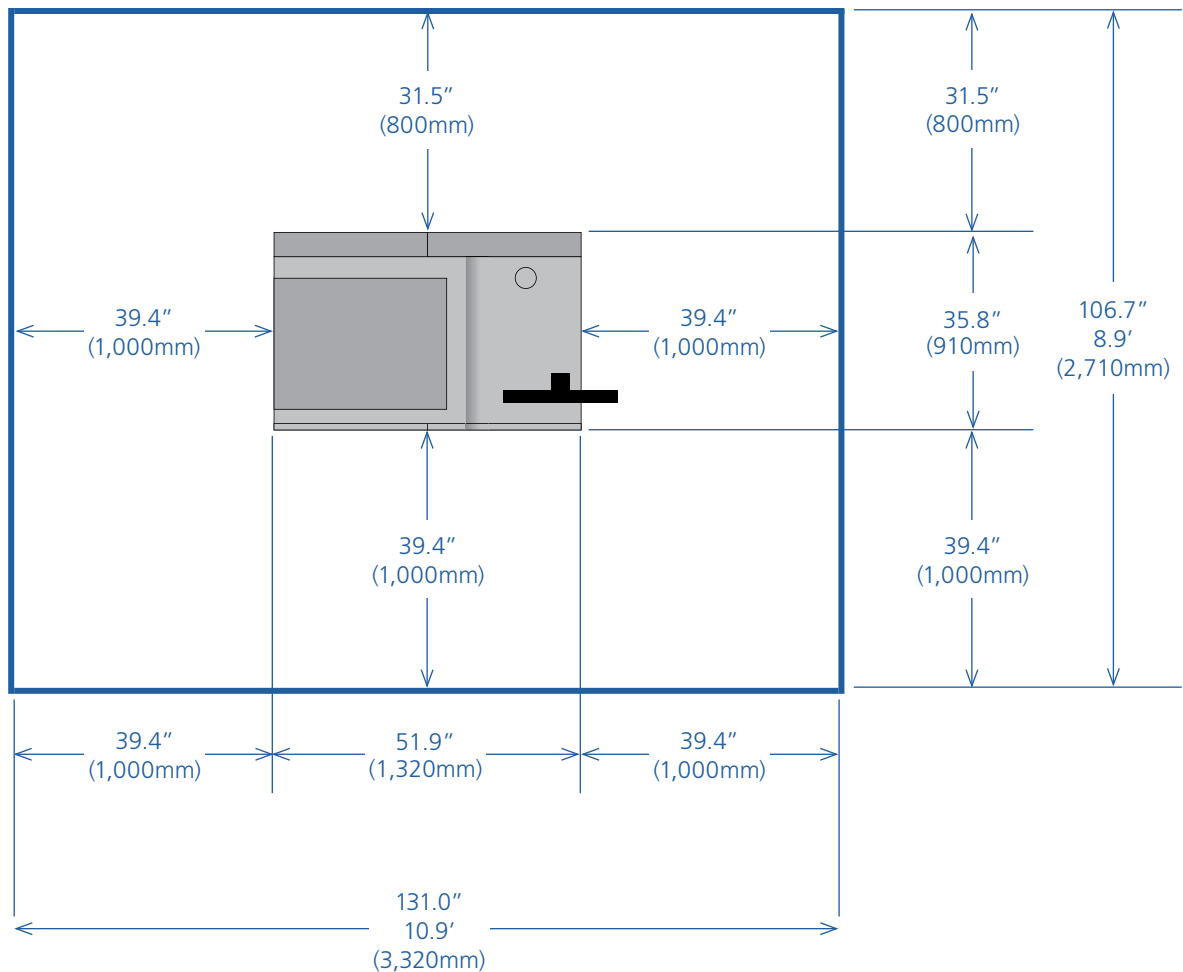

Physical Dimensions

		Specification
Dimension (W x D x H)		51.9" x 35.8" x 47.9" 1,320mm x 910mm x 1,218mm (excludes status pole and operator panel)
Weight	4-Color (CMYK) version	1,234lbs. (560kg) approx.
	5-Color (CMYK+S) version	1,279lbs. (580kg) approx.

Washington
County Schools

Production Print
Proposal

Revision 1



RJY Young

Technology Solutions That Power Your Business

March 10, 2025

PREPARED BY:

Will White

423-276-0141

will.white@rjyoung.com

Ricoh Pro C7500



Powerfully robust. Creatively engineered. Capable of printing media up to 470 GSM.

The RICOH Pro C7500 5th Color Station Capable Digital Press comes to market with enhanced performance, upgraded media handling and built-in automation. All so you can take on more work and meet the growing desire for creative communication that engages audiences and drives actions. Tackle premium jobs with cost certainty. Streamline workflows. And turn information into inspiration. Do it all with our newest digital press.

It incorporates outstanding technologies in a scalable footprint as noted below:

Proposed Configuration:

- Ricoh Pro C7500 85 Ppm Print Engine (No Scanner) Four Color Configuration
- Vacuum Feed LCIT with Multi Bypass Tray
- SR5110 Staple Finisher with 3 Hole Punch
- N-50 Fiery Controller with Impose, Compose, and Spectrophotometer
- Plockmatic 350e, Rail, Bookfold (Square Bind), Face Trim, and Cover Feeder
- TCRU Kits
- Power Filters

Ricoh Pro C7500 Financial Summary

Description	Pricing
Ricoh Pro C7500	60 Month FMV Lease: \$2,045.04 per month Color Cost Per Click: .034 Mono Cost Per Click: .0075

Included in Above Programs:

- Project Management
- Delivery
- Installation
- Continuous RJ Young Workflow Support and Training

Terms

- Service price locked in for 60 months
- Cost per Copy includes parts, labor, and toner
- Cost per Copy is up to 13x19.2", per side
- This proposal is valid until March 21, 2025
- Proposal and configuration is for budgetary purposes only. Pricing and financing terms are subject to change for any reason.

Additional Customer Support:

- Customer will receive a credit of up to \$8,500 towards color click charges for a total of 250,000. This will expire once the maximum credit has been exhausted OR if six months has lapsed from the installation date (whichever comes first). This promotion is good with a signed order no later than March 21, 2025.
- Customer will receive one free courtesy copier to be used in the classroom (or on the campus) for convenience scanning and printing. Please note that a small service charge will be applied.
- RJY will provide technical training support for 2 days per semester over the lease term. This is to be utilized for student worker training as discussed with Chris Tipton. This is above and beyond the typically continuous workflow support given to customers.
- RJY will offer support to one key operator for Fiery Certification (Professional Level)

Customer Expectations

- RJ Young will require access to the customer's business for a walkthrough and site survey. The customer will have all power requirements in place and installed prior (or day of) installation.
- For optimum results, the customer will install and operate the product within the required environmental expectations.





RJYoung

Technology Solutions That Power Your Business

WE MAKE IT RIGHT GUARANTEE

Careful attention to customer satisfaction is the reason we've been in business since 1955.

“Our policy is very simple. If you are not happy with our equipment, service, supplies, billing - anything - let us know and we'll make it right, right away.”

Chip Crunk
President & CEO





RJJYoung

Technology Solutions That Power Your Business

Frontline Education Renewal Notice

Attn: Washington County School District

Thank you for your continued partnership with Frontline Education. We remain focused on providing you with industry-leading solutions and technology for K-12. As part of the ongoing investment in your solutions, our Learning Center continues to be enhanced to provide access to articles with answers to routine questions 24/7. This includes the ability to create a support request directly from the Learning Center. Additionally, we have enhanced our Learning Center with Frontline Support Communities for many of our solutions, empowering you to collaborate with your peers, our experts and to share best practices with K-12 partners across your region and the country.

Below you will find information about the renewal of your subscription(s) that renew on 7/01/2025. Once you have reviewed the pricing for your upcoming subscription you can either:

- Use this [link](#) to confirm the renewal of your subscriptions, or
- If you have questions please reach out to your Client Success Manager

Description	Start Date	End Date	Qty	Rate	Amount
Human Capital Management - Recruiting & Hiring Bundle	7/01/2025	6/30/2026	1	\$30,746.71	\$30,746.71
Absence & Substitute Management, unlimited usage for internal employees	7/01/2025	6/30/2026	1	\$31,605.37	\$31,605.37
Total					\$62,352.08

Please use this [link](#) to indicate that you intend to renew your subscriptions and request your invoice if needed.

Need assistance? You can reach us by calling Daniel Lopez at (484) 328-4049 or by emailing us at renewals@frontlineed.com.

Robert Hawkins



Quote ID Q-197750
02/25/2025

Robert Hawkins
Vice President, Client Success



WASHINGTON COUNTY SCHOOLS

INSPIRE * STRIVE * THRIVE

Mr. Jerry S. Boyd
Superintendent

405 W. College St.
Jonesborough, TN 37659
Phone (423) 753-1100

BID QUOTATION SHEET

Gym Floor Refinishing

Bid Opening: **Tuesday, March 18, 2025, at 2:00 PM EST**

The undersigned bidder acknowledges having read and understood the **Invitation to Bid** and specifications and agrees to comply with all stated terms and conditions. Upon award, the bidder will complete the refinishing of the gym flooring at **David Crockett High School** and **Lamar Elementary School** as outlined.

Bid Details

Lamar Elementary:

1. Repair/replacement of all damaged areas
2. Sand, seal & finish approximately 8,400 sq. ft.
3. Paint (1) Main Basketball Game Lines
4. Paint (1) Main Volleyball Game Lines
5. Paint (2) "Lamar" end-court lettering
6. Painted border
7. Paint center court logo
8. Paint (3) Four Square courts
9. Paint (2) 1-26 one-color numbers
10. Paint (2) A-Z one-color letters

David Crockett High School:

1. Sand, seal & finish approximately 8,200 sq. ft.
2. Paint (1) Main Basketball Game Lines
3. Paint (1) Main Volleyball Game Lines
4. Paint (2) "David Crockett" end-court lettering
5. Paint free-throw lane
6. Painted border
7. Paint center court logo
8. Stain areas outside three-point lines
9. Mark corners of side volleyball courts

TOTAL BID AMOUNT: \$ 55,300.00

Board of Directors

Eric Barnes
Annette Buchanan
Keith Ervin

Chad Fleenor
David Hammond
Gregg Huddleston

Mike Masters
Whitney Riddle
Vince Walters



WASHINGTON
COUNTY SCHOOLS
INSPIRE ☆ STRIVE ☆ THRIVE

Mr. Jerry S. Boyd
Superintendent

405 W. College St.
Jonesborough, TN 37659
Phone (423) 753-1100

By submitting this bid, the bidder agrees that the quoted products and services meet the stated specifications and will remain in compliance with Washington County Board of Education standards throughout the contract period.

Bidder Information:

Printed Name: Patrick Counihan
Signature: *Patrick Counihan*
Telephone #: 864-277-8238
Cell #: 864-361-2531
Fax #: 864-299-8553
Company Name: Southern Flooring Inc
Mailing Address: 6820 Augusta Rd
City/State/ZIP: Greenville SC 29605
Date: 3-14-25
Email Address: patrickc@southernfloor.com

Exceptions (if any): No conditions or exceptions
If none, state "No conditions and/or exceptions."

Board of Directors

Eric Barnes
Annette Buchanan
Keith Ervin

Chad Fleenor
David Hammond
Gregg Huddleston

Mike Masters
Whitney Riddle
Vince Walters



WASHINGTON COUNTY SCHOOLS

INSPIRE ★ STRIVE ★ THRIVE

Mr. Jerry S. Boyd
Superintendent

405 W. College St.
Jonesborough, TN 37659
Phone (423) 753-1100

BID QUOTATION SHEET

Gym Floor Refinishing

Bid Opening: **Tuesday, March 18, 2025, at 2:00 PM EST**

The undersigned bidder acknowledges having read and understood the **Invitation to Bid** and specifications and agrees to comply with all stated terms and conditions. Upon award, the bidder will complete the refinishing of the gym flooring at **David Crockett High School** and **Lamar Elementary School** as outlined.

Bid Details

Lamar Elementary:

1. Repair/replacement of all damaged areas
2. Sand, seal & finish approximately 8,400 sq. ft.
3. Paint (1) Main Basketball Game Lines
4. Paint (1) Main Volleyball Game Lines
5. Paint (2) "Lamar" end-court lettering
6. Painted border
7. Paint center court logo
8. Paint (3) Four Square courts
9. Paint (2) 1-26 one-color numbers
10. Paint (2) A-Z one-color letters *\$23,998.00*

David Crockett High School:

1. Sand, seal & finish approximately 8,200 sq. ft.
2. Paint (1) Main Basketball Game Lines
3. Paint (1) Main Volleyball Game Lines
4. Paint (2) "David Crockett" end-court lettering
5. Paint free-throw lane
6. Painted border
7. Paint center court logo
8. Stain areas outside three-point lines
9. Mark corners of side volleyball courts

TOTAL BID AMOUNT: \$ 48,996.00

Board of Directors

Eric Barnes
Annette Buchanan
Keith Ervin

Chad Fleenor
David Hammond
Gregg Huddleston

Mike Masters
Whitney Riddle
Vince Walters

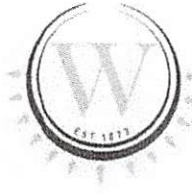

WASHINGTON
COUNTY SCHOOLS
INSPIRE * STRIVE * THRIVE

Mr. Jerry S. Boyd
Superintendent

405 W. College St.
Jonesborough, TN 37659
Phone (423) 753-1100

By submitting this bid, the bidder agrees that the quoted products and services meet the stated specifications and will remain in compliance with Washington County Board of Education standards throughout the contract period.

Bidder Information:

Printed Name: Harry Finchum
Signature: *Harry Finchum*
Telephone #: 865-453-3995
Cell #: 865-740-3514
Fax #: 865-429-2431
Company Name: Finchum Sports Fibers LLC
Mailing Address: 2812 Bald's Creek Hwy.
City/State/ZIP: Sevierville, TN 37876
Date: March 17, 2025
Email Address: lisa@finchumsportsfibers.com

Exceptions (if any): None
If none, state "No conditions and/or exceptions."

Board of Directors

Eric Barnes
Annette Buchanan
Keith Ervin

Chad Fleenor
David Hammond
Gregg Huddleston

Mike Masters
Whitney Riddle
Vince Walters



Proposal

2812 Boyds Creek Hwy
 Sevierville, TN 37876
 Office:(865)453-3995
 Fax:(865)429-2431

DATE March 14, 2025
Job Name Davie Crockett H.S.
Job Location Jonesborough, TN

Quotation valid until: April 14, 2025
Prepared by: Ritchie Stanley

Submitted to:
 Washington County Schools
 405 W. College St.
 Jonesborough, TN 37659

Michelle Stallard
stallardm@wcde.org

Architect: n/a
Sq. Footage: 10,388

Start Date:
Type of Floor: wood

Job Phone: (423) 426-0774
After Hours Contact:

Line Item	AMOUNT
To provide all labor, materials and services for the following: Sand and Refinish Gym; Machine sand with coarse, medium and fine grades of sandpaper to achieve a level, smooth, uniform surface. Remove sanding dust by vacuum. Apply 2 coats of sealer and 2 coats of modified oil base finish. 3 color graphics, lettering, game lines, stain and logo (Waterbase Stain with Oil base finish)	
TOTAL	\$ 24,998.00

Finchum Sports Flooring LLC

All material is guaranteed to be as specified. All work is to be completed in a substantial workmanlike manner according to specifications submitted per standard practices. Any alteration or deviation from above specifications involving material increase costs due to pandemic; extra costs will be executed only upon written orders and will become an extra charge over and above the contract. All agreements contingent upon circumstances such as strikes, accidents, pandemics or acts of God, or delays that are beyond our control. Owner is to carry fire, tornado, and other necessary insurance. Our workers are fully covered by Workers Compensation Insurance.

Estimator Signature

Ritchie Stanley

ACCEPTANCE OF PROPOSAL

The above prices, specifications, and conditions are satisfactory and are hereby accepted. Finchum Sports Floors, LLC. Is authorized to complete the work as specified.

SIGNATURE: _____ **Date of Acceptance:** _____



Proposal

2812 Boyds Creek Hwy
Sevierville, TN 37876
Office:(865)453-3995
Fax:(865)429-2431

DATE March 14, 2025
Job Name Lamar E.S.
Job Location Jonesborough, TN

Quotation valid until: April 14, 2025
Prepared by: Ritchie Stanley

Submitted to:
Washington County Schools
405 W. College St.
Jonesborough, TN 37659

Michelle Stallard
stallardm@wcde.org

Architect: n/a
Sq. Footage: 8,428

Start Date:
Type of Floor: wood

Job Phone: (423) 426-0774
After Hours Contact:

Line Item	AMOUNT
To provide all labor, materials and services for the following: Sand and Refinish Gym; Machine sand with coarse, medium and fine grades of sandpaper to achieve a level, smooth, uniform surface. Remove sanding dust by vacuum. Apply 2 coats of sealer and 2 coats of modified oil base finish. Repair approximately 120sqft of floor (1 1/2" wood floor) 3 color graphics, lettering, game line, and logo	
TOTAL	\$ 23,998.00

Finchum Sports Flooring LLC

All material is guaranteed to be as specified. All work is to be completed in a substantial workmanlike manner according to specifications submitted per standard practices. Any alteration or deviation from above specifications involving material increase costs due to pandemic; extra costs will be executed only upon written orders and will become an extra charge over and above the contract. All agreements contingent upon circumstances such as strikes, accidents, pandemics or acts of God, or delays that are beyond our control. Owner is to carry fire, tornado, and other necessary insurance. Our workers are fully covered by Workers Compensation Insurance.

Estimator Signature

Ritchie Stanley

ACCEPTANCE OF PROPOSAL

The above prices, specifications, and conditions are satisfactory and are hereby accepted. Finchum Sports Floors, LLC. Is authorized to complete the work as specified.

SIGNATURE: _____ **Date of Acceptance:** _____

Jerry S. Boyd
Superintendent



BOARD OF EDUCATION
Eric Barnes
Annette Buchanan
Keith Ervin
Chad Fleenor
David Hammond
Gregg Huddlestone
Mike Masters
Whitney Riddle
Vince Walters

A RESOLUTION BY THE WASHINGTON COUNTY BOARD OF EDUCATION

WHEREAS, the Washington County Board of Education is charged with governing the school system so that all students receive the best educational opportunities in order to graduate prepared to enter a postsecondary institution or the workforce; and

WHEREAS, the Tennessee General Assembly passed the “Education Freedom Act of 2025” during the first Extraordinary Session of the 114th General Assembly; and

WHEREAS, this Act includes a provision providing one-time bonuses of no less than \$2,000 to public school teachers in the state; and

WHEREAS, section four (4) of the “Education Freedom Act of 2025” requires that a local board of education for an LEA seeking to participate in section four (4) of the proposed act must affirm its intention to participate via a resolution in order to receive state funds to issue these bonuses;

THEREFORE, BE IT RESOLVED, That the Washington County Board of Education affirms its intention to participate in Section four (4) of the “Education Freedom Act of 2025,” relative to bonuses for teachers.

WASHINGTON COUNTY SCHOOL NUTRITION FY25 BUDGET

REVENUE		FY25 Budget CEP	Changes Increase/(Decrease)	FY25 Budget Amendment 1
40140	Interest	\$ 36,000		\$ 36,000
43521	Lunch Payments - Children	\$ 983,200	\$ (545,000)	\$ 438,200
43522	Lunch Payments - Adults	\$ -		\$ -
43523	Income from Breakfast	\$ -		\$ -
43525	A la Carte Sales	\$ -		\$ -
43990	Other Charges for Services	\$ 26,000		\$ 26,000
46990	State Matching	\$ 29,000		\$ 29,000
47111	USDA School Lunch Program	\$ 1,685,000	\$ 327,000	\$ 2,012,000
47112	USDA Commodities	\$ 290,166		\$ 290,166
47113	USDA Breakfast	\$ 445,600	\$ 269,000	\$ 714,600
47114	USDA Snack	\$ 60,000		\$ 60,000
47114	USDA Other/Supper Program	\$ 77,000		\$ 77,000
	Total Revenue Projected	3,631,966		3,682,966
39000	Fund Balance Reserves	\$ 1,273,563		1,782,676
	TOTAL ESTIMATED REVENUES & RESERVES	4,905,529		5,465,642
EXPENDITURES		FY25 Budget DRAFT 5-CEP	Changes Increase/(Decrease)	FY25 Budget Amendment 1
73100 105	Supervisor/Director	\$ 93,774		\$ 93,774
73100 165	Cafeteria Personnel	\$ 1,390,370	\$ 75,000	\$ 1,465,370
73100 201	Social Security	\$ 92,017	\$ 4,650	\$ 96,667
73100 204	State Retirement	\$ 185,518	\$ 9,375	\$ 194,893
73100 207	Medical Insurance	\$ 343,164		\$ 343,164
73100 210	Unemployment Compensation	\$ 2,000		\$ 2,000
73100 212	Employer Medicare	\$ 21,520	\$ 1,088	\$ 22,608
73100 355	Travel	\$ 15,000		\$ 15,000
73100 399	Other Contracted Services	\$ 290,000	\$ 50,000	\$ 340,000
73100 415	Electricity	\$ -		\$ -
73100 421	Food Preparation Supplies	\$ 200,000	\$ 20,000	\$ 220,000
73100 422	Food Supplies	\$ 1,500,000	\$ 400,000	\$ 1,900,000
73100 435	Office Supplies	\$ 8,000		\$ 8,000
73100 452	Utilities	\$ 6,000		\$ 6,000
73100 469	USDA Commodities	\$ 290,166		\$ 290,166
73100 499	Other Supplies and Materials	\$ 26,000		\$ 26,000
73100 509	Refunds	\$ 6,000		\$ 6,000
73100 524	Inservice/Staff Development	\$ 6,000		\$ 6,000
73100 710	Food Service Equipment/Capital Imp	\$ 430,000		\$ 430,000
99100-590	Transfer to Other Funds	\$ -		\$ -
	TOTAL EXPENDITURES	4,905,529		5,465,642
	Fund Balance Reserves Needed	1,273,563		1,782,676

<i>REQ DATE</i>
03/18/2025

Washington County Schools Nutrition

405 West College Street
 Jonesborough, TN 37659
 423-753-1107
 nutrition@wcde.org

<i>REQUISITION NUMBER</i>
1430250318

VENDOR KEY : GORDON F000
 SHIP DATE : 03/18/2025
 FISCAL YEAR : 2024-2025
 ENTERED BY : DEMELCON000

PRINTED 03/21/2025

VENDOR:
GORDON FOOD SERVICE
 PO Box 88029
 CHICAGO, IL 60680-1029

SHIP TO:
 Washington County Schools - Food Service
 405 W COLLEGE ST
 JONESBOROUGH, TN 37659

ATTN: CONSTANCE DEMELO

QUANTITY	UNIT	DESCRIPTION OF ITEMS OR MATERIALS	UNIT PRICE	AMOUNT
1		EXTENDED GFS- FOOD ONLY	300000.00000	300,000.00
		ACCOUNT SUMMARY (FOR INTERNAL USE)		
		ACCOUNT NUMBER	ACCOUNT AMOUNT	
		143 E 73100 422 000 00000 000	300,000.00	
			PAGE TOTAL	300,000.00
			TOTAL	300,000.00

This is a Requisition and not an official Purchase Order.
 The District is not financially responsible for the
 unauthorized purchases made with a Requisition.

GRANTS REQUEST

Reminder: Applied for EPA Clean School Bus Rebate Program (will be announced in May 2025) and VW STATE Grant (forecast)

<p>Electric Bus</p>	<p>Central States quote: 155Kw (STD Range) \$373,694.00. Infrastructure: The cost of the Evolution charging station is \$5373 quote. BridgeRidge's estimated cost is \$10,775.00 to connect one charging station at BCE. Two grants to pursue: 1. EPA Clean School Bus (CSB) Rebate Program (federal) due Jan 14th. One School Board member must sign the 2024 CBS Rebate Program School Board Awareness Certification, an example here, for the application. Buses serving school districts that are not prioritized ZE class 7 bus UPTO \$170,000 (bus + charging Infrastructure.)</p> <p>This grant is forecasted: would like to apply: 2. VW STATE GRANT is opening in January. - 75% towards the purchase of a new bus, and that would include infrastructure. The plan is to stack the general and federal awards to pay for the bus and infrastructure. These are matching grants; if only one is awarded, we and/or WCG will need to match the remainder of the funds for the project. Update: The EPA grant has been submitted.</p>
----------------------------	---

School-Based Mental Health Services Grant Program (forecast):

Would like to apply:

<p>School-Based Mental Health Services Grant Program</p>	<p>SMHS grant application will support the salaries of two Behavioral Interventionist, focusing on Tier II Behavioral support.</p>	<p>This forecasted grant opportunity requires non-Federal matching funds amounting at least 25% of their total project budget. This requirement promotes the sustainability of school-based mental health services. The budget that is being suggested for two Behavioral Intervention Specialists equals \$180,000-\$200,000 per year for 5 years. That would be a \$45,000-\$50,000 match (local funds) per year for 5 years. Please approve the 25% match requirement. Match may be in cash or possibly in-kind depending on new guidelines.</p>
---	--	---

Community Oriented Policing Services (COPS) School Violence Prevention Program (SVPP) (forecast):

Would like to apply in partnership with WCSO:

Community Oriented Policing Services (COPS) School Violence Prevention Program (SVPP)	The forecasted grant opportunity is three years (36 months) in duration for a maximum federal share of \$500,000 per award. There is a local cash match (cost share) requirement of at least 25 percent. The grant would be for \$666,666 total with \$500,000 being the federal grant and \$166,667. The district is looking into funding support for fencing and window bullet-resistant film for the schools' doors and windows. Please approve the 25% match requirement.
--	---



Return by June 15 to:
Director of Content
Andrew Johnson Tower, 11th floor
710 James Robertson Parkway Nashville, TN 37243-0379

**Certification of Adoption by
Local Board of Education**

The _____ Board of Education approved the City, County,
or Special School District adoption of the textbooks as indicated on the attached Local Adoption Report Abstract
during the meeting of the board on _____.

Month, Day, Year

If the LEA has chosen to adopt any materials not on contract, then we do hereby certify the following:

- The LEA's unique needs require adopting materials not on the state's official list.
- The materials adopted by this LEA were screened by a review committee, appointed in accordance with T.C.A. § 49-6-2207 and were determined to be aligned to the standards by evaluating the materials using the screening instrument approved by the Textbook and Instructional Materials Quality Commission.
- The adoption abstract, this certification of adoption, and the local panels' reviews will be posted to the LEA's website within 30 days of local board approval.
- All materials adopted by this LEA that are not on contract have been approved by waiver (if any waivers were granted, you must attach them to this form).
- The LEA agrees to furnish any materials requested by TDOE for review.

Date

Chairman, Board of Education

Date

Director of Schools



WASHINGTON
COUNTY SCHOOLS

INSPIRE ★ STRIVE ★ THRIVE

Mr. Jerry S. Boyd
Superintendent

405 W. College St.
Jonesborough, TN 37659
Phone (423) 753-1100

MEMORANDUM

TO: Washington County Board of Education
FROM: Washington County Schools Science Textbook Adoption Committee
DATE: March 18, 2025
SUBJECT: Recommendation for Science Textbook Adoption

The Washington County Schools Science Textbook Adoption Committee is pleased to recommend the adoption of the SAVVAS Science textbook series for grades K-12 as part of the science textbook adoption process prescribed by Tennessee State Law. After thorough review and evaluation, we are confident that this series aligns with the Tennessee Academic Standards and will provide our students with a high-quality, rigorous, and engaging science education.

The following grade-level adoptions are recommended:

- **K-5:** SAVVAS Elevate Elementary Science
- **6-8:** SAVVAS Elevate Middle Grades Science
- **9-12:** SAVVAS Tennessee Miller & Levine Experience Biology; Environmental Science: Your World, Your Turn; Tennessee Experience Chemistry 1 & 2; Experience Physics 1 & 2

This series not only meets state standards but also provides teachers with valuable instructional resources, assessment tools, and professional development opportunities to enhance student learning outcomes. Additionally, its digital and print resources support differentiated instruction, ensuring accessibility for all students, including those with special learning needs.

SAVVAS Science Materials will be available for you to review in the Conference Room of the District Office now through the April 3rd Board Meeting.

Thank you for your time and consideration. Please feel free to contact us should you require additional information regarding this recommendation.

Sincerely,
Washington County Schools Science Textbook Adoption Committee

Board of Directors

Eric Barnes
Annette Buchanan
Keith Ervin

Chad Fleenor
David Hammond
Gregg Huddleston

Mike Masters
Whitney Riddle
Vince Walters



Mr. Jerry S. Boyd
Superintendent

405 W. College St.
Jonesborough, TN 37659
Phone (423) 753-1100

Memorandum

Date: April 3, 2025

To: Washington County Board of Education
Mr. Jerry Boyd, Superintendent
Mr. Brad Hale, Chief Financial Officer

From: Dr. Josh Davis, Deputy Chief Academic Officer

Subject: Science Textbook Adoption-Request to Purchase

Please find attached (2) PO Requests for Purchase for the 2025 Science Textbook Adoption Materials. A breakdown of this request is listed below by grade band for your review and consideration.

K-2	Publisher SAVVAS	\$138,029
3-5	Publisher SAVVAS	\$256,360
6-8	Publisher SAVVAS	\$265,512
9-12	Publisher SAVVAS	\$141,661
9-12	Publisher Pearson	\$36,011

Total: \$837,573
Expected S&H: \$21,707

TN Book Company Purchase Order 4894

Board of Directors

Eric Barnes
Annette Buchanan
Keith Ervin

Chad Fleenor
David Hammond
Gregg Huddlestone

Mike Masters
Whitney Riddle
Vince Walters

TENNESSEE BOOK COMPANY

QUOTE

1550 HEIL QUAKER BLVD, STE 100
PO BOX 3009
LA VERGNE, TN 37086
615-793-5040

ADOPT

Number	332231
Date	04/02/2025
Page	1

Ship-to: 004
WASHINGTON CO.SCH MAINT. WHSE.
JOSHUA DAVIS
306 1/2 FOREST DRIVE
JONESBOROUGH TN 37659

Bill-to: 144
WASHINGTON COUNTY BD OF EDUC
JERRY BOYD, DIRECTOR
405 WEST COLLEGE STREET
JONESBOROUGH TN 37659

Ordered	Requested	Ordered By	Terms	Wh	Freight	Ship Via
04/02/2025	04/02/2025	144-WASHINGTON CO.	NET 30 DAYS	01	PREPAID	ID/LG AVERITT

Po #:	HOLD FOR PO	Ordered By:	JOSH DAVIS
-------	--------------------	-------------	-------------------

Item	Description	Isbn-13	Ordered	UM	Price	UM	Extension
T13460599	ELEVATE ELEM TN SCIENCE G/2 LI TERACY CONNECTIONS PKG 8Y	9798213460599	585	EA	83.00	EA	48555.00
T13460513	ELEVATE ELEM TN SCIENCE G/K LI TERACY CONNECTIONS PKG 8Y	9798213460513	539	EA	83.00	EA	44737.00
T13460551	ELEVATE ELEM TN SCIENCE G/1 LI TERACY CONNECTIONS PKG 8Y	9798213460551	539	EA	83.00	EA	44737.00
T13464627	ELEVATE ELEM TN SCIENCE G/5 CO MPREHENSIVE PKG & DIG LIC 8Y	9798213464627	581	EA	145.00	EA	84245.00
T13031911	Consisting of: ELEVATE ELEM TN SCIENCE G/5 SE	9798213031911	581	EA			
T13032000	ELEVATE ELEM TN SCIENCE G/5 TC AP ASSMT WB	9798213032000	581	EA			
T13464610	ELEVATE ELEM TN SCIENCE G/4 CO MPREHENSIVE PKG & DIG LIC 8Y	9798213464610	610	EA	145.00	EA	88450.00
T13031904	Consisting of: ELEVATE ELEM TN SCIENCE G/4 SE	9798213031904	610	EA			
T13031997	ELEVATE ELEM TN SCIENCE G/4 TC AP ASSMT WB	9798213031997	610	EA			
T13464603	ELEVATE ELEM TN SCIENCE G/3 CO MPREHENSIVE PKG & DIG LIC 8Y	9798213464603	577	EA	145.00	EA	83665.00
T13031898	Consisting of: ELEVATE ELEM TN SCIENCE G/3 SE	9798213031898	577	EA			
T13031980	ELEVATE ELEM TN SCIENCE G/3 TC AP ASSMT WB	9798213031980	577	EA			
T13072594	ELEVATE MID TN SCIENCE G/6 SE & DIG LIC 8Y	9798213072594	568	EA	156.00	EA	88608.00
T13032062	Consisting of: ELEVATE MID TN SCIENCE G/6 SE	9798213032062	568	EA			
T13032123	ELEVATE MID TN SCIENCE G/6 ENG INEERING DESIGN&TCAP ASSMT WB	9798213032123	568	EA			

Kellie Dumas

TENNESSEE BOOK COMPANY

QUOTE

1550 HEIL QUAKER BLVD, STE 100
PO BOX 3009
LA VERGNE, TN 37086
615-793-5040

ADOPT

Number	332231
Date	04/02/2025
Page	2

Ship-to: 004
WASHINGTON CO.SCH MAINT. WHSE.
JOSHUA DAVIS
306 1/2 FOREST DRIVE
JONESBOROUGH TN 37659

Bill-to: 144
WASHINGTON COUNTY BD OF EDUC
JERRY BOYD, DIRECTOR
405 WEST COLLEGE STREET
JONESBOROUGH TN 37659

Ordered	Requested	Ordered By	Terms	Wh	Freight	Ship Via
04/02/2025	04/02/2025	144-WASHINGTON CO.	NET 30 DAYS	01	PREPAID	ID/LG AVERITT

Po #:	HOLD FOR PO	Ordered By:	JOSH DAVIS
-------	--------------------	-------------	-------------------

Item	Description	Isbn-13	Ordered	UM	Price	UM	Extension
T13072624	ELEVATE MID TN SCIENCE G/7 SE & DIG LIC 8Y	9798213072624	547	EA	156.00	EA	85332.00
T13032079	ELEVATE MID TN SCIENCE G/7 SE	9798213032079	547	EA			
T13032130	ELEVATE MID TN SCIENCE G/7 ENG INEERING DESIGN&TCAP ASSMT WB	9798213032130	547	EA			
T13072655	ELEVATE MID TN SCIENCE G/8 SE & DIG LIC 8Y	9798213072655	587	EA	156.00	EA	91572.00
T13032086	ELEVATE MID TN SCIENCE G/8 SE	9798213032086	587	EA			
T13032147	ELEVATE MID TN SCIENCE G/8 ENG INEERING DESIGN&TCAP ASSMT WB	9798213032147	587	EA			
Entered by: PSW 04/02/25							
GRATIS MATERIALS WILL BE SHIPPED FROM THE PUBLISHER							

QUOTE

<i>Kellie Dumas</i>	Merchandise	Misc	Tax	Freight	Total Due
	659901.00	.00	.00	15656.00	675557.00

FRT\$15656

TENNESSEE BOOK COMPANY

QUOTE

1550 HEIL QUAKER BLVD, STE 100
PO BOX 3009
LA VERGNE, TN 37086
615-793-5040

ADOPT

Number	332232
Date	04/02/2025
Page	1

Ship-to: 004
WASHINGTON CO.SCH MAINT. WHSE.
JOSHUA DAVIS
306 1/2 FOREST DRIVE
JONESBOROUGH TN 37659

Bill-to: 144
WASHINGTON COUNTY BD OF EDUC
JERRY BOYD, DIRECTOR
405 WEST COLLEGE STREET
JONESBOROUGH TN 37659

Ordered	Requested	Ordered By	Terms	Wh	Freight	Ship Via
04/02/2025	04/02/2025	144-WASHINGTON CO.	NET 30 DAYS	01	PREPAID	AVERITT EXPRESS

Po #:	HOLD FOR PO	Ordered By:	JOSH DAVIS
-------	--------------------	-------------	-------------------

Item	Description	Isbn-13	Ordered	UM	Price	UM	Extension
T13464122	ENVIRONMENTAL SCI:YOUR WORLD Y OUR TURN HC SE & WB W/8YOA Consisting of:	9798213464122	80	EA	165.00	EA	13200.00
18336356	ENVIRONMENTAL SCIENCE 2021 SE	9781418336356	80	EA			
T18336370	ENVIRONMENTAL SCI: YOUR WORLD YOUR TURN 2021 STUDY WB	9781418336370	80	EA			
T13072563	TN EXPERIENCE CHEMISTRY 2026 H C SE & DIG LIC 8Y Consisting of:	9798213072563	285	EA	150.00	EA	42750.00
T13032017	TN EXPERIENCE CHEMISTRY 2026 H C SE	9798213032017	285	EA			
T13464085	EXPERIENCE PHYSICS 2022 HC SE & WB BNDL W/8YOA Consisting of:	9798213464085	75	EA	165.00	EA	12375.00
T18333966	EXPERIENCE PHYSICS 2022 HC SE	9781418333966	75	EA			
T18333980	EXPERIENCE PHYSICS 2022 MATH S KILLS WB	9781418333980	75	EA			
T13072532	MILLER & LEVINE TN EXPERIENCE BIOLOGY 2026 HC SE &DIG LIC 8Y Consisting of:	9798213072532	387	EA	189.50	EA	73336.50
T13032031	MILLER & LEVINE TN EXPERIENCE BIOLOGY 2026 G/9 HC SE	9798213032031	387	EA			
T13032055	MILLER & LEVINE TN EXPERIENCE BIOLOGY 2026 G/9 TCAP ASSMT WB	9798213032055	387	EA			
T13461411	MILLER & LEVINE TN EXPERIENCE FOUNDATIONS WB	9798213461411	387	EA			

Entered by: PSW 04/02/25

<i>Kellie Dumas</i>					

TENNESSEE BOOK COMPANY

QUOTE

1550 HEIL QUAKER BLVD, STE 100
PO BOX 3009
LA VERGNE, TN 37086
615-793-5040

ADOPT

Number	332232
Date	04/02/2025
Page	2

Ship-to: **004**
WASHINGTON CO.SCH MAINT. WHSE.
JOSHUA DAVIS
306 1/2 FOREST DRIVE
JONESBOROUGH TN 37659

Bill-to: **144**
WASHINGTON COUNTY BD OF EDUC
JERRY BOYD, DIRECTOR
405 WEST COLLEGE STREET
JONESBOROUGH TN 37659

Ordered	Requested	Ordered By	Terms	Wh	Freight	Ship Via
04/02/2025	04/02/2025	144-WASHINGTON CO.	NET 30 DAYS	01	PREPAID	AVERITT EXPRESS

Po #:	HOLD FOR PO	Ordered By:	JOSH DAVIS
-------	-------------	-------------	------------

Item	Description	Isbn-13	Ordered	UM	Price	UM	Extension
	GRATIS MATERIALS WILL BE SHIPPED FROM THE PUBLISHER						

QUOTE

<i>Kellie Dumas</i>	Merchandise	Misc	Tax	Freight	Total Due
	141661.50	.00	.00	4250.00	145911.50

FRT\$4250

TENNESSEE BOOK COMPANY

QUOTE

1550 HEIL QUAKER BLVD, STE 100
PO BOX 3009
LA VERGNE, TN 37086
615-793-5040

ADOPT

Number	331956
Date	03/20/2025
Page	1

Ship-to: 004
WASHINGTON CO.SCH MAINT. WHSE.
JOSHUA DAVIS
306 1/2 FOREST DRIVE
JONESBOROUGH TN 37659

Bill-to: 144
WASHINGTON COUNTY BD OF EDUC
JERRY BOYD, DIRECTOR
405 WEST COLLEGE STREET
JONESBOROUGH TN 37659

Ordered	Requested	Ordered By	Terms	Wh	Freight	Ship Via
03/20/2025	03/20/2025	144-WASHINGTON CO.	NET 30 DAYS	01	PREPAID	AVERITT EXPRESS

Po #:	HOLD FOR PO	Ordered By:	JOSHUA DAVIS
-------	--------------------	-------------	--------------

Item	Description	Isbn-13	Ordered	UM	Price	UM	Extension
78996856	GLEN EARTH SCI CLSRM SET 25 TB Consisting of:	9780078996856	1	EA	2025.00	EA	2025.00
76774913	GLEN EARTH SCI TB	9780076774913	25	EA			
76774920	GLEN EARTH SCI TE	9780076774920	1	EA	120.90	EA	120.90
34677293	ANATOMY PHYSIOLOGY & DISEASE 4 E TB W/6YOA	9780134677293	60	EA	102.47	EA	6148.20
34761381	PH ANATOMY PHYSIOLOGY & DISEAS E 4E UTRP Consisting of:	9780134761381	4	EA	104.94	EA	419.76
34721606	ANATOMY PHYSIOLOGY & DISEASE 4 E TWE	9780134721606	4	EA			
34433691	CAMPBELL AP BIOLOGY 11E TB W/6 YOA	9780134433691	45	EA	167.47	EA	7536.15
34809526	CAMPBELL AP BIOLOGY 11E TN UTR P Consisting of:	9780134809526	3	EA	98.38	EA	295.14
34478616	INQUIRY IN ACTION:INTERPRETING SCIENTIFIC PAPERS 3E WB	9780134478616	3	EA			
34478647	CAMPBELL AP BIOLOGY 11E PRINTE D TEST BANK	9780134478647	3	EA			
34546902	PREPARING FOR THE BIOLOGY AP E XAM 6E WB	9780134546902	3	EA			
34459509	CAMPBELL AP BIOLOGY 11E EXAMVI EW ASSMT SUITE	9780134459509	3	EA			
34650951	PH CHEMISTRY:CENTRAL SCI AP 14 E TB W/ETEXT 6YR	9780134650951	45	EA	167.97	EA	7558.65
34809533	PH CHEMISTRY:CENTRAL SCI AP 14 E UTRP Consisting of:	9780134809533	3	EA	36.44	EA	109.32
34552248	PH CHEMISTRY:CENTRAL SCI AP 14	9780134552248	3	EA			

Kellie Dumas

TENNESSEE BOOK COMPANY

QUOTE

1550 HEIL QUAKER BLVD, STE 100
PO BOX 3009
LA VERGNE, TN 37086
615-793-5040

ADOPT

Number	331956
Date	03/20/2025
Page	2

Ship-to: 004
WASHINGTON CO.SCH MAINT. WHSE.
JOSHUA DAVIS
306 1/2 FOREST DRIVE
JONESBOROUGH TN 37659

Bill-to: 144
WASHINGTON COUNTY BD OF EDUC
JERRY BOYD, DIRECTOR
405 WEST COLLEGE STREET
JONESBOROUGH TN 37659

Ordered	Requested	Ordered By	Terms	Wh	Freight	Ship Via
03/20/2025	03/20/2025	144-WASHINGTON CO.	NET 30 DAYS	01	PREPAID	AVERITT EXPRESS

Po #:	HOLD FOR PO	Ordered By:	JOSHUA DAVIS
-------	--------------------	-------------	--------------

Item	Description	Isbn-13	Ordered	UM	Price	UM	Extension
34661483	E COMPLETE SOLUTIONS EXERCISES PH CHEMISTRY:CENTRAL SCI AP TE ST PREP WB	9780134661483	3	EA			
33539677	PH COLLEGE PHYSICS:STRATEGIC A PPROACH 3E AP TB W/6YOA	9780133539677	25	EA	167.97	EA	4199.25
34794747	PH COLLEGE PHYSICS:STRATEGIC A PPROACH 3E UTRP	9780134794747	2	EA	100.97	EA	201.94
21907257	Consisting of: PH COLLEGE PHYSICS:STRATEGIC A PPROACH 3E IR DVD	9780321907257	2	EA			
64108686	ENVIRONMENTAL SCI 2E AP TB	9781464108686	35	EA	182.98	EA	6404.30
64156182	ENVIRONMENTAL SCI 2E TE Entered by: PSW 03/20/25	9781464156182	2	EA	495.98	EA	991.96
GRATIS MATERIALS WILL BE SHIPPED FROM THE PUBLISHER							

QUOTE

<i>Kellie Dumas</i>	Merchandise	Misc	Tax	Freight	Total Due
	36010.57	.00	.00	1801.00	37811.57

FRT\$1801

PURCHASING DEPARTMENT
WASHINGTON COUNTY BOARD OF EDUCATION

Purchase Order **No 4894**

Date Issued **4/1/25**

Appropriation No. **K1E71100-449**

Dept. **Academics**

School **CO**

PURCHASE ORDER

TO **TN Book Company**

Deliver to **WCDE**

Address: **306 1/2 Forest Drive**

Via **Jonesborough, TN 37659**

NOTICE TO VENDOR

1. Purchase order **MUST** bear two signatures in order to be valid.
2. Purchase order number **MUST** appear on all invoices submitted for payment.
3. Mail **TWO** copies of your invoice promptly to:

Washington County Board of Education
405 West College Street
Jonesborough, TN 37659
Telephone (423) 753-1105

Articles on this order must be charged to account of

ARTICLES OR SERVICES	CODE	QUANTITY & UNIT	UNIT PRICE	TOTAL
(Unless otherwise stated all prices F.O.B. Destination)				
Science Textbooks (See quote attached) # 837,573 S+H \$ 17,457 21,707 JD JD 855,030 #859,280 ⁰⁷				
GRAND TOTAL - INCLUDING ALL ATTACHED PAGES				JD #27,011 ⁵⁷ #53,011

SUBJECT TO THE FOLLOWING CONDITIONS

1. All packages, cartons or other containers must be plainly marked with the purchase order number.
 2. The right is reserved to purchase in the open market and to charge the difference to the Vendor in the event that deliveries are not made at the time specified in the bid and on this order.
 3. Whenever a delivery is rejected, the Vendor shall be notified and be given the reason for the rejection. All rejected deliveries shall be held at the Vendor's risk and he shall bear the expense of removal.
 4. Acceptance of this order includes acceptance of all terms, prices, delivery, instructions, specifications and conditions stated.
 5. The county is not liable for Federal excise tax or state sales tax.
 6. Each shipment and/or each purchase order should be covered by separate invoice.
- IMPORTANT: INVOICES AND PACKAGES MUST BEAR PURCHASE ORDER NUMBER**

VENDOR'S COPY	There is an otherwise unincumbered balance to the credit of the proper appropriation, allotment or fund to meet the expenditure covered by this purchase.	APPROVED:
	Authorized Signature	Purchasing Agent



WASHINGTON
COUNTY SCHOOLS
 INSPIRE ★ STRIVE ★ THRIVE

Mr. Jerry S. Boyd
 Superintendent

405 W. College St.
 Jonesborough, TN 37659
 Phone (423) 753-1100

Memorandum

Date: April 3, 2025

To: Washington County Board of Education
 Mr. Jerry Boyd, Superintendent
 Mr. Brad Hale, Chief Financial Officer

From: Dr. Josh Davis, Deputy Chief Academic Officer

Subject: Science Textbook Adoption-Request to Purchase

Please find attached (2) PO Requests for Purchase for the 2025 Science Textbook Adoption Materials. A breakdown of this request is listed below by grade band for your review and consideration.

K-2	Publisher SAVVAS	\$138,029
3-5	Publisher SAVVAS	\$256,360
6-8	Publisher SAVVAS	\$265,512
9-12	Publisher SAVVAS	\$141,661
9-12	Publisher Pearson	\$36,011

Total: \$837,573
 Expected S&H: \$21,707

\$859,280⁰⁷

WBA

TN Book Company Purchase Order 4893

Board of Directors

Eric Barnes
 Annette Buchanan
 Keith Ervin

Chad Fleenor
 David Hammond
 Gregg Huddleston

Mike Masters
 Whitney Riddle
 Vince Walters

TENNESSEE BOOK COMPANY

QUOTE

1550 HEIL QUAKER BLVD, STE 100
PO BOX 3009
LA VERGNE, TN 37086
615-793-5040

ADOPT

Number	332231
Date	04/02/2025
Page	1

Ship-to: 004
WASHINGTON CO.SCH MAINT. WHSE.
JOSHUA DAVIS
306 1/2 FOREST DRIVE
JONESBOROUGH TN 37659

Bill-to: 144
WASHINGTON COUNTY BD OF EDUC
JERRY BOYD, DIRECTOR
405 WEST COLLEGE STREET
JONESBOROUGH TN 37659

Ordered	Requested	Ordered By	Terms	Wh	Freight	Ship Via
04/02/2025	04/02/2025	144-WASHINGTON CO.	NET 30 DAYS	01	PREPAID	ID/LG AVERITT

Po #:	HOLD FOR PO	Ordered By	JOSH DAVIS
-------	--------------------	------------	-------------------

Item	Description	Isbn-13	Ordered	UM	Price	UM	Extension
T13460599	ELEVATE ELEM TN SCIENCE G/2 LI TERACY CONNECTIONS PKG 8Y	9798213460599	585	EA	83.00	EA	48555.00
T13460513	ELEVATE ELEM TN SCIENCE G/K LI TERACY CONNECTIONS PKG 8Y	9798213460513	539	EA	83.00	EA	44737.00
T13460551	ELEVATE ELEM TN SCIENCE G/1 LI TERACY CONNECTIONS PKG 8Y	9798213460551	539	EA	83.00	EA	44737.00
T13464627	ELEVATE ELEM TN SCIENCE G/5 CO MPREHENSIVE PKG & DIG LIC 8Y	9798213464627	581	EA	145.00	EA	84245.00
T13031911	Consisting of: ELEVATE ELEM TN SCIENCE G/5 SE	9798213031911	581	EA			
T13032000	ELEVATE ELEM TN SCIENCE G/5 TC AP ASSMT WB	9798213032000	581	EA			
T13464610	ELEVATE ELEM TN SCIENCE G/4 CO MPREHENSIVE PKG & DIG LIC 8Y	9798213464610	610	EA	145.00	EA	88450.00
T13031904	Consisting of: ELEVATE ELEM TN SCIENCE G/4 SE	9798213031904	610	EA			
T13031997	ELEVATE ELEM TN SCIENCE G/4 TC AP ASSMT WB	9798213031997	610	EA			
T13464603	ELEVATE ELEM TN SCIENCE G/3 CO MPREHENSIVE PKG & DIG LIC 8Y	9798213464603	577	EA	145.00	EA	83665.00
T13031898	Consisting of: ELEVATE ELEM TN SCIENCE G/3 SE	9798213031898	577	EA			
T13031980	ELEVATE ELEM TN SCIENCE G/3 TC AP ASSMT WB	9798213031980	577	EA			
T13072594	ELEVATE MID TN SCIENCE G/6 SE & DIG LIC 8Y	9798213072594	568	EA	156.00	EA	88608.00
T13032062	Consisting of: ELEVATE MID TN SCIENCE G/6 SE	9798213032062	568	EA			
T13032123	ELEVATE MID TN SCIENCE G/6 ENG INEERING DESIGN&TCAP ASSMT WB	9798213032123	568	EA			

Kellie Dumas

TENNESSEE BOOK COMPANY

QUOTE

1550 HEIL QUAKER BLVD, STE 100
PO BOX 3009
LA VERGNE, TN 37086
615-793-5040

ADOPT

Number	332231
Date	04/02/2025
Page	2

Ship-to: 004
WASHINGTON CO.SCH MAINT. WHSE.
JOSHUA DAVIS
306 1/2 FOREST DRIVE
JONESBOROUGH TN 37659

Bill-to: 144
WASHINGTON COUNTY BD OF EDUC
JERRY BOYD, DIRECTOR
405 WEST COLLEGE STREET
JONESBOROUGH TN 37659

Ordered	Requested	Ordered By	Terms	Wh	Freight	Ship Via
04/02/2025	04/02/2025	144-WASHINGTON CO.	NET 30 DAYS	01	PREPAID	ID/LG AVERITT

Po #:	HOLD FOR PO	Ordered By	JOSH DAVIS
-------	-------------	------------	------------

Item	Description	Isbn-13	Ordered	UM	Price	UM	Extension
T13072624	ELEVATE MID TN SCIENCE G/7 SE & DIG LIC 8Y Consisting of:	9798213072624	547	EA	156.00	EA	85332.00
T13032079	ELEVATE MID TN SCIENCE G/7 SE	9798213032079	547	EA			
T13032130	ELEVATE MID TN SCIENCE G/7 ENG INEERING DESIGN&TCAP ASSMT WB	9798213032130	547	EA			
T13072655	ELEVATE MID TN SCIENCE G/8 SE & DIG LIC 8Y Consisting of:	9798213072655	587	EA	156.00	EA	91572.00
T13032086	ELEVATE MID TN SCIENCE G/8 SE	9798213032086	587	EA			
T13032147	ELEVATE MID TN SCIENCE G/8 ENG INEERING DESIGN&TCAP ASSMT WB	9798213032147	587	EA			
Entered by: PSW 04/02/25							
GRATIS MATERIALS WILL BE SHIPPED FROM THE PUBLISHER							

<i>Kellie Dumas</i>	Merchandise	Misc	Tax	Freight	Total Due
	659901.00	.00	.00	15656.00	675557.00

FRTS15656

TENNESSEE BOOK COMPANY

QUOTE

1550 HEIL QUAKER BLVD, STE 100
PO BOX 3009
LA VERGNE, TN 37086
615-793-5040

ADOPT

Number	332232
Date	04/02/2025
Page	1

Ship-to: 004 WASHINGTON CO.SCH MAINT. WHSE. JOSHUA DAVIS 306 1/2 FOREST DRIVE JONESBOROUGH TN 37659	Bill-to: 144 WASHINGTON COUNTY BD OF EDUC JERRY BOYD, DIRECTOR 405 WEST COLLEGE STREET JONESBOROUGH TN 37659
---	--

Ordered	Requested	Ordered By	Terms	Wh	Freight	Ship Via
04/02/2025	04/02/2025	144-WASHINGTON CO.	NET 30 DAYS	01	PREPAID	AVERITT EXPRESS

Po #:	HOLD FOR PO	Ordered By	JOSH DAVIS
-------	-------------	------------	------------

Item	Description	Isbn-13	Ordered	UM	Price	UM	Extension
T13464122	ENVIRONMENTAL SCI:YOUR WORLD Y OUR TURN HC SE & WB W/8YOA Consisting of:	9798213464122	80	EA	165.00	EA	13200.00
18336356	ENVIRONMENTAL SCIENCE 2021 SE	9781418336356	80	EA			
T18336370	ENVIRONMENTAL SCI: YOUR WORLD YOUR TURN 2021 STUDY WB	9781418336370	80	EA			
T13072563	TN EXPERIENCE CHEMISTRY 2026 H C SE & DIG LIC 8Y Consisting of:	9798213072563	285	EA	150.00	EA	42750.00
T13032017	TN EXPERIENCE CHEMISTRY 2026 H C SE	9798213032017	285	EA			
T13464085	EXPERIENCE PHYSICS 2022 HC SE & WB BNDL W/8YOA Consisting of:	9798213464085	75	EA	165.00	EA	12375.00
T18333966	EXPERIENCE PHYSICS 2022 HC SE	9781418333966	75	EA			
T18333980	EXPERIENCE PHYSICS 2022 MATH S KILLS WB	9781418333980	75	EA			
T13072532	MILLER & LEVINE TN EXPERIENCE BIOLOGY 2026 HC SE & DIG LIC 8Y Consisting of:	9798213072532	387	EA	189.50	EA	73336.50
T13032031	MILLER & LEVINE TN EXPERIENCE BIOLOGY 2026 G/9 HC SE	9798213032031	387	EA			
T13032055	MILLER & LEVINE TN EXPERIENCE BIOLOGY 2026 G/9 TCAP ASSMT WB	9798213032055	387	EA			
T13461411	MILLER & LEVINE TN EXPERIENCE FOUNDATIONS WB	9798213461411	387	EA			
Entered by: PSW 04/02/25							

Kellie Dumas

TENNESSEE BOOK COMPANY

QUOTE

1550 HEIL QUAKER BLVD, STE 100
PO BOX 3009
LA VERGNE, TN 37086
615-793-5040

ADOPT

Number	332232
Date	04/02/2025
Page	2

Ship-to: 004
WASHINGTON CO.SCH MAINT. WHSE.
JOSHUA DAVIS
306 1/2 FOREST DRIVE
JONESBOROUGH TN 37659

Bill-to: 144
WASHINGTON COUNTY BD OF EDUC
JERRY BOYD, DIRECTOR
405 WEST COLLEGE STREET
JONESBOROUGH TN 37659

Ordered	Requested	Ordered By	Terms	Wh	Freight	Ship Via
04/02/2025	04/02/2025	144-WASHINGTON CO.	NET 30 DAYS	01	PREPAID	AVERITT EXPRESS

<i>Po #:</i>	HOLD FOR PO	<i>Ordered By:</i>	JOSH DAVIS
--------------	-------------	--------------------	------------

Item	Description	Isbn-13	Ordered	UM	Price	UM	Extension
	GRATIS MATERIALS WILL BE SHIPPED FROM THE PUBLISHER						

QUOTE

<i>Kellie Dumas</i>	Merchandise	Misc	Tax	Freight	Total Due
	141661.50	.00	.00	4250.00	145911.50

FRT\$4250

TENNESSEE BOOK COMPANY

QUOTE

1550 HEIL QUAKER BLVD, STE 100
PO BOX 3009
LA VERGNE, TN 37086
615-793-5040

ADOPT

Number	331956
Date	03/20/2025
Page	1

Ship-to: 004
WASHINGTON CO.SCH MAINT. WHSE.
JOSHUA DAVIS
306 1/2 FOREST DRIVE
JONESBOROUGH TN 37659

Bill-to: 144
WASHINGTON COUNTY BD OF EDUC
JERRY BOYD, DIRECTOR
405 WEST COLLEGE STREET
JONESBOROUGH TN 37659

Ordered	Requested	Ordered By	Terms	Wh	Freight	Ship Via
03/20/2025	03/20/2025	144-WASHINGTON CO.	NET 30 DAYS	01	PREPAID	AVERITT EXPRESS

Po #:	HOLD FOR PO	Ordered By	JOSHUA DAVIS
-------	-------------	------------	--------------

Item	Description	Isbn-13	Ordered	UM	Price	UM	Extension
78996856	GLEN EARTH SCI CLSRM SET 25 TB	9780078996856	1	EA	2025.00	EA	2025.00
	Consisting of:						
76774913	GLEN EARTH SCI TB	9780076774913	25	EA			
76774920	GLEN EARTH SCI TE	9780076774920	1	EA	120.90	EA	120.90
34677293	ANATOMY PHYSIOLOGY & DISEASE 4	9780134677293	60	EA	102.47	EA	6148.20
	E TB W/6YOA						
34761381	PH ANATOMY PHYSIOLOGY & DISEAS	9780134761381	4	EA	104.94	EA	419.76
	E 4E UTRP						
	Consisting of:						
34721606	ANATOMY PHYSIOLOGY & DISEASE 4	9780134721606	4	EA			
	E TWE						
34433691	CAMPBELL AP BIOLOGY 11E TB W/6	9780134433691	45	EA	167.47	EA	7536.15
	YOA						
34809526	CAMPBELL AP BIOLOGY 11E TN UTR	9780134809526	3	EA	98.38	EA	295.14
	P						
	Consisting of:						
34478616	INQUIRY IN ACTION:INTERPRETING	9780134478616	3	EA			
	SCIENTIFIC PAPERS 3E WB						
34478647	CAMPBELL AP BIOLOGY 11E PRINTE	9780134478647	3	EA			
	D TEST BANK						
34546902	PREPARING FOR THE BIOLOGY AP E	9780134546902	3	EA			
	XAM 6E WB						
34459509	CAMPBELL AP BIOLOGY 11E EXAMVI	9780134459509	3	EA			
	EW ASSMT SUITE						
34650951	PH CHEMISTRY:CENTRAL SCI AP 14	9780134650951	45	EA	167.97	EA	7558.65
	E TB W/ETEXT 6YR						
34809533	PH CHEMISTRY:CENTRAL SCI AP 14	9780134809533	3	EA	36.44	EA	109.32
	E UTRP						
	Consisting of:						
34552248	PH CHEMISTRY:CENTRAL SCI AP 14	9780134552248	3	EA			

Kellie Dumas

TENNESSEE BOOK COMPANY

QUOTE

1550 HEIL QUAKER BLVD, STE 100
PO BOX 3009
LA VERGNE, TN 37086
615-793-5040

ADOPT

Number	331956
Date	03/20/2025
Page	2

Ship-to: 004
WASHINGTON CO.SCH MAINT. WHSE.
JOSHUA DAVIS
306 1/2 FOREST DRIVE
JONESBOROUGH TN 37659

Bill-to: 144
WASHINGTON COUNTY BD OF EDUC
JERRY BOYD, DIRECTOR
405 WEST COLLEGE STREET
JONESBOROUGH TN 37659

Ordered	Requested	Ordered By	Terms	Wh	Freight	Ship Via
03/20/2025	03/20/2025	144-WASHINGTON CO.	NET 30 DAYS	01	PREPAID	AVERITT EXPRESS

Po #:	HOLD FOR PO	Ordered By:	JOSHUA DAVIS
-------	--------------------	-------------	--------------

Item	Description	Isbn-13	Ordered	UM	Price	UM	Extension
34661483	E COMPLETE SOLUTIONS EXERCISES PH CHEMISTRY:CENTRAL SCI AP TE ST PREP WB	9780134661483	3	EA			
33539677	PH COLLEGE PHYSICS:STRATEGIC A PPROACH 3E AP TB W/6YOA	9780133539677	25	EA	167.97	EA	4199.25
34794747	PH COLLEGE PHYSICS:STRATEGIC A PPROACH 3E UTRP	9780134794747	2	EA	100.97	EA	201.94
21907257	Consisting of: PH COLLEGE PHYSICS:STRATEGIC A PPROACH 3E IR DVD	9780321907257	2	EA			
64108686	ENVIRONMENTAL SCI 2E AP TB	9781464108686	35	EA	182.98	EA	6404.30
64156182	ENVIRONMENTAL SCI 2E TE Entered by: PSW 03/20/25	9781464156182	2	EA	495.98	EA	991.96
GRATIS MATERIALS WILL BE SHIPPED FROM THE PUBLISHER							

QUOTE

<i>Kellie Dumas</i>	Merchandise	Misc	Tax	Freight	Total Due
	36010.57	.00	.00	1801.00	37811.57

FRTS1801

PURCHASING DEPARTMENT
WASHINGTON COUNTY BOARD OF EDUCATION

Purchase Order **№ 4900**

Date Issued **3/20/25**

Appropriation No. **141-E-76100-707-002**

Dept. **ISM grant**

School **Gray**

PURCHASE ORDER

TO Tailored closet
 4081 Hwy 11E
 Bluff city, TN 37618

Deliver to **Gray Elementary school**
 Address **755 Gray station Rd.**
Gray, TN 37615
 Via **Christine Lewis**

Articles on this order must be charged to account of

NOTICE TO VENDOR

- 1. Purchase order MUST bear two signatures in order to be valid.**
- 2. Purchase order number MUST appear on all invoices submitted for payment.**
- 3. Mail TWO copies of your invoice promptly to:**

Washington County Board of Education
405 West College Street
Jonesborough, TN 37659
Telephone (423) 753-1105

ARTICLES OR SERVICES	CODE	QUANTITY & UNIT	UNIT PRICE	TOTAL
(Unless otherwise stated all prices F.O.B. Destination)				
Epoxy Floor installation				\$10,000.00
Tile Removal				\$2,600.00
price inquiry attached				
GRAND TOTAL - INCLUDING ALL ATTACHED PAGES				\$12,600.00

SUBJECT TO THE FOLLOWING CONDITIONS

1. All packages, cartons or other containers must be plainly marked with the purchase order number.
2. The right is reserved to purchase in the open market and to charge the difference to the Vendor in the event that deliveries are not made at the time specified in the bid and on this order.
3. Whenever a delivery is rejected, the Vendor shall be notified and be given the reason for the rejection. All rejected deliveries shall be held at the Vendor's risk and he shall bear the expense of removal.
4. Acceptance of this order includes acceptance of all terms, prices, delivery, instructions, specifications and conditions stated.
5. The county is not liable for Federal excise tax or state sales tax.
6. Each shipment and/or each purchase order should be covered by separate invoice.

IMPORTANT: INVOICES AND PACKAGES MUST BEAR PURCHASE ORDER NUMBER

VENDOR'S COPY

There is an otherwise unincumbered balance to the credit of the proper appropriation, allotment or fund to meet the expenditure covered by this purchase.

Authorized Signature

APPROVED:

Purchasing Agent

KL



PRICE INQUIRY FORM

VENDOR	DESCRIPTION OF ITEM FOR PRICE COMPARISON	PRICE QUOTED
Firm - <u>Tailored Closet</u> Address- <u>4081 Hwy 11 E Bluff</u> <u>City, TN 37618</u> Person _____ Date - <u>3/17/25</u>	Removal of tile & adding new epoxy-flake floor coating	Total: \$12,600.00
Firm: <u>Tri Cities Epoxy Floors</u> Address: <u>194 Tucker St. Gate</u> <u>City, VA 24251</u> Person- <u>Daniel Mitchell</u> Date - <u>3/17/25</u>	Classroom epoxy and flake system, cove base, etc.	Total: \$15,236.46
Firm - <u>Team Red Coatings</u> Address - Person- Date - <u>3/6/25</u>	Classroom epoxy flooring	Total: Requested quote but company did not show up to provide an estimate

Name of person obtaining inquiry - Kelli Hauldren

P R O P O S A L

Tailored Closet-PremierGarage of Tri-Cities-TN, Boone,
Asheville
4081 Hwy 11 E
Bluff City, TN 37618
(423) 557-4450

<https://tailoredcloset.com/near-me/tri-cities-tn/>
<https://www.premiergarage.com/near-me/tri-cities-tn/>



Billing/Service Address

Christie Lewis
755 Gray Station Rd
Gray, TN 37615
(423) 943-4923
lewisc2@wcde.org

Date	March 14, 2025
------	----------------

P G F L O O R I N G - D E C O R A T I V E F L A K E

This proposal expires on 3/28/2025

Prepared by William Leonard (william.leonard@tailoredcloset.com)

N O T E S

Hey Christie!

Thank you for considering Premier Garage for your garage flooring needs. We are delighted to offer our expertise in providing high-quality, durable, and aesthetically pleasing flooring solutions that will transform your garage into a functional and visually appealing space.

Please look over the designs and proposal and let me know if you have any questions or any changes you'd like to see or how you want to proceed.

Should you choose to move forward with your project and you have no further questions or changes, please read carefully the bullet points in the Terms & Conditions section, and then click on the orange "Accept" icon just below the total price. This will take you to the sign-off section. Type your name where requested, sign, and enter your credit card details for the 50% non-refundable deposit. Please let me know if you'd prefer to pay your deposit in some other manner, in which

case I need to make a slight change in order for the system to allow you to accept without providing credit card details.

We would tentatively schedule your installation (subject to receipt of materials and other circumstances outside our control) once we have received your acceptance and deposit.

If you have any questions, please give me a call or text me at 4233060979 or send me an email at the email address above.

Thanks!

Item	Description	Room	Details	Rate	Amount
Installation-PG Commercial Flooring	Commercial Flooring Installation				
PremierOne Decorative Textures Flooring	Please see selections below COLOR: Iced Coffee FLAKE SIZE: 1/4 STEMWALL SF: N/A CURRENT CONDITIONS Existing Surface: Tile Cracking: Unknown Tramex Reading: N/A Joints: N/A Obstructions: Customer to remove all items from floor FLOOR COATING PLAN Moisture Barrier: None Stemwall: None Termination Point: Entire Room Apron: N/A Outlets in the floor to be covered			10000.00	\$10,000.00
Commercial Flooring	CTE Room Tile Removal			2600.00	\$2,600.00

Subtotal	\$12,600.00
Tax	\$0.00
Total	\$12,600.00

F I N A N C I N G

Split the cost into easy monthly payments with  HEARTH

As low as **\$252/month** based on the price of \$12,600.00 at 0% annual percentage rate (APR) for the first 15 months.

Click [here](#) to see your monthly payment options.

- Instant prequalification
- Rates from 0% APR*
- Checking eligibility does not impact your credit score

*After 0% introductory period, your APR will be between 14.99%-29.99%, based on your creditworthiness. This APR will vary with the market based on the U.S. Prime Rate. Your monthly payment for the 0% options will be determined by creditworthiness. **All financing is subject to credit approval. Your terms may vary. Payment options through Hearth are provided by our lending partners. For example: a \$7,500 purchase could cost \$237/month for 36 months based on an 8.5% APR. Offers are based on creditworthiness.

Commercial

[View rescission terms...](#)

Click [here](#) if you no longer wish to receive notifications or related information about this proposal.

Invoice

Tax invoice



Tri Cities Epoxy Floors , 194 Tucker St , Gate City VA 24251, United States

BILL TO

Gray Elementary school
755 Gray Station Rd
Gray TN 37615
United States

Invoice No.: 161
Issue date: Mar 3, 2025
Due date: Mar 16, 2025
Payment method: Check/cheque

Invoice No.: 161	Issue date: Mar 3, 2025	Due date: Mar 16, 2025	Total due (USD) \$15,236.46
----------------------------	-----------------------------------	----------------------------------	---------------------------------------

Description	Qty.	Unit price (USD)	TAX (USD)	Amount (USD)
Classroom epoxy and flake system Floor prep Flood coat installation Broadcast receiver coat installation Full broadcast Cabin fever 1/4" flake Polyaspartic sealer installation Ballistix squire 2.0 spray application	1.0	8,480.00	0.00	8,480.00
4" Epoxy Cove Base Prep wall Installation of epoxy cove base Coat cove base with epoxy Full broadcast Cabin fever 1/4" flake Seal cove base	1.0	1,400.00	0.00	1,400.00
Tuffboy 7100 epoxy 100% solids gray epoxy 3 gallon kit	11.0	180.00	0.00	1,980.00
Cabin fever 1/4" flake 40 lb box	6.0	125.00	0.00	750.00
Tuffboy 7300 Polyaspartic 2 gallon kit	6.0	185.00	0.00	1,110.00
Ballistix squire 2.0 Top coat	2.0	508.23	0.00	1,016.46

Description	Qty.	Unit price (USD)	TAX (USD)	Amount (USD)
Tuffboy epoxy cove base Kit	4.0	125.00	0.00	500.00
Subtotal				\$15,236.46
Total (USD)				\$15,236.46

 Daniel Mitchell

 4234802104

Tri Cities Epoxy Floors
194 Tucker St
Gate City VA 24251
United States

PURCHASING DEPARTMENT
WASHINGTON COUNTY BOARD OF EDUCATION

Purchase Order **№ 4899**

Date Issued **3/20/25**

Appropriation No. **141-E-71300-730-002**

Dept. **ISM grant**

School **Gray**

PURCHASE ORDER

TO Paxton / Patterson
 4141 W. 126th Street
 Alsip, IL 60803

Deliver to **Gray Elementary**
 Address **755 Gray Station Rd.**
Gray, TN 37615
 Via **Christine Lewis**

Articles on this order must be charged to account of

NOTICE TO VENDOR

1. Purchase order **MUST** bear two signatures in order to be valid.
2. Purchase order number **MUST** appear on all invoices submitted for payment.
3. Mail **TWO** copies of your invoice promptly to:

Washington County Board of Education
 405 West College Street
 Jonesborough, TN 37659
 Telephone (423) 753-1105

ARTICLES OR SERVICES	CODE	QUANTITY & UNIT	UNIT PRICE	TOTAL
(Unless otherwise stated all prices F.O.B. Destination)				
Intro to Health Science				\$4,295.00
Mental Health				\$2,395.00
Therapeutic services				\$4,695.00
HVAC				\$4,995.00
Video Production				\$4,495.00
Setup & Assembly				\$2,000.00
<i>*sole source attached*</i>				
GRAND TOTAL - INCLUDING ALL ATTACHED PAGES				\$22,875.00

SUBJECT TO THE FOLLOWING CONDITIONS

1. All packages, cartons or other containers must be plainly marked with the purchase order number.
2. The right is reserved to purchase in the open market and to charge the difference to the Vendor in the event that deliveries are not made at the time specified in the bid and on this order.
3. Whenever a delivery is rejected, the Vendor shall be notified and be given the reason for the rejection. All rejected deliveries shall be held at the Vendor's risk and he shall bear the expense of removal.
4. Acceptance of this order includes acceptance of all terms, prices, delivery, instructions, specifications and conditions stated.
5. The county is not liable for Federal excise tax or state sales tax.
6. Each shipment and/or each purchase order should be covered by separate invoice.

IMPORTANT: INVOICES AND PACKAGES MUST BEAR PURCHASE ORDER NUMBER

VENDOR'S COPY

There is an otherwise unincumbered balance to the credit of the proper appropriation, allotment or fund to meet the expenditure covered by this purchase.

Authorized Signature

APPROVED:

Purchasing Agent

Gray

PAXTON / PATTERSON

4141 W. 126th Street | Alsip, IL 60803 | 877-243-8763

Quote Date: 3/10/2025

Dear Gray Elementary School,

This letter states for the record, that **we are the sole providers** of all Paxton/Patterson Learning Systems, including College & Career Ready Labs, Career Discovery Labs, Health Science Careers, and Construction Career Labs.

Paxton/Patterson developed these learning systems with the written curriculum, interactive multimedia, and proprietary Learning Management System, along with the necessary components to bring to your school a complete program for College & Career Readiness. Our programs are fully and exclusively supported by our educational consultants, professional development team, implementation specialists, and customer service teams. All curriculum is copyrighted and the exclusive properties of Paxton/Patterson LLC.

Best Regards,

Christy Rogers

7083257125

christy@paxpat.com

PAXTON / PATTERSON

4141 W. 126th Street | Alsip, IL 60803 | 877-243-8763

Gray Elementary School
755 Gray Station Rd
Gray TN 37615-3120

Quote ID: QUO-03566-Y6P2F2
Quote Date: 3/10/2025

Total: \$22,875.00

Tax: \$0.00

Total Amount: \$22,875.00

Quote Valid for 90 Days

PLEASE Email Purchase Orders to sales@paxpat.com and copy christy@paxpat.com

Product	Stock Number	Price Per Unit	Quantity	Total
Intro to Health Science Careers	860550	\$4,295.00	1	\$4,295.00
Mental Health	860018	\$2,395.00	1	\$2,395.00
Therapeutic Services	860030	\$4,695.00	1	\$4,695.00
HVAC	780307	\$4,995.00	1	\$4,995.00
Video Production (iPad Required)	723576	\$4,495.00	1	\$4,495.00
Setup & Assembly - Lab (1-9)	643440	\$2,000.00	1	\$2,000.00

Created On: 3/10/2025 3:58 PM

WARRANTY

Thank you for purchasing a Paxton/Patterson learning system. Your purchase includes warranty protection from defects in materials and workmanship when the learning system is used under appropriate educational conditions.

Key aspects of the warranty are:

- Your warranty period starts when your lab is installed and ends one year later.
- Equipment which does not perform properly will be repaired or replaced with a new or remanufactured product. The replacement or repaired equipment remains under warranty for the balance of the original warranty period.
- If there are any integrated instructional unit guidebook pages which we modify due to an inaccuracy preventing student learning, those pages will immediately be reprinted and mailed to you.
- Please contact our learning systems technical support staff at 800.631.0158 for equipment matters.

Technical Support:

- Your lab instructor will participate in our four step professional development program, Register, Complete Online Lessons, 4 hour On-Site Support Session and Attend Regional Workshop(optional).
- Should your instructor have questions about the learning system after completing professional development, our technical support staff is available Monday – Friday 7:00am to 5:00pm central time. If needed our staff can also be available by appointment at other times to provide technical support to your instructor. Except in unusual situations, technical support can be quickly and conveniently accessed via telephone, email and use of our “desktop streaming” support technology.
- We have consistently found that when an additional instructor is assigned to a lab or a new instructor is hired to replace the instructor who had completed professional development, the new instructor definitely needs to complete professional development just as your first instructor did. New instructors need considerably more formal training to effectively use the learning system lab than our tech support staff can provide via telephone.

**Exclusions to this warranty include: (a) consumable materials like paints and finishes, batteries, sanding materials and worksheets, (b) failure caused by misuse or accidents, (c) theft or “mysterious” disappearance, (d) normal wear and tear on guidebooks, textbooks, videos and other printed materials, and (e) damaged or lost computer software – CDs and diskettes. In conformity with your district’s copyright law compliance policy we recommend that back-up copies be made of all computer software (CDs) exclusively for use in the learning system covered by this warranty.*

PAXTON/PATTERSON (PP) LEARNING SYSTEMS CONTENT DELIVERY

PP will provide the Paxton Content Learning Management System for 60 months with a service start date to be set after installation by PP.

During the 60 months PP will:

- Provide access to Learning System content from modern browsers.
- Provide updates to Learning System content and to the Paxton Content Learning Management System.

During the 60 months it is likely that some 3rd party providers of equipment, software, and licensed assets included in your original purchase will upgrade their products. It is impossible to predict the scope of these potential future upgrades by 3rd party sources, therefore PP has not "built in" any costs for those items in the original purchase prices.

PP will advise you well in advance of the upgrade potentials being available, advising you of how the upgrade will enhance student learning and the costs of the upgraded equipment, software and/or licensed assets.

Most importantly, no purchase of upgraded equipment, software or licensed assets will be required at any time during the 60 months – because the PP learning system originally purchased will be supported during the entire 60 months.

The only time that it may be necessary to upgrade equipment, software or licensed assets is if your school chooses to upgrade to a newer operating system that is not compatible with the originally purchased 3rd party equipment, software, or licensed assets.

PURCHASING DEPARTMENT
WASHINGTON COUNTY BOARD OF EDUCATION

PURCHASE ORDER

Purchase Order **No 4898**

Date Issued **3/20/25**

Appropriation No. **141-E-71300-730-002**

Dept. **ISM grant**

School **Sulphur Springs**

To **Snap-on Industrial**
3011 IL RTE 176, DOOR 1
Crystal Lake, IL 60014

NOTICE TO VENDOR

1. Purchase order **MUST** bear two signatures in order to be valid.
2. Purchase order number **MUST** appear on all invoices submitted for payment.
3. Mail **TWO** copies of your invoice promptly to:

Washington County Board of Education
405 West College Street
Jonesborough, TN 37659
Telephone (423) 753-1105

Deliver to **Sulphur Springs Elementary**
1518 Gray Station Sulphur Springs Rd.
Jonesborough, TN 37659
 Address
 Via **Diana O'Neal**

Articles on this order must be charged to account of

ARTICLES OR SERVICES	CODE	QUANTITY & UNIT	UNIT PRICE	TOTAL
(Unless otherwise stated all prices F.O.B. Destination)				
Tool ID & safety cert. kit				\$13,193.⁰⁹
consumables kit				\$ 65.31
sole source attached				
GRAND TOTAL - INCLUDING ALL ATTACHED PAGES				\$13,258.⁴⁰

SUBJECT TO THE FOLLOWING CONDITIONS

1. All packages, cartons or other containers must be plainly marked with the purchase order number.
2. The right is reserved to purchase in the open market and to charge the difference to the Vendor in the event that deliveries are not made at the time specified in the bid and on this order.
3. Whenever a delivery is rejected, the Vendor shall be notified and be given the reason for the rejection. All rejected deliveries shall be held at the Vendor's risk and he shall bear the expense of removal.
4. Acceptance of this order includes acceptance of all terms, prices, delivery, instructions, specifications and conditions stated.
5. The county is not liable for Federal excise tax or state sales tax.
6. Each shipment and/or each purchase order should be covered by separate invoice.

IMPORTANT: INVOICES AND PACKAGES MUST BEAR PURCHASE ORDER NUMBER

VENDOR'S COPY

There is an otherwise unincumbered balance to the credit of the proper appropriation, allotment or fund to meet the expenditure covered by this purchase.

Authorized Signature

APPROVED:

Purchasing Agent



3/19/2025

Re: Sole Source Letter

To Whom It May Concern:

Thank you for your interest in Snap-on Industrial.

This is to inform you that the following Certification/Tool Sets, per quote # IMP-001443197, were designed and developed by Snap-on, and are exclusively distributed by Snap-on:

SNAP-ON CERTIFICATION SETS

Part Number	Description
HTISCERTKIT	TOOL ID & SAFETY CERT KIT
HTISCONSUM	CONSUMABLES KIT HTISCERTKIT

Best Regards

A handwritten signature in black ink, appearing to read "D. Campbell". The signature is written in a cursive, somewhat stylized font.

David Campbell
Account Manager – Snap-on Industrial



Quote

Submit to Snap-on Industrial
 3011 IL RTE 176, Door 1
 Crystal Lake, IL 60014
 877-740-1900

Quote Number IMP-001443197
Quote Date 3/18/2025
Quote Expiration Date 5/17/2025
Customer Name WASHINGTON COUNTY SCHOOLS
Customer BP 201605275
Contact Information:
Name Diana O'Neal
E-mail oneald@wcde.org
Phone Number 423-753-1140
Sales Rep CAMPBELL, DAVID M
Mobile # 423-579-0820
E-mail Address David.Campbell2@snapon.com

Ship Via 1 - UPS GROUND
Payment Terms P30 - NET 30 DAYS
Ship to 201605275
 SULPHUR SPRINGS ELEMENTARY
 1518 GRAY STATION SULPHUR
 SPRINGS ROAD
 JONESBORO TN 37659
Bill to 201508788
 WASHINGTON COUNTY SCHOOLS
 405 W COLLEGE ST
 JONESBORO TN 37659

Line Number	Part Number	Description	Quantity	List Price	Unit Net Price	Line Total
1	HTISCERTKIT	TOOL ID & SAFETY CERT KIT	1	\$21,930.00	\$13,193.09	\$13,193.09
2	HTISCONSUM	CONSUMABLES KIT HTISCERTKIT	1	\$119.00	\$65.31	\$65.31

Total Weight 475.28 lbs
Sub Total \$13,258.40
Shipping \$0.00
Tax \$0.00

Grand Total \$13,258.40

Tax and freight shown are estimates.

Applicable tax and freight will be charged to the Customer's account.

The sale of product is subject to Snap-on Industrial's standard terms and conditions of sale. Placement of an order is Customer's assent to these terms and conditions and Snap-on hereby objects to any additional and/or different terms, which may be contained in any Customer forms or other documents. No such additional terms will be of any force or effect.

The sale of product is subject to Customer meeting Snap-on Industrial's credit approvals. Financing through Snap-on Credit LLC is available on most purchases. Ask your Sales Rep for more information.

*Please provide vendor and pricing information to customer service on this part number.

Washington County Board of Education

Monitoring: Review: Annually	Descriptor Term: <h2 style="text-align: center;">Community Use of Facilities</h2>	Descriptor Code: 3.208	Issued Date: 09/05/19
		Rescinds: 3.208	Issued: 07/11/19

1 When not in use for school purposes, school buildings and grounds or portions thereof may be used at
 2 no charge for public, governmental, charitable, civic, recreational, cultural or other purposes as
 3 approved b y the Board.^{1,2,3,4,5}

- 4 1. Requests for use of the facilities shall be made at the office of the principal prior to the date of
 5 use;
- 6 2. Student clubs and activities, parent-teacher associations, school booster clubs, and school
 7 alumni organizations shall be permitted to use the school facilities without charge;
- 8 3. The facility use fee may be waived for organizations planning an activity in which the majority
 9 of participants in their planned activity are school-aged children enrolled in Washington
 10 County Schools;
- 11 4. School facilities may not be used for private profit, provided, however, unused facilities may be
 12 leased for private day-care centers and kindergartens, which provide educational and childcare
 13 services to the community;² and further provided that athletic fields and facilities may be leased
 14 to day camps, sports camps, and similar ventures that provide recreational and athletic
 15 opportunities to the community; and still further provided that any such group leasing any
 16 school facility shall carry sufficient insurance to protect, defend, and indemnify the Board
 17 against any injuries to any person sustained while using the Board’s property.
- 18 5. All activities must be under adult supervision and approved by the building principal and the
 19 Central Office Purchasing Agent. The requesting group or organization must make
 20 arrangements through the building principal for an approved WCDE employee to be present
 21 during all activities. The WCDE employee may be a full or part time employee or non-faculty
 22 coach. The Athletic Directors may sign rental contracts for events involving athletic facilities
 23 instead of the principal. The group using the facilities will be responsible for any damage to the
 24 building or equipment.
- 25 6. Groups receiving permission for building use are restricted to the dates and hours approved and
 26 to the building area and facilities specified, unless requested changes are approved by the
 27 principal;
- 28 7. Groups receiving permission for building use are responsible for the observance of all fire and
 29 safety regulations at all times;
- 30 8. The use of alcoholic beverages, drugs, profane language, or gambling in any form is not
 31 permitted on school property;
- 32 9. The Board will cooperate with recognized agencies, such as the Red Cross, National Guard and
 33 Civil Defense, and will make suitable facilities available without charge during community
 34 emergencies;
- 35 10. When school kitchens are used, at least one member of the cafeteria staff must be present to
 36 supervise the use of equipment;
- 37 11. School facilities shall not be used for religious purposes on an extended or permanent basis;

- 1 12. Should a religious organization request to use school facilities for an activity other than
2 instructional and/or religious nature, the organization will be treated as any other community
3 organization;
- 4 13. The Board will approve and periodically review a fee schedule for the use of school facilities
5 by community or civic organizations and other non-profit, recreational, religious, political or
6 philosophical groups. The Administration has the authority, on case-by-case basis, to condition
7 the use of the Board's property on sufficient insurance to protect, defend, and indemnify the
8 Board against any injuries occurring while the property is being used.
- 9 14. Building principals have the discretion of waiving cleaning fees when it is determined that the
10 planned activity will not necessitate cleaning services.
- 11 15. Rental fees may be waived for athletic events sanctioned by TSSAA or TMSAA.
12

Legal References

1. TCA 49-2-203(a)(2)
2. TCA 49-2-203(b)(4)
3. Lambs Chapel v. Center Moriches Union Free School District, 113 S. Ct., 2141 (1993)
4. Sherman v. Community Consolidated School District 21 of Wheeling Township, 1993 W.L. 57522 (N.D. Ill. 1993)
5. Equal Access Act, 20 U.S.C. 4071, Title 20, Chapter 42, Subchapter VIII